

SHORT STROKE

Cylinders



Find out our
key products



Solution for most applications



Easy and intuitive choice



Excellent value for money



Wide availability



Fast delivery



Short Stroke Cylinders

1 - CYLINDERS

Features and certifications

Series of short stroke cylinders, available in bores from Ø 12 to 100, single acting or double acting, magnetic or non magnetic, with female thread. Up to bore Ø 100 with extruded aluminium profile barrell allowing the direct mounting of magnetic reed switches, and built-in mounting holes. Supplied as standard in compliance with Reach and RoHS directives, and SIL certificated. On request, they can be also supplied according to the 2014/34/EU ATEX Directive.



Type BS Ø 12 ÷ 100

from page 1.20.20



Short stroke cylinders, available in bores from Ø 12 to 100, single acting, non magnetic, with female thread. Mounting holes are built-in the barrel.

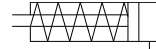

Type BSM Ø 12 ÷ 100

from page 1.20.20



Short stroke cylinders, available in bores from Ø 12 to 100, single acting, magnetic, with female thread and elastic dampers on the heads. Barrell present built-in mounting holes and grooves allowing the mounting of magnetic reed switches (with bracket to be ordered separately).



Type BD Ø 12 ÷ 100

from page 1.20.40



Short stroke cylinders, available in bores from Ø 12 to 100, double acting, non magnetic, with female thread. Mounting holes are built-in the barrel.

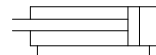

Type BDM Ø 12 ÷ 100

from page 1.20.40



Short stroke cylinders, available in bores from Ø 12 to 100, double acting, magnetic, with female thread and elastic dampers on the heads. Barrell present built-in mounting holes and grooves allowing the mounting of magnetic reed switches (with bracket to be ordered separately).

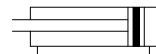

Short Stroke Cylinders

1 - CYLINDERS

Options matching

Series	Bore	Model	Standard options matching					
			N (Ø20÷100)	T (Ø12÷63)	P (Ø16÷100)	V (Ø16÷100)	SGX (Ø25÷100)	IATEX
BS-BSM	Ø 12 ÷ 100	Standard	-	●	-	●	●	●
	Ø 12 ÷ 63	Rear spring (T)	-		-	●	●	●
BD	Ø 12 ÷ 100	Standard	●	-	●	●	●	●
	Ø 16 ÷ 100	Through rod (P)	●	-		●	●	●
BDM	Ø 12 ÷ 100	Standard	●	-	●	●	●	●
	Ø 20 ÷ 100	Anti-rotating plate (N)		-	●	●	●	●
	Ø 16 ÷ 100	Through rod (P)	●	-		●	●	●

Key

● allowed matching; - not allowed matching

Standard materials

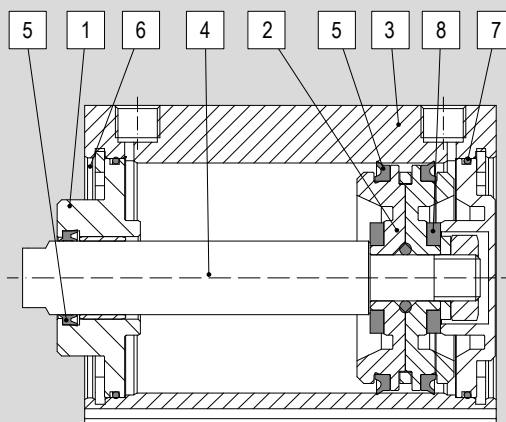

Position	Description	Materials									
		Ø 12	Ø 16	Ø 20	Ø 25	Ø 32	Ø 40	Ø 50	Ø 63	Ø 80	Ø 100
1	End cover	Brass					Aluminium				
2	Semi-piston	Magnetic	Acetalic resin (POM)							Aluminium	
		Non magnetic	Acetalic resin (POM)					Aluminium			
3	Tube	Anodised aluminium									
4	Rod	Stainless Steel AISI 303									
5	Rod seal	Polyurethane (PU)									
6	Seeger	Steel									
7	Seals	NBR									
8	Elastic dampers	NBR									

Short Stroke Cylinders

1 - CYLINDERS

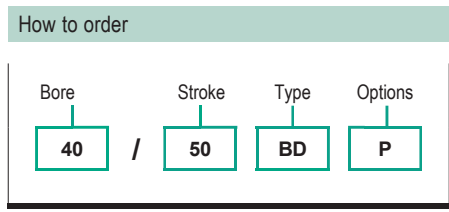
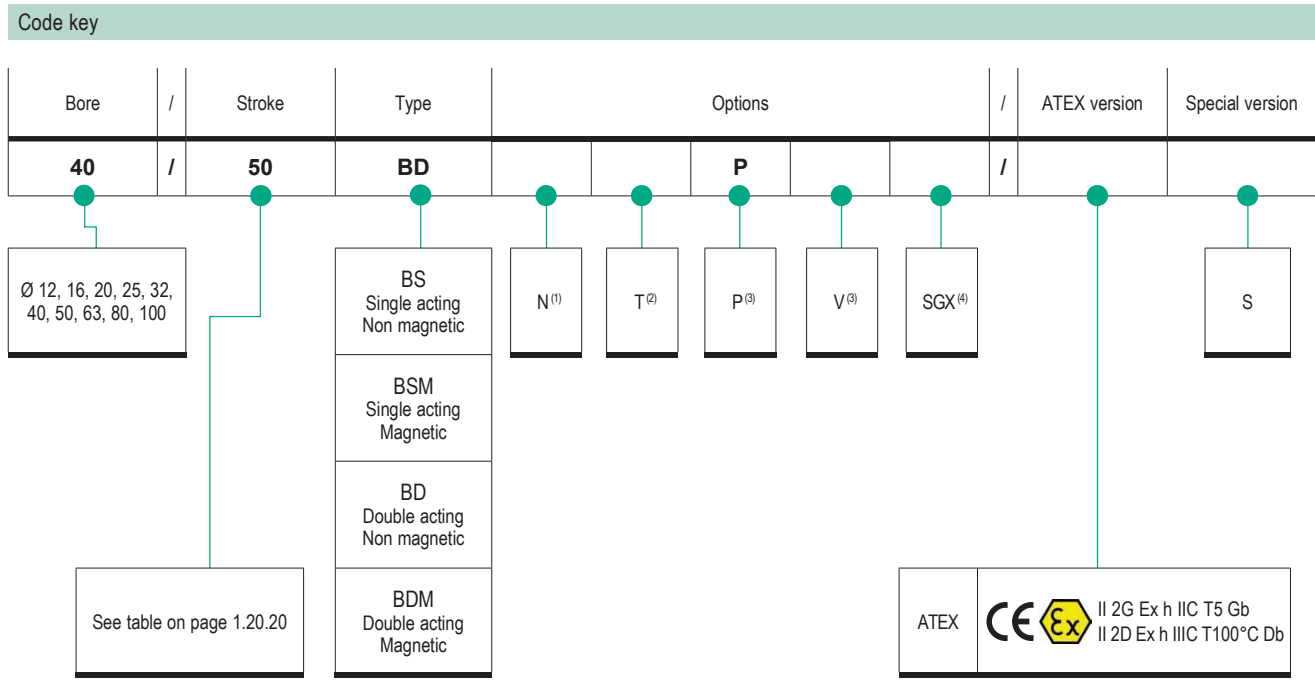

Notes

Options in the same grid are alternative to each others.
 For further information on options and their matching, see page 1.20.3 and page 1.20.4

(1) Available only for types BD and BDM from Ø 25 to 100
 (2) Available only for types BS and BSM from Ø 12 to 63
 (3) Available from Ø 16 to 100
 (4) Available from Ø 25 to 100

For further information on the ATEX 2014/34/EU Directive, on classifications and protections, see from page III.1

Seal kit standard*

Number of components	Description
n. 1	Rod seal
n. 2	Barrell o-ring
n. 1	Semipiston o-ring
n. 2	Piston seal
n. 2	Elastic dampers

*For cylinders with options P or V, the kit include further components.

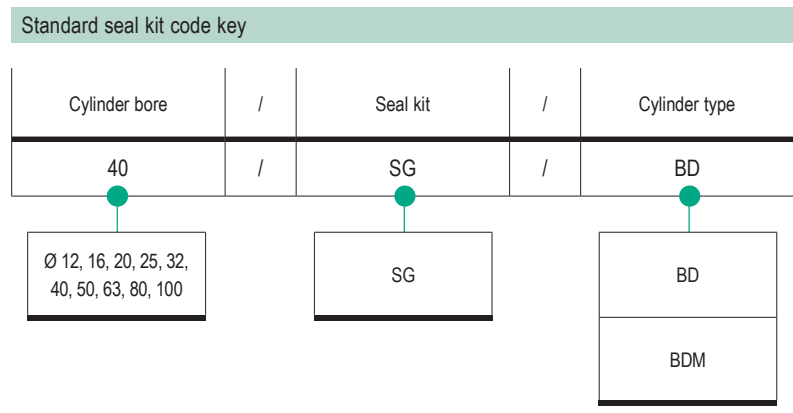

Accessories

1 - CYLINDERS

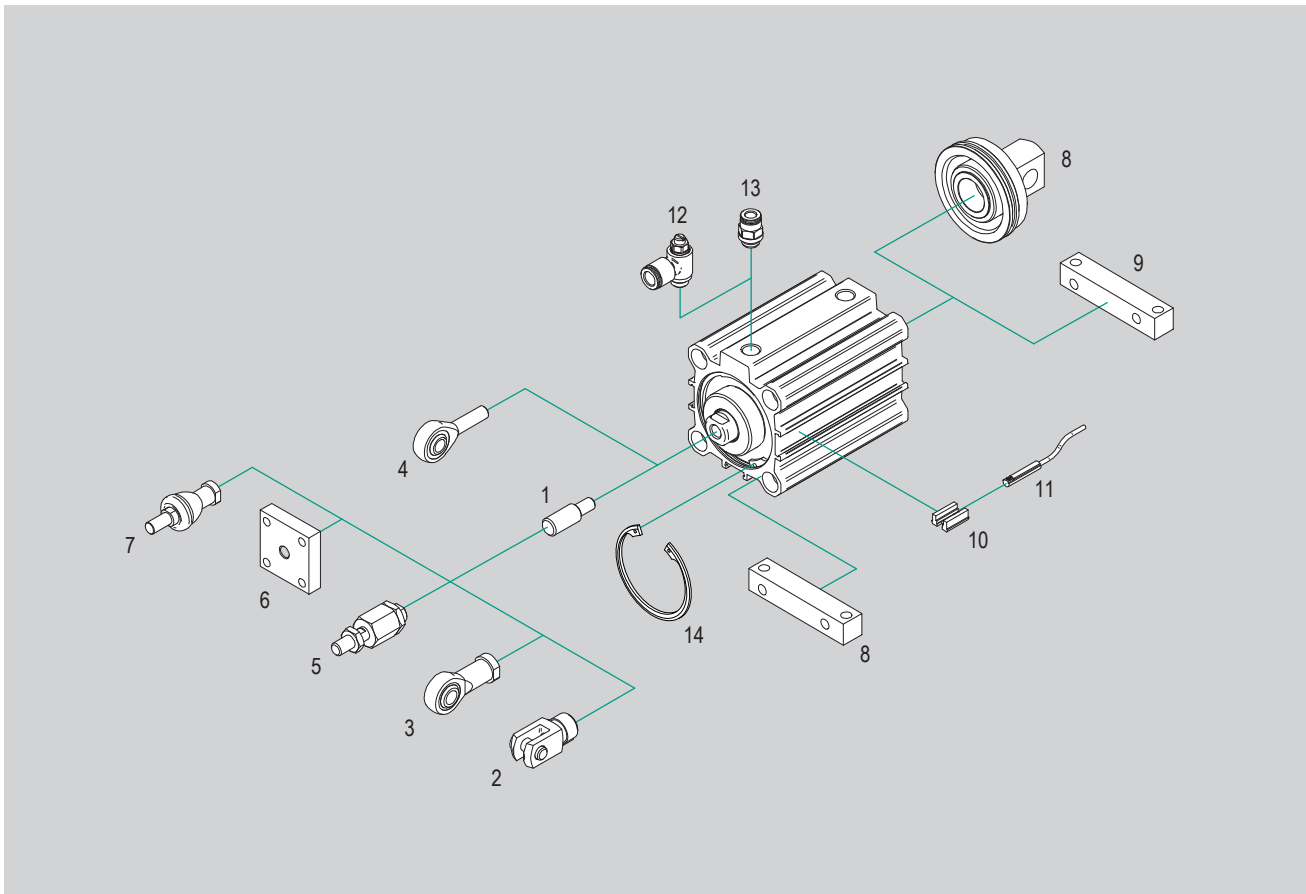

N.	Cylinder bore	Item	Description	Compliance	Matching		Code page	Data sheet page	
					BS-BD	BSM-BDM			
1	Ø 12 ÷ 100	N..AQB	Rod nipple	-	●	●	1.20.90	1.90.60	
2	Ø 12 ÷ 100	FF..ISO	ISO female clevis with clip	ISO 8140	● ⁽¹⁾	● ⁽¹⁾		1.85.10	
	Ø 32 ÷ 100	FFN..ISO	ISO female clevis with pin and seeger		● ⁽¹⁾	● ⁽¹⁾		1.85.11	
	Ø 12 ÷ 100	FFN..ISO	ISO female clevis (body only)		● ⁽¹⁾	● ⁽¹⁾		1.90.1	
3	Ø 12 ÷ 100	RF..SE	Bearing head (DIN 648K) with female thread	ISO 8139	● ⁽¹⁾	● ⁽¹⁾		1.90.2	
4	Ø 16 ÷ 63	RM..SE	Bearing head (DIN 648K) with male thread	ISO 8139	●	●		1.20.91	1.90.10
	Ø 80 ÷ 100			DIN	●	●			
5	Ø 12 ÷ 100	GB..	Bearing - Self-aligning articulated coupling	-	● ⁽¹⁾	● ⁽¹⁾		1.90.40	
6	Ø 32 ÷ 100	GC..	Self-aligning coupling		● ⁽¹⁾	● ⁽¹⁾		1.90.20	
7	Ø 12 ÷ 100	RBI..	Bearing - Axial articulated coupling		● ⁽¹⁾	● ⁽¹⁾		1.90.30	
		RBL..	Bearing - Angular articulated coupling		● ⁽¹⁾	● ⁽¹⁾		1.100.201	
8	Ø 16 ÷ 100	CM..ALB	Back head with integrated rear eye		● ⁽²⁾	● ⁽²⁾		1.100.200	
9	Ø 16 ÷ 100	P..ALB	High foot		●	●		1.120.2	
10	Ø 12 ÷ 100	AS108	Bracket for reed switches type "T"		-	●		1.110.10	
11	Ø 12 ÷ 100	ASV..	Magnetic reed switch T groove	-	●	1.113.1			
		MK..	ATEX magnetic reed switch T groove	2014/34/EU	-	●			
12	Ø 12 ÷ 100	R..	Push-in fittings	-	●	●	4.2.1		
13	Ø 12 ÷ 100	V..C	Flow controls, for cylinders	-	●	●	4.94.1		
14	Ø 25 ÷ 100	SGX..	Stainless steel seeger for front head	-	●	●	1.20.91	-	

Key

● matching accessory; - not matching accessory

(1) Matching only with rod nipple N..AQB mounted
(2) Accessory to be ordered with the cylinder

Short Stroke Cylinders

Series BS - BSM

1 - CYLINDERS

Main features

12 ÷ 100

Bores Ø

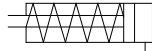

Single acting
Non magnetic
With female thread

BS

Type



12 ÷ 100

Bores Ø

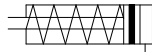

Single acting
Magnetic
With female thread

BSM

Type



Technical data

Bore Ø mm	12	16	20	25	32	40	50	63	80	100
Fluid	Filtered compressed air with or without lubrication. Lubrication, if started, must be continued.									
Pressure range	2 ÷ 10 bar									
Temperature range	-20°C ÷ +80°C (standard)					-20°C ÷ +150°C (V)				
Port	M5					1/8"			1/4"	
Thrust force (N)	51	106	170	258	441	729	1070	1720	2880	4400
Spring traction force (N)	5	6		13	18	20	40	49	76	131
Strokes*	5 ÷ 25 mm					5 ÷ 50 mm				
Rod thread	M3	M4	M5		M6	M8		M10	M12	

*In case of intermediate strokes from the standard strokes (see table below), the cylinder body will have the overall dimensions of the cylinder with the next standard stroke, as desired stroke is obtained by applying a spacer.

Standard strokes

Stroke mm	BS Bore Ø mm									
	12	16	20	25	32	40	50	63	80	100
5										
10										
15										
20										
25										
30										
40										
50										

Stroke mm	BSM Bore Ø mm									
	12	16	20	25	32	40	50	63	80	100
5										
10										
15										
20										
25										
30										
40										
50										

Key
 Standard stroke

Short Stroke Cylinders
Series BS - BSM

1 - CYLINDERS

Standard dimensions

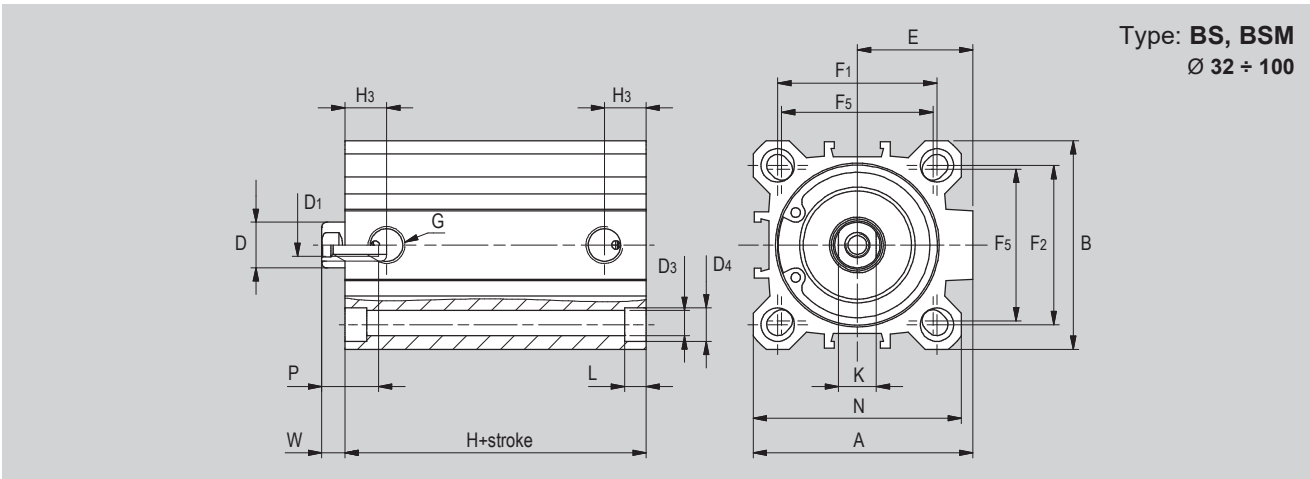
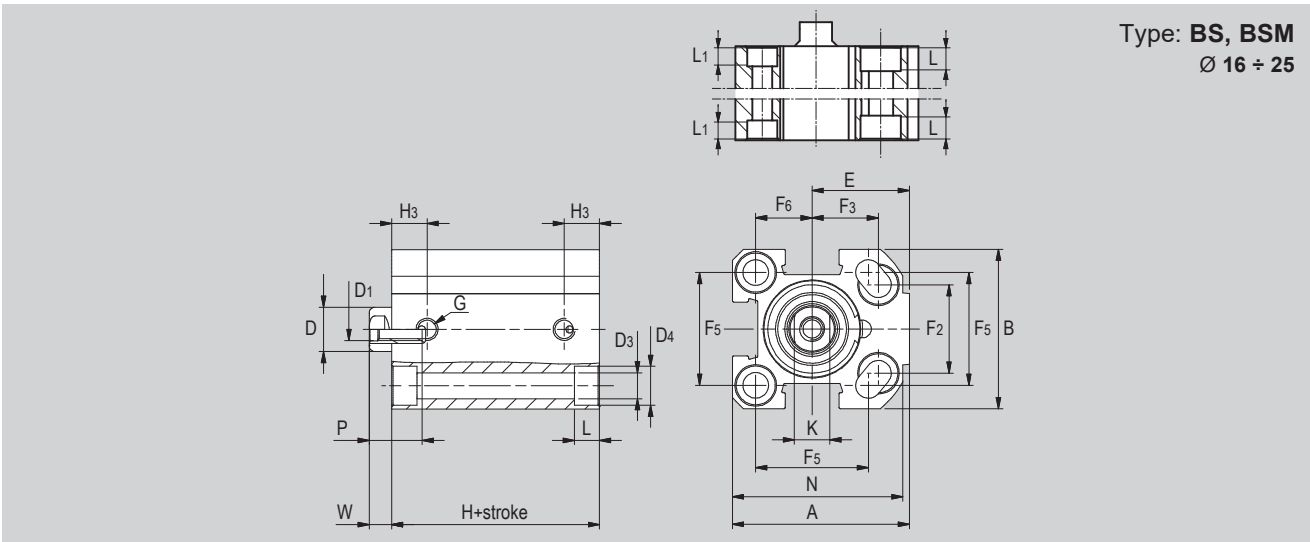
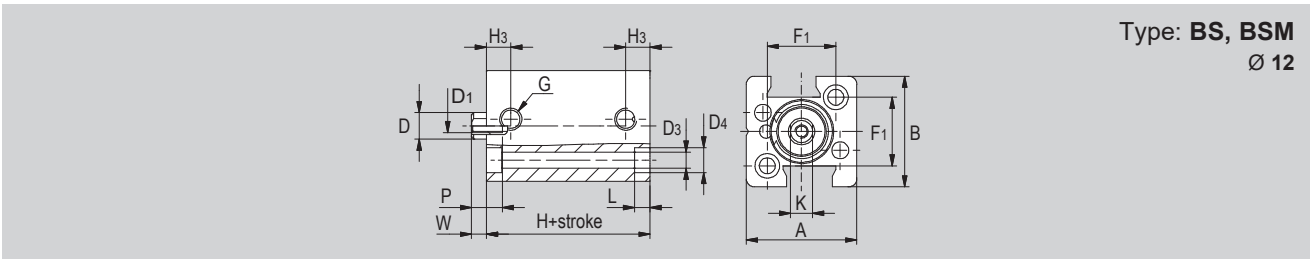

Ø (mm)	A	B	ØD	D ₁	ØD ₃	ØD ₄	E	G	H		H ₃	F ₁	F ₂	F ₃	F ₅	F ₆	K	L	L ₁	N	P	W
									type BS	type BSM												
12	25	25	6	M3	3,7	5,6	-	M5	17 ⁽¹⁾	27	5,5	15,5	-	-	-	-	5	3,5	-	-	7	3,5
16	34	30	8	M4	4,7	7,5	19	M5	27	32 ⁽³⁾	8	-	18	12	20	10	6	4,6	3,5	32	11	4,5
20	40	36	10	M5	5,8	9	22	M5	27	32 ⁽³⁾	8	-	20	15	25,5	12,7	8	5,7	5,7	38,5	12	5
25	44,5	40	10	M5	5,8	9	24,5	1/8"	28,5	38,5 ⁽⁴⁾	10,5 ⁽⁶⁾	-	26	15,5	28	14	8	5,7	5,7	42	12	5,5
32	51	46	12	M6	5,8	9	27	1/8"	29,5 ⁽²⁾	39,5 ⁽⁵⁾	11,5 ⁽⁷⁾	36	32	-	34	-	10	5,7	-	48	15	6
40	58	55	12	M6	5,8	9	30,5	1/8"	29,5 ⁽²⁾	39,5 ⁽⁵⁾	11 ⁽⁷⁾	42	42	-	40	-	10	5,7	-	55	15	6
50	70	65	16	M8	6,8	11	37,5	1/8"	34,5 ⁽²⁾	39,5 ⁽⁵⁾	11,5	50	50	-	50	-	13	6,8	-	65	17	7,5
63	89	80	16	M8	9	14	46	1/8"	37 ⁽²⁾	42 ⁽³⁾	11	62	62	-	60	-	13	8,8	-	80	17	7
80	105	100	20	M10	9	14	55	1/4"	46 ⁽²⁾	46 ⁽³⁾	14	82	82	-	77	-	17	9	-	100	17	8
100	131	124	25	M12	11	17,2	69	1/4"	56 ⁽²⁾	56 ⁽³⁾	16	103	103	-	94	-	22	11	-	124	22	10

(1) For strokes 15, 20 and 25 mm, add +5 mm to dimension; (2) For strokes 40 and 50 mm, add +10 mm to dimension; (3) For stroke 25 mm, add +6 mm to dimension; (4) For strokes 25 mm, add +1 mm to dimension; (5) For strokes 40 and 50 mm, add +10 mm to dimension; (6) If quote H is less than 38,5 the dimension is 8,5; (7) If quote H is less than 39,5 the dimension is 8.

Dimensions with options

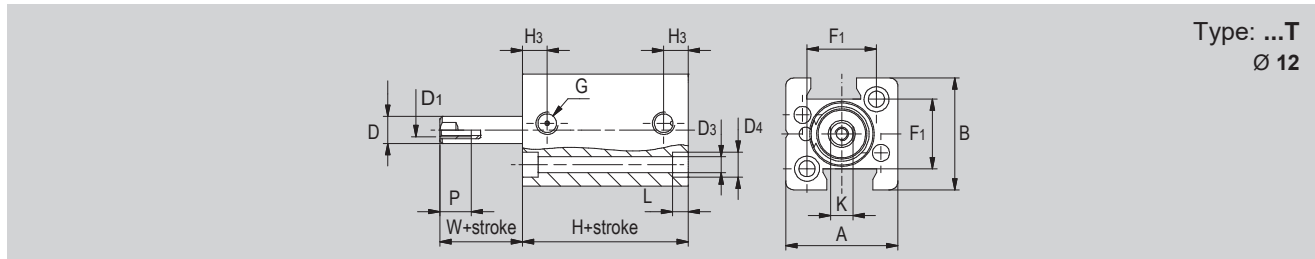

Type: ...T
Ø 12

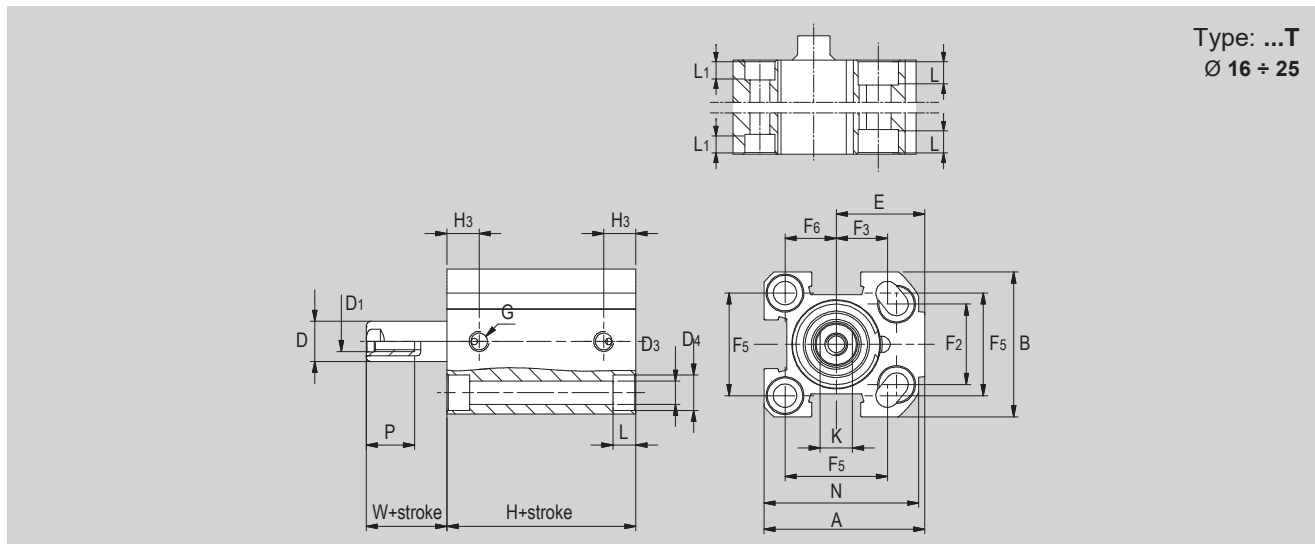

Type: ...T
Ø 16 ÷ 25

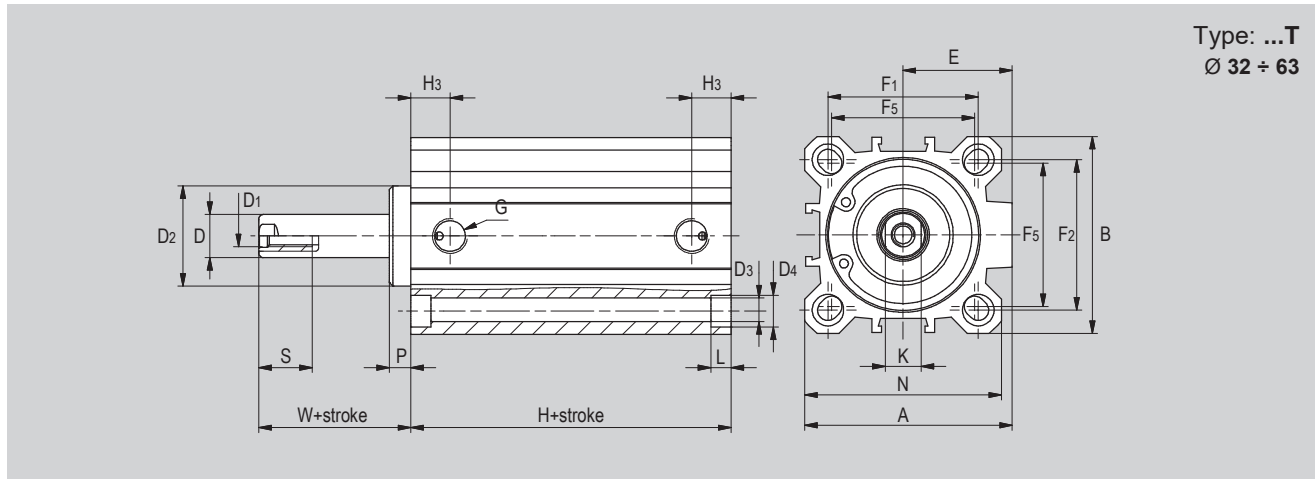

Type: ...T
Ø 32 ÷ 63

Ø (mm)	A	B	ØD	D ₁	ØD ₂	ØD ₃	ØD ₄	E	G	H	H ₃	F ₁	F ₂	F ₃	F ₅	F ₆	K	L	L ₁	N	P	S	W
12	25	25	6	M3	-	3,7	5,6	-	M5	17 ⁽¹⁾	5,5	15,5	-	-	-	-	5	3,5	-	-	7	-	3,5
16	34	30	8	M4	-	4,7	7,5	19	M5	32 ⁽²⁾	8	-	18	12	20	10	6	4,6	3,5	32	11	-	4,5
20	40	36	10	M5	-	5,8	9	22	M5	32 ⁽²⁾	8	-	20	15	25,5	12,7	8	5,7	5,7	38,5	12	-	4,5
25	44,5	40	10	M5	-	5,8	9	24,5	1/8"	38,5 ⁽³⁾	10,5	-	26	15,5	28	14	8	5,7	5,7	42	12	-	5,5
32	51	46	12	M6	24,5	5,8	9	27	1/8"	39,5 ⁽⁴⁾	11,5	36	32	-	34	-	10	5,7	-	48	15	5	11
40	58	55	12	M6	28	5,8	9	30,5	1/8"	39,5	11	42	42	-	40	-	10	5,7	-	55	15	6	12,5
50	70	65	16	M8	34	6,8	11	37,5	1/8"	39,5	11,5	50	50	-	50	-	13	6,8	-	65	17	6	13,5
63	89	80	16	M8	38,5	9	14	46	1/8"	42	11	62	62	-	60	-	13	8,8	-	80	17	8	15

(1) For BS type the dimension is 17, for BSM type the dimension is 27; (2) For strokes 20 and 25 mm, add +11 mm to dimension; (3) For strokes 20 and 25 mm, add +6 mm to dimension; (4) For strokes 20 and 25 mm, add +5 mm to dimension, while for stroke 30 mm add +10 mm to dimension.

Short Stroke Cylinders

Series BD - BDM

1 - CYLINDERS

Main features

12 ÷ 100

Bores Ø

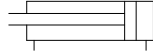

Double acting
Non magnetic
With female thread



BD

Type



12 ÷ 100

Bores Ø

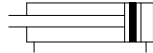

Double acting
Magnetic
With female thread



BDM

Type



Technical data

Bore Ø mm	12	16	20	25	32	40	50	63	80	100		
Fluid	Filtered compressed air with or without lubrication. Lubrication, if started, must be continued.											
Pressure range	2 ÷ 10 bar											
Temperature range	-20°C ÷ +80°C (standard)					-20°C ÷ +150°C (V)						
Port	M5					1/8"			1/4"			
Strokes*	BD	5 ÷ 40 mm		5 ÷ 50 mm			5 ÷ 100 mm		10 ÷ 100 mm			
	BDM	5 ÷ 40 mm		5 ÷ 100 mm		5 ÷ 125 mm		5 ÷ 160 mm		10 ÷ 200 mm		10 ÷ 250 mm
	..N	-		5 ÷ 125 mm			10 ÷ 125 mm		10 ÷ 160 mm			
Rod thread	M3	M4	M5	M6	M8	M10	M12					

*In case of intermediate strokes from the standard strokes (see table below), the cylinder body will have the overall dimensions of the cylinder with the next standard stroke, as desired stroke is obtained by applying a spacer.

Standard strokes

Stroke mm	BD Bore Ø mm									
	12	16	20	25	32	40	50	63	80	100
5	✓	✓	✓	✓	✓	✓				
10	✓	✓	✓	✓	✓	✓	✓			
15	✓	✓	✓	✓	✓	✓	✓	✓		
20	✓	✓	✓	✓	✓	✓	✓	✓	✓	
25	✓	✓	✓	✓	✓	✓	✓	✓	✓	
30	✓	✓	✓	✓	✓	✓	✓	✓	✓	
40	✓	✓	✓	✓	✓	✓	✓	✓	✓	
50			✓	✓	✓	✓	✓	✓	✓	
60										
80										
100										

Stroke mm	BDM Bore Ø mm									
	12	16	20	25	32	40	50	63	80	100
5	✓	✓	✓	✓	✓	✓				
10	✓	✓	✓	✓	✓	✓	✓			
15	✓	✓	✓	✓	✓	✓	✓	✓		
20	✓	✓	✓	✓	✓	✓	✓	✓	✓	
25	✓	✓	✓	✓	✓	✓	✓	✓	✓	
30	✓	✓	✓	✓	✓	✓	✓	✓	✓	
40	✓	✓	✓	✓	✓	✓	✓	✓	✓	
50			✓	✓	✓	✓	✓	✓	✓	
60										
80										
100										
125										
160										
200										
250										

Stroke mm	..N Bore Ø mm							
	20	25	32	40	50	63	80	100
5								
10								
15								
20								
25								
30								
40								
50								
60								
80								
100								
125								
160								

Key
 Standard stroke

Standard dimensions

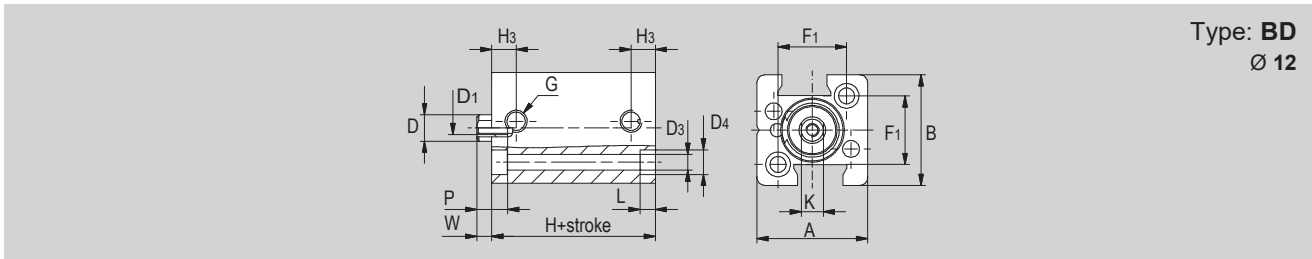

Type: **BD**
Ø 12

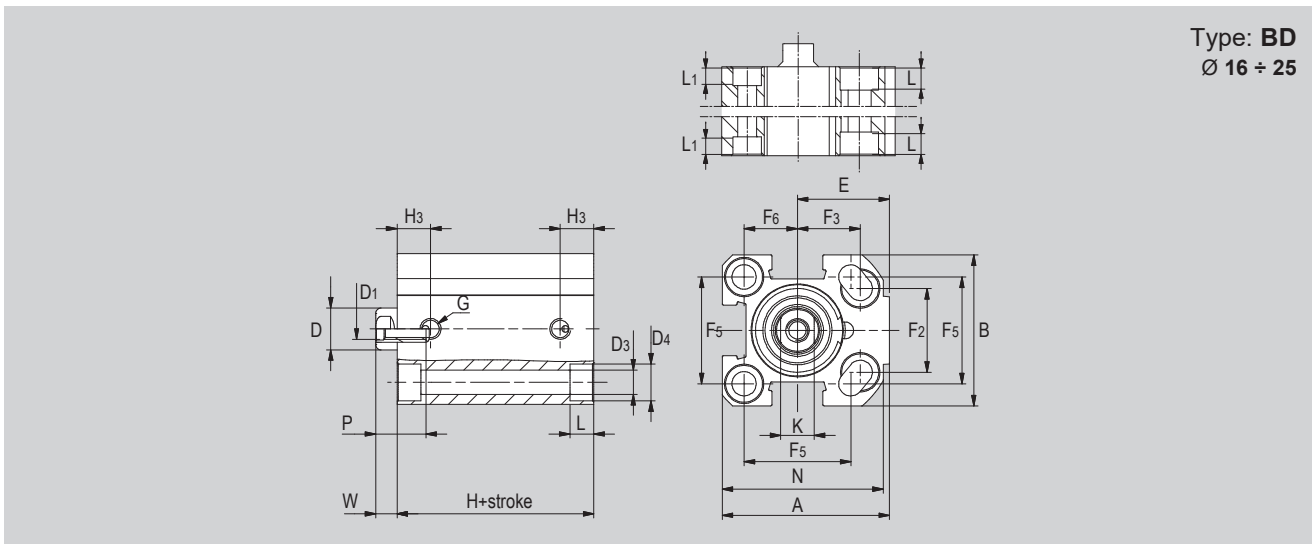

Type: **BD**
Ø 16 ÷ 25

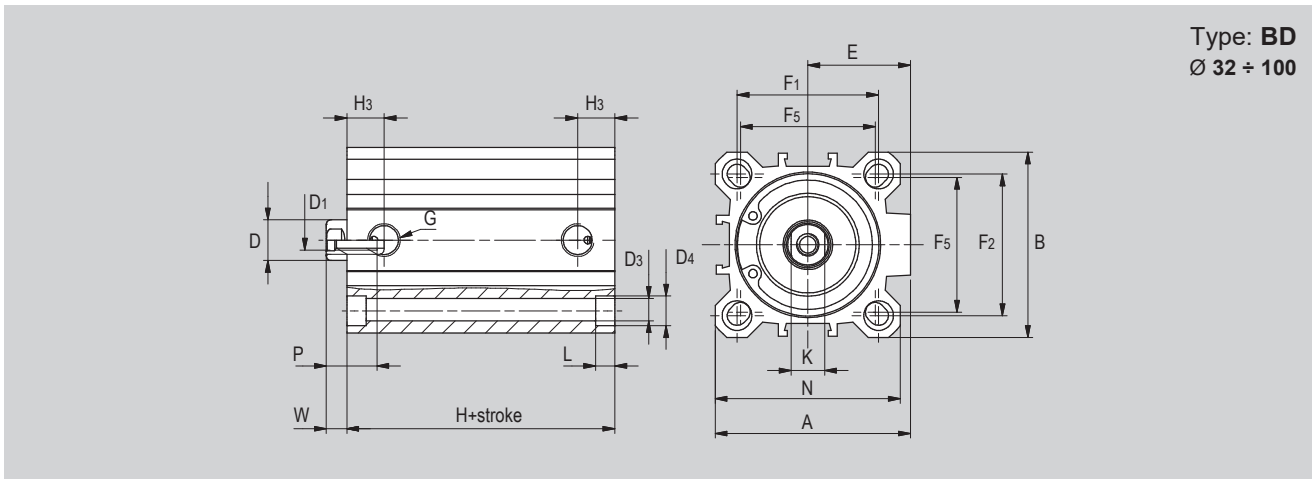

Type: **BD**
Ø 32 ÷ 100

Ø (mm)	A	B	ØD	D ₁	ØD ₃	ØD ₄	E	G	H	H ₃	F ₁	F ₂	F ₃	F ₅	F ₆	K	L	L ₁	N	P	W
12	25	25	6	M3	3,7	5,6	-	M5	17	5,5	15,5	-	-	-	-	5	3,5	-	-	7	3,5
16	34	30	8	M4	4,7	7,5	19	M5	27 ⁽¹⁾	8	-	18	12	20	10	6	4,6	3,5	32	11	4,5
20	40	36	10	M5	5,8	9	22	M5	27 ⁽¹⁾	8	-	20	15	25,5	12,7	8	5,7	5,7	38,5	12	5
25	44,5	40	10	M5	5,8	9	24,5	1/8"	28,5 ⁽²⁾	10,5 ⁽³⁾	-	26	15,5	28	14	8	5,7	5,7	42	12	5,5
32	51	46	12	M6	5,8	9	27	1/8"	29,5	11,5 ⁽⁴⁾	36	32	-	34	-	10	5,7	-	48	15	6
40	58	55	12	M6	5,8	9	30,5	1/8"	29,5	11 ⁽⁴⁾	42	42	-	40	-	10	5,7	-	55	15	6
50	70	65	16	M8	6,8	11	37,5	1/8"	34,5	11,5	50	50	-	50	-	13	6,8	-	65	17	7,5
63	89	80	16	M8	9	14	46	1/8"	37	11	62	62	-	60	-	13	8,8	-	80	17	7
80	105	100	20	M10	9	14	55	1/4"	46	14	82	82	-	77	-	17	9	-	100	17	8
100	131	124	25	M12	11	17,2	69	1/4"	56	16	103	103	-	94	-	22	11	-	124	22	10

(1) For strokes 30, 40 and 50 mm, add +1 mm to dimension; (2) For strokes 40 and 50 mm, add +1 mm to dimension; (3) If quote H is less than 38,5 the dimension is 8,5; (4) If quote H is less than 39,5 the dimension is 8

Short Stroke Cylinders
Series BDM

1 - CYLINDERS

Standard dimensions

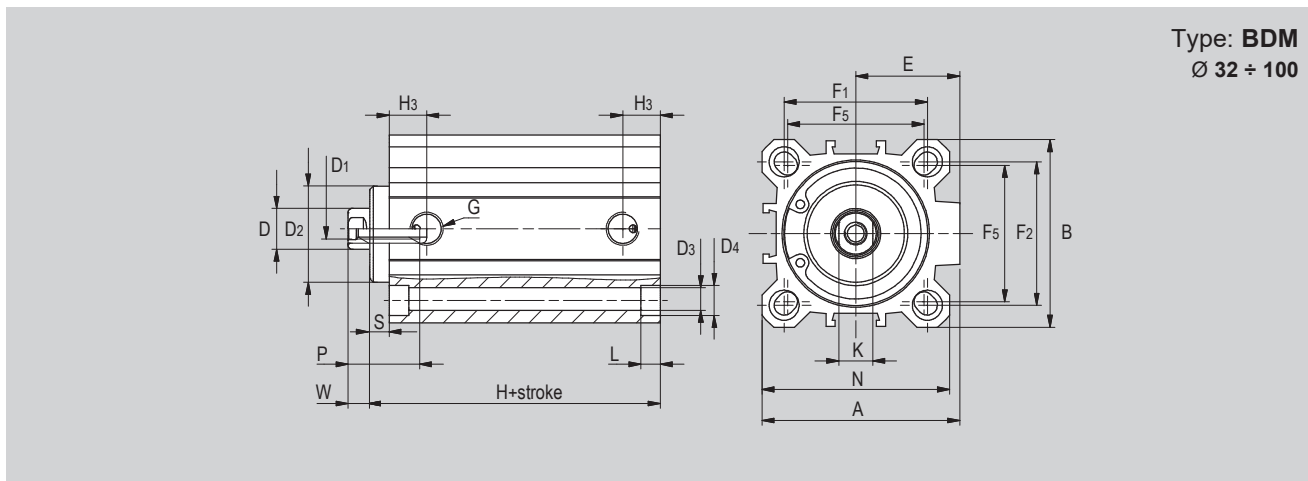
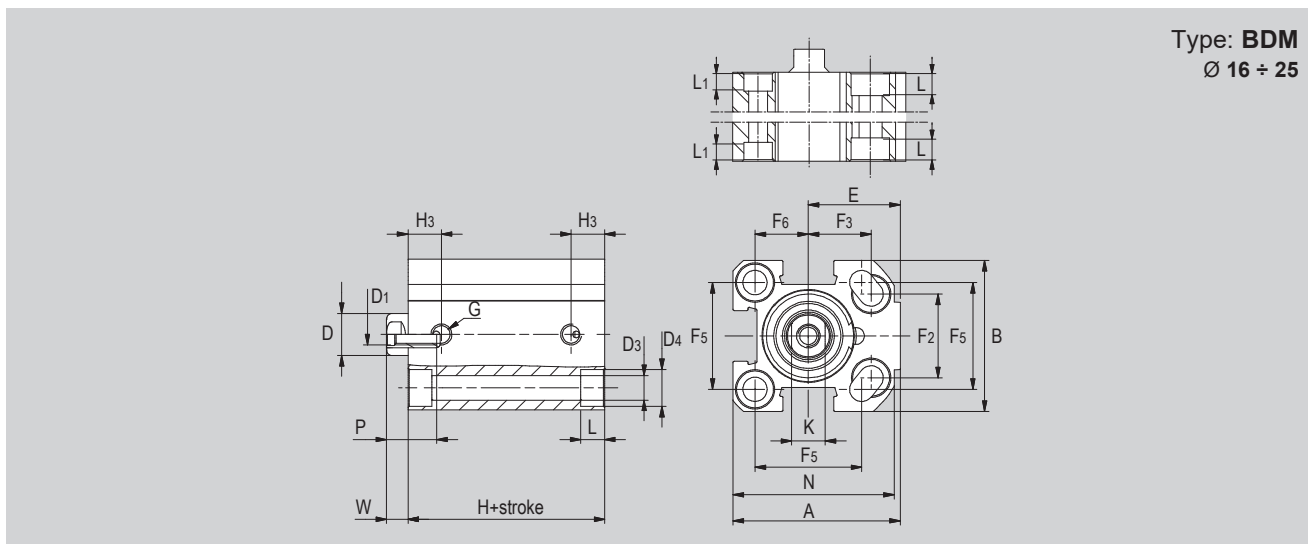
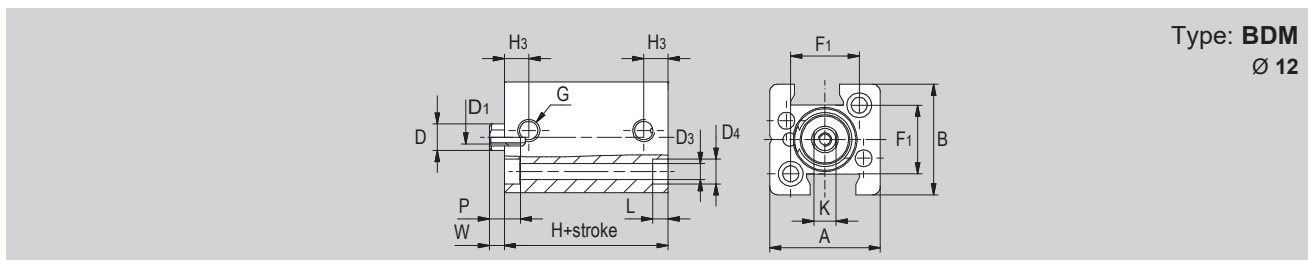

Ø (mm)	A	B	ØD	D ₁	ØD ₂	ØD ₃	ØD ₄	E	G	H	H ₃	F ₁	F ₂	F ₃	F ₅	F ₆	K	L	L ₁	N	P	S	W
12	25	25	6	M3	-	3,7	5,6	-	M5	27	5,5	15,5	-	-	-	-	5	3,5	-	-	7	-	3,5
16	34	30	8	M4	-	4,7	7,5	19	M5	32 ⁽¹⁾	8	-	18	12	20	10	6	4,6	3,5	32	11	-	4,5
20	40	36	10	M5	-	5,8	9	22	M5	32 ⁽¹⁾	8	-	20	15	25,5	12,7	8	5,7	5,7	38,5	12	-	5
25	44,5	40	10	M5	-	5,8	9	24,5	1/8"	38,5 ⁽²⁾	10,5	-	26	15,5	28	14	8	5,7	5,7	42	12	-	5,5
32	51	46	12	M6	24,5	5,8	9	27	1/8"	39,5	11,5	36	32	-	34	-	10	5,7	-	48	15	5	6
40	58	55	12	M6	28	5,8	9	30,5	1/8"	39,5	11 ⁽⁴⁾	42	42	-	40	-	10	5,7	-	55	15	6	6,5
50	70	65	16	M8	34	6,8	11	37,5	1/8"	39,5	11,5	50	50	-	50	-	13	6,8	-	65	17	6	7,5
63	89	80	16	M8	38,5	9	14	46	1/8"	42	11	62	62	-	60	-	13	8,8	-	80	17	8	7
80	105	100	20	M10	44	9	14	55	1/4"	46	14	82	82	-	77	-	17	9	-	100	17	10	8
100	131	124	25	M12	56	11	17,2	69	1/4"	56	16	103	103	-	94	-	22	11	-	124	22	10,5	10

(1) For strokes ≥ 25 mm, add +6 mm to dimension; (2) For strokes ≥ 25 mm, add +1 mm to dimension.

Dimensions with options

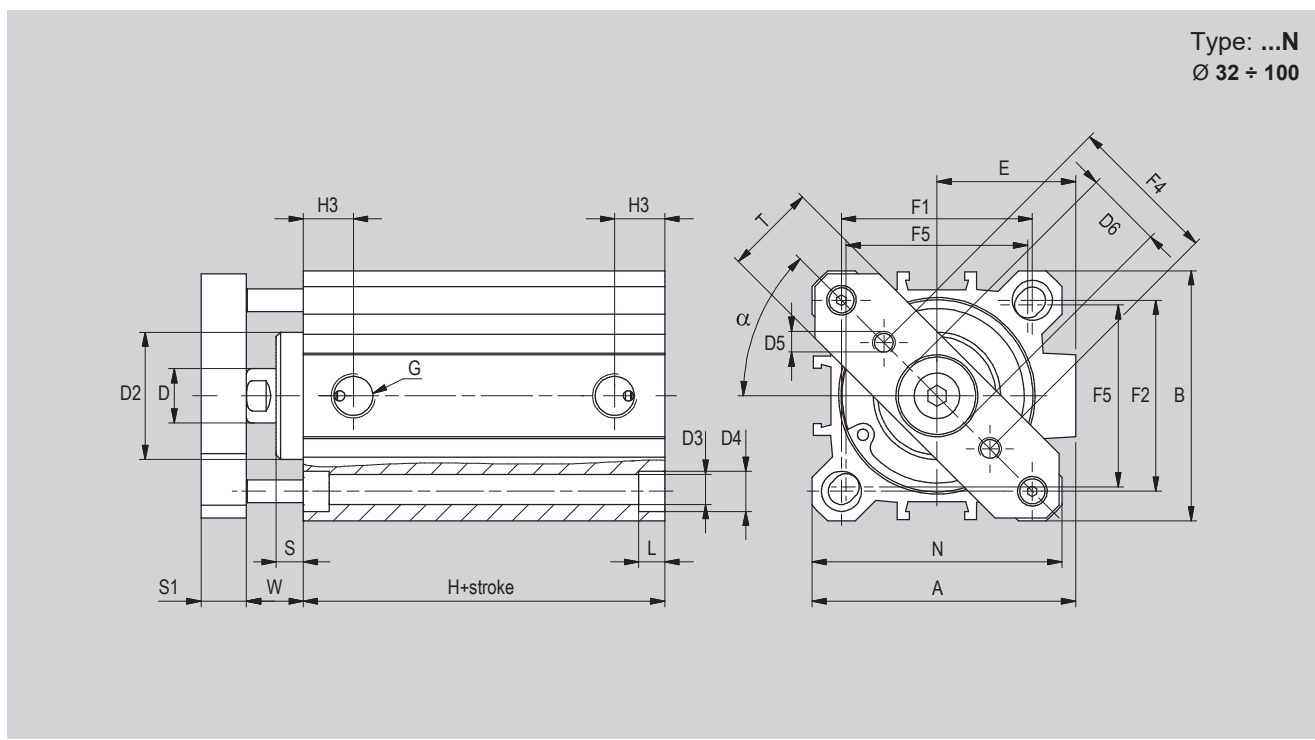
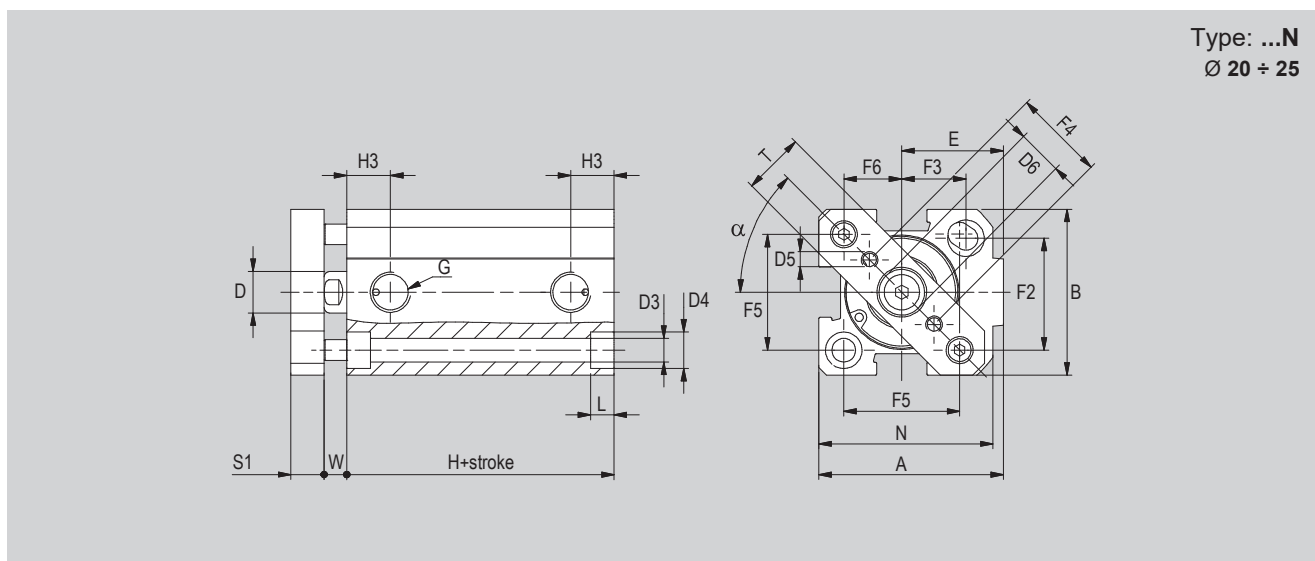

Ø (mm)	A	B	α	ØD	ØD ₂	ØD ₃	ØD ₄	D ₅	ØD ₆	E	G	H	H ₃	F ₁	F ₂	F ₃	F ₄	F ₅	F ₆	K	L	L ₁	N	S	S ₁	T	W
20	40	36	45°	10	-	5,8	9	M4	11	22	M5	32 ⁽¹⁾	8	-	20	15	20	25,5	12,7	8	5,7	5,7	38,5	-	8	15	4,5
25	44,5	40	45°	10	-	5,8	9	M4	11	24,5	1/8"	38,5 ⁽²⁾	10,5	-	26	15,5	22	28	14	8	5,7	5,7	42	-	8	15	5,5
32	51	46	41,5°	12	24,5	5,8	9	M5	17	27	1/8"	39,5	11,5	36	32	-	28	34	-	10	5,7	-	48	5	10	20	11
40	58	55	45°	12	28	5,8	9	M5	17	30,5	1/8"	39,5	11	42	42	-	33	40	-	10	5,7	-	55	6	10	20	12,5
50	70	65	45°	16	34	6,8	11	M6	22	37,5	1/8"	39,5	11,5	50	50	-	42	50	-	13	6,8	-	65	6	12	30	13,5
63	89	80	45°	16	38,5	9	14	M6	22	46	1/8"	42	11	62	62	-	50	60	-	13	8,8	-	80	8	12	30	15
80	105	100	45°	20	44	9	14	M8	28	56	1/4"	46	14	82	82	-	65	77	-	17	9	-	100	10	14	50	18
100	131	124	45°	25	56	11	17,2	M10	30	69	1/4"	56	16	103	103	-	80	94	-	22	11	-	124	10,5	14	50	20,5

(1) For strokes ≥ 25 mm, add +6 mm to dimension; (2) For strokes ≥ 25 mm, add +1 mm to dimension.

Dimensions with options

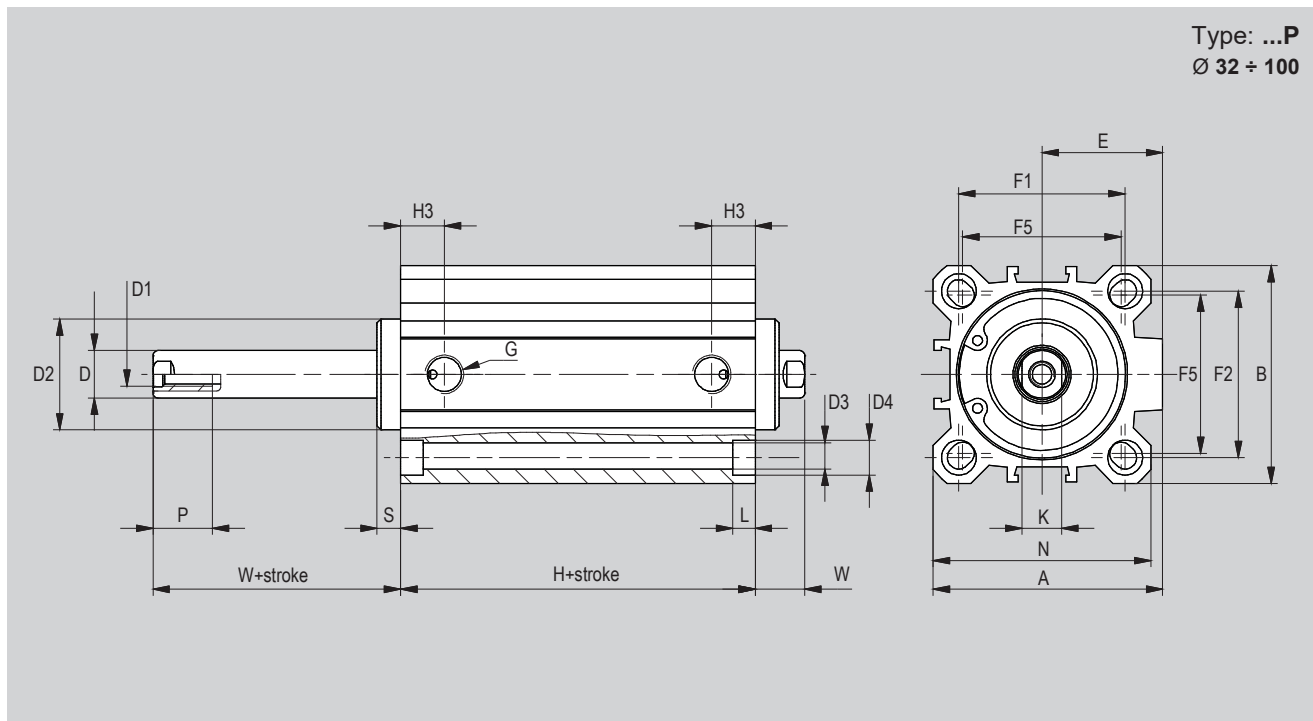
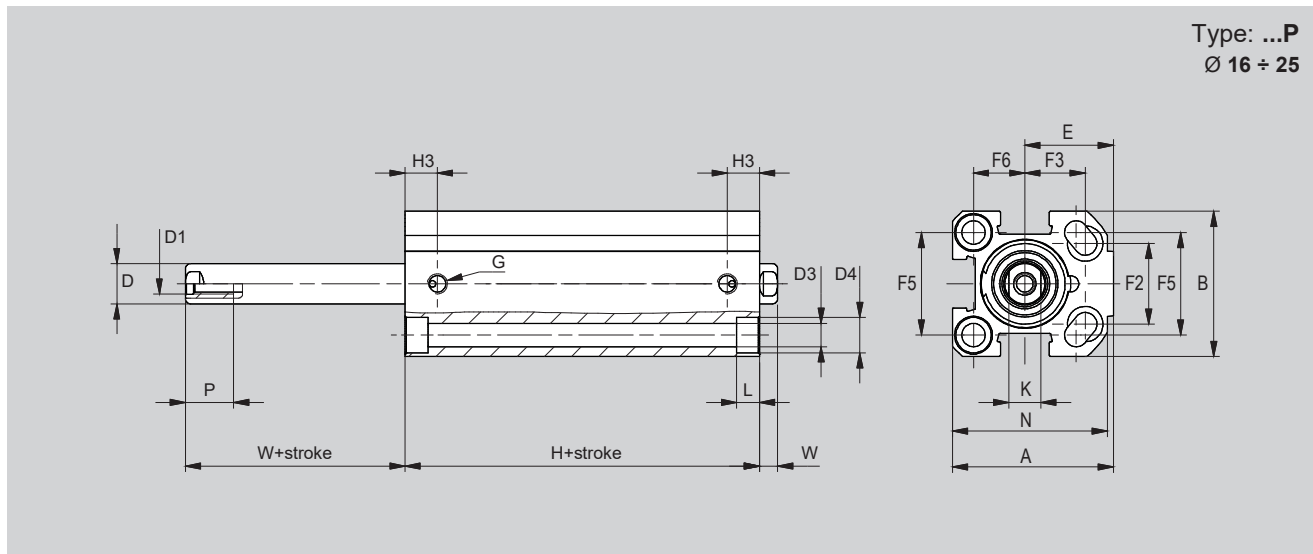

Ø (mm)	A	B	ØD	D ₁	ØD ₂	ØD ₃	ØD ₄	E	G	H	H ₃	F ₁	F ₂	F ₃	F ₅	F ₆	K	L	L ₁	N	P	S	W
16	34	30	8	M4	-	4,7	7,5	19	M5	32 ⁽¹⁾	8	-	18	12	20	10	6	4,6	3,5	32	11	-	4,5
20	40	36	10	M5	-	5,8	9	22	M5	32 ⁽¹⁾	8	-	20	15	25,5	12,7	8	5,7	5,7	38,5	12	-	4,5
25	44,5	40	10	M5	-	5,8	9	24,5	1/8"	38,5 ⁽²⁾	10,5	-	26	15,5	28	14	8	5,7	5,7	42	12	-	5,5
32	51	46	12	M6	24,5	5,8	9	27	1/8"	39,5	11,5	36	32	-	34	-	10	5,7	-	48	15	5	11
40	58	55	12	M6	28	5,8	9	30,5	1/8"	39,5	11	42	42	-	40	-	10	5,7	-	55	15	6	12,5
50	70	65	16	M8	34	6,8	11	37,5	1/8"	39,5	11,5	50	50	-	50	-	13	6,8	-	65	17	6	13,5
63	89	80	16	M8	38,5	9	14	46	1/8"	42	11	62	62	-	60	-	13	8,8	-	80	17	8	15
80	105	100	20	M10	44	9	14	55	1/4"	46	14	82	82	-	77	-	17	9	-	100	17	10	18
100	131	124	25	M12	56	11	17,2	69	1/4"	56	16	103	103	-	94	-	22	11	-	124	22	10,5	20,5

(1) For strokes ≥ 25 mm, add +6 mm to dimension; (2) For strokes ≥ 25 mm, add +1 mm to dimension.

Accessories for short stroke cylinders

Rod nipple N..AQB

	For cylinder Ø mm	Code	Item	Filetto 1	Filetto 2
	12	040079	N6-3AQB	M6x1	M3x0,5
16	040080	N6-4AQB	M6x1	M4x0,7	
20-25	040081	N8-5AQB	M8x1,25	M5x0,8	
32-40	040082	N10-6AQB	M10x1,25	M6x1	
50-63	040083	N12-8AQB	M12x1,25	M8x1,25	
50-63	040084	N16-8AQB	M16x1,5	M8x1,25	
80	040085	N16-10AQB	M16x1,5	M10x1,5	
100	040086	N20-12AQB	M20x1,5	M12x1,75	

Female clevis* with clip FF..ISO

	For cylinder Ø mm	Code	Item	Compliance
	12-16	041002	FF06ISO/DIN	
20-25	041003	FF08ISO/DIN		
32-40	041004	FF10ISO		
50-63	041005	FF12ISO		
50-63-80	041006	FF16ISO		
100	041007	FF20ISO		

*Matching only with rod nipple N..AQB mounted

Female clevis* with pin and seeger FFP..ISO

	For cylinder Ø mm	Code	Item	Compliance
	12-16	-	FFP06ISO/DIN	
20-25	-	FFP08ISO/DIN		
32-40	041051	FFP10ISO		
50-63	041040	FFP12ISO		
50-63-80	041013	FFP16ISO		
100	041017	FFP20ISO		

*Matching only with rod nipple N..AQB mounted

Female clevis* (body only) FFN..ISO

	For cylinder Ø mm	Code	Item	Compliance
	12-16	041011	FFN06ISO/DIN	
20-25	041018	FFN08ISO/DIN		
32-40	041014	FFN10ISO		
50-63	041016	FFN12ISO		
50-63-80	041012	FFN16ISO		
100	041015	FFN20ISO		

*Matching only with rod nipple N..AQB mounted

Bearing head (DIN 648K) with female thread* RF..SE

	For cylinder Ø mm	Code	Item	Compliance
	12-16	041552	RF6SE	
20-25	041553	RF8SE		
32-40	041554	RF10SE		
50-63	041555	RF12SE		
50-63-80	041557	RF16SE		
100	041559	RF20SE		

*Matching only with rod nipple N..AQB mounted

Bearing head (DIN 648K) with male thread RM..SE

	For cylinder Ø mm	Code	Item	Compliance
	16	041500	RM4SE	
20-25	041501	RM5SE		
32-40	041502	RM6SE		
50-63	041503	RM8SE		
80	041550	RM10SE		
100	041514	RM12SE		

Axial articulated coupling* RBI..

	For cylinder Ø mm	Code	Item	Compliance
	12-16	041602	RBI6	-
20-25	041603	RBI8		
32-40	041604	RBI10		
50-63	041605	RBI12		
50-63-80	041607	RBI16		
100	041609	RBI20		

*Matching only with rod nipple N..AQB mounted

Angular articulated coupling* RBL..

	For cylinder Ø mm	Code	Item	Compliance
	12-16	041652	RBL6	-
20-25	041653	RBL8		
32-40	041654	RBL10		
50-63	041655	RBL12		
50-63-80	041657	RBL16		
100	041659	RBL20		

*Matching only with rod nipple N..AQB mounted

Accessories for short stroke cylinders

1 - CYLINDERS

Self-aligning articulated coupling* GB..

	For cylinder Ø mm	Code	Item	Compliance
	12-16	041702	GB010	-
20-25	041703	GB020		
32-40	041704	GB040		
50-63	041706	GB060		
50-63-80	041708	GB100		
100	041709	GB120		

*Matching only with rod nipple N..AQB mounted

Self-aligning coupling* GC..

	For cylinder Ø mm	Code	Item	Compliance
	32-40	041722	GCM10x1,25	-
50-63	041723	GCM12x1,25		
50-63-80	041724	GCM16x1,5		
100	041725	GCM20x1,5		

*Matching only with rod nipple N..AQB mounted

Back head with integrated rear eye* in aluminium CM..ALB

	For cylinder Ø mm	Code	Item	Compliance
	16	040070	CM16ALB	-
20	040071	CM20ALB		
25	040072	CM25ALB		
32	040073	CM32ALB		
40	040074	CM40ALB		
50	040075	CM50ALB		
63	040076	CM63ALB		
80	040077	CM80ALB		
100	040078	CM100ALB		

Accessory to be ordered together with the cylinder

High foot in aluminium P..ALB

	For cylinder Ø mm	Code	Item	Compliance
	16	040087	P16ALB	-
20	040088	P20ALB		
25	040095	P25ALB		
32	040089	P32ALB		
40	040090	P40ALB		
50	040091	P50ALB		
63	040092	P63ALB		
80	040093	P80ALB		
100	040094	P100ALB		

Stainless Steel seeger for front head SGX..

	For cylinder Ø mm	Code	Item	Compliance
	25	171315	SGX025	-
32	171316	SGX032		
40	171317	SGX040		
50	171318	SGX050		
63	171319	SGX063		
80	171320	SGX080		
100	171321	SGX100		

Bracket AS108 (for magnetic reed switches T groove)

	For cylinder Ø mm	Code	Item	Cylinder matching
	12 ÷ 100	072915	AS108	BSM BDM

Magnetic reed switch T groove ASV..

	For cylinder Ø mm	Code	Item	Cylinder matching
	12 ÷ 100	070946	ASV1C525	BSM* BDM*
071863		ASV1C550		
071864		ASV1C51K		
071189		ASV1C5M8		
073639		ASV4D225		
070246		ASV4D2M8		
074900		ASV7N225		
070247		ASV7N2M8		
070372		ASV7M2M8		
072918		ASV1H525		

*With bracket AS.. for magnetic reed switches T groove

ATEX magnetic reed switch T groove MK..

	For cylinder Ø mm	Code	Item	Compliance	Cylinder matching
	12 ÷ 100	071120	MK500A	Ex 3D	BSM* BDM*
071108		MK502A	Ex II1G		

*With bracket AS.. for magnetic reed switches T groove