

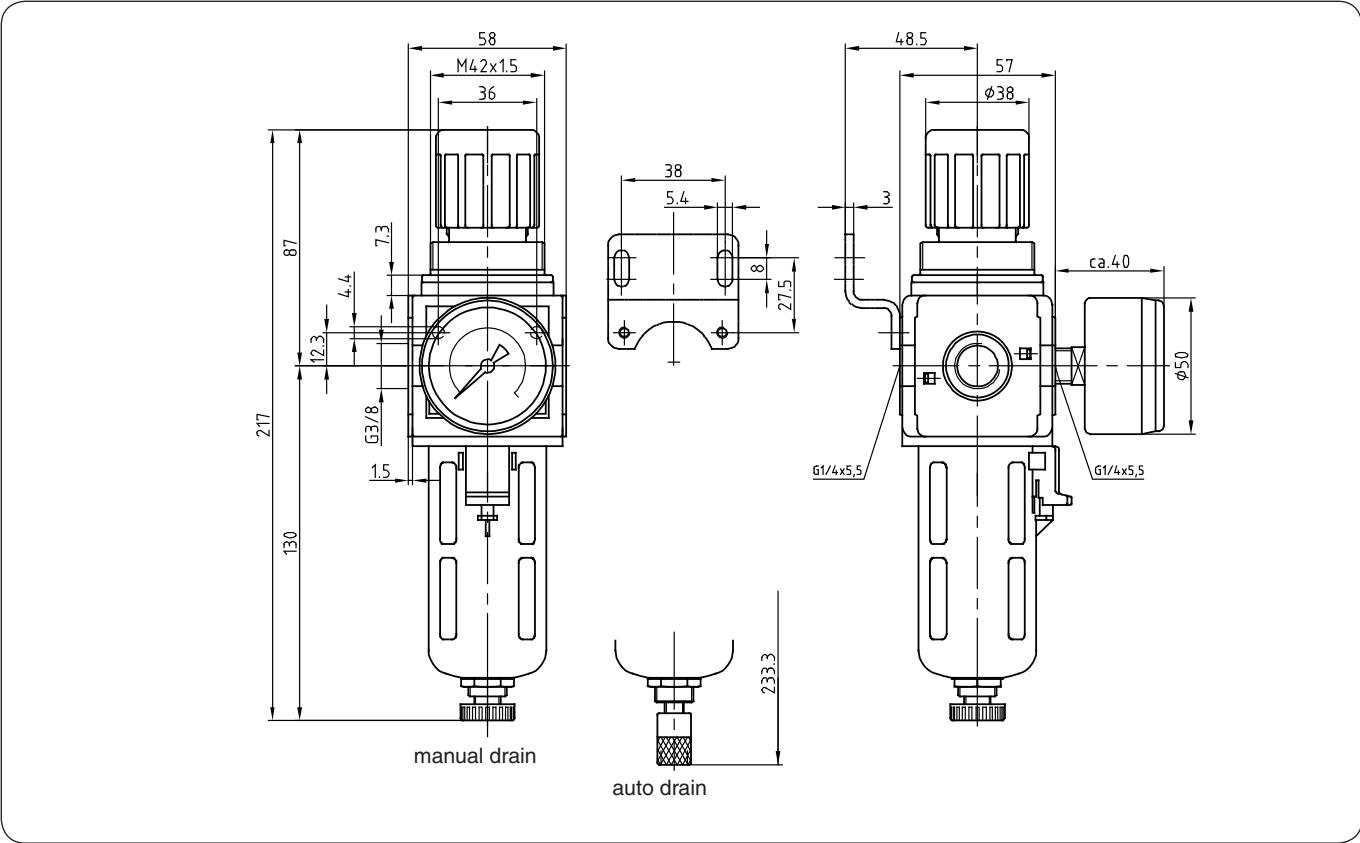

## dimensions (mm)

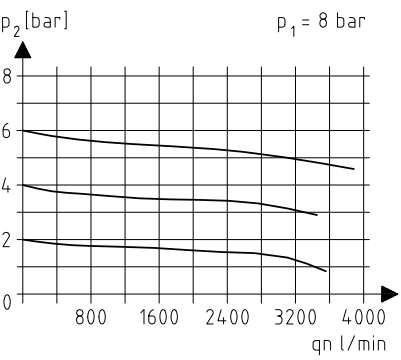

### flow characteristics



### pressure characteristic

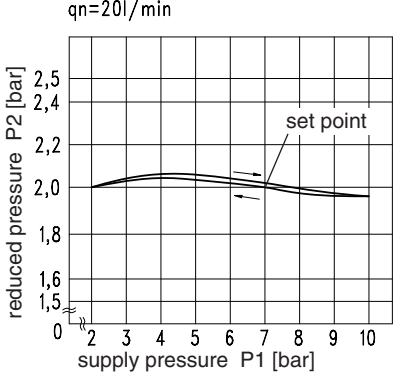

### accessories

**gauge**

type:  
G 50.6 R  
G 50.10 R  
G 50.16 R  
G 50.25 R

**auto drain**

type: AM 10

**panel mounting ring M 42 x 1,5**

type: SM-2

**mounting bracket**

type: ZW.22

**spring**

type:  
0,1- 3: C.22-81  
0,2- 6: C.22-82  
0,5-16: C.22-66

**spring**

type:  
0,1- 3: C.22-81  
0,2- 6: C.22-82  
0,5-16: C.22-66

technical modifications keep in reserve!

page: C.22 (08/08)