

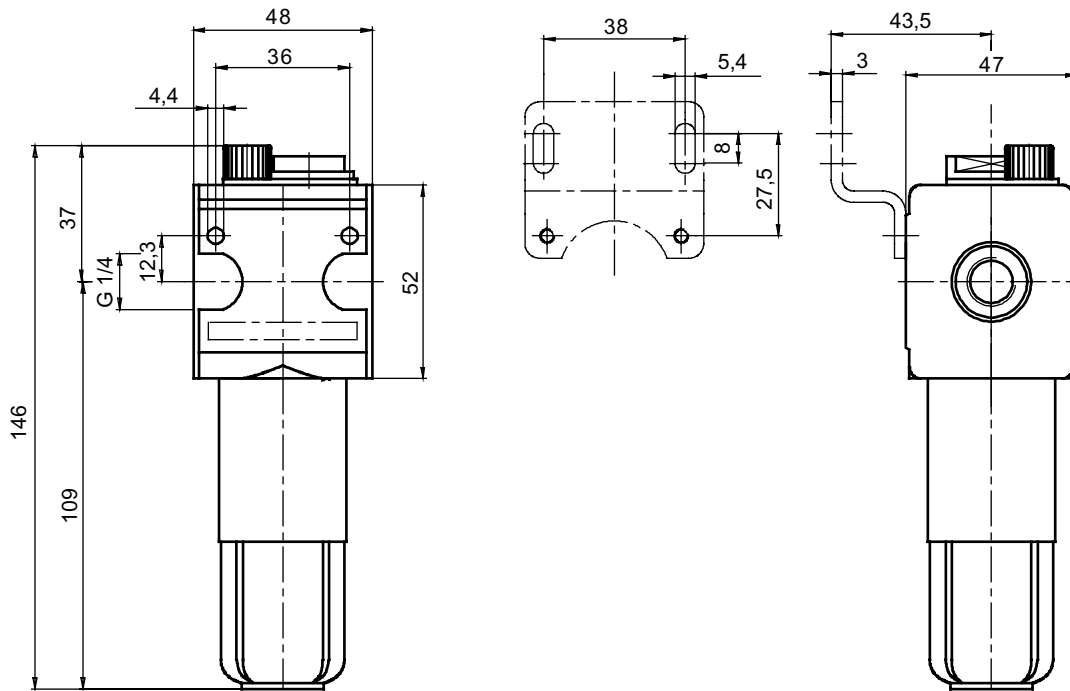

## dimensions (mm)

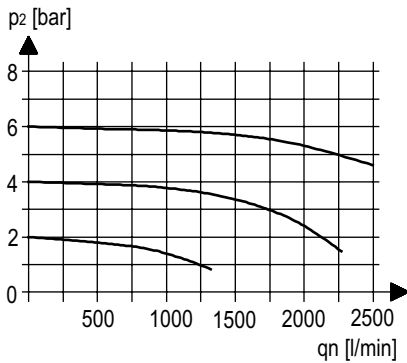

## flow characteristics



## oil consumption

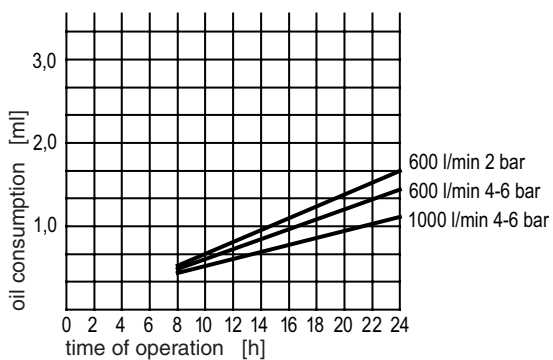

## accessories

mounting bracket

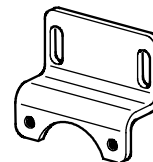

type: ZW.11

bowl guard

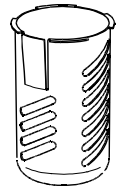

type: C.11-45

metal bowl

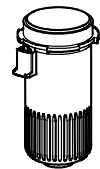

type: BL.11 M

metal bowl (sight glass)

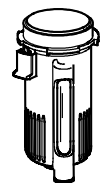

type: BL.11 H