

Rotary actuators with ball valve

Limit switch box

Standard executions			
Version	Limit switch code	Code	Item
SB200	ZM50G10B01	811188	SB200M012
	ZM10G10B01	811189	SB200M022
	NBB2-V3-E2	811190	SB200P112
	IS5076	811191	SB200P122
	NCB2-V3-NO	811192	SB200P132
	ALMS-5-240	811193	SB200Q512
SB500	83261	811194	SB500M032
	83268	811195	SB500M042
	NBBB2-V3-E2	811196	SB500P112
	IS 5076	811197	SB500P122
	NCB2-V3-NO	811198	SB500P132
	ALMS-5-240	811199	SB500Q512
SB700	LS SILVER	811200	SB700M052
	NBBB2-V3-E2	811208	SB700P112
	IS576	811209	SB700P122
	NCB2-V3-NO	811210	SB700P132



CE **Ex** **II 2G Ex db IIB T6 Gb**

SB500 supplied according to 2014/34/EU - **ATEX**

Aluminum switch boxes painted with epox powder black (SB200 and SB300), supplied complete with universal adjustable brackets for assembly on our full range of actuators (L=30x80/130-H=20/30).

These devices are particularly suitable for monitoring the position of each valve, even at long distances, they can contains mechanical or proximity limit switches.

SB200 and SB500 are supplied with tridimensional position indicator yellow/red and 8 wire points standard (two free for eventual electrovalve attachment in box). SB700 is supplied with tridimensional position indicator green/red and 10 wire-points standard (four free for eventual electrovalve attachment in box). There is plenty of room to facilitate all wiring procedures, on installation.

Screws on the box cover are self-locking and unlosable, cam easy to set without tools, don't need any further adjustment after initial setting.

Technical data dei box di finecorsa			
Class protection	SB200: IP67 - SB500: IP66 - SB700: IP65		
Temperature range	SB200: -25°C ÷ +80°C	SB500: -20°C ÷ +50°C (standard), -40°C ÷ +50°C (option)	SB700: -15°C ÷ +80°C
Connections	SB200 - SB500: M20x1.5 (x2)		SB700: 1/2" G (x2)
Terminal strip	SB200 - SB500: 8 wire points		SB700: 10 wire points
Position indicator	0° ÷ 90°		
Open / Closed	SB200 - SB500: Yellow / Red		SB700: Green / Red

Materials		
	SB200 - SB500	SB700
Cover:	Aluminium alloy	Polycarbonate
Body:	Aluminium alloy	PPO
Shaft:	Stainless steel	PA
Indicator cover:	Polycarbonate	ABS
Indicator:	ABS, polycarbonate	ABS
Terminal strip:	Polycarbonate, brass, stainless steel	-
Cam:	Polycarbonate	Polycarbonate
Spring:	Stainless steel	Stainless steel
Screws:	Stainless steel	Stainless steel
O-ring:	NBR	NBR
Earthing screw:	Stainless steel	-

Type: **SB200**

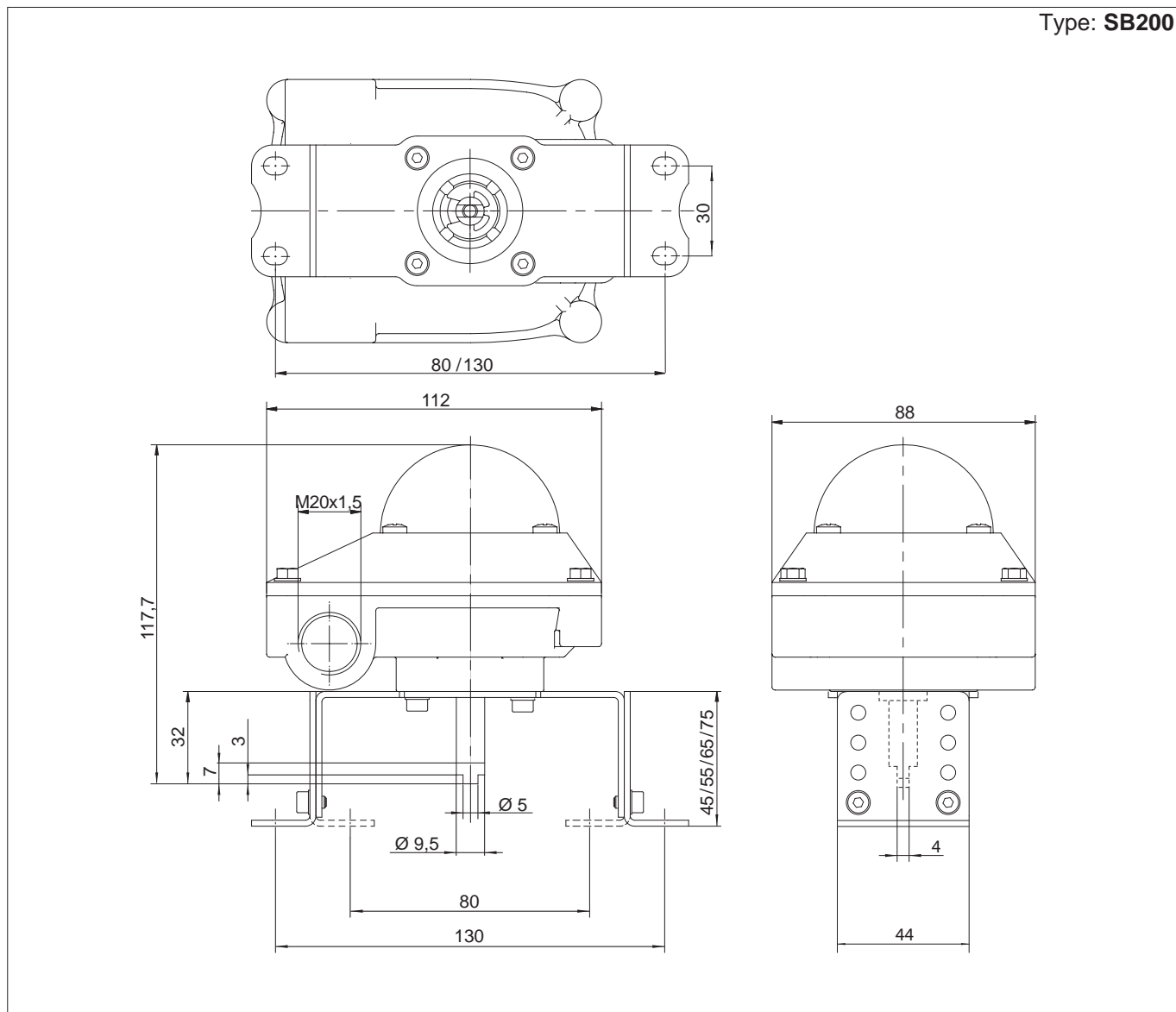

2

	Mechanical		Proximity			Magnetic
Code	811188	811189	811190	811191	811192	811193
Item	SB200M012	SB200M022	SB200P112	SB200P122	SB200P132	SB200Q512
Limit switch manufacturer	Honeywell		Peppri Fuchs	IFM	Pepperl Fuchs	ALMS
Limit switch code	QM50G10B01	QM50G10B01-G	NBB2-V3-E2	IS5076	NCB2-V3-NO	ALMS-5-240
Ex identification	-		Ex ia IICT6	-	Ex ia IICT6	-
Contacts	Silver	Gold	-			-
Function	SPDT		PNP	PNP / NPN	NAMUR NC	-
Number of wires	3		3	2	2	3
Voltage	125 ÷ 250 VAC	0 ÷ 125 VAC	10 ÷ 30 VDC	5 ÷ 36 VDC	8 VDC	5 ÷ 240 V AC/DC
Intensity	5 A	0,1 A	0 ÷ 100 mA	0 ÷ 200 mA	-	≤ 300 mA
Switching frequency	-		0 ÷ 1000 Hz	0 ÷ 2000 Hz	0 ÷ 2000 Hz	60 Hz
N° wiring diagram	1		2	2/3	4	5
Limit switch code	01	02	11	12	13	51
Q.ty of limit switch	2	2	2	2	2	2

Type: **SB500**

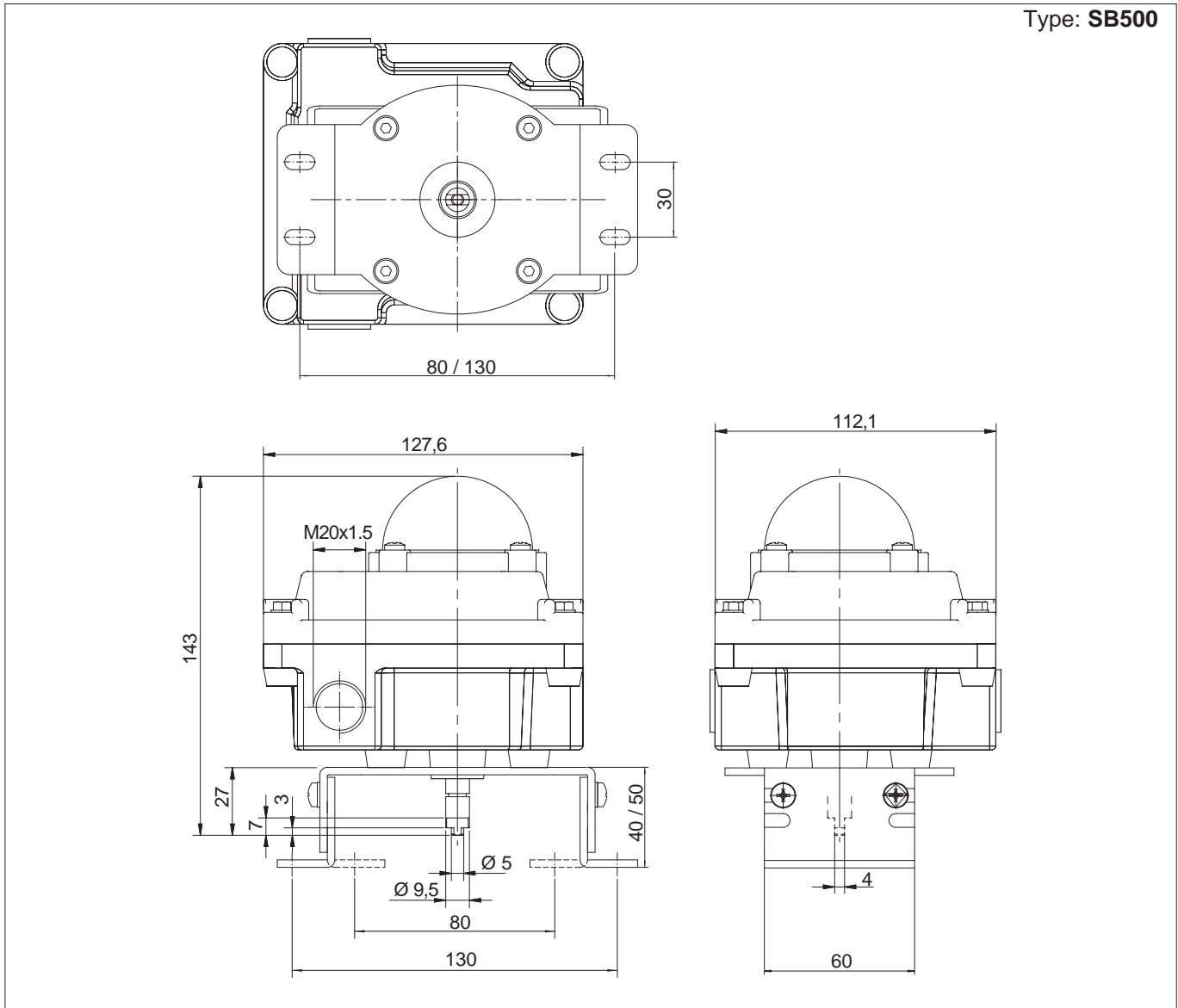

	Mechanical		Proximity			Magnetic
Code	811194	811195	811196	811197	811198	811199
Item	SB500M012	SB500M022	SB500P112	SB500P122	SB500P132	SB500Q512
Limit switch manufacturer	Honeywell		Peppri Fuchs	IFM	Pepperl Fuchs	ALMS
Limit switch code	V15T16SZ200A05	QM50G10B01-G	NBB2-V3-E2	IS5076	NCB2-V3-NO	ALMS-5-240
Ex identification	-		Ex ia IICT6	-	Ex ia IICT6	-
Contacts	Silver	Gold	-			-
Function	SPDT		PNP	PNP / NPN	NAMUR NC	-
Number of wires	3		3	2	2	3
Voltage	125 ÷ 250 VAC	30 VAC / 125 VAC	10 ÷ 30 VDC	5 ÷ 36 VDC	8 VDC	5 ÷ 240 V AC/DC
Intensity	16 A	0,1 A	0 ÷ 100 mA	0 ÷ 200 mA	-	≤ 300 mA
Switching frequency	-		0 ÷ 1000 Hz	0 ÷ 2000 Hz	0 ÷ 2000 Hz	60 Hz
N° wiring diagram	1		2	2/3	4	5
Limit switch code	03	04	11	12	13	51
Q.ty of limit switch	2	2	2	2	2	2

Type: **SB700**

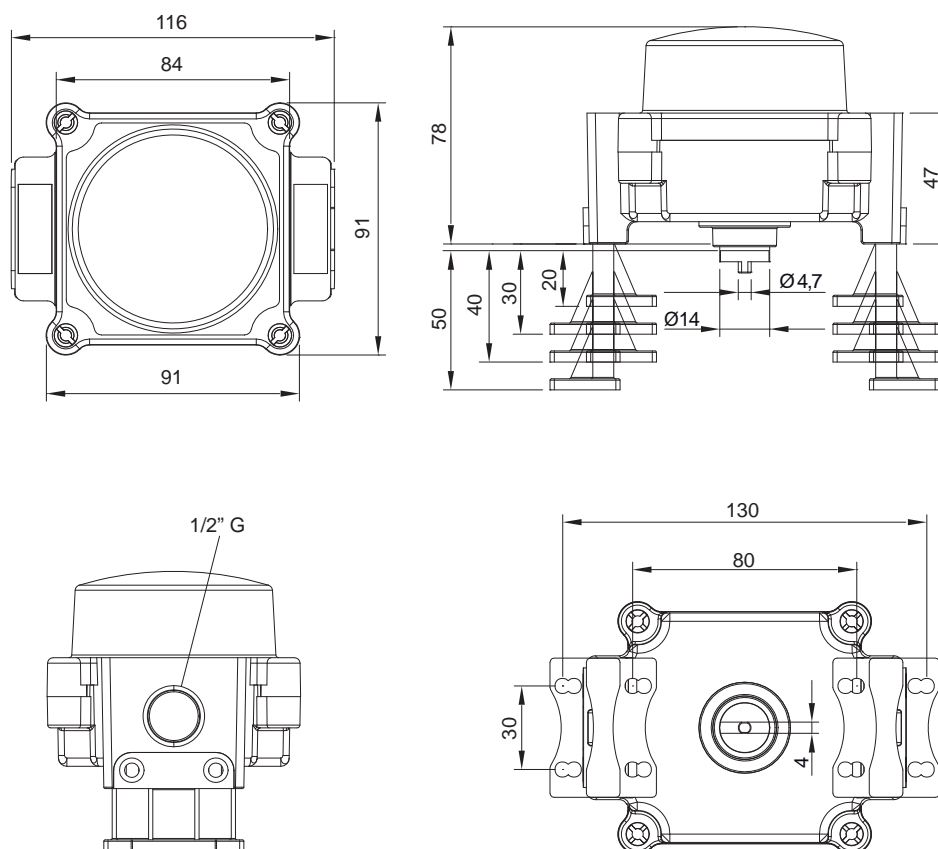

2

Code	Mechanical		Proximity		
	811200	811208	811209	811210	
Item	SB700M052	SB700P112	SB700P122	SB700P132	
Limit switch manufacturer	E-switch	Peppri Fuchs	IFM	Pepperl Fuchs	
Limit switch code	LS silver	NBB2-V3-E2	IS5076	NCB2-V3-NO	
Ex identification	-	Ex ia IIC T6	-	Ex ia IIC T6	
Contacts	Silver	-	-	-	
Function	SPDT	NPN	PNP / NPN	NAMUR NC	
Number of wires	3	3	2	2	
Voltage	125 ÷ 250 VAC	10 ÷ 30 VDC	5 ÷ 36 VDC	8 VDC	
Intensity	15 A	0 ÷ 100 mA	0 ÷ 200 mA	-	
Switching frequency	-	0 ÷ 1000 Hz	0 ÷ 2000 Hz	0 ÷ 2000 Hz	
N° wiring diagram	1	2	3	4	
Limit switch code	05	11	12	13	
Q.ty of limit switch	2	2	2	2	

Rotary actuators with ball valve

Limit switch box - Wiring diagram

	<p>N° wiring diagram: 1</p> <p>Function: SPDT</p> <p>Type: Mechanical</p>
	<p>N° wiring diagram: 2</p> <p>Function: PNP</p> <p>Type: Proximity</p>
	<p>N° wiring diagram: 3</p> <p>Function: NPN</p> <p>Type: Proximity</p>
	<p>N° wiring diagram: 4</p> <p>Function: NAMUR CN</p> <p>Type: Proximity</p>
	<p>N° wiring diagram: 5</p> <p>Function: SPDT</p> <p>Type: Magnetic</p>