

PSPH Series

Heavy-duty Type Level Compensator



Features

- ◇ Heavy-duty spring for heavy-duty applications.
- ◇ Built-in oil free bushing has good wear resistance, which enhances life time.

Applications

- ◇ Suitable for applications where there is height difference.
- ◇ For condition in which shock absorption is required during handling process.
- ◇ For condition of short operating cycle and fast movement.

How to order

PSPH - E 25 G3M - M30

① ② ③ ④ ⑤

① Series	② Buffer style	③ Buffer stroke	④ Suction cup connection	⑤ Mounting thread
PSPH	E - External spring	25 75 50 90	G3M - G3/8 Male thread G4M - G1/2 Male thread	M30 - M30×1.5

Dimensions (mm)

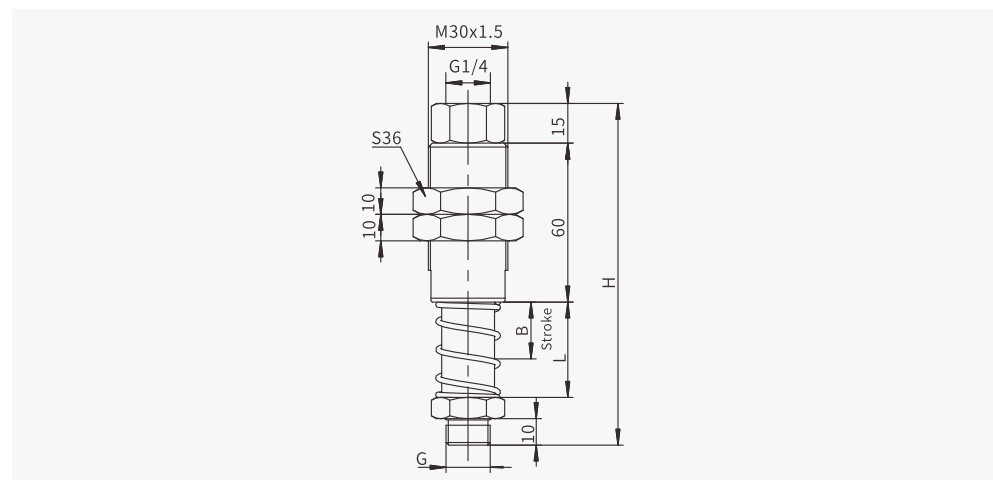

Model	G	B	L	H	F1(N)	F2(N)
PSPH-E25G3M-M30	G3/8	25	36	129	24	74
PSPH-E50G3M-M30		50	65	158	17	77
PSPH-E75G3M-M30		75	107	200	41	79
PSPH-E90G3M-M30		90	119	212	29	74
PSPH-E25G4M-M30	G1/2	25	36	129	24	74
PSPH-E50G4M-M30		50	65	158	17	77
PSPH-E75G4M-M30		75	107	200	41	79
PSPH-E90G4M-M30		90	119	212	29	74

◇Note: "F1 "means spring force at 0 stroke, F2 means spring force at max stroke.