

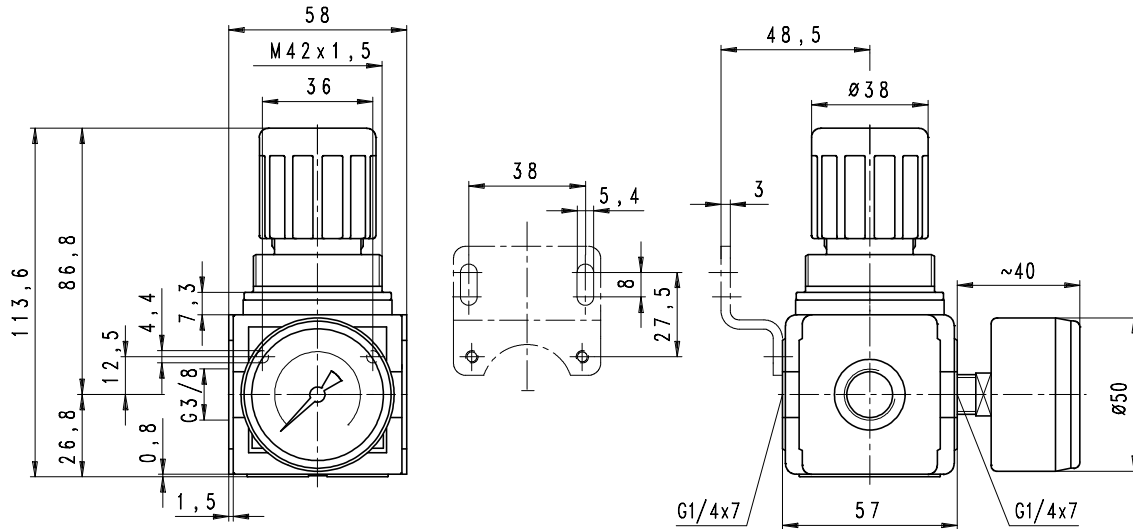

## dimensions (mm)

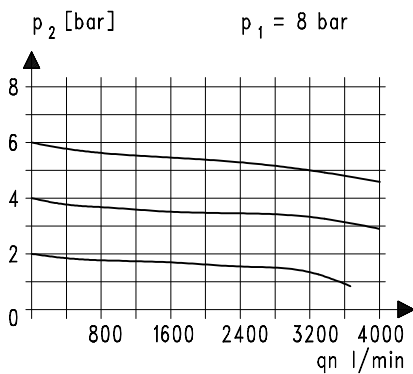

## flow characteristics



## pressure characteristic

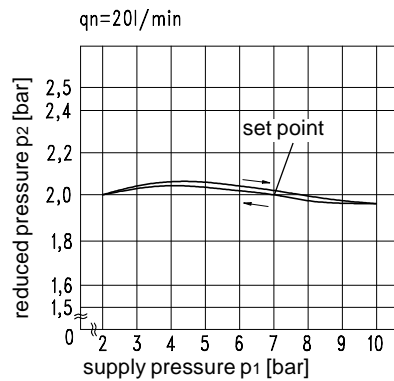

## accessories

### gauge

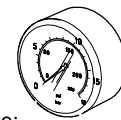

type:  
G 50. 3/ 6 R  
G 50. 6/10 R  
G 50.10/16 R  
G 50.16/25 R

### spring

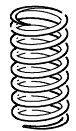

type:  
0,1- 3: C.22-81  
0,2- 6: C.22-82  
0,5-16: C.22-66

### panel mounting ring M 42 x 1,5



type: C.22-42

### mounting bracket

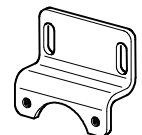

type: ZW.22