

dimensions (mm)

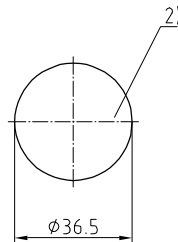

- 1) pressure gauge $\phi 25$
- 2) opening for control panel assembly

flow characteristics

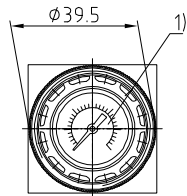
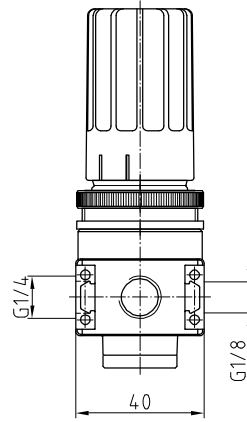
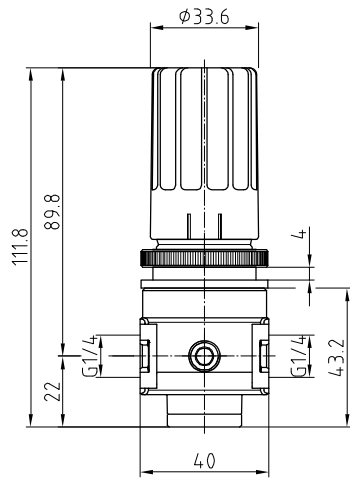
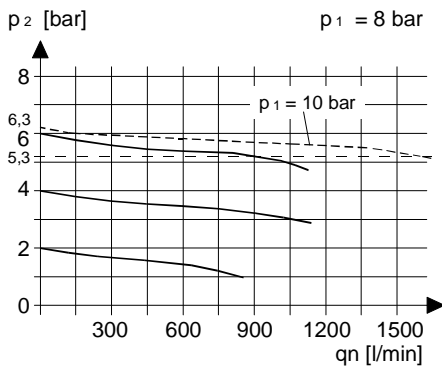

pressure characteristic

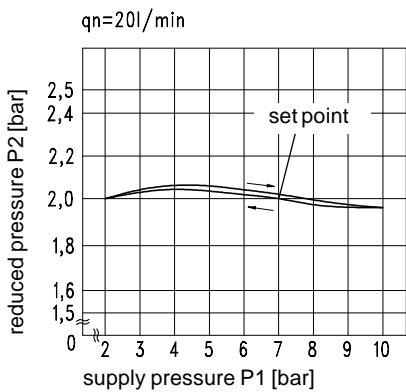

accessories

