

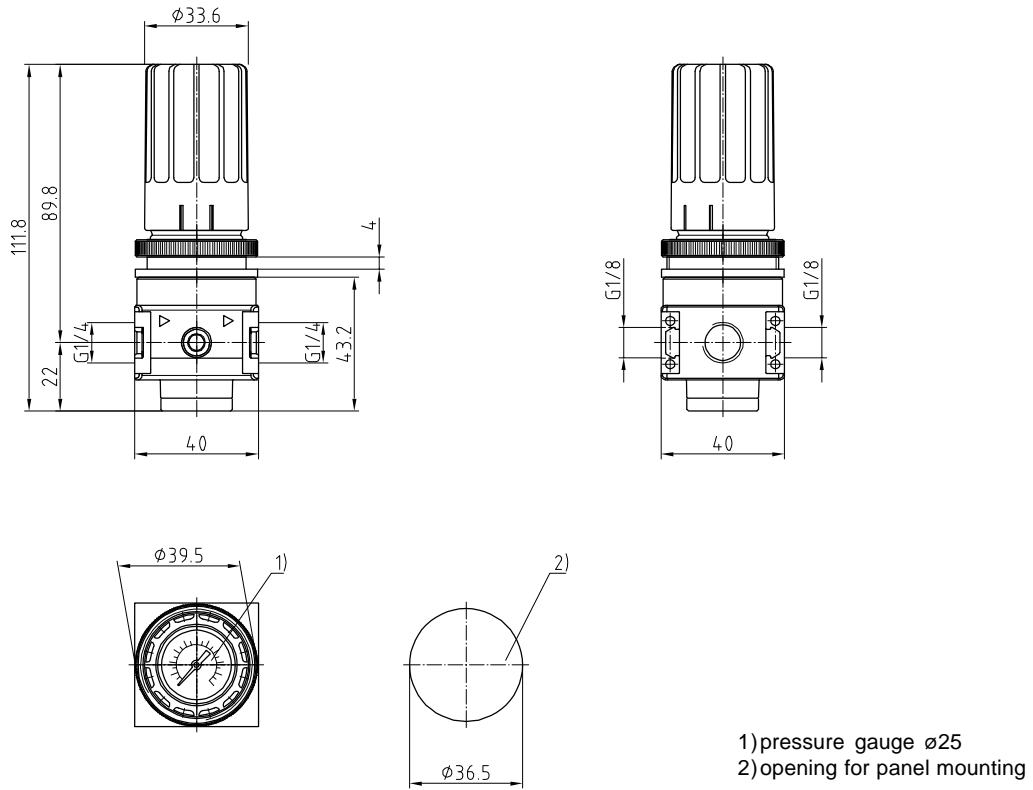

## dimensions (mm)

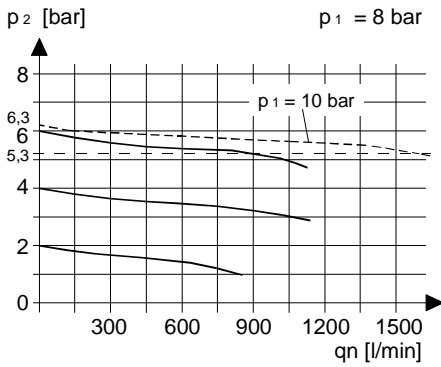

## flow characteristics



## pressure characteristic

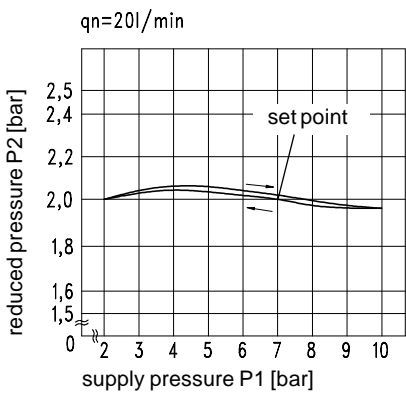

## accessories

