

STAINLESS STEEL

round cylinders Series RXD



Find out our
key products



Solution for most applications



Easy and intuitive choice



Excellent value for money



Wide availability



Fast delivery



Stainless Steel round cylinders

Series RXD

Main features and certifications

Series of Stainless Steel AISI 316L Round Cylinders in bores from Ø 32 to 63, double acting, magnetic with adjustable cushionings. Supplied as standard in compliance to Reach and RoHS directives, and SIL certified. Lubrication with synthetic grease long lasting, for applications with low start up, granting low friction and a permanent lubrication film. Fully composed by non-toxic elements conforming to FDA Directive section 21 CFR 178 about accidental contact with food (registered NSF H1). On request, can be also supplied according to the 2014/34/EU ATEX Directive.



Series RXD Ø 32 ÷ 63

from page 5.11.10



Stainless Steel AISI 316L Round Cylinders, available in bores from Ø 32 to 63, double acting magnetic with adjustable cushioning, characterized by an essential design to prevent the accumulation of impurities. The cylinder body surface is smooth with no chamfers or cavities where dirt could settle. The rod seal is in special polyurethane developed for chemical and food&beverage. These features make these cylinders particularly suitable for the food&beverage, chemical, pharmaceutical and medical fields, and in general for all applications where maximum hygiene and cleaning are required, even in corrosive environments. Various configurations are possible, some of which make the cylinder with ISO dimensions.

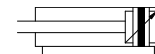

Options		
Description	Symbol	Suffix
Through rod		P
FKM seals	-20°C ÷ +150°C	V
FKM rod seal	-20°C ÷ +80°C	V1
Low temperature seals	-40°C ÷ +80°C	BT
Extended rod (indicate the requested WH dimension in mm, E.g.: WH=100; for further information please contact the sales department)		WH=..
Without adjustable cushionings		D
Adjustable rear cushioning only		D1
Adjustable front cushioning only		D2
Special male thread (indicate the requested thread. E.g.: R-M 10x1,5; the dimension AM of the special thread will be the same as the standard; cylinder will be supplied without rod nut; for further information please contact the sales department)		R-M..
NBR rod seal	-20°C ÷ +80°C	H1
ATEX versions on request		/ATEX
Special versions on request		/S

The options, when this is possible, can be combined with each other. For options matching see from page 5.11.4; For code key see from page 5.11.6.

Stainless Steel round cylinders

Series RXD

Options matching

Series	Bore	Type	Standard options matching			
			P	V	V1	BT
RXD	Ø 32 ÷ 63	with front threaded end cap (VA)	●	●	●	●
		with front and rear threaded end caps (VD)	-	●	●	●
		with 4 female threaded holes on rear end cap (FP)	-	●	●	●
		with ISO MP4 rear eye (CM)	-	●	●	●
		with ISO MP6 narrow rear eye (CS)	-	●	●	●
		with ISO AB6 narrow rear clevis (CF)	-	●	●	●
		with pins on front end cap (BA)	-	●	●	●
		with pins on rear end cap (BP)	-	●	●	●

Key

● matching accessory; - not matching accessory

Options matching - note

- (1) Option **WH=.** require to indicate the desired dimension in mm; for models with through rod option (**P**) the extended rod option (**WH=.**) is applied only to one side of the rod. For further information please contact the sales department.
- (2) Option **R-M.** require to indicate the desired thread; for models with through rod option (**P**) the special male thread option (**R-M.**) are applied on both sides of the rod. For further information please contact the sales department.

Standard options matching

WH=.. ⁽¹⁾	D	D1	D2	R-M.. ⁽²⁾	H1	/ATEX
•	•	•	•	•	•	•
•	•	•	•	•	•	•
•	•	•	•	•	•	•
•	•	•	•	•	•	•
•	•	•	•	•	•	•
•	•	•	•	•	•	•
•	•	•	•	•	•	•
•	•	•	•	•	•	•
•	•	•	•	•	•	•

Stainless Steel round cylinders
Series RXD

Code key

Bore	/	Stroke	Series	Type
40	/	80	RXD	VA

Ø 32, 40, 50, 63

10 mm ÷ 1000 mm

RXD
Double acting
Magnetic
With adjustable
cushionings

Suffix	testata anteriore	testata posteriore
VA Front threaded end cap		
VD Front and rear threaded end caps		
FP Four female threaded holes on rear end cap		
CM Rear eye		
CS Narrow rear eye		
CF Narrow rear clevis		
BA Pins on front end cap		
BP Pins on rear end cap		

How to order

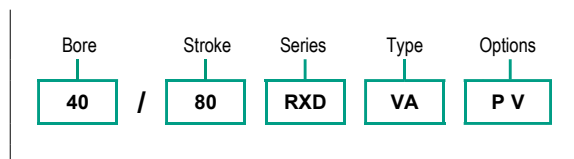

Notes

For standard materials see the side table. Options in the same grid are alternative to each others.
For further information on options and their matching, see page 5.11.3 and 5.11.4
For further information on the ATEX 2014/34/EU Directive, on classifications and protections, see from page III.1
(1) Available for type RXDVA only

Standard* seal kit

Number of components	Description
n. 1	Rod seal
n. 2	Cushioning seal
n. 2	Piston seal
n. 1	Nose seal
n. 2	Linear rubber ring for piston (damper)
n. 2	Tube O-ring
n. 1	Piston guiding ring
n. 4	Adjustment screw O-ring
n. 1	Sempiston O-ring

Standard seal kit code key

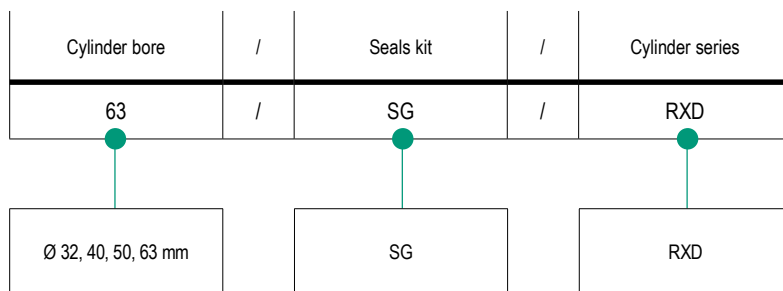

*For cylinders with options P, H1, V, V1 and BT, the kit include further components.

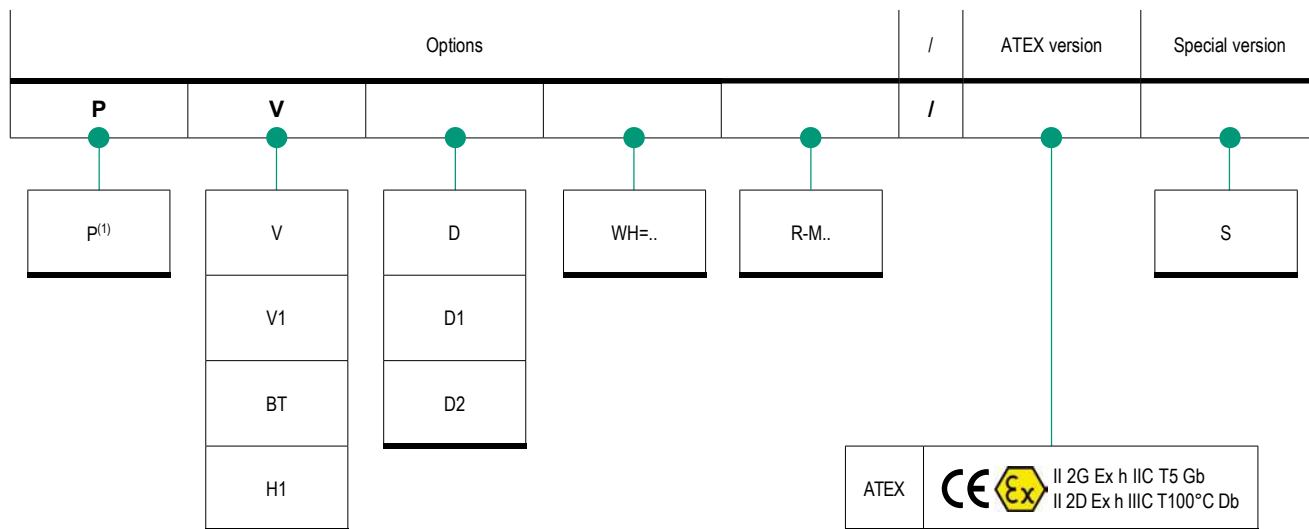

Standard materials

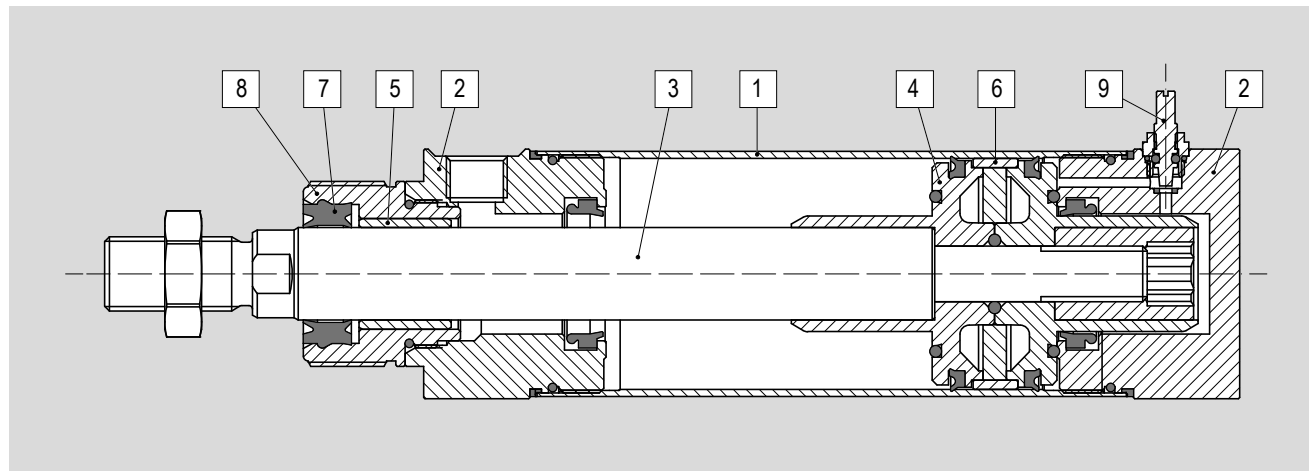

Position	Description	Material
1	Tube	Stainless Steel AISI 316 L
2	Heads	Stainless Steel AISI 316 L
3	Rod	Stainless Steel AISI 316 L lapped
4	Piston	Die-cast aluminium
5	Bushing	Self-lubricated sintered bronze
6	Guide ring	Natural acetatic resin
7	Rod seal	Special polyurethane
8	Disassembling nose	Stainless Steel AISI 316 L
9	Cushioning screw assembly	Stainless Steel AISI 316 L
-	Other seals	NBR / Polyurethane (PU)

Accessories

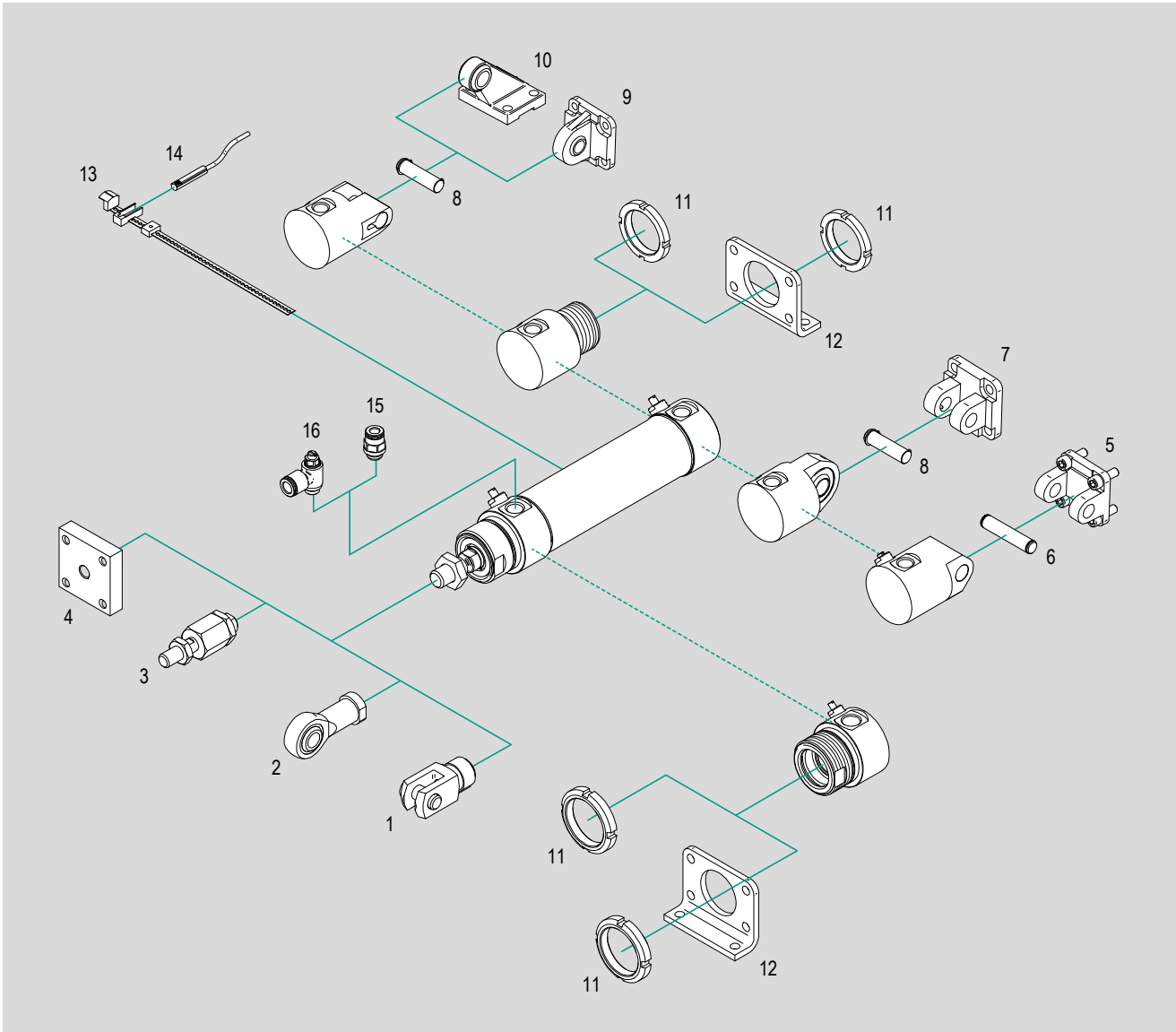

N.	Cylinder bore	Item	Description	Compliance	Cylinder type matching							Code key page	Data sheet page		
					VA	VD	FP	CM	CS	CF	BA			BP	
1	Ø 32 ÷ 63	FFX..ISO	Stainless Steel ISO female clevis with pin and seeger	ISO 8140	●	●	●	●	●	●	●	●	5.11.90	5.52.1	
2	Ø 32 ÷ 63	RFX..SE	Stainless Steel bearing heads (DIN 648K) with female thread	ISO 8139	●	●	●	●	●	●	●	●		5.54.1	
3	Ø 32 ÷ 63	GBX..	Stainless Steel self-aligning articulated coupling	-	●	●	●	●	●	●	●	●		5.55.1	
4	Ø 32 ÷ 63	GCX..	Stainless Steel self-aligning coupling	-	●	●	●	●	●	●	●	●		5.57.1	
5	Ø 32 ÷ 63	CFX..AQIS	Stainless Steel rear clevis	ISO MP2	-	-	-	●	-	-	-	-		5.73.50	
6	Ø 32 ÷ 63	SECX..AQIS	Stainless Steel pin with seeger	AA4	-	-	-	●	-	-	-	-	5.11.91	5.75.5	
7	Ø 32 ÷ 63	CFSX..AQIS	Stainless Steel narrow rear clevis (for DIN 648K bearing)	ISO AB6	-	-	-	-	●	-	-	-	5.11.90	5.73.50	
8	Ø 32 ÷ 63	SECX..ARAQIS	Stainless Steel anti-rotating pin with seeger	AA6	-	-	-	-	●	●	-	-	5.11.91	5.75.5	
9	Ø 32 ÷ 63	CMSX..AQIS	Stainless Steel narrow rear eye with DIN 648K bearing	ISO MP6	-	-	-	-	-	●	-	-	5.11.90	5.73.51	
10	Ø 32 ÷ 63	ASSX..AQIS	Stainless Steel rear 90° hinge with DIN 648K spherical bearing	ISO CS7	-	-	-	-	-	●	-	-		5.73.51	
11	Ø 32 ÷ 63	GHX..AQM	Stainless Steel head nut	-	● ¹	●	-	-	-	-	-	-	5.11.91	5.73.52	
12	Ø 32 ÷ 63	PX..AQM	Stainless Steel foot-flange		●	●	-	-	-	-	-	-		5.73.52	
13	Ø 32 ÷ 63	AFR..	Bracket for magnetic reed switch T groove		●	●	●	●	●	●	●	●		●	1.120.3
14	Ø 32 ÷ 63	ASV..	Magnetic reed switch T groove		2014/34/UE	●	●	●	●	●	●	●		●	1.110.10
		MK..	ATEX magnetic reed switch T groove	●		●	●	●	●	●	●	●	1.113.1		
15	Ø 32 ÷ 63	RX	Stainless steel push-in fittings	-	●	●	●	●	●	●	●	●	5.302.1		
16	Ø 32 ÷ 63	VX..C	Stainless Steel flow controls, for cylinders	-	●	●	●	●	●	●	●	●	5.372.1		

Key

● matching accessory; - not matching accessory

(1) For front end cap only

Stainless Steel round cylinders
Series RXD

Main features

32 ÷ 63

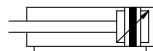

RXD

Bores Ø

Double acting
Magnetic
With cushionings

Series



Technical data

Bore Ø	32	40	50	63
Fluid	Filtered compressed air with or without lubrication. Lubrication, if started, must be continued.			
Pressure range	1 ÷ 10 bar			
Temperature range	-20°C ÷ +80°C (standard)	-20°C ÷ +150°C (V)	-40°C ÷ +80°C (BT)	
Strokes	10 ÷ 1000 mm			
Cushion length	20 mm	22 mm	25 mm	
Ports	1/8"	1/4"		3/8"
Rod thread	M10x1,25	M12x1,25	M16x1,5	

Notes

For dimensions and specific features of each type, see the following pages.
For standard materials see page 5.10.7

Standard strokes

Stroke mm	RXD Bore Ø mm			
	32	40	50	63
25				
50				
80				
100				
125				
160				
200				
250				
320				
400				
500				

Key

□ Standard stroke

Round cylinders series RXD			Compliance	Front end cap	Rear end cap	Data sheet page
RXDVA	Round cylinder with threaded front end cap and flat rear end cap		-			5.11.12
RXDVD	Round cylinder with threaded front and rear end caps		-			5.11.14
RXDVP	Round cylinder with demountable nose on front end cap and flat rear end cap with four female threads		-			5.11.15
RXDVM	Round cylinder with demountable nose on front end cap, and rear eye integrated in the rear end cap					5.11.16
RXDVS	Round cylinder with demountable nose on front end cap, and narrow rear eye integrated in the rear end cap					5.11.17
RXDVF	Round cylinder with demountable nose on front end cap, and narrow rear clevis integrated in the rear end cap					5.11.18
RXDVA	Round cylinder with demountable nose on front end cap with integrated pins, and flat rear end cap		-			5.11.19
RXDVB	Round cylinder with demountable nose on front end cap, and flat rear end cap with integrated pins		-			5.11.20

Stainless Steel round cylinders

Series RXDVA

Version

32 ÷ 63

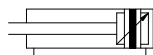

RXDVA



Bores Ø

Double acting
Magnetic
With cushionings

Threaded front
end cap

Flat rear end cap

Type

Peculiar characteristics

The assembly is through the threaded front end cap. The rear end cap is flat, the cylinder body is with no chamfers or cavities where dirt can settle. For the same reason, the adjusting cushioning screws are not recessed but protruding the body of the cylinder.
On this type through rod option (P) is available. For dimensions see page 5.11.10
Stainless steel head nut type GHX..AQM (see page 5.11.91) is compatible with front end cap.

Standard dimensions

Type: **RXDVA**

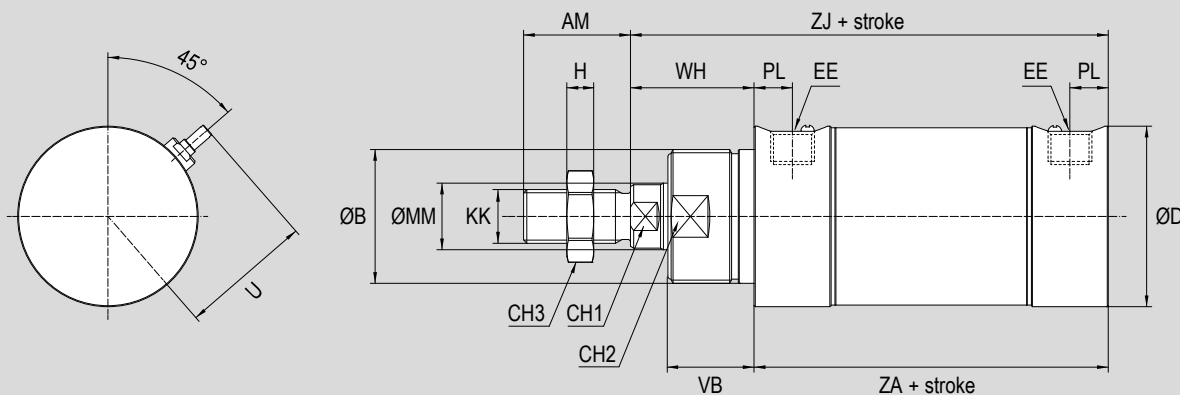

Ø (mm)	AM	ØB	ØD	EE	KK	ØMM f7	PL	VB	U	WH	ZA + stroke	ZJ + stroke	CH1	CH2	CH3	H
32	22	M30x1,5	36	G1/8"	M10x1,25	12	10,5	20	26,5	26	94	120	10	29	17	5
40	24	M38x1,5	45	G1/4"	M12x1,25	16	12	22	31	30	105	135	13	36	19	6
50	32	M45x1,5	54	G1/4"	M16x1,5	20	11,5	26	39,5	37	106	143	17	42	24	8
63	32	M45x1,5	68	G3/8"	M16x1,5	20	14,5	25	38,5	37	121	158	17	42	24	8

Dimensions with option

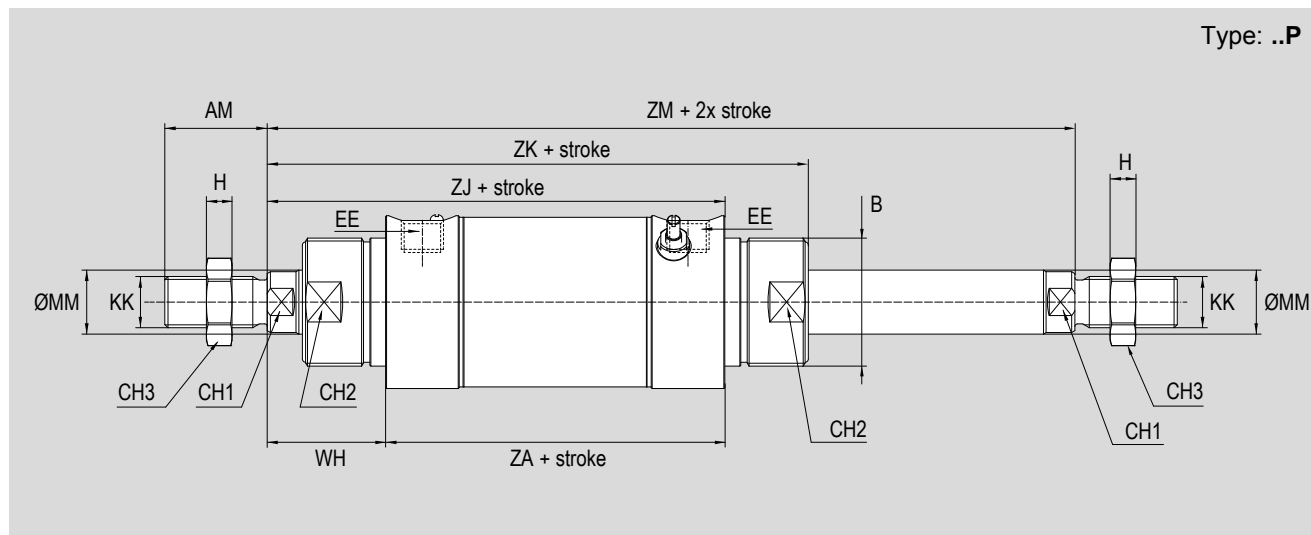

Ø (mm)	AM	B	ØMM f7	WH	ZA + ₀ ⁺¹	ZJ + ₀ ⁺¹	ZK + ₀ ⁺¹	ZM + ₀ ⁺¹	KK	EE	CH1	CH2	CH3	H
32	22	M30x1,5	12	26	94	120	140	146	M10x1,25	G1/8"	10	29	17	5
40	24	M38x1,5	16	30	105	135	157	165	M12x1,25	G1/4"	13	36	19	6
50	32	M45x1,5	20	37	106	143	169	180	M16x1,5	G1/4"	17	42	24	8
63	32	M45x1,5	20	37	121	158	183	195	M16x1,5	G3/8"	17	42	24	8

Stainless Steel round cylinders
Series RXDVD

Version

32 ÷ 63

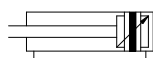

RXDVD

Bores \emptyset

Double acting
Magnetic
With cushionings

Threaded front
end cap

Threaded rear
end cap

Type



Peculiar characteristics

The front and the rear end caps are both threaded for the assembly.
The cylinder body is with no chamfers or cavities where dirt can settle. For the same reason, the adjusting cushioning screws are not recessed but protruding the body of the cylinder.
Stainless steel head nut type GHX..AQM (see page 5.11.91) is compatible with front and rear end caps.

Standard dimensions

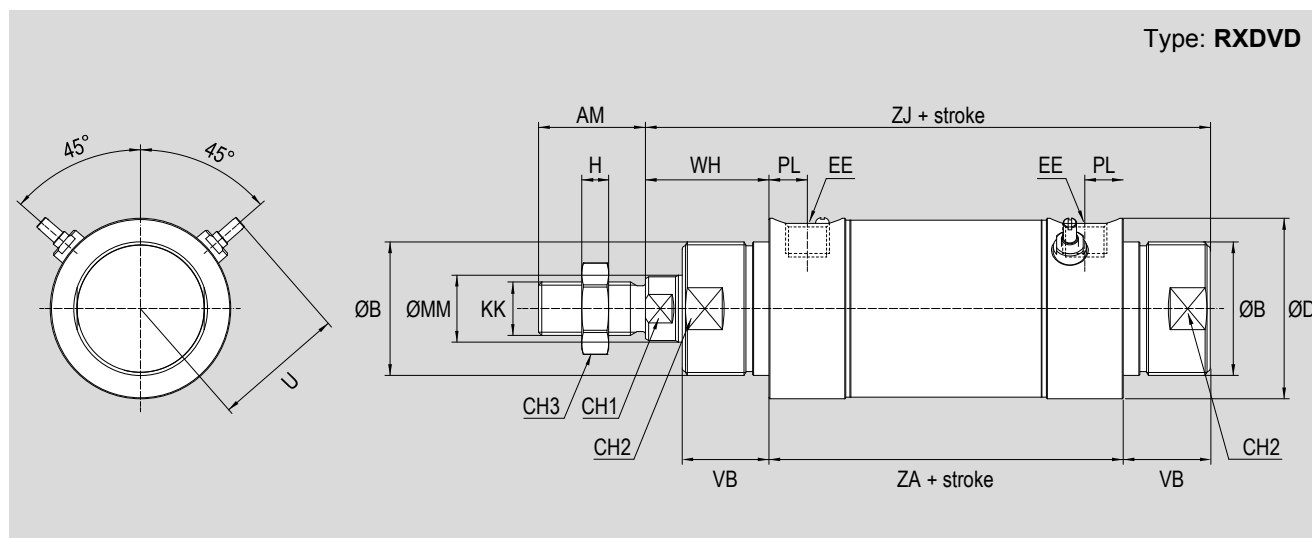

\emptyset (mm)	AM	$\emptyset B$	$\emptyset D$	EE	KK	$\emptyset MM$ f7	PL	VB	U	WH	ZA + $\frac{1}{2}$	ZJ + $\frac{1}{2}$	CH1	CH2	CH3	H
32	22	M30x1,5	36	G1/8"	M10x1,25	12	10,5	20	26,5	26	94	140	10	29	17	5
40	24	M38x1,5	45	G1/4"	M12x1,25	16	12	22	31	30	105	157	13	36	19	6
50	32	M45x1,5	54	G1/4"	M16x1,5	20	11,5	26	39,5	37	106	169	17	42	24	8
63	32	M45x1,5	68	G3/8"	M16x1,5	20	14,5	25	38,5	37	121	183	17	42	24	8

Stainless Steel round cylinders

Series RXDFP

Version

32 ÷ 63

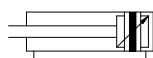

RXDFP

Bores Ø

Double acting
Magnetic
With cushionings

Front end cap with
demountable nose

Flat rear end cap
with threaded holes

Type



Peculiar characteristics

The front end cap is clean design, with no cavities and demountable nose, allowing maintenance directly on the machine where cylinder is assembled, thus reducing maintenance time. The rear end cap is flat with four female threaded holes. The cylinder body is with no chamfers or cavities where dirt can settle. For the same reason, the adjusting cushioning screws are not recessed but protruding the body of the cylinder.

Standard dimensions

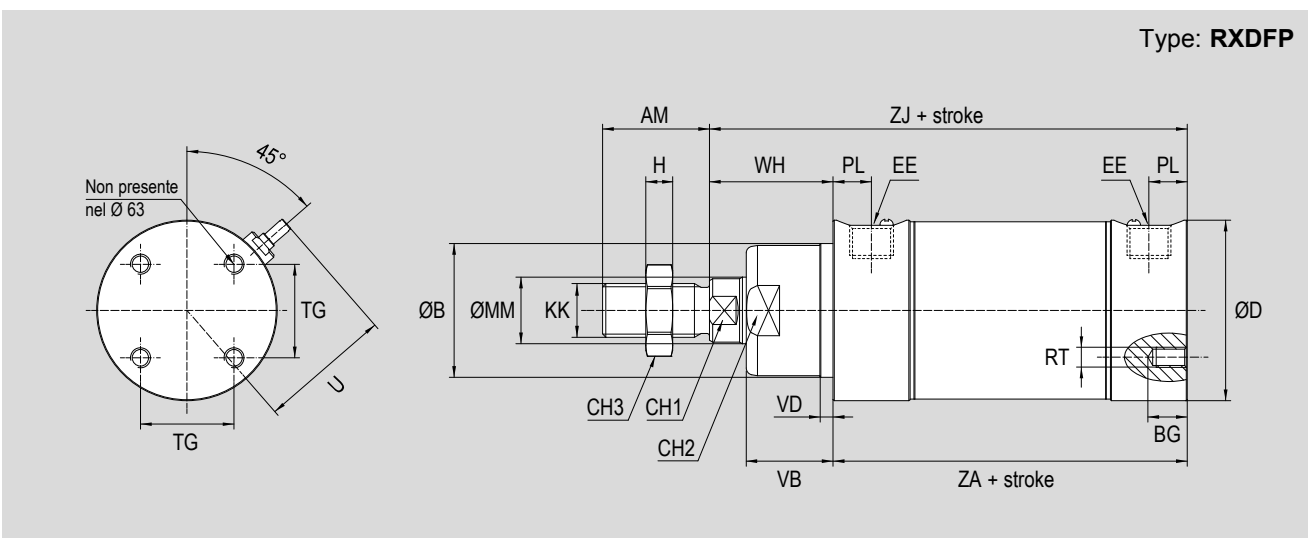

Ø (mm)	AM	ØB d11	BG	ØD	EE	KK	ØMM f7	PL	RT	TG	VB
32	22	30	6	36	G1/8"	M10x1,25	12	10,5	M4	19	20
40	24	35	8	45	G1/4"	M12x1,25	16	12	M5	24	22
50	32	40	9	54	G1/4"	M16x1,5	20	11,5	M6	28	26
63	32	45	12	68	G3/8"	M16x1,5	20	14,5	M8	35	25

Ø (mm)	VD	U	WH	ZA +1 -0	ZJ +1 -0	CH1	CH2	CH3	H
32	4	26,5	26	94	120	10	29	17	5
40	4	31	30	105	135	13	33	19	6
50	4	39,5	37	106	143	17	38	24	8
63	4	38,5	37	121	158	17	42	24	8

5 - STAINLESS STEEL COMPONENTS

Stainless Steel round cylinders

Series RXDCM

Version

32 ÷ 63

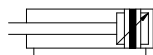

RXDCM

Bores Ø

Double acting
Magnetic
With cushionings

Front end cap with
demountable nose

Rear end cap with
rear eye ISO MP4

Type



Peculiar characteristics

The front end cap is clean design, with no cavities and demountable nose, allowing maintenance directly on the machine where cylinder is assembled, thus reducing maintenance time. A rear eye conforming to ISO MP4 standards is integrated in the rear end cap, this way the dimensions of the cylinder are compliant with ISO 15552 standards. The stainless steel rear female clevis ISO MP2 type CFX..AQIS (see page 5.11.50) can be mounted to the integrated rear eye with the stainless steel pin type SECX..AQIS. The cylinder body is with no chamfers or cavities where dirt can settle. For the same reason, the adjusting cushioning screws are not recessed but protruding the body of the cylinder.

Standard dimensions

Type: **RXDCM**

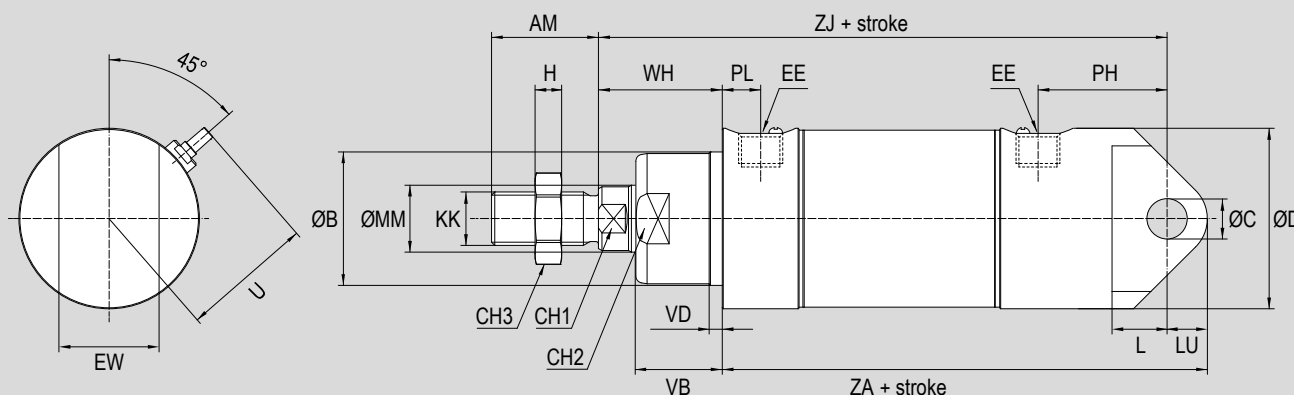

Ø (mm)	AM	ØB d11	ØC H8	ØD	EE	EW	KK	ØMM f7	L	LU	PH
32	22	30	10	36	G1/8"	26	M10x1,25	12	13	9	32,5
40	24	35	12	45	G1/4"	28	M12x1,25	16	16	10	37
50	32	40	12	54	G1/4"	32	M16x1,5	20	16,5	12	37
63	32	45	16	68	G3/8"	40	M16x1,5	20	21	12	46

Ø (mm)	PL	VB	VD	U	WH	ZA ± 0	ZJ ± 0	CH1	CH2	CH3	H
32	10,5	20	4	26,5	26	125	142	10	29	17	5
40	12	22	4	31	30	140	160	13	33	19	6
50	11,5	26	4	39,5	37	145	170	17	38	24	8
63	14,5	25	4	38,5	37	165	190	17	42	24	8

5.11.16

Stainless Steel round cylinders

Series RXDCS

Version

32 ÷ 63

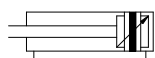

RXDCS

Bores \emptyset

Double acting
Magnetic
With cushionings

Front end cap with
demountable nose

Rear end cap with
narrow rear eye
ISO MP6

Type



Peculiar characteristics

The front end cap is clean design, with no cavities and demountable nose, allowing maintenance directly on the machine where cylinder is assembled, thus reducing maintenance time. A narrow rear eye with DIN 648K spherical bearing according to ISO MP6 standards is integrated in the rear end cap, this way the dimensions of the cylinder are compliant with ISO 15552 standards. The stainless steel narrow rear clevis ISO AB6 type CFSX.AQIS (see page 5.11.50) can be mounted to the integrated narrow rear eye with the stainless steel anti-rotating pin type SECX.ARAQIS. The cylinder body is with no chamfers or cavities where dirt can settle. For the same reason, the adjusting cushioning screws are not recessed but protruding the body of the cylinder.

Standard dimensions

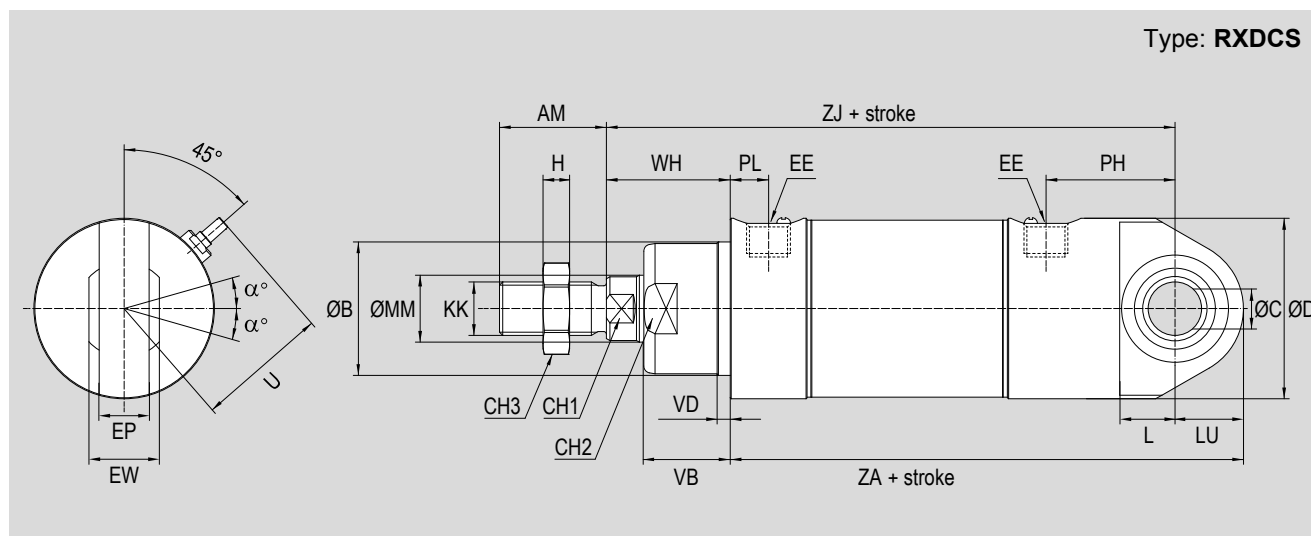

\emptyset (mm)	AM	$\emptyset B$ d11	$\emptyset C$ H8	$\emptyset D$	EE	EP	EW	KK	$\emptyset MM$ f7	L	LU	PH
32	22	30	10	36	G1/8"	10,5	14	M10x1,25	12	13	15	32,5
40	24	35	12	45	G1/4"	12	16	M12x1,25	16	16	19	37
50	32	40	16	54	G1/4"	15	21	M16x1,5	20	16,5	20,5	38,5
63	32	45	16	68	G3/8"	15	21	M16x1,5	20	21	24	46,5

\emptyset (mm)	PL	VB	VD	U	WH	ZA + stroke	ZJ + stroke	CH1	CH2	CH3	H	α°
32	10,5	20	4	26,5	26	131	142	10	29	17	5	13
40	12	22	4	31	30	149	160	13	33	19	6	13
50	11,5	26	4	39,5	37	153,5	170	17	38	24	8	15
63	14,5	25	4	38,5	37	177	190	17	42	24	8	15

5 - STAINLESS STEEL COMPONENTS

Stainless Steel round cylinders

Series RXDCF

Version

32 ÷ 63

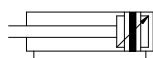

RXDCF

Bores \emptyset

Double acting
Magnetic
With cushionings

Front end cap with
demountable nose

Rear end cap with
narrow rear clevis
ISO AB6

Type



Peculiar characteristics

The front end cap is clean design, with no cavities and demountable nose, allowing maintenance directly on the machine where cylinder is assembled, thus reducing maintenance time. A narrow rear clevis according to ISO AB6 standards is integrated on the rear end cap, this way the dimensions of the cylinder are compliant with ISO 15552 standards. The stainless steel narrow rear eye ISO MP6 (with spherical bearing DIN 648K) type CMSX..AQIS or the stainless steel rear 90° hinge ISO CS7 with DIN 648K spherical bearing type ASSX..AQIS (see page 5.11.50) can be mounted to the integrated narrow rear clevis with the stainless steel anti-rotating pin type SECX..ARAQIS. The cylinder body is with no chamfers or cavities where dirt can settle. For the same reason, the adjusting cushioning screws are not recessed but protruding the body of the cylinder.

Standard dimensions

Type: RXDCF

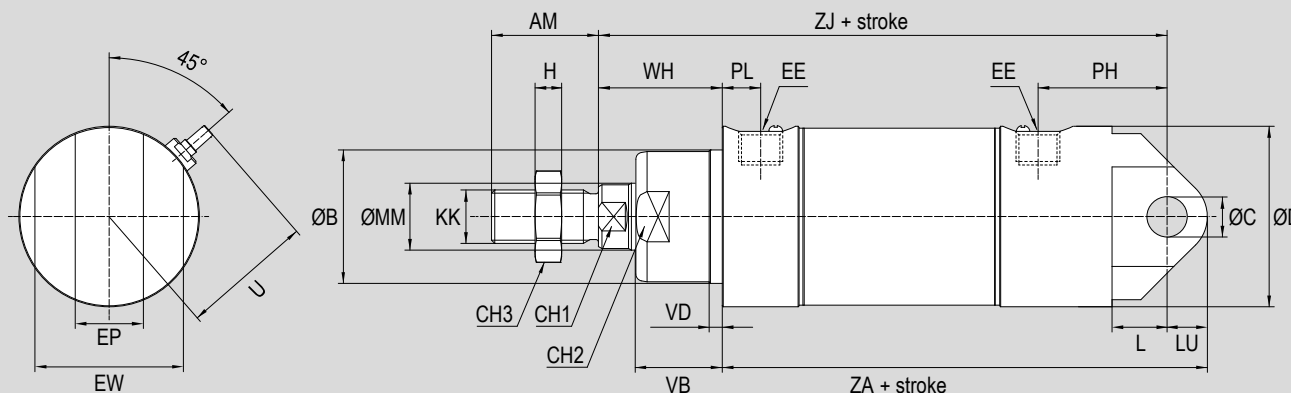

\emptyset (mm)	AM	$\emptyset B$ d11	$\emptyset C$ H8	$\emptyset D$	EE	EP	EW	KK	$\emptyset MM$ f7	L	LU	PH
32	22	30	10	36	G1/8"	14	34	M10x1,25	12	16	9	32,5
40	24	35	12	45	G1/4"	16	40	M12x1,25	16	19	10	37
50	32	40	16	54	G1/4"	21	45	M16x1,5	20	21	12	37
63	32	45	16	68	G3/8"	21	51	M16x1,5	20	24	12	46

\emptyset (mm)	PL	VB	VD	U	WH	ZA + ₀	ZJ + ₀	CH1	CH2	CH3	H
32	10,5	20	4	26,5	26	125	142	10	29	17	5
40	12	22	4	31	30	140	160	13	33	19	6
50	11,5	26	4	39,5	37	145	170	17	38	24	8
63	14,5	25	4	38,5	37	165	190	17	42	24	8

Stainless Steel round cylinders
Series RXDBA

Version

32 ÷ 63

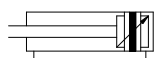

RXDBA

Bores Ø

Double acting
Magnetic
With cushionings

Front end cap
with pins

Flat rear end cap

Type



Peculiar characteristics

The front end cap is clean design, with no cavities and demountable nose, allowing maintenance directly on the machine where cylinder is assembled, thus reducing maintenance time. Two pins are integrated in the front end cap, thus allow mounting to supports, and provide an oscillatory movement. The rear end cap is flat, the cylinder body is with no chamfers or cavities where dirt can settle. For the same reason, the adjusting cushioning screws are not recessed but protruding the body of the cylinder.

Standard dimensions

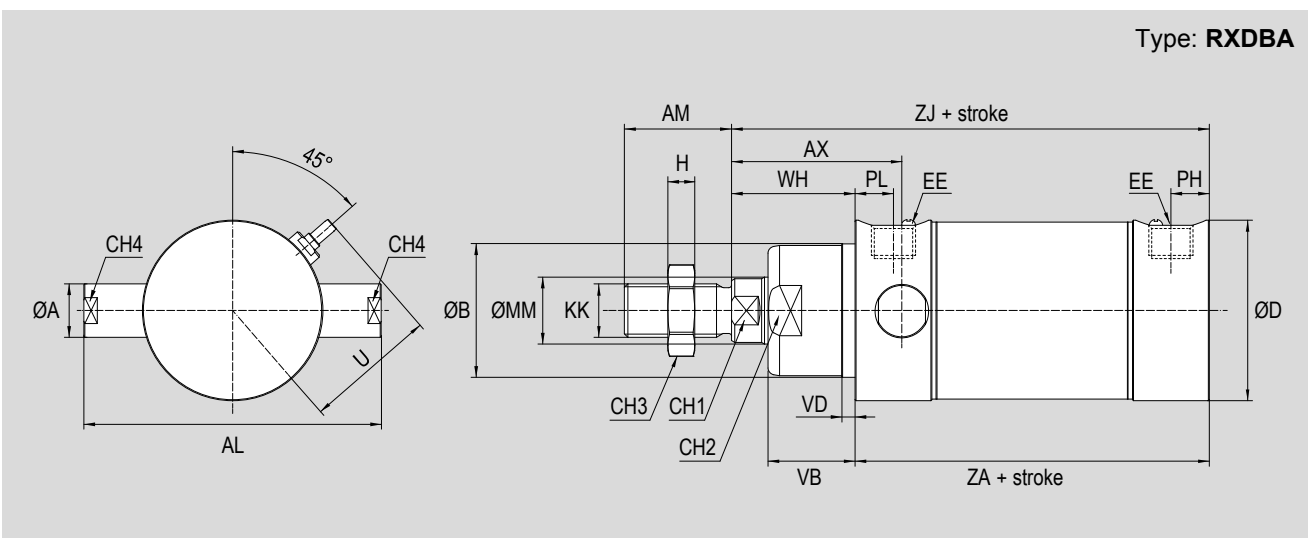

Ø (mm)	ØA f7	AL	AX	AM	ØB d11	ØD	EE	KK	ØMM f7	PL	VB
32	12	67	39	22	30	36	G1/8"	M10x1,25	12	10,5	20
40	12	76	43	24	35	45	G1/4"	M12x1,25	16	12	22
50	16	89	40	32	51	54	G1/4"	M16x1,5	20	11,5	26
63	16	103	47	32	47	68	G3/8"	M16x1,5	20	14,5	25

Ø (mm)	VD	U	WH	ZA + ₀	ZJ + ₀	CH1	CH2	CH3	CH4	H
32	4	26,5	26	94	120	10	29	17	10	5
40	4	31	30	105	135	13	33	19	10	6
50	4	39,5	37	106	143	17	38	24	14	8
63	4	38,5	37	121	158	17	42	24	14	8

5 - STAINLESS STEEL COMPONENTS

Stainless Steel round cylinders

Series RXDBP

Version

32 ÷ 63

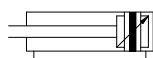

RXDBP

Bores \emptyset

Double acting
Magnetic
With cushionings

Front end cap with
demountable nose

Flat rear end cap
with pins

Type



Peculiar characteristics

The front end cap is clean design, with no cavities and demountable nose, allowing maintenance directly on the machine where cylinder is assembled, thus reducing maintenance time. Two pins are integrated in the flat rear end cap, thus allow mounting to supports, and provide an oscillatory movement.
The cylinder body is with no chamfers or cavities where dirt can settle. For the same reason, the adjusting cushioning screws are not recessed but protruding the body of the cylinder.

Standard dimensions

Type: **RXDBP**

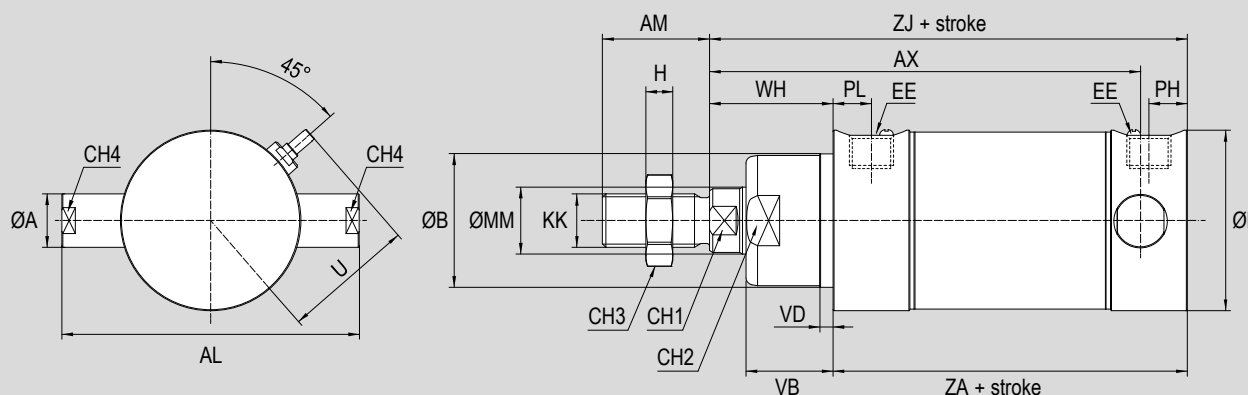

\emptyset (mm)	$\emptyset A$ f7	AL	AX	AM	$\emptyset B$ d11	$\emptyset D$	EE	KK	$\emptyset MM$ f7	PL	VB
32	12	67	110	22	30	36	G1/8"	M10x1,25	12	10,5	20
40	12	76	122	24	35	45	G1/4"	M12x1,25	16	12	22
50	16	89	129	32	40	54	G1/4"	M16x1,5	20	11,5	26
63	16	103	148	32	45	68	G3/8"	M16x1,5	20	14,5	25

\emptyset (mm)	VD	U	WH	ZA + stroke	ZJ + stroke	CH1	CH2	CH3	CH4	H
32	4	26,5	26	94	120	10	29	17	10	5
40	4	31	30	105	135	13	33	19	10	6
50	4	39,5	37	106	143	17	38	24	14	8
63	4	38,5	37	121	158	17	42	24	14	8

Accessories for stainless steel round cylinders
Series RXD

Stainless Steel female clevis with pin and seeger FFX..ISO

	For cylinder Ø mm	Code	Item	Compliance
	32	041055	FFX10ISO	
	40	041056	FFX12ISO	
	50-63	041057	FFX16ISO	

Stainless Steel bearing heads (DIN 648K) RFX..SE

	For cylinder Ø mm	Code	Item	Compliance
	32	040009	RFX10SE	
	40	041578	RFX12SE	
	50-63	040011	RFX16SE	

Stainless Steel self-aligning articulated coupling GBX..

	For cylinder Ø mm	Code	Item	Compliance
	32	041737	GBX040	-
	40	041738	GBX060	
	50-63	041739	GBX100	

Stainless Steel self-aligning coupling GCX..

	For cylinder Ø mm	Code	Item	Compliance
	32	041728	GCXM10x1,25	-
	40	041729	GCXM12x1,25	
	50-63	041730	GCXM16x1,5	

Stainless Steel rear clevis* CFX..AQIS

	For cylinder Ø mm	Code	Item	Compliance
	32	040012	CFX032AQIS	
	40	040830	CFX040AQIS	
	50	040801	CFX050AQIS	
	63	040014	CFX063AQIS	

*Matching only with type RXDCM.
Pin type SECX..AQIS to be ordered separately, see page 5.11.91

Stainless Steel narrow rear clevis* (for DIN 648K bearing) CFSX..AQIS

	For cylinder Ø mm	Code	Item	Compliance
	32	040821	CFSX032AQIS	
	40	040822	CFSX040AQIS	
	50	040823	CFSX050AQIS	
	63	040824	CFSX063AQIS	

*Matching only with type RXDCS.
Anti-rotating pin type SECX..ARAQIS to be ordered separately, see page 5.11.91

Stainless Steel narrow rear eye* with DIN 648K bearing CMSX..AQIS

	For cylinder Ø mm	Code	Item	Compliance
	32	040834	CMSX032AQIS	
	40	040835	CMSX040AQIS	
	50	040836	CMSX050AQIS	
	63	040010	CMSX063AQIS	

*Matching only with type RXDCF.
Anti-rotating pin type SECX..ARAQIS to be ordered separately, see page 5.11.91

Stainless Steel rear 90°hinge* with DIN 648K spherical bearing ASSX..AQIS

	For cylinder Ø mm	Code	Item	Compliance
	32	040850	ASSX032AQIS	
	40	040851	ASSX040AQIS	
	50	040852	ASSX050AQIS	
	63	040853	ASSX063AQIS	

*Matching only with type RXDCF.
Anti-rotating pin type SECX..ARAQIS to be ordered separately, see page 5.11.91

Accessories for stainless steel round cylinders

Series RXD

Stainless Steel pin with seeger* SECX..AQIS

	For cylinder Ø mm	Code	Item	Compliance
	32	040829	SECX032AQIS	
	40	040831	SECX040AQIS	
	50	040811	SECX050AQIS	
	63	040832	SECX063AQIS	

*Supplied with 2 seeger

Stainless Steel anti-rotating pin with seeger* SECX..ARAQIS

	For cylinder Ø mm	Code	Item	Compliance
	32	040857	SECX032ARAQIS	
	40	040858	SECX040ARAQIS	
	50	040859	SECX050ARAQIS	
	63	040860	SECX063ARAQIS	

*Supplied with 1 seeger

Stainless Steel foot-flange* PX..AQM

	For cylinder Ø mm	Code	Item	Compliance
	32	040119	PX032AQM	-
	40	040120	PX040AQM	
	50	040137	PX050AQM	
	63	040138	PX063AQM	

*Matching only with type RXDVA and type RXDVD; for mounting require stainless steel head nut type GH..AQM, see alongside.

Stainless Steel head nut* GHX..AQM

	For cylinder Ø mm	Code	Item	Compliance
	32	040069	GHX032AQM	-
	40	040187	GHX040AQM	
	50-63	040188	GHX050/063AQM	

*Matching only with type RXDVA and type RXDVD.

Magnetic reed switch T groove ASV..

	For cylinder Ø mm	Code	Item	Cylinder matching
	32 ÷ 63	070946	ASV1C525	RXD*
		071863	ASV1C550	
		071864	ASV1C51K	
		071189	ASV1C5M8	
		073639	ASV4D225	
		070246	ASV4D2M8	
		074900	ASV7N225	
		070247	ASV7N2M8	
		070372	ASV7M2M8	
		072918	ASV1H525	

*With bracket type AFR1063 for magnetic reed switches T groove

ATEX magnetic reed switch T groove MK..

	For cylinder Ø mm	Code	Item	Compliance	Cylinder matching
	32 ÷ 63	071120	MK500A		RXD*
		071108	MK502A		

*With bracket type AFR1063 for magnetic reed switches T groove

Bracket for magnetic reed switch T groove type AFR..

	For cylinder Ø mm	Code	Item	Compliance
	32 ÷ 63	072907	AFR1063	-