

STC Series

1.5 Bellows Suction Cup Special for Sheet Metal



Features

- ◇ Large inner support structure protects the metal sheets from deformation and damage during handling process.
- ◇ Slot structure efficiently increases the friction force between vacuum pad and workpiece in order to prevent the oily metal sheets from slipping during the handling process.
- ◇ 1.5 Bellows structure has good sealing and buffer to workpiece with uneven surface

Applications

- ◇ Car stamped steel plate with irregular shapes, oily steel plate.
- ◇ Glass, stamping parts, plywood
- ◇ Handling normal sheet metal (to avoid deformation)

How to order

STC 22 N - G2F

① ② ③ ④

① Series	② Diameter	③ Material & Hardness	④ Connection thread
STC	22 - φ22mm	N - NBR 60	G2F - G1/4 Female thread G2M - G1/4 Male thread G3F - G3/8 Female thread M10M - M10 Male thread M14M - M14×1.5 Male thread RA - Rectangular adapter
	30 - φ30mm		
	40 - φ40mm		
	50 - φ50mm		
	60 - φ60mm		
	80 - φ80mm		
	100- φ100mm		
	125- φ125mm		

STC Series

1.5 Bellows Suction Cup Special for Sheet Metal

Selection

Model/ Connection thread	G2M	G2F	G3F	M10M	M14M	RA
STC22 - 40	○	●	—	○	○	○
STC50 - 125	○	—	●	○	○	○

◇Note: "●"- standard, in stock. "○"-selective,no stock."—"-unavailable.

Technical parameters

Model	Vertical pull-out force (N)	Lateral pull-out force (N)	Lateral pull-out force N(oily surface)	Inner volume (cm ³)	Min. curve radius of workpiece (mm)	Recommended hose dia. (mm)	Weight (g)
STC22	23	20	6.5	1.5	20	6	8.6
STC30	35	28	12	6.3	35	6	12
STC40	62	37	34	7.2	40	6	13.5
STC50	85	58	55	11.2	45	8	21
STC60	141	88	83	22.5	52	8	29
STC80	236	141	136	57	70.5	8	51
STC100	371	228	221	92	95	8	77
STC125	558	352	335	191	140	10	165

◇Note: Testing vacuum level -60kPa.Workpiece with smooth and clean surface. The data of pull-out force as above are figured out without considering safety factor. The data may be different according to different workpiece surfaces.

- SB
- SBA
- SBB
- SBF
- SBOF
- SFT
- STP
- SBL
- SBLP
- SF
- SU
- SUF
- SFG
- STC**
- SFF
- SFM
- SDM
- SOB
- SOF
- SOG
- SFP
- SBP
- SXP
- SGP
- SDL
- SH
- SHB
- SZ
- SAN
- SAO
- SPA
- SPC
- SPF
- SPJ
- SPU
- SNP
- SOP

STC Series

1.5 Bellows Suction Cup Special for Sheet Metal

Dimensions (mm)

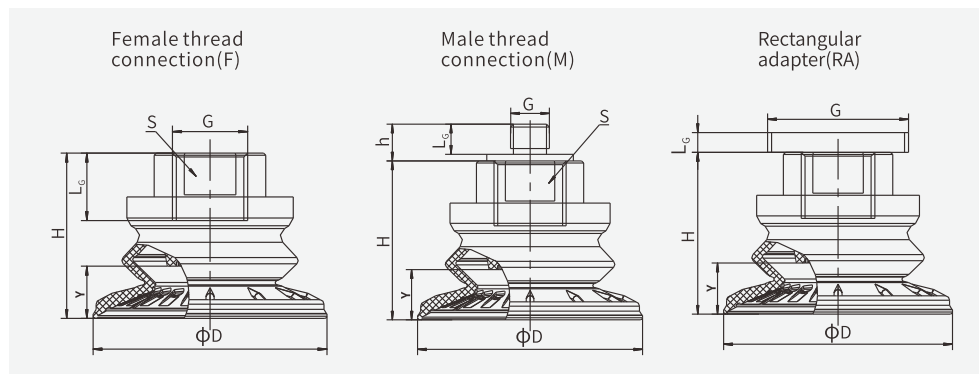

Model/ Size	D	H	G	L _c	h	S	Y
STC22-G2M	22	25	G1/4	12	13.5	16	5.5
G2F			G1/4	11	—	16	
M10M			M10	12	13.5	16	
M14M			M14×1.5	12	13.5	16	
RA			□32	4.7	—	—	
STC30-G2M	32	28	G1/4	12	13.5	17	9.5
G2F			G1/4	11	—	17	
M10M			M10	12	13.5	17	
M14M			M14×1.5	12	13.5	16	
RA			□32	4.7	—	—	
STC40-G2M	42	28.5	G1/4	12	13.5	17	10
G2F			G1/4	11	—	17	
M10M			M10	12	13.5	17	
M14M			M14×1.5	12	13.5	17	
RA			□32	4.7	—	—	
STC50-G2M	52	37	G1/4	12	13.5	22	11.5
G3F			G3/8	13	—	22	
M10M			M10	12	13.5	22	
M14M			M14×1.5	12	13.5	22	
RA			□32	4.7	—	—	
STC60-G2M	62.5	41	G1/4	12	13.5	22	14.5
G3F			G3/8	13	—	22	
M10M			M10	12	13.5	22	
M14M			M14×1.5	12	13.5	22	
RA			□32	4.7	—	—	
STC80-G2M	82	50.5	G1/4	12	13.5	22	22.5
G3F			G3/8	13	—	22	
M10M			M10	12	13.5	22	
M14M			M14×1.5	12	13.5	22	
RA			□32	4.7	—	—	
STC100-G2M	102.5	56	G1/4	12	13.5	22	25
G3F			G3/8	13	—	22	
M10M			M10	12	13.5	22	
M14M			M14×1.5	12	13.5	22	
RA			□32	4.7	—	—	
STC125-G2M	128	68	G1/4	12	13.5	22	32
G3F			G3/8	13	—	22	
M10M			M10	12	13.5	22	
M14M			M14×1.5	12	13.5	22	
RA			□32	4.7	—	—	