

Flow controls

Flow controls for cylinders

Version	Symbol	Type
Body and banjo bolt with adjustment (in brass)		
Banjo bolt with screwdriver adjustment		V15
Banjo bolt with manual adjustment		V14
Banjo BSP with screwdriver adjustment		V17
Banjo BSP with manual adjustment		V40
Swivel with screwdriver adjustment and push-in fitting		V18
Swivel with manual adjustment and push-in fitting		V41
Swivel with screwdriver adjustment and rapid fitting		V20
Body in Delrin and banjo bolt with adjustment in brass		
Banjo with screwdriver adjustment and push-in fitting		V39
Banjo with manual adjustment and push-in fitting		V37
Swivel with screwdriver adjustment and push-in fitting		V38
Swivel with manual adjustment and push-in fitting		V36



Series of flow controls normally applied directly to cylinder connections to control the translation velocity. Available with different functions: unidirectional with outlet adjustment (C); unidirectional with inlet adjustment (V); bi-directional with adjustment in both directions. In order to control the cylinder velocity it is advisable to apply 2 unidirectional flow controls with outlet adjustment (C), which act on the exhaust flow from the cylinder chambers and don't interfere with the inlet flow to the chambers.

* How to order: V180618C

V18	06	18	C
Type	Tube or thread code	Thread code	Function code

* For standard items, codes and dimensions see tables from page 4.80.12.

For flows see diagrams at page 4.80.30.

External tube Ø (mm)	4	6	8	10	12	14
Code	04	06	08	10	12	14
Threads	M5	1/8"	1/4"	3/8"	1/2"	
Code	M5	18	14	38	12	
Function	For cylinder	For valve	Bi-directional			
Code	C	V	B			

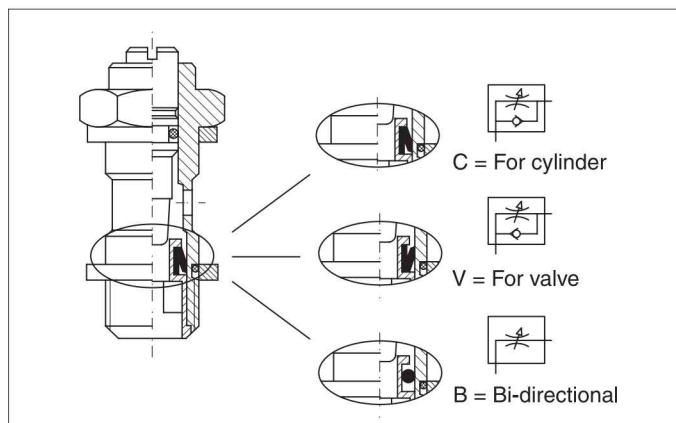

Technical data	
Fluid	Compressed filtered air with or without lubrication
Pressure range	0,5 ÷ 10 bar
Temperature range	-20 °C ÷ +70 °C
Threads	Parallel UNI - ISO 228/1 (BSP) - Metric: ISO R / 262
Connection tubes	Calibrated nylon, polyurethane and rilsan
Tubes tolerances	± 0,05 mm
Materials	Banjo bolt with adjustment: Nickel plated brass Body: Nickel plated brass / Acetal resin Seals: Nitrile rubber (NBR)

Flow controls
Flow controls for cylinders

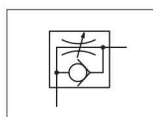
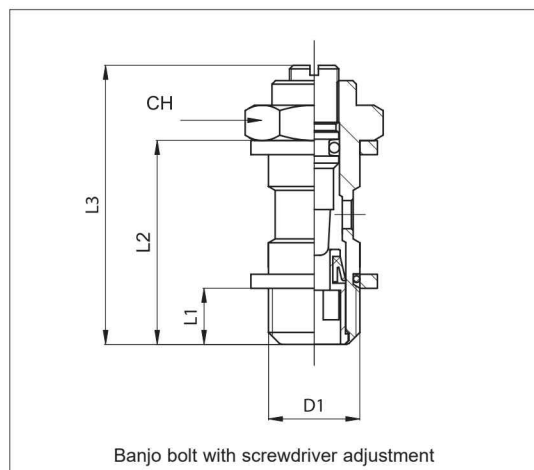

For cylinder

Code	Item	D ₁	L ₁	L ₂	L ₃ max	CH	gr.
024021	V15 00 M5C	M5	4	16	23,5	8	5
024022	V15 00 18C	1/8"	6	25	36	14	16
024023	V15 00 14C	1/4"	8	29	42	17	32
024024	V15 00 38C	3/8"	9	33	52	20	59
024025	V15 00 12C	1/2"	10	39	61	26	108
024090	V15 00 -----	1/2"	10	39	61	26	108

For banjo push-in fittings series R
For banjo push-in fittings series RT
For banjo rapid fittings series C
For banjo compression fittings series O
For banjo standard fittings series A

see page 4.2.9.
see page 4.5.7.
see from page 4.20.7.
see page 4.25.5.
see page 4.35.9.

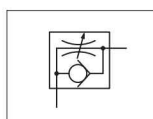
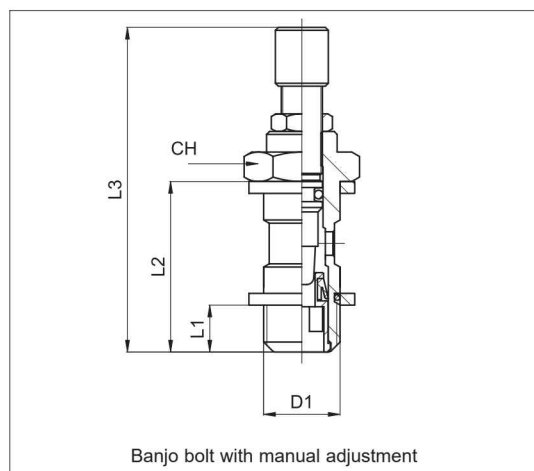

For cylinder

Code	Item	D ₁	L ₁	L ₂	L ₃ max	CH	gr.
024026	V14 00 M5C	M5	4	16	38,5	8	7
024027	V14 00 18C	1/8"	6	25	50	14	22
024028	V14 00 14C	1/4"	8	29	58	17	38
024029	V14 00 38C	3/8"	9	33	72	20	67
024030	V14 00 12C	1/2"	10	39	81	26	121

For banjo push-in fittings series R
For banjo push-in fittings series RT
For banjo rapid fittings series C
For banjo compression fittings series O
For banjo standard fittings series A

see page 4.2.9.
see page 4.5.7.
see from page 4.20.7.
see page 4.25.5.
see page 4.35.9.

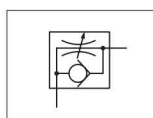
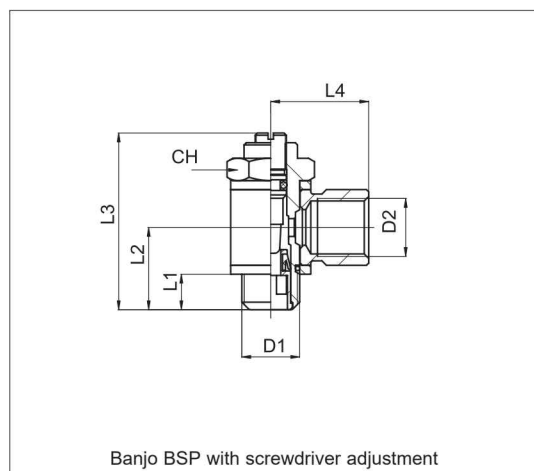

For cylinder

Code	Item	D ₁	D ₂	L ₁	L ₂	L ₃ max	L ₄	CH	gr.
024061	V17 00 M5C	M5	M5	4	11	23,5	11	8	12
024062	V17 00 18C	1/8"	1/8"	6	16	36	17	14	34
024063	V17 00 14C	1/4"	1/4"	8	19	42	22	17	62
024064	V17 00 38C	3/8"	3/8"	9	22	52	26	20	98
024065	V17 00 12C	1/2"	1/2"	10	25	61	32	26	176

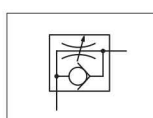
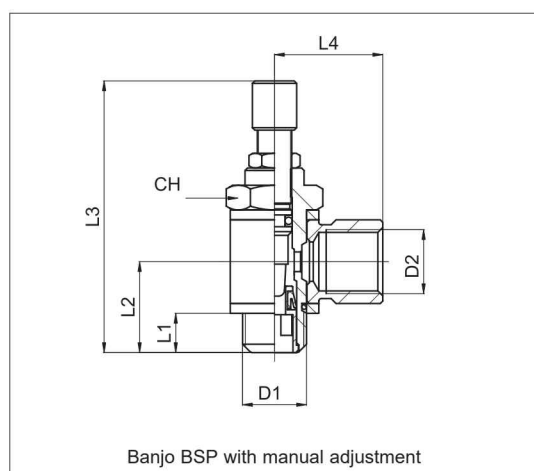

For cylinder

Code	Item	D ₁	D ₂	L ₁	L ₂	L ₃ max	L ₄	CH	gr.
024045	V40 00 M5C	M5	M5	4	11	38,5	11	8	14
024046	V40 00 18C	1/8"	1/8"	6	16	50	17	14	40
024047	V40 00 14C	1/4"	1/4"	8	19	58	22	17	68
024048	V40 00 38C	3/8"	3/8"	9	22	72	26	20	106
024049	V40 00 12C	1/2"	1/2"	10	25	81	32	26	189

Flow controls
Flow controls for cylinders

Swivel with screwdriver adjustment and push-in fitting

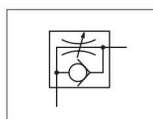

For cylinder

Code	Item	Tube Ø	D ₁	D ₂	D ₃	L ₁	L ₂	L ₃ max	L ₄	CH	gr.
024081	V18 04 M5C	4	M5	9	10	4	11,5	25,5	18	6	12
024082	V18 04 18C	4	1/8"	9	14	5	15	32	24	9	29
024085	V18 06 18C	6	1/8"	12	14	5	15	32	26	9	27
024086	V18 06 14C	6	1/4"	12	18	6,5	18	40	24	10	49
024087	V18 08 18C	8	1/8"	14	14	5	15	32	24	9	31
024088	V18 08 14C	8	1/4"	14	18	6,5	18	40	24	10	49
020246	V18 08 38C	8	3/8"	14	22	9	22	50	26	14	89
024089	V18 10 14C	10	1/4"	16	18	6,5	18	40	30	10	53
024090	V18 10 38C	10	3/8"	16	22	9	22	50	28	14	86

Swivel with manual adjustment and push-in fitting

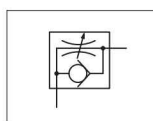

For cylinder

Code	Item	Tube Ø	D ₁	D ₂	D ₃	L ₁	L ₂	L ₃ max	L ₄	CH	gr.
024185	V41 04 M5C	4	M5	10	10	4	11,5	39	24	6	15
024186	V41 04 18C	4	1/8"	10	14	5	15	50	24	9	37
024189	V41 06 18C	6	1/8"	13	14	5	15	50	26	9	41
024190	V41 06 14C	6	1/4"	13	18	6,5	18	58	28	10	63
024191	V41 08 18C	8	1/8"	15	14	5	15	50	28	9	45
024192	V41 08 14C	8	1/4"	15	18	6,5	18	58	28	10	62
024194	V41 08 38C	8	3/8"	14	22	9	22	50	26	14	89
024193	V41 10 14C	10	1/4"	18	18	6,5	18	58	32	10	93
024195	V41 19 38C	10	3/8"	16	22	9	22	63	28	14	105

Swivel with screwdriver adjustment and rapid fitting

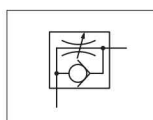

For cylinder

Code	Item	Tube Ø	D ₁	D ₂	L ₁	L ₂	L ₃ max	L ₄	CH ₁	CH ₂	gr.
024141	V20 04 M5C	4-2,5	M5	10	4	11,5	28	15,5	6	7	12
024144	V20 06 M5C	6-4	M5	10	4	11,5	28	19	6	9	12
024145	V20 06 18C	6-4	1/8"	14	5	15	36	25	9	12	40
024146	V20 06 14C	6-4	1/4"	18	6,5	18	42	26,5	10	12	53
024147	V20 08 18C	8-6	1/8"	14	5	15	36	25	9	14	42
024148	V20 08 14C	8-6	1/4"	18	6,5	18	42	27,5	10	14	68
024160	V20 08 38C	8-6	3/8"	22	9	22	50	29,5	14	12	90
024149	V20 10 14C	10-8	1/4"	18	6,5	18	42	28,5	10	16	57
024149	V20 10 38C	10-8	3/8"	22	9	22	50	30,5	14	16	92

Banjo with screwdriver adjustment and push-in fitting (Delrin)

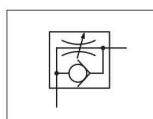

For cylinder

Code	Item	Tube Ø	D ₁	D ₂	L ₁	L ₂	L ₃ max	L ₄	CH	gr.
024100	V39 04 M5C	4	M5	9,7	6	11	23,5	17	8	7
024101	V39 04 18C	4	1/8"	9,7	7	16	36	18,5	14	20
024109	V39 06 M5C	6	M5	12	6	11	23,5	20,5	8	8
024103	V39 06 18C	6	1/8"	12	7	16	36	22	14	22
024104	V39 06 14C	6	1/4"	12	9	19	42	23,5	17	38
024105	V39 08 18C	8	1/8"	14	7	16	36	22,5	14	22
024106	V39 08 14C	8	1/4"	14	9	19	42	24	17	39
024110	V39 08 38C	8	3/8"	14	10	22	52	26	20	67
024107	V39 10 14C	10	1/4"	16,5	9	19	42	26	17	39
024108	V39 10 38C	10	3/8"	16,5	10	22	52	28	20	68

Flow controls
Flow controls for cylinders

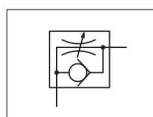
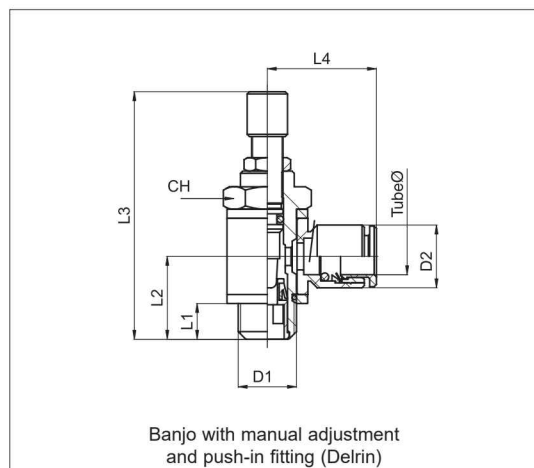

For cylinder

Code	Item	Tube Ø	D ₁	D ₂	L ₁	L ₂	L ₃ max	L ₄	CH	gr.
024311	V37 04 M5C	4	M5	9,7	4	11	38,5	17	8	9
024312	V37 04 18C	4	1/8"	9,7	6	16	50	18,5	14	23
024313	V37 06 M5C	6	M5	12	4	11	38,5	20,5	8	10
024314	V37 06 18C	6	1/8"	12	6	16	50	22	14	25
024315	V37 06 14C	6	1/4"	12	8	19	58	23,5	17	41
024316	V37 08 18C	8	1/8"	14	6	16	50	22,5	14	25
024317	V37 08 14C	8	1/4"	14	8	19	58	24	17	42
024318	V37 08 38C	8	3/8"	14	9	22	72	26	20	70
024319	V37 10 14C	10	1/4"	16,5	8	19	58	26	17	42
024320	V37 10 38C	10	3/8"	16,5	9	22	72	28	20	71

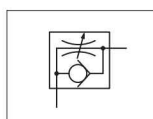
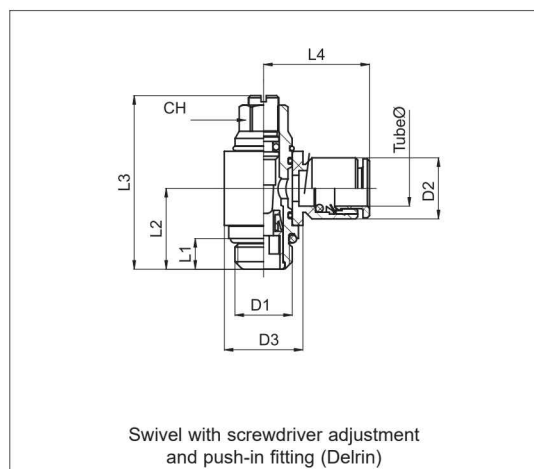

For cylinder

Code	Item	Tube Ø	D ₁	D ₂	D ₃	L ₁	L ₂	L ₃ max	L ₄	CH	gr.
024201	V38 04 M5C	4	M5	9,7	9,7	4	11,5	28	17	6	8
024202	V38 04 18C	4	1/8"	9,7	15	5	15	36	18,5	9	17
024208	V38 06 M5C	6	M5	12	9,7	4	11,5	28	20,5	6	9
024203	V38 06 18C	6	1/8"	12	15	5	15	36	22	9	18
024204	V38 06 14C	6	1/4"	12	18	6,5	18	42	23,5	10	31
024205	V38 08 18C	8	1/8"	14	15	5	15	36	22,5	9	20
024206	V38 08 14C	8	1/4"	14	18	6,5	18	42	24	10	32
024210	V38 08 38C	8	3/8"	14	22	9	22	50	26	14	59
024207	V38 10 14C	10	1/4"	16	18	6,5	18	42	26,5	10	33
024209	V38 10 38C	10	3/8"	16	22	9	22	50	28	14	60

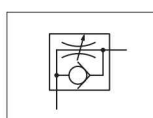
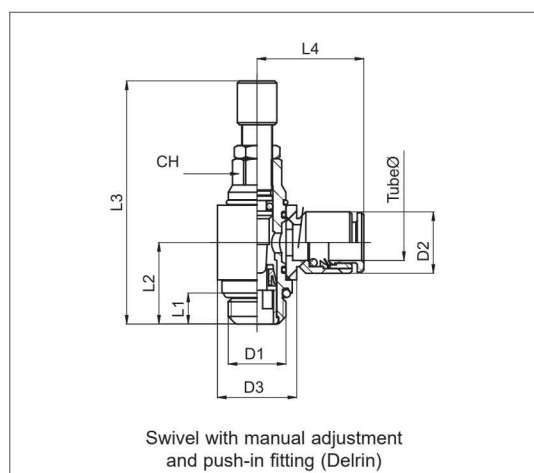

For cylinder

Code	Item	Tube Ø	D ₁	D ₂	D ₃	L ₁	L ₂	L ₃ max	L ₄	CH	gr.
024331	V36 04 M5C	4	M5	9,7	9,7	4	11,5	25,5	17	6	10
024332	V36 04 18C	4	1/8"	9,7	15	5	15	32	18,5	9	20
024333	V36 06 M5C	6	M5	12	9,7	4	11,5	25,5	20,5	6	11
024334	V36 06 18C	6	1/8"	12	15	5	15	32	22	9	21
024335	V36 06 14C	6	1/4"	12	18	6,5	18	40	23,5	10	34
024336	V36 08 18C	8	1/8"	14	15	5	15	32	22,5	9	23
024337	V36 08 14C	8	1/4"	14	18	6,5	18	40	24	10	35
024340	V36 08 38C	8	3/8"	14	22	9	22	50	26	14	59
024338	V36 10 14C	10	1/4"	16	18	6,5	18	40	26	10	36
024339	V36 10 38C	10	3/8"	16	18	9	22	50	28	14	60

Flow controls
Flow controls for cylinders

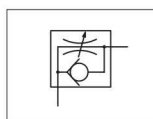
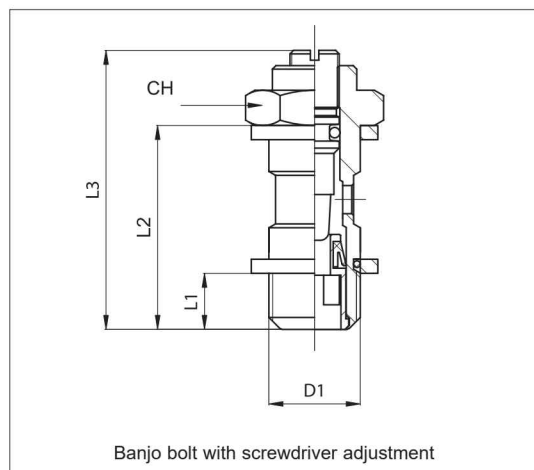

For valve

Code	Item	D ₁	L ₁	L ₂	L ₃ max	CH	gr.
024031	V15 00 M5V	M5	4	16	23,5	8	5
024032	V15 00 18V	1/8"	6	25	36	14	16
024033	V15 00 14V	1/4"	8	29	42	17	32
024034	V15 00 38V	3/8"	9	33	52	20	59

For banjo push-in fittings series R
For banjo push-in fittings series RT
For banjo rapid fittings series C
For banjo compression fittings series O
For banjo standard fittings series A

see page 4.2.9.
see page 4.5.7.
see from page 4.20.7.
see page 4.25.5.
see page 4.35.9.

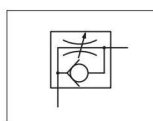
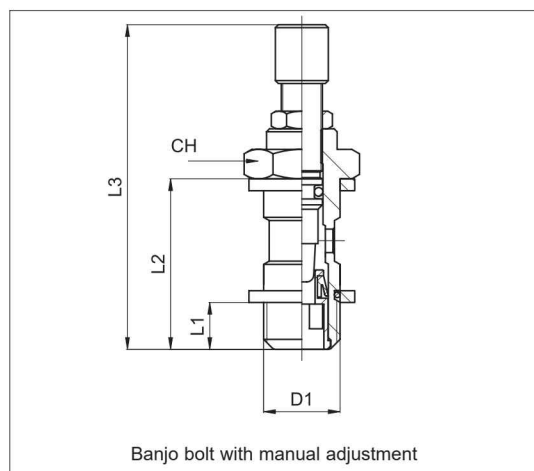

For valve

Code	Item	D ₁	L ₁	L ₂	L ₃ max	CH	gr.
024341	V14 00 M5V	M5	4	16	38,5	8	7
024342	V14 00 18V	1/8"	6	25	50	14	22
024343	V14 00 14V	1/4"	8	29	58	17	38
024344	V14 00 38V	3/8"	9	33	72	20	67

For banjo push-in fittings series R
For banjo push-in fittings series RT
For banjo rapid fittings series C
For banjo compression fittings series O
For banjo standard fittings series A

see page 4.2.9.
see page 4.5.7.
see from page 4.20.7.
see page 4.25.5.
see page 4.35.9.

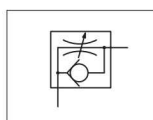
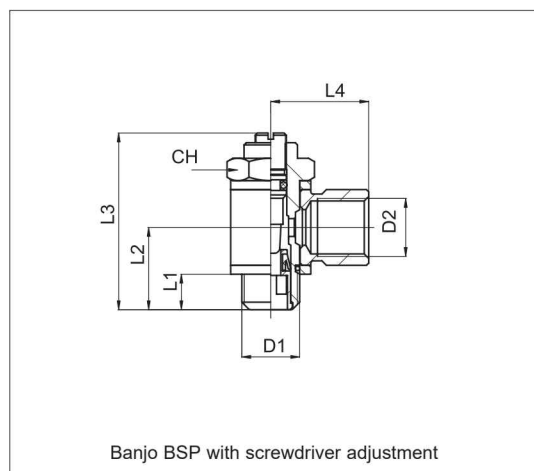

For valve

Code	Item	D ₁	D ₂	L ₁	L ₂	L ₃ max	L ₄	CH	gr.
024067	V17 00 M5V	M5	M5	4	11	23,5	11	8	12
024068	V17 00 18V	1/8"	1/8"	6	16	36	17	14	34
024069	V17 00 14V	1/4"	1/4"	8	19	42	22	17	62
024070	V17 00 38V	3/8"	3/8"	9	22	52	26	20	98

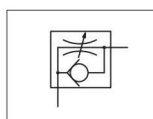
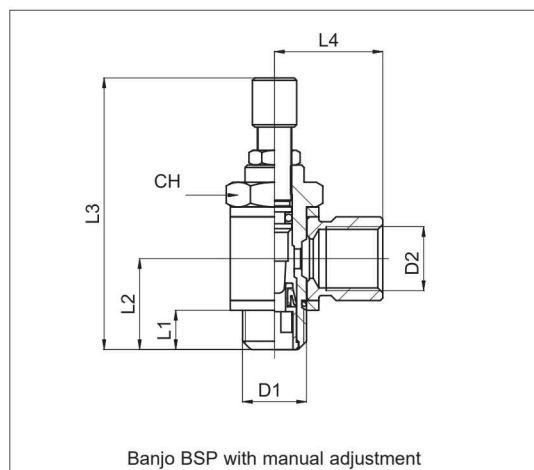

For valve

Code	Item	D ₁	D ₂	L ₁	L ₂	L ₃ max	L ₄	CH	gr.
024351	V40 00 M5V	M5	M5	4	11	38,5	11	8	14
024352	V40 00 18V	1/8"	1/8"	6	16	50	17	14	40
024353	V40 00 14V	1/4"	1/4"	8	19	58	22	17	68
024354	V40 00 38V	3/8"	3/8"	9	22	72	26	20	106

Flow controls
Flow controls for cylinders

Swivel with screwdriver adjustment and push-in fitting

For valve

Code	Item	Tube Ø	D ₁	D ₂	D ₃	L ₁	L ₂	L ₃ max	L ₄	CH	gr.
024091	V18 04 M5V	4	M5	10	10	4	11,5	28	24	6	13
024092	V18 04 18V	4	1/8"	10	14	5	15	36	24	9	31
024095	V18 06 18V	6	1/8"	13	14	5	15	36	26	9	35
024096	V18 06 14V	6	1/4"	13	18	6,5	18	42	28	10	57
024097	V18 08 18V	8	1/8"	15	14	5	15	36	28	9	39
024098	V18 08 14V	8	1/4"	15	18	6,5	18	42	28	10	56
024120	V18 08 38V	8	3/8"	14	22	9	22	50	26	14	89
024099	V18 10 14V	10	1/4"	18	18	6,5	18	42	32	10	87
024140	V18 10 38V	10	3/8"	16	22	9	22	50	28	14	86

Swivel with manual adjustment and push-in fitting

For valve

Code	Item	Tube Ø	D ₁	D ₂	D ₃	L ₁	L ₂	L ₃ max	L ₄	CH	gr.
024361	V41 04 M5V	4	M5	10	10	4	11,5	39	24	6	15
024362	V41 04 18V	4	1/8"	10	14	5	15	50	24	9	37
024365	V41 06 18V	6	1/8"	13	14	5	15	50	26	9	41
024366	V41 06 14V	6	1/4"	13	18	6,5	18	58	28	10	63
024367	V41 08 18V	8	1/8"	15	14	5	15	50	28	9	45
024368	V41 08 14V	8	1/4"	15	18	6,5	18	58	28	10	62
024370	V41 08 38V	8	3/8"	14	22	9	22	63	26	14	99
024369	V41 10 14V	10	1/4"	18	18	6,5	18	58	32	10	93
024378	V41 10 38V	10	3/8"	16	22	9	22	63	28	14	105

Swivel with screwdriver adjustment and rapid fitting

For valve

Code	Item	Tube Ø	D ₁	D ₂	L ₁	L ₂	L ₃ max	L ₄	CH ₁	CH ₂	gr.
024151	V20 04 M5V	4-2,5	M5	10	4	11,5	28	15,5	6	7	12
024155	V20 06 18V	6-4	1/8"	14	5	15	36	25	9	12	40
024156	V20 06 14V	6-4	1/4"	18	6,5	18	42	26,5	10	12	53
024157	V20 08 18V	8-6	1/8"	14	5	15	36	25	9	14	42
024158	V20 08 14V	8-6	1/4"	18	6,5	18	42	27,5	10	14	68
024172	V20 08 38V	8-6	3/8"	22	9	22	50	29,5	14	14	90
024159	V20 10 14V	10-8	1/4"	18	6,5	18	42	28,5	10	16	57
024174	V20 10 38V	10-8	3/8"	22	9	22	50	30,5	14	16	92

Banjo with screwdriver adjustment and push-in fitting (Delrin)

For valve

Code	Item	Tube Ø	D ₁	D ₂	L ₁	L ₂	L ₃ max	L ₄	CH	gr.
024119	V39 04 M5V	4	M5	9,7	6	11	23,5	17	8	7
024111	V39 04 18V	4	1/8"	9,7	7	16	36	18,5	14	20
024230	V39 06 M5V	6	M5	12	6	11	23,5	20,5	8	8
024113	V39 06 18V	6	1/8"	12	7	16	36	22	14	22
024114	V39 06 14V	6	1/4"	12	9	19	42	23,5	17	38
024115	V39 08 18V	8	1/8"	14	7	16	36	22,5	14	22
024116	V39 08 14V	8	1/4"	14	9	19	42	24	17	39
024231	V39 08 38V	8	3/8"	14	10	22	52	26	20	67
024117	V39 10 14V	10	1/4"	16,5	9	19	42	26	17	39
024118	V39 10 38V	10	3/8"	16,5	10	22	52	28	20	68

Flow controls
Flow controls for cylinders

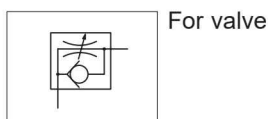
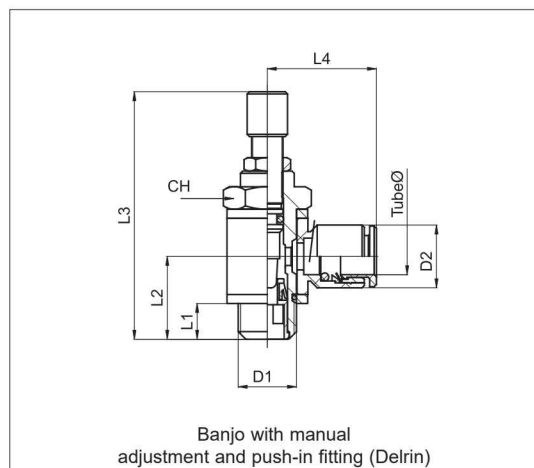

Code	Item	Tube Ø	D1	D2	L1	L2	L3 max	L4	CH	gr.
024381	V37 04 M5V	4	M5	9,7	4	11	38,5	17	8	9
024382	V37 04 18V	4	1/8"	9,7	6	16	50	18,5	14	23
024383	V37 06 M5V	6	M5	12	4	11	38,5	20,5	8	10
024384	V37 06 18V	6	1/8"	12	6	16	50	22	14	25
024385	V37 06 14V	6	1/4"	12	8	19	58	23,5	17	41
024386	V37 08 18V	8	1/8"	14	6	16	50	22,5	14	25
024387	V37 08 14V	8	1/4"	14	8	19	58	24	17	42
024388	V37 08 38V	8	3/8"	14	9	22	72	26	20	70
024389	V37 10 14V	10	1/4"	16,5	8	19	58	26	17	42
024390	V37 10 38V	10	3/8"	16,5	9	22	72	28	20	71

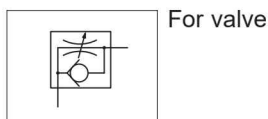
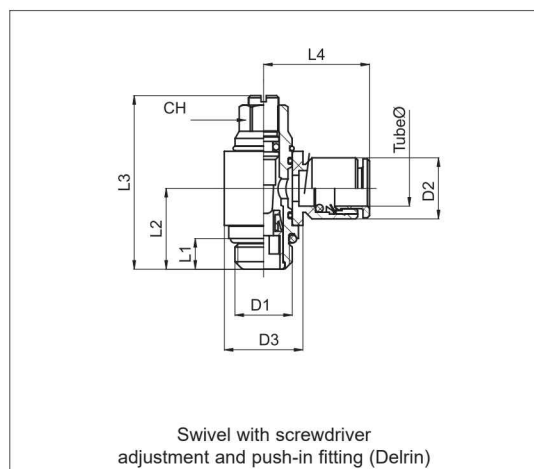

Code	Item	Tube Ø	D1	D2	D3	L1	L2	L3 max	L4	CH	gr.
024211	V38 04 M5V	4	M5	9,7	9,7	4	11,5	28	17	6	8
024212	V38 04 18V	4	1/8"	9,7	15	5	15	36	18,5	9	17
024218	V38 06 M5V	6	M5	12	9,7	4	11,5	28	20,5	6	9
024213	V38 06 18V	6	1/8"	12	15	5	15	36	22	9	18
024214	V38 06 14V	6	1/4"	12	18	6,5	18	42	23,5	10	31
024215	V38 08 18V	8	1/8"	14	15	5	15	36	22,5	9	20
024216	V38 08 14V	8	1/4"	14	18	6,5	18	42	24	10	32
024219	V38 08 38V	8	3/8"	14	22	9	22	50	26	14	59
024217	V38 10 14V	10	1/4"	16	18	6,5	18	42	26,5	10	33
024220	V38 10 38V	10	3/8"	16	22	9	22	50	28	14	60

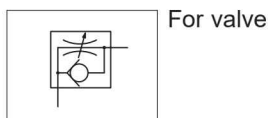
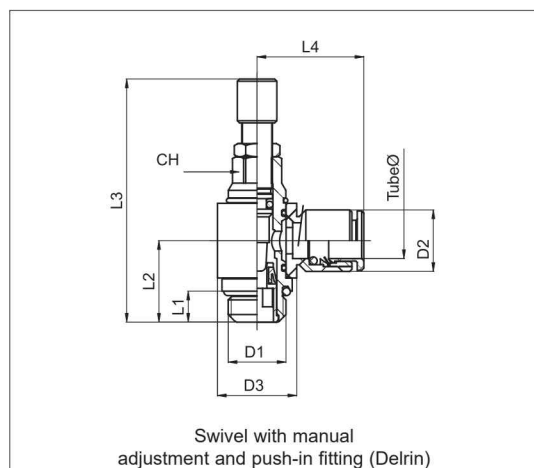

Code	Item	Tube Ø	D1	D2	D3	L1	L2	L3 max	L4	CH	gr.
024401	V36 04 M5V	4	M5	9,7	9,7	4	11,5	39	17	6	10
024402	V36 04 18V	4	1/8"	9,7	15	5	15	50	18,5	9	20
024403	V36 06 M5V	6	M5	12	9,7	4	11,5	39	20,5	6	11
024404	V36 06 18V	6	1/8"	12	15	5	15	50	22	9	21
024405	V36 06 14V	6	1/4"	12	18	6,5	18	58	23,5	10	34
024406	V36 08 18V	8	1/8"	14	15	5	15	50	22,5	9	23
024407	V36 08 14V	8	1/4"	14	18	6,5	18	58	24	10	35
024409	V36 08 38V	8	3/8"	14	22	9	22	50	26	14	59
024408	V36 10 14V	10	1/4"	16	18	6,5	18	58	26	10	36
024410	V36 10 38V	10	3/8"	16	22	9	22	50	28	14	60

Flow controls
Flow controls for cylinders

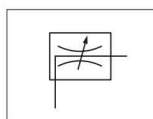
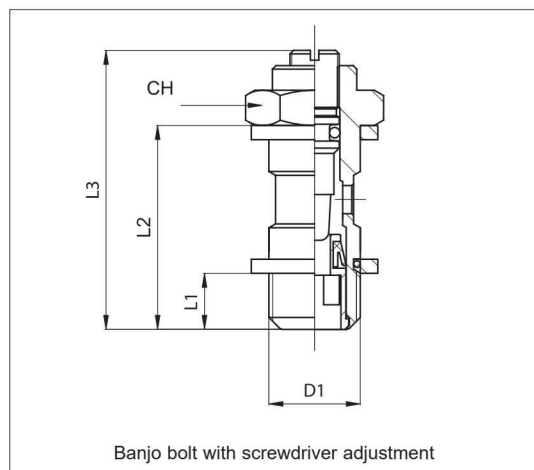

Bi-directional

Code	Item	D ₁	L ₁	L ₂	L ₃ max	CH	gr.
024001	V15 00 M5B	M5	4	16	23,5	8	5
024002	V15 00 18B	1/8"	6	25	36	14	16
024003	V15 00 14B	1/4"	8	29	42	17	32
024004	V15 00 38B	3/8"	9	33	52	20	59
024005	V15 00 12B	1/2"	10	39	61	26	108

For banjo push-in fittings series R
For banjo push-in fittings series RT
For banjo rapid fittings series C
For banjo compression fittings series O
For banjo standard fittings series A

see page 4.2.9.
see page 4.5.7.
see from page 4.20.7.
see page 4.25.5.
see page 4.35.9.

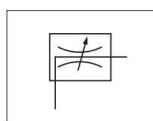
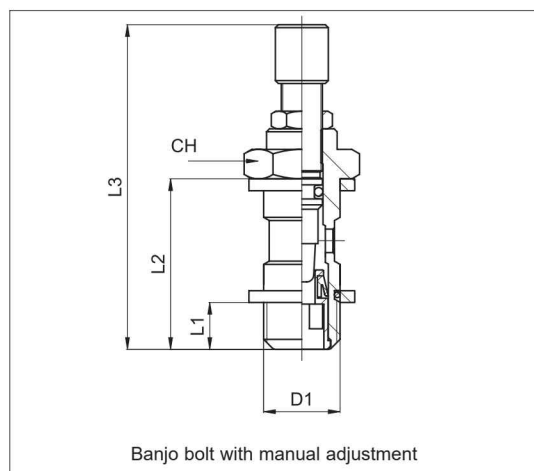

Bi-directional

Code	Item	D ₁	L ₁	L ₂	L ₃ max	CH	gr.
024411	V14 00 M5B	M5	4	16	38,5	8	7
024412	V14 00 18B	1/8"	6	25	50	14	22
024413	V14 00 14B	1/4"	8	29	58	17	38
024414	V14 00 38B	3/8"	9	33	72	20	67
024415	V14 00 12B	1/2"	10	39	81	26	121

For banjo push-in fittings series R
For banjo push-in fittings series RT
For banjo rapid fittings series C
For banjo compression fittings series O
For banjo standard fittings series A

see page 4.2.9.
see page 4.5.7.
see from page 4.20.7.
see page 4.25.5.
see page 4.35.9.

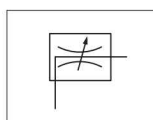
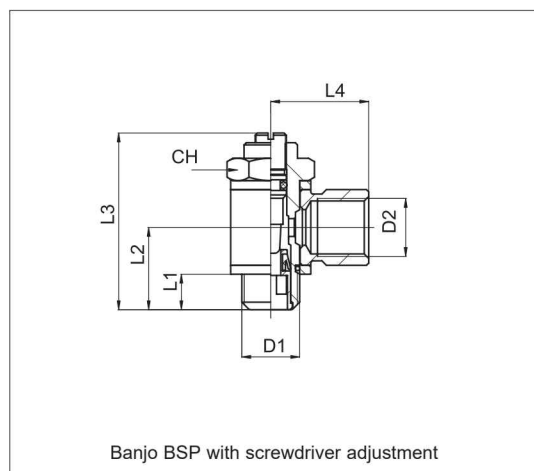

Bi-directional

Code	Item	D ₁	D ₂	L ₁	L ₂	L ₃ max	L ₄	CH	gr.
024073	V17 00 M5B	M5	M5	4	11	23,5	11	8	12
024074	V17 00 18B	1/8"	1/8"	6	16	36	17	14	34
024075	V17 00 14B	1/4"	1/4"	8	19	42	22	17	62
024076	V17 00 38B	3/8"	3/8"	9	22	52	26	20	98
024077	V17 00 12B	1/2"	1/2"	10	25	61	32	26	176

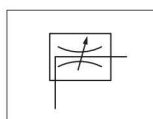
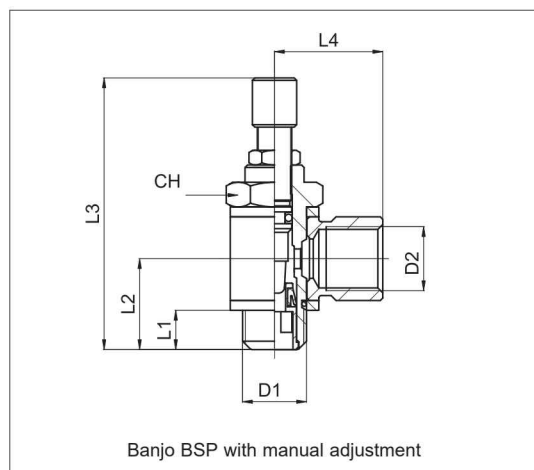

Bi-directional

Code	Item	D ₁	D ₂	L ₁	L ₂	L ₃ max	L ₄	CH	gr.
024421	V40 00 M5B	M5	M5	4	11	38,5	11	8	14
024422	V40 00 18B	1/8"	1/8"	6	16	50	17	14	40
024423	V40 00 14B	1/4"	1/4"	8	19	58	22	17	68
024424	V40 00 38B	3/8"	3/8"	9	22	72	26	20	106
024425	V40 00 12B	1/2"	1/2"	10	25	81	32	26	189

Flow controls
Flow controls for cylinders

Swivel with screwdriver adjustment and push-in fitting

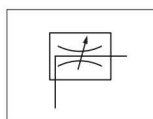

Bi-directional

Code	Item	Tube Ø	D ₁	D ₂	D ₃	L ₁	L ₂	L ₃ max	L ₄	CH	gr.
024131	V18 04 M5B	4	M5	10	10	4	11,5	28	24	6	13
024132	V18 04 18B	4	1/8"	10	14	5	15	36	24	9	31
024135	V18 06 18B	6	1/8"	13	14	5	15	36	26	9	35
024136	V18 06 14B	6	1/4"	13	18	6,5	18	42	28	10	57
024137	V18 08 18B	8	1/8"	15	14	5	15	36	28	9	39
024138	V18 08 14B	8	1/4"	15	18	6,5	18	42	28	10	56
024175	V18 08 38B	8	3/8"	14	22	9	22	50	26	14	89
024139	V18 10 14B	10	1/4"	18	18	6,5	18	42	32	10	87
024176	V18 10 38B	10	3/8"	16	22	9	22	50	28	14	86

Swivel with manual adjustment and push-in fitting

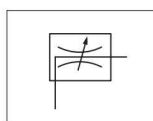

Bi-directional

Code	Item	Tube Ø	D ₁	D ₂	D ₃	L ₁	L ₂	L ₃ max	L ₄	CH	gr.
024431	V41 04 M5B	4	M5	10	10	4	11,5	39	24	6	15
024432	V41 04 18B	4	1/8"	10	14	5	15	50	24	9	37
024435	V41 06 18B	6	1/8"	13	14	5	15	50	26	9	41
024436	V41 06 14B	6	1/4"	13	18	6,5	18	58	28	10	63
024437	V41 08 18B	8	1/8"	15	14	5	15	50	28	9	45
024438	V41 08 14B	8	1/4"	15	18	6,5	18	58	28	10	62
024440	V41 08 38B	8	3/8"	14	22	9	22	63	26	14	99
024439	V41 10 14B	10	1/4"	18	18	6,5	18	58	32	10	93
024450	V41 10 38B	10	3/8"	16	22	9	22	63	28	14	105

Swivel with screwdriver adjustment and rapid fitting

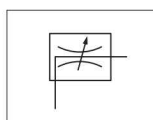

Bi-directional

Code	Item	Tube Ø	D ₁	D ₂	L ₁	L ₂	L ₃ max	L ₄	CH ₁	CH ₂	gr.
024161	V20 04 M5B	4-2,5	M5	10	4	11,5	28	15,5	6	7	12
024164	V20 06 M5B	6-4	M5	10	4	11,5	28	19	6	9	12
024165	V20 06 18B	6-4	1/8"	14	5	15	36	25	9	12	40
024166	V20 06 14B	6-4	1/4"	18	6,5	18	42	26,5	10	12	53
024167	V20 08 18B	8-6	1/8"	14	5	15	36	25	9	14	42
024168	V20 08 14B	8-6	1/4"	18	6,5	18	42	27,5	10	14	68
024177	V20 08 38B	8-6	3/8"	22	9	22	50	29,5	14	14	90
024169	V20 10 14B	10-8	1/4"	18	6,5	18	42	28,5	10	16	57
024178	V20 10 38B	10-8	3/8"	22	9	22	50	30,5	14	16	92

Banjo with screwdriver adjustment and push-in fitting (Delrin)

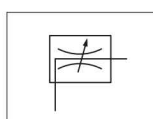

Bi-directional

Code	Item	Tube Ø	D ₁	D ₂	L ₁	L ₂	L ₃ max	L ₄	CH	gr.
024120	V39 04 M5B	4	M5	9,7	6	11	23,5	17	8	7
024121	V39 04 18B	4	1/8"	9,7	7	16	36	18,5	14	20
024129	V39 06 M5B	6	M5	12	6	11	23,5	20,5	8	8
024123	V39 06 18B	6	1/8"	12	7	16	36	22	14	22
024124	V39 06 14B	6	1/4"	12	9	19	42	23,5	17	38
024125	V39 08 18B	8	1/8"	14	7	16	36	22,5	14	22
024126	V39 08 14B	8	1/4"	14	9	19	42	24	17	39
024130	V39 08 38B	8	3/8"	14	10	22	52	26	20	67
024127	V39 10 14B	10	1/4"	16,5	9	19	42	26	17	39
024128	V39 10 38B	10	3/8"	16,5	10	22	52	28	20	68

Flow controls
Flow controls for cylinders

Banjo with manual adjustment and push-in fitting (Delrin)

Bi-directional

Code	Item	Tube Ø	D1	D2	L1	L2	L3 max	L4	CH	gr.
024451	V37 04 M5B	4	M5	9,7	4	11	38,5	17	8	9
024452	V37 04 18B	4	1/8"	9,7	6	16	50	18,5	14	23
024453	V37 06 M5B	6	M5	12	4	11	38,5	20,5	8	10
024454	V37 06 18B	6	1/8"	12	6	16	50	22	14	25
024455	V37 06 14B	6	1/4"	12	8	19	58	23,5	17	41
024456	V37 08 18B	8	1/8"	14	6	16	50	22,5	14	25
024457	V37 08 14B	8	1/4"	14	8	19	58	24	17	42
024458	V37 08 38B	8	3/8"	14	9	22	72	26	20	70
024459	V37 10 14B	10	1/4"	16,5	8	19	58	26	17	42
024460	V37 10 38B	10	3/8"	16,5	9	22	72	28	20	71

Swivel with screwdriver adjustment and push-in fitting (Delrin)

Bi-directional

Code	Item	Tube Ø	D1	D2	D3	L1	L2	L3 max	L4	CH	gr.
024221	V38 04 M5B	4	M5	9,7	9,7	4	11,5	28	17	6	8
024222	V38 04 18B	4	1/8"	9,7	15	5	15	36	18,5	9	17
024227	V38 06 M5B	6	M5	12	9,7	4	11,5	28	20,5	6	9
024223	V38 06 18B	6	1/8"	12	15	5	15	36	22	9	18
024224	V38 06 14B	6	1/4"	12	18	6,5	18	42	23,5	10	31
024225	V38 08 18B	8	1/8"	14	15	5	15	36	22,5	9	20
024226	V38 08 14B	8	1/4"	14	18	6,5	18	42	24	10	32
024229	V38 08 38B	8	3/8"	14	22	9	22	50	26	14	59
024228	V38 10 14B	10	1/4"	16	18	6,5	18	42	26,5	10	33
024254	V38 10 38B	10	3/8"	16	22	9	22	50	28	14	60

Swivel with manual adjustment and push-in fitting (Delrin)

Bi-directional

Code	Item	Tube Ø	D1	D2	D3	L1	L2	L3 max	L4	CH	gr.
024481	V36 04 M5B	4	M5	9,7	9,7	4	11,5	39	17	6	10
024482	V36 04 18B	4	1/8"	9,7	15	5	15	50	18,5	9	20
024483	V36 06 M5B	6	M5	12	9,7	4	11,5	39	20,5	6	11
024484	V36 06 18B	6	1/8"	12	15	5	15	50	22	9	21
024485	V36 06 14B	6	1/4"	12	18	6,5	18	58	23,5	10	34
024486	V36 08 18B	8	1/8"	14	15	5	15	50	22,5	9	23
024487	V36 08 14B	8	1/4"	14	18	6,5	18	58	24	10	35
024487	V36 08 38B	8	3/8"	14	22	9	22	50	26	14	59
024488	V36 10 14B	10	1/4"	16	18	6,5	18	58	26	10	36
024488	V36 10 38B	10	3/8"	16	22	9	22	50	28	14	60

Type: V18 - V41

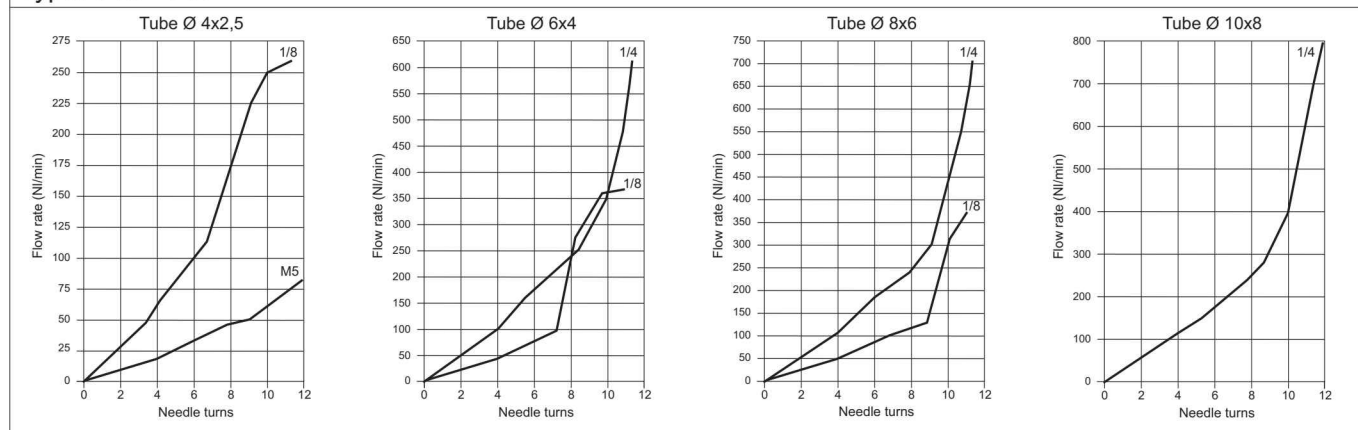

Type: V20

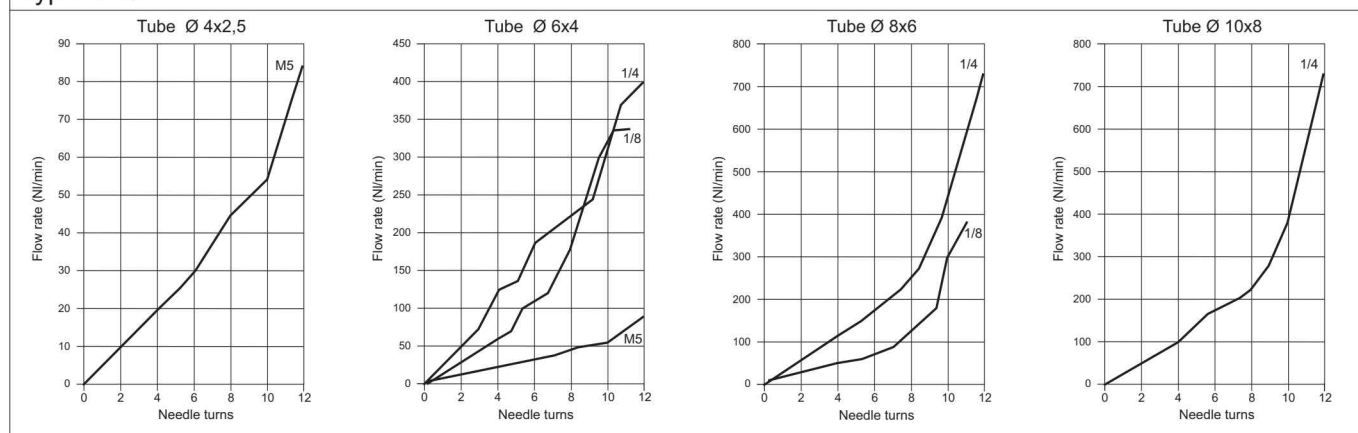

Type: V37 - V39

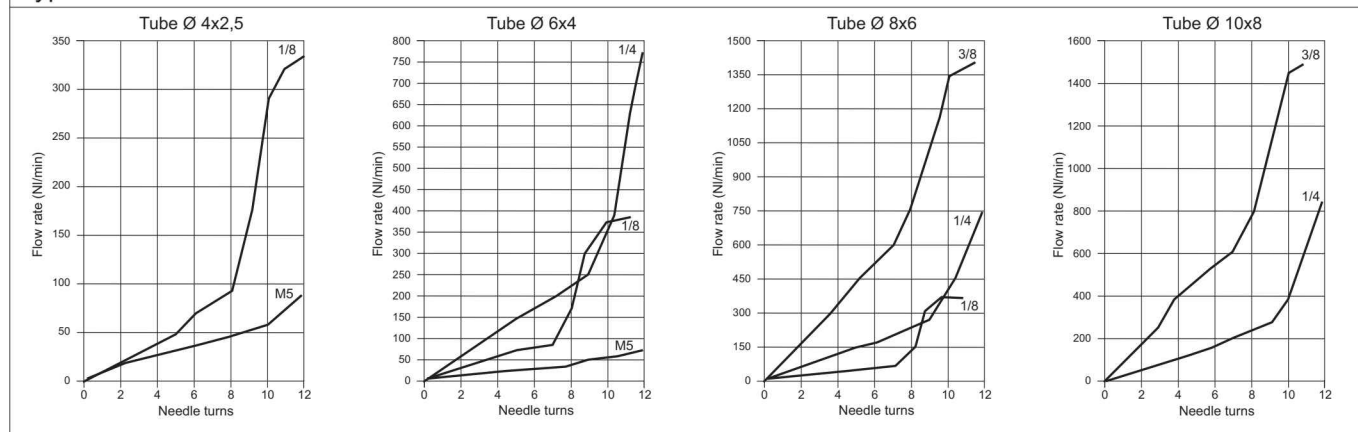

Type: V36 - V38

