

Dynamic piston-rod brake for Cylinders ISO 15552

Bores from 32 to 100 mm

Standard executions			
Version	Symbol	Code	Item
Normally closed		042035	ABK32
		042036	ABK40
		042037	ABK50
		042038	ABK63
		042039	ABK80
		042040	ABK100



Series of dynamic locking-rod units for cylinders ISO15552. The piston-rod brakes series ABK can be supplied normally closed. The peculiarity of this series is to lock the cylinder piston-rod while moving and to hold it still even in presence of pressure in the chamber.

A special feature of the series ABK is the absolute absence of axial movement and rotation of the cylinder piston-rod.

For the application of the piston-rod brake ABK to a cylinder ISO15552 is necessary to order the cylinder with the rod predisposed for this (the extended one in hardened steel, option B1, see page 1.5.1).

How to order: ABK050

ABK	050	
Type	Cylinder bore	Option

Seal kits not available.

Technical data							
Bores (mm)	32	40	50	63	80	100	
Fluid	Compressed filtered air with or without lubrication						
Pressure range	4 ÷ 6.5 bar						
Min. working pressure (bar)	4.0	4.0	3.5	3.5	3.0	3.0	
Locking model	Secure locking of piston rod in any position						
Locking force (N)	510	860	1275	2060	3300	4620	
Lock braking precision (mm)	V (mm/sec)	(Horizontal axis) operate with a load ratio of 70% or less, (Vertical axis) Operate with a load ratio of 35% or less					
	50 (mm/sec)	±0.7	±0.8	±0.9	±0.8	±0.8	±1
	100 (mm/sec)	±1	±1	±1	±1	±1.2	±1.4
	200 (mm/sec)	±1.3	±1.6	±1.4	±1.8	±2.1	±2.4
Allowable energy (max) J(N • m) J(E _{k=1/2 mv²})	0.84	1.41	2.2	3.31	4.98	7.57	
Temperature range	-10 °C ÷ +60° C						

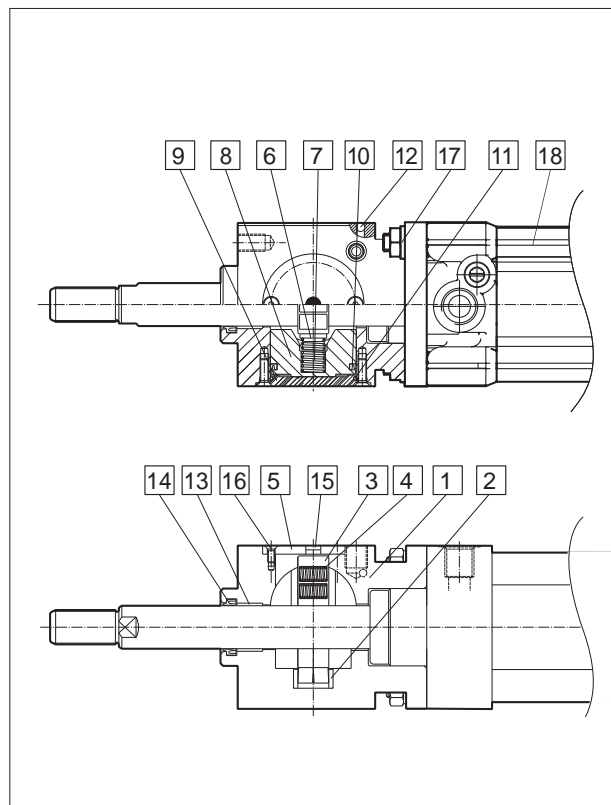

Materials (standard types)		
1	Body	Hard anodised aluminium alloy
2	Slide bush	Carbon steel
3	Locking unit	Brass
4	Spring	SWPA
5	Dust cover	Hard anodised aluminium alloy
6	Spring holder	POM
7	Spring	SWPA
8	Piston	POM
9	End cover	Hard anodised aluminium alloy
10	Piston packing	PU
11	O-ring	NBR
12	Steel ball	Carbon steel
13	Oilless bearing	Sintered bronze
14	Rod packing	NBR
15	Silencer	Cooper
16	Tie bolt	Carbon steel nickel plated
17	Tie bolt	Carbon steel blackening
18	Cylinder	-

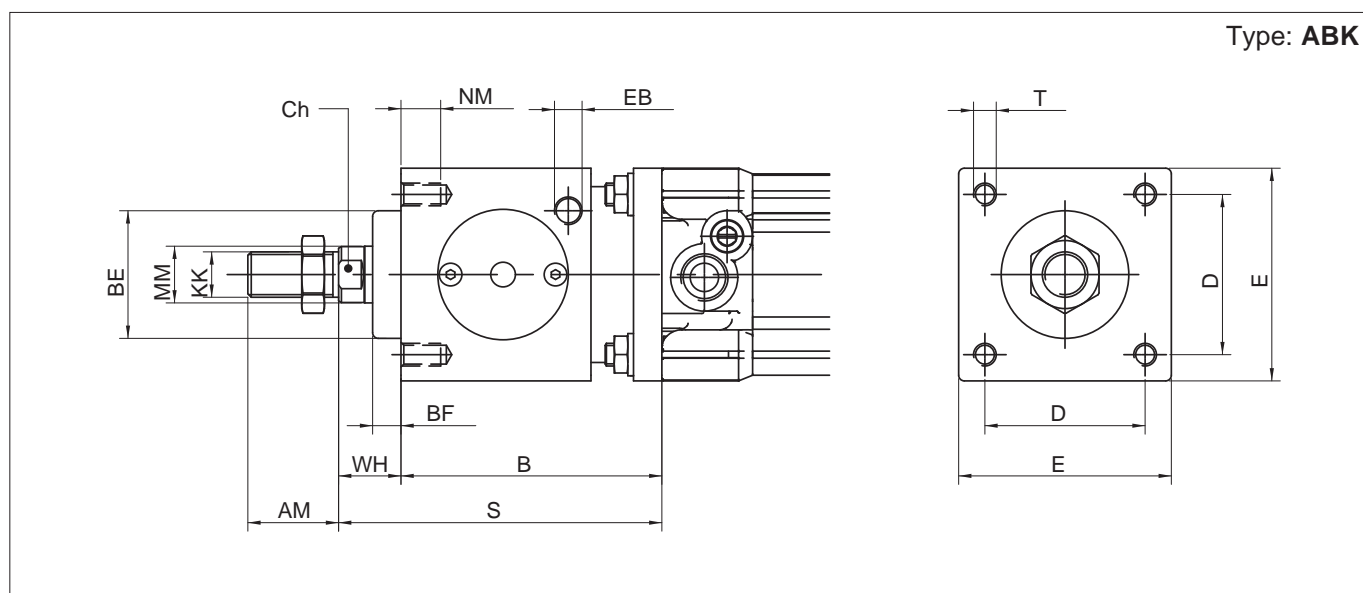

For cylinder Ø mm	AM	B	BE	BF	Ch	D	E	EB	KK	MM Ø f7	NM	S	T	WH
32	22	73	30	8	10	32.5	47	1/8"	M10x1.25	12	12	99	M6	26
40	24	76	35	8	13	38	53	1/8"	M12x1.25	16	12	106	M6	30
50	32	90	40	8	17	46.5	65	1/8"	M16x1.5	20	14	127	M8	37
63	32	92	45	10	17	56.5	75	1/8"	M16x1.5	20	14	129	M8	37
80	40	110	45	10	22	72	95	1/4"	M20x1.5	25	16	156	M10	46
100	40	130	55	10	27	89	115	1/4"	M20x1.5	25	16	181	M10	51

Features and Applications

Horizontal application

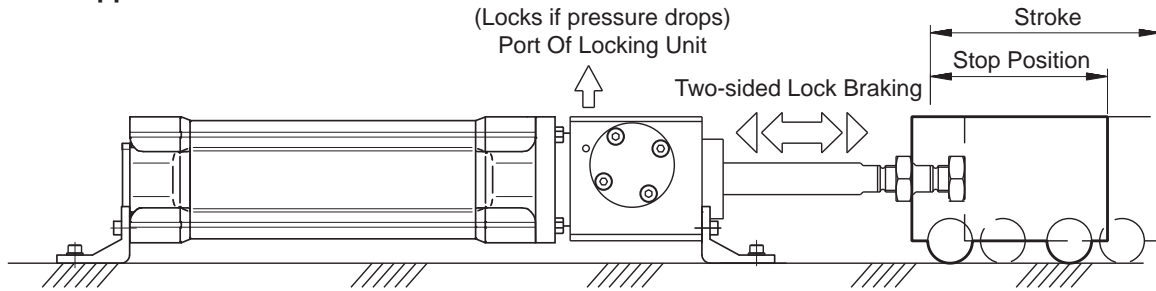

EXAMPLE 1

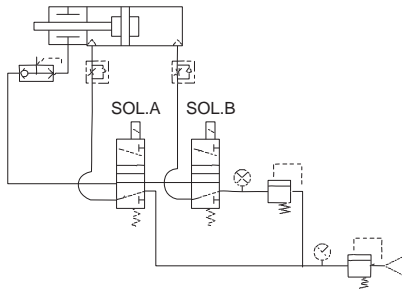

SOL. A	SOL. B	ACTION STATE
ON	OFF	extended
OFF	OFF	stop
ON	OFF	extended
OFF	ON	retract
OFF	OFF	stop
OFF	ON	retract

EXAMPLE 2

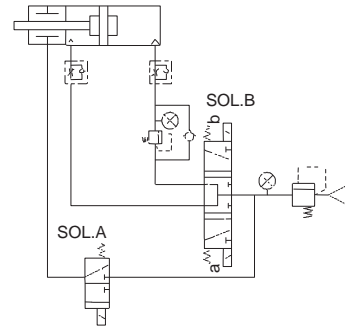

SOL. A	SOL. B		ACTION STATE
	a	b	
ON	OFF	ON	extended
OFF	OFF	OFF	stop
ON	OFF	ON	extended
ON	ON	OFF	retract
OFF	OFF	OFF	stop
ON	ON	OFF	retract

Vertical application

Allowable kinetic energy

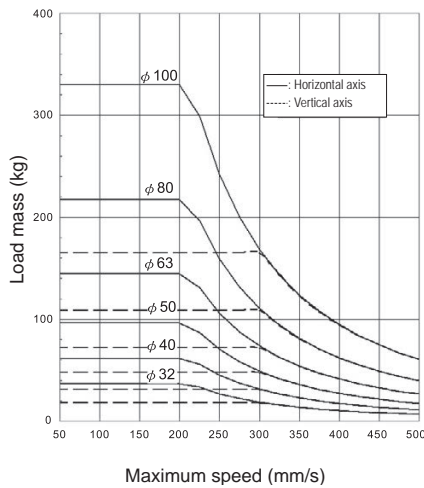

$$Ek = \frac{1}{2}mv^2$$

Ek: Kinetic energy (J)
v: Speed (m/s)
m: Weight (kg)

