

Standard executions		
Version	Code	Item
Ø 50	811168	GDB050
Ø 70	811169	GDB070
Ø 102	811170	GDB102
Ø 140	811171	GDB140
Ø 165	811173	GDB165
Ø 254	811174	GDB254

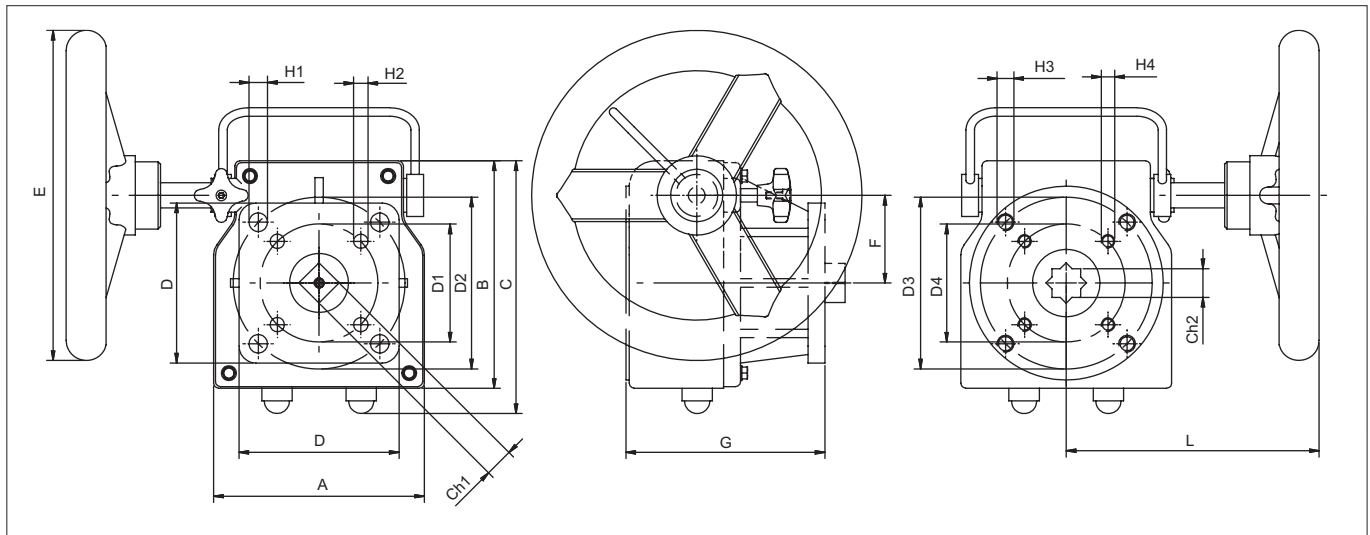

Series of new generation handweel manipulators, compact and universal, with IP67 protection.
The design of these manipulators allow to chose on positioning between valve and actuator, function of manipulator can be reversed.

Manipulator is placed between valve and actuator: valve pin can be directly mounted to the actuator pinion through the manipulator body, or by an adaptor (in case a bracket should be applied).
During automatic working, handweel is off; connecting the manual function, the handweel will move both the ball-valve and the actuator.



Item	A	B	C	E	F	G	L	D1	H1	D2	H2	D3	H3	D4	H4	Ch1	Ch2
GDB050	90	110	125	Ø 200	44	100	143	Ø 50	Ø 8,5	Ø 70	Ø 6,5	Ø 70	M8x12	Ø 50	M6x10	14	17
GDB070	125	135	150	Ø 200	52	118	177	Ø 70	Ø 11	Ø 102	Ø 8,5	Ø 102	M10x15	Ø 70	M8x12	14	17
GDB102	140	160	185	Ø 300	85	124	190	Ø 102	Ø 13	Ø 125	Ø 11	Ø 125	M12x18	Ø 102	M10x15	22	27
GDB140	185	200	230	Ø 400	85	162	325	Ø 102	Ø 17	Ø 140	Ø 11	Ø 140	M16x24	Ø 102	M10x15	27	36
GDB165	230	243	268	Ø 600	104	181	395	-	Ø 21	Ø 165	-	Ø 140	M16x24	-	-	36	36
GDB254	265	283	330	Ø 700	130	205	400	Ø 165	Ø 21	Ø 254	Ø 17	Ø 254	M20x30	Ø 165	M16x24	46	60

Item	Gear ratio	Output torque
GDB050	1 : 40	300 Nm
GDB070	1 : 38	360 Nm
GDB102	1 : 36	810 Nm
GDB140	1 : 50	1.310 Nm
GDB165	1 : 55	2.800 Nm
GDB254	1 : 62	5.500 Nm

Technical data		
Materials	Handle:	Carbon steel
	Worm shaft:	C45
	Handwheel:	Grey cast iron
	Positioning screw:	Carbon steel
	Worm gear:	Steel
	Bracket cap:	Grey cast iron
	Body:	Grey cast iron