

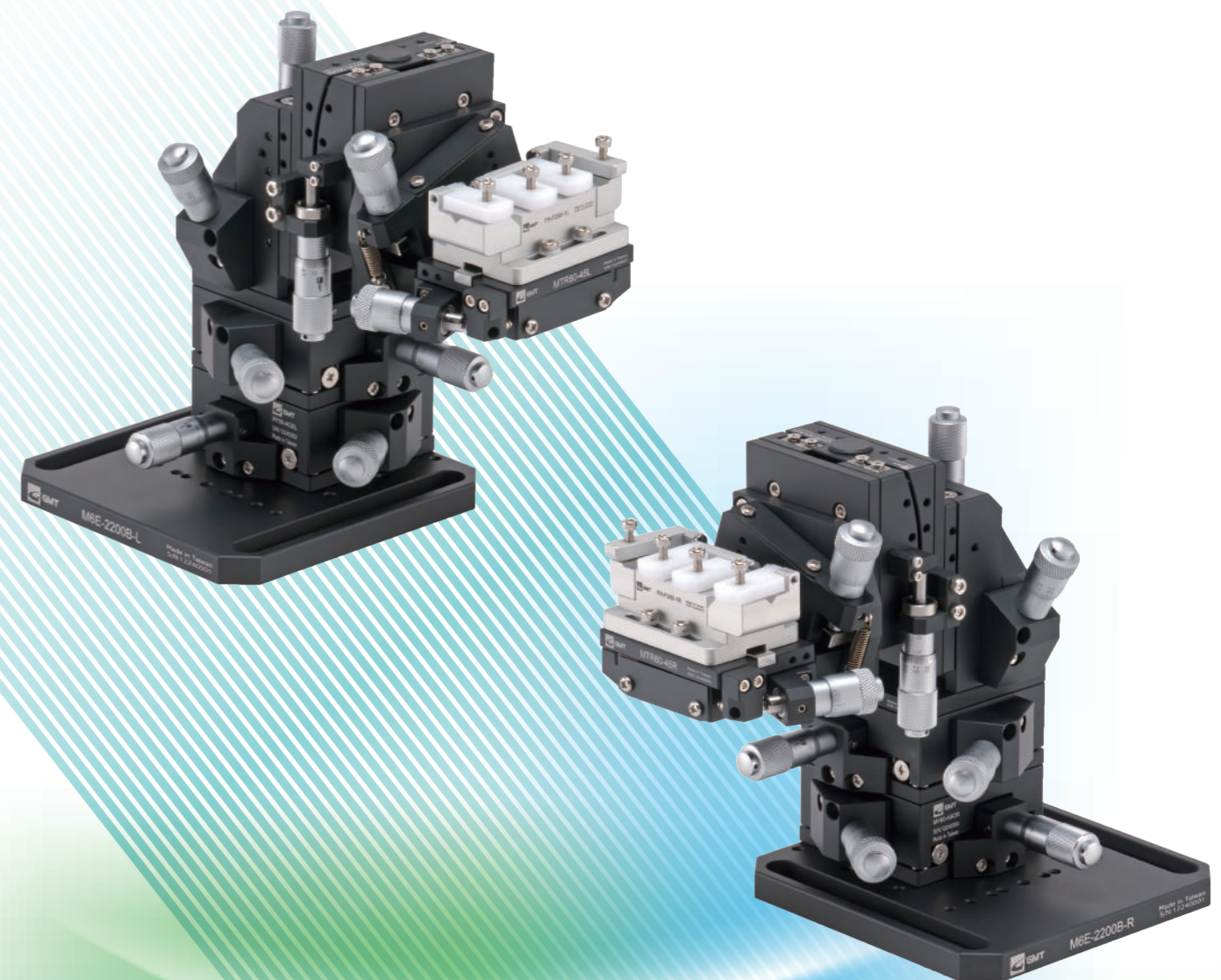

High - Resolution  
Positioning Stage



Manufactory&Headquarter

No. 3, Lane 34, Minju Street,  
Shioushuei Township,  
50442 Changhua County Taiwan.  
Tel: (886) 4 7688320  
Fax: (886) 4 7688314  
Email: sales@gmtglobalinc.com  
Site: www.gmtlinear.com



2013.04

www.gmtlinear.com



## Hi-Resolution Positioning Stage Left hand tuning

### M3E-2000S-L

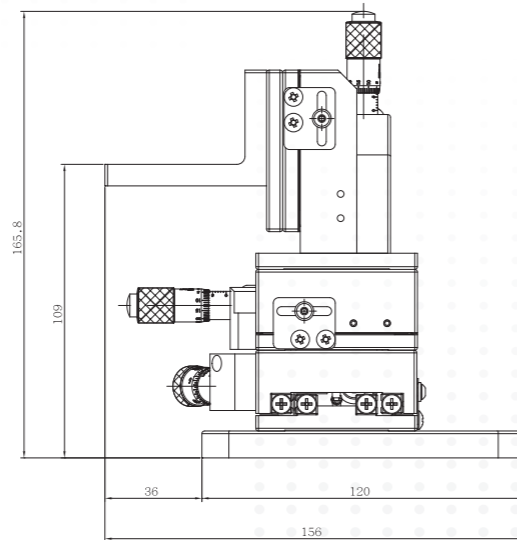
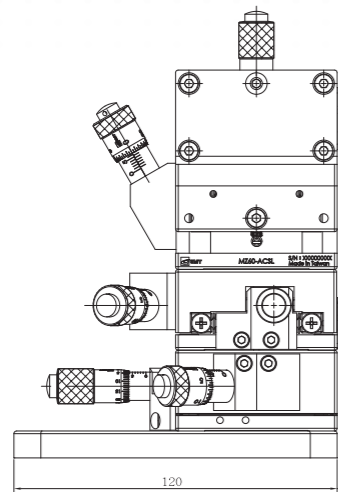
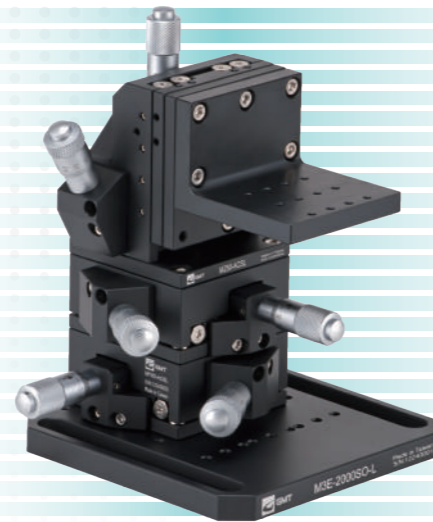
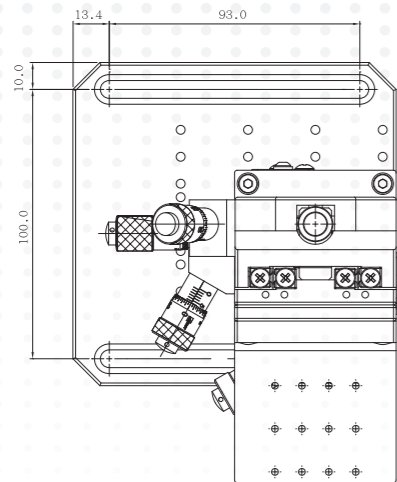

### M3E-2000S-L

Specification / Axis	Travel Stroke		Resolution	
	Coarse Tuning	Fine Tuning	Coarse Tuning	Fine Tuning
X	±6.5mm	±0.3mm	10um	0.5um
Y	±6.5mm	±0.3mm	10um	0.5um
Z	±6.5mm	±0.3mm	10um	0.5um

M3E-2000S model is consisted XYZ manual positioning stages accembled with one L bracket to perform tilt movement.

Remark: Available option of XYZ module with ordering code: MXYZ60-ACSL

## Hi-Resolution Positioning Stage Right hand tuning

### M3E-2000S-R

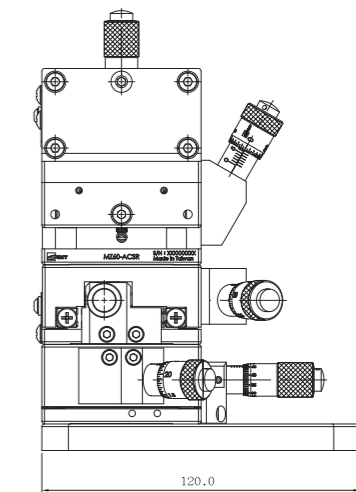
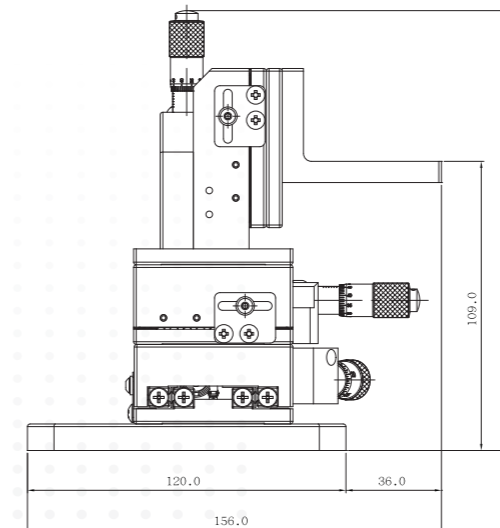
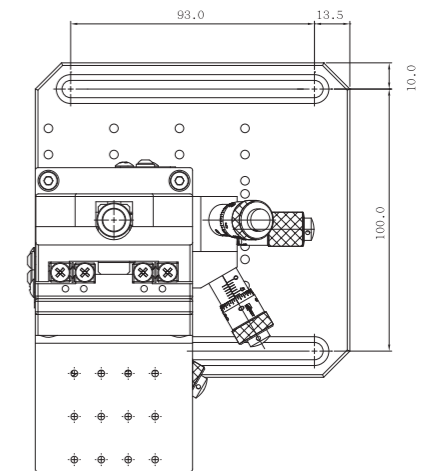
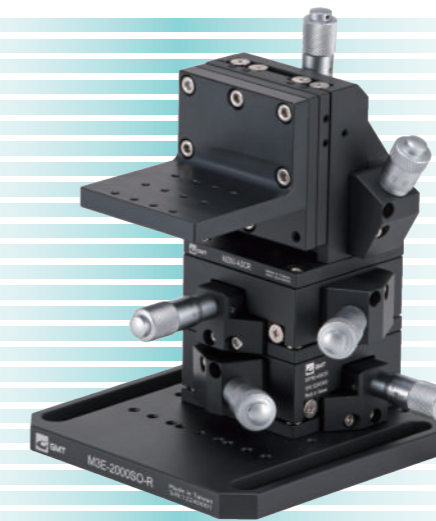

### M3E-2000S-R

Specification / Axis	Travel Stroke		Resolution	
	Coarse Tuning	Fine Tuning	Coarse Tuning	Fine Tuning
X	±6.5mm	±0.3mm	10um	0.5um
Y	±6.5mm	±0.3mm	10um	0.5um
Z	±6.5mm	±0.3mm	10um	0.5um

M3E-2000S model is consisted XYZ manual positioning stages accembled with one L bracket to perform tilt movement.

Remark: Available option of XYZ module with ordering code: MXYZ60-ACSR



## Hi-Resolution Positioning Stage Left hand tuning

### M5E-2000B-L

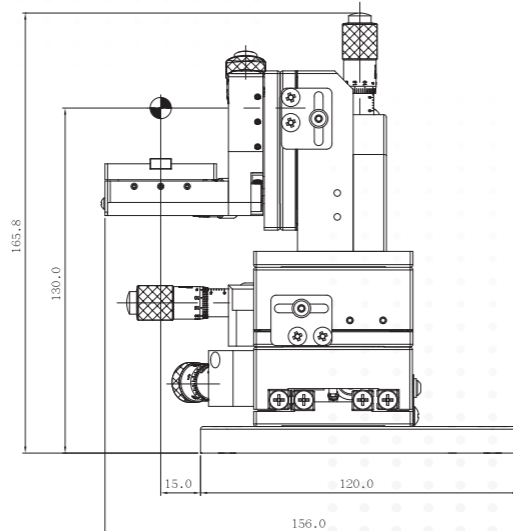
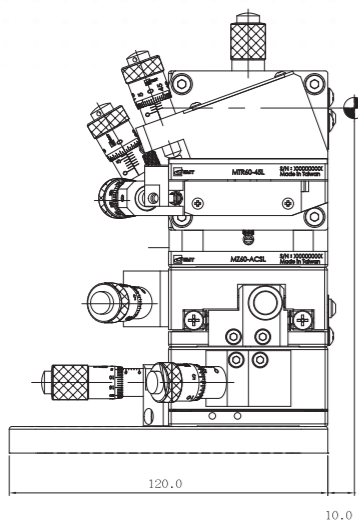
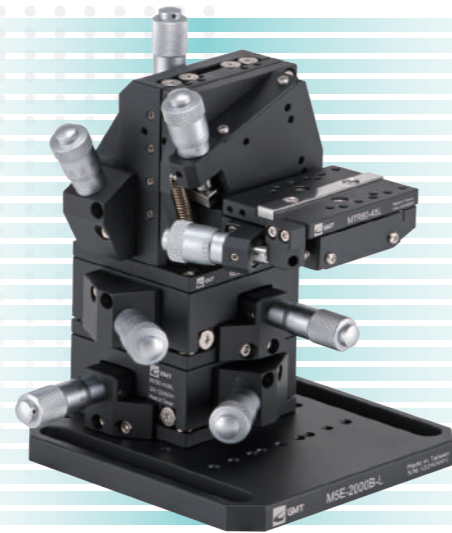
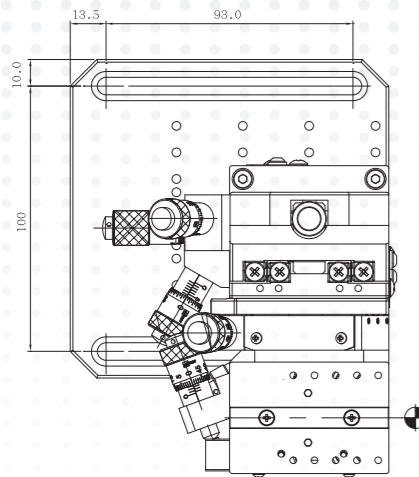

### M5E-2000B-L

Specification / Axis	Travel Stroke		Resolution	
	Coarse Tuning	Fine Tuning	Coarse Tuning	Fine Tuning
X	±6.5mm	±0.3mm	10um	0.5um
Y	±6.5mm	±0.3mm	10um	0.5um
Z	±6.5mm	±0.3mm	10um	0.5um
θx	±3° mm		≅ 29.3"/div.	
θy	±3° mm		≅ 27.8"/div.	

M5E-2000S model is consisted XYZ manual positioning stages assembled with tilt stage (θx, θy) to perform a unit with 5-axis high resolution positioning stage.  
The complete assembly is mostly applied to single-fiber alignment equipment.

Remark: Available option of XYZ module with ordering code: MXYZ60-ACSL;  
Tilt module with ordering code: MTR60-45L

## Hi-Resolution Positioning Stage Right hand tuning

### M5E-2000B-R

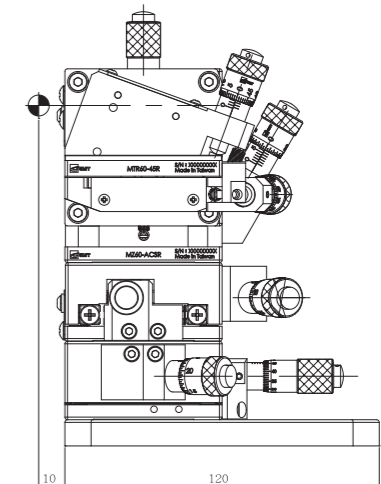
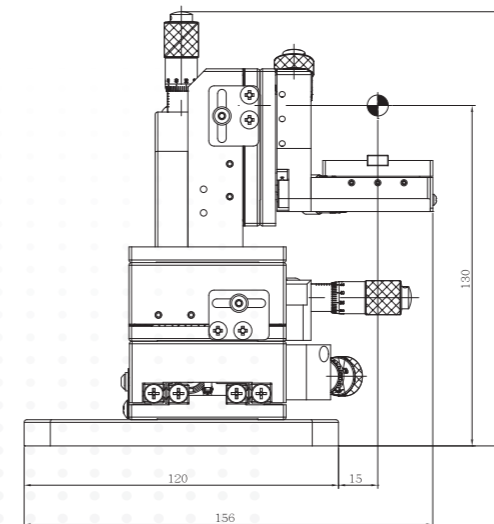
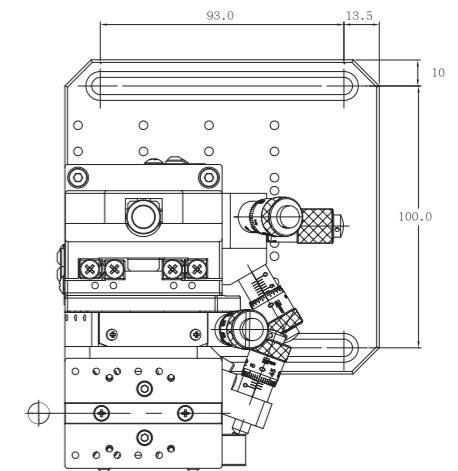
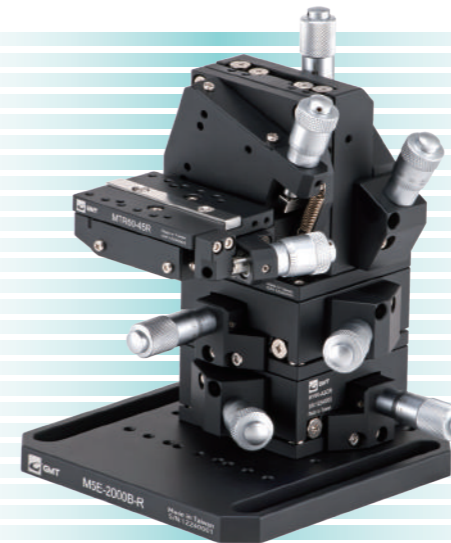

### M5E-2000B-R

Specification / Axis	Travel Stroke		Resolution	
	Coarse Tuning	Fine Tuning	Coarse Tuning	Fine Tuning
X	±6.5mm	±0.3mm	10um	0.5um
Y	±6.5mm	±0.3mm	10um	0.5um
Z	±6.5mm	±0.3mm	10um	0.5um
θx	±3° mm		≅ 29.3"/div.	
θy	±3° mm		≅ 27.8"/div.	

M5E-2000S model is consisted XYZ manual positioning stages assembled with tilt stage (θx, θy) to perform a unit with 5-axis high resolution positioning stage.  
The complete assembly is mostly applied to single-fiber alignment equipment.

Remark: Available option of XYZ module with ordering code: MXYZ60-ACSR;  
Tilt module with ordering code: MTR60-45R

## Hi-Resolution Positioning Stage Left hand tuning

### M6E-2200B-L

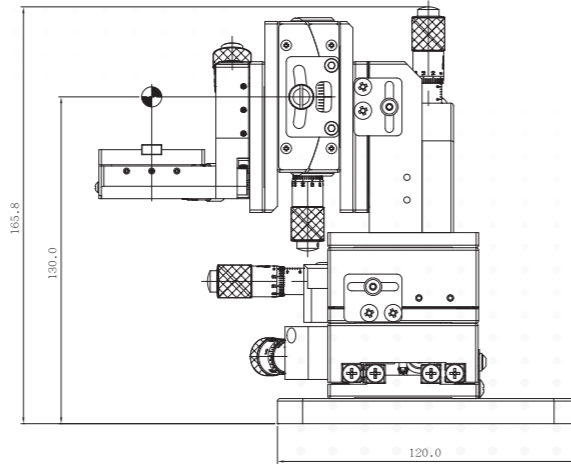
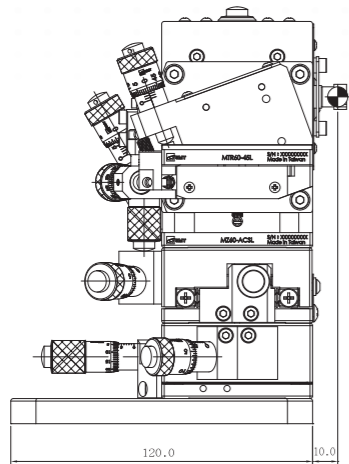
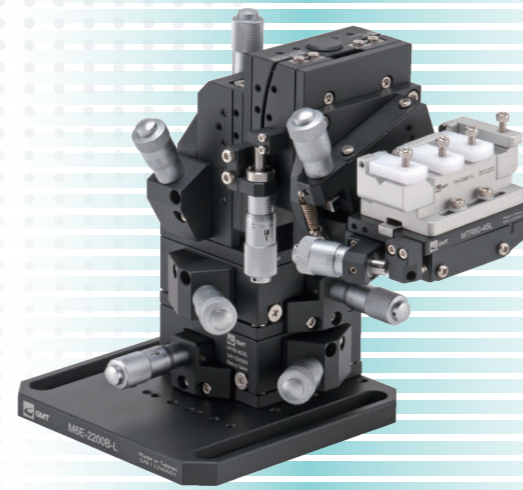
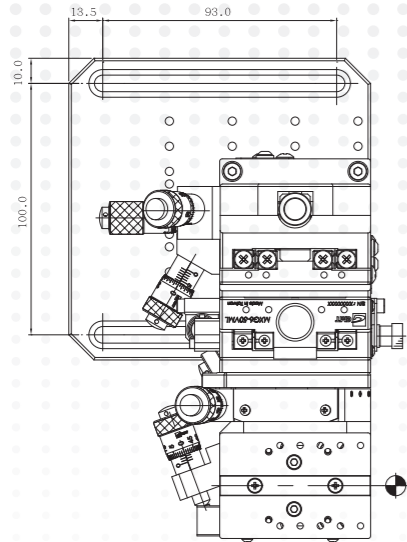

### M6E-2200B-L

Specification Axis	Travel Stroke		Resolution	
	Coarse Tuning	Fine Tuning	Coarse Tuning	Fine Tuning
X	±6.5mm	±0.3mm	10um	0.5um
Y	±6.5mm	±0.3mm	10um	0.5um
Z	±6.5mm	±0.3mm	10um	0.5um
θx	±3°mm		≅ 29.3"/div.	
θy	±3°mm		≅ 27.8"/div.	
θz	±4°mm		≅ 33"/div.	

M6E-2000S model is consisted XYZ manual positioning stages assembled with tilt stage and goniometer stage to perform a unit with 6-axis high resolution positioning stage.  
The complete assembly is mostly applied to multi-core-fiber equipment for rotary adjustment of optical axis in optical fiber and optical waveguide industry.

Remark: Available option of XYZ module with ordering code: MXYZ60-ACSL;  
Goniometer module with ordering code: MXG6-50VML  
Tilt module with ordering code: MTR60-45L

## Hi-Resolution Positioning Stage Right hand tuning

### M6E-2200B-R

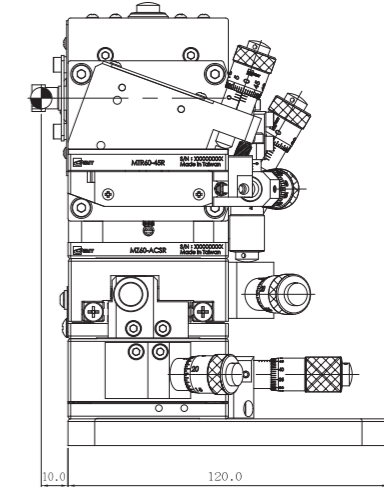
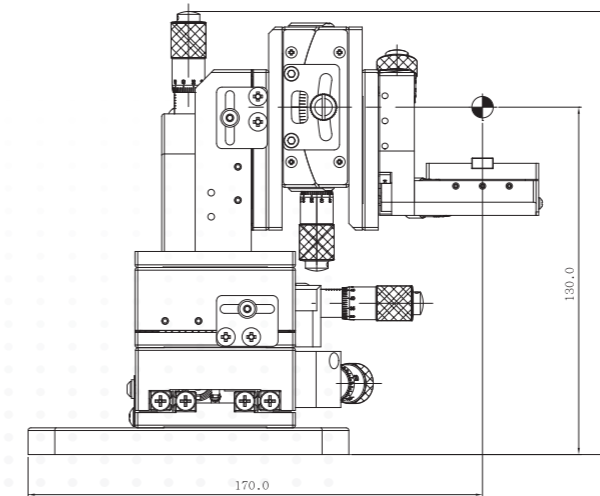
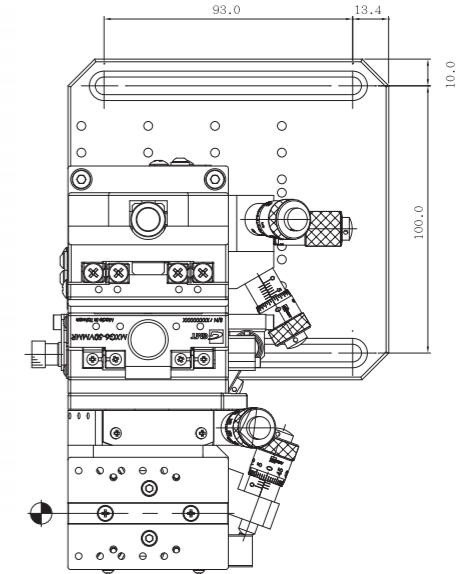
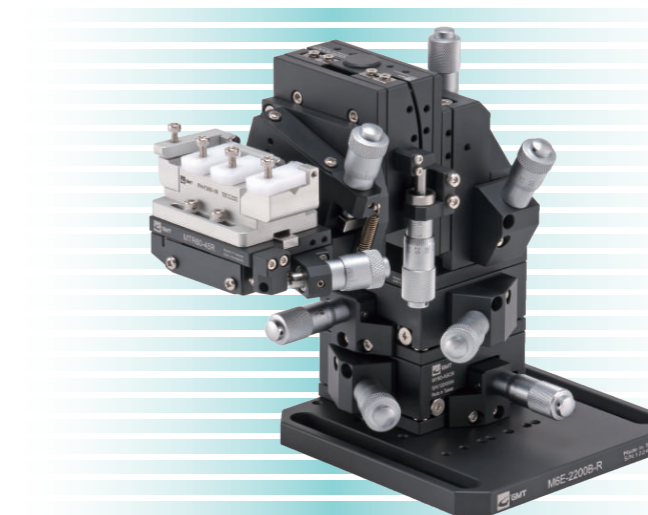

### M6E-2200B-R

Specification Axis	Travel Stroke		Resolution	
	Coarse Tuning	Fine Tuning	Coarse Tuning	Fine Tuning
X	±6.5mm	±0.3mm	10um	0.5um
Y	±6.5mm	±0.3mm	10um	0.5um
Z	±6.5mm	±0.3mm	10um	0.5um
θx	±3°mm		≅ 29.3"/div.	
θy	±3°mm		≅ 27.8"/div.	
θz	±4°mm		≅ 33"/div.	

M6E-2000S model is consisted XYZ manual positioning stages assembled with tilt stage and goniometer stage to perform a unit with 6-axis high resolution positioning stage.  
The complete assembly is mostly applied to multi-core-fiber equipment for rotary adjustment of optical axis in optical fiber and optical waveguide industry.

Remark: Available option of XYZ module with ordering code: MXYZ60-ACSR;  
Goniometer module with ordering code: MXG6-50VMR  
Tilt module with ordering code: MTR60-45R



# Hi-Resolution Positioning Stage Left hand tuning

## M5F-M460A561-L

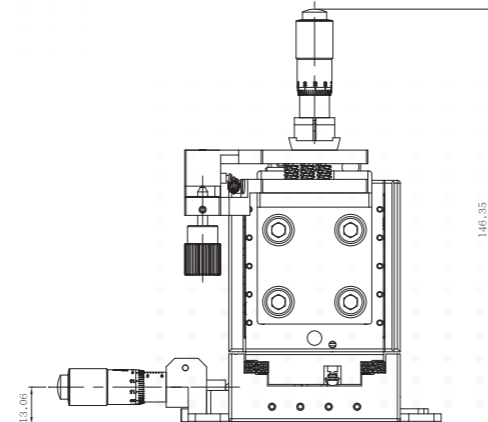
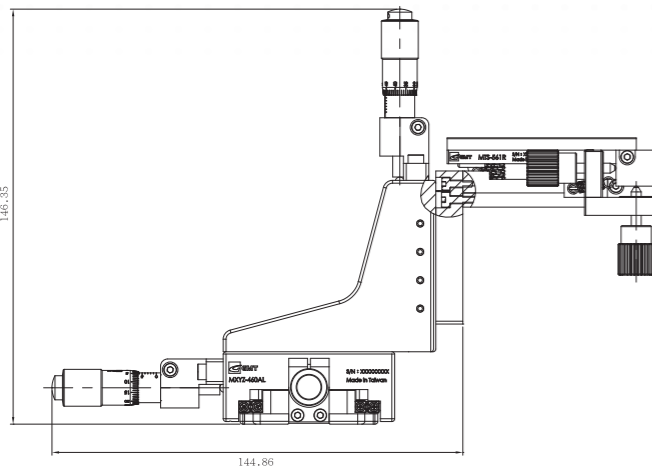
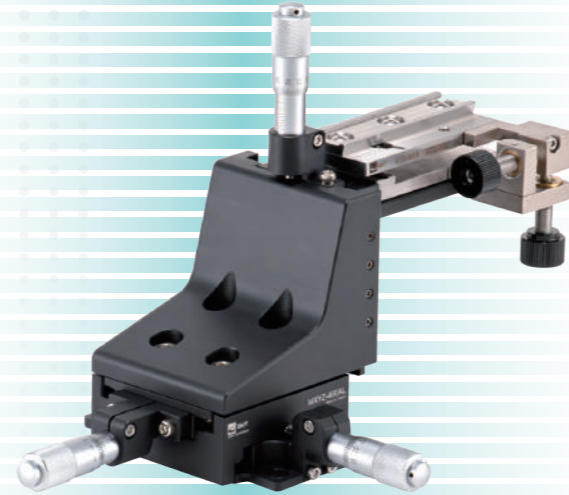
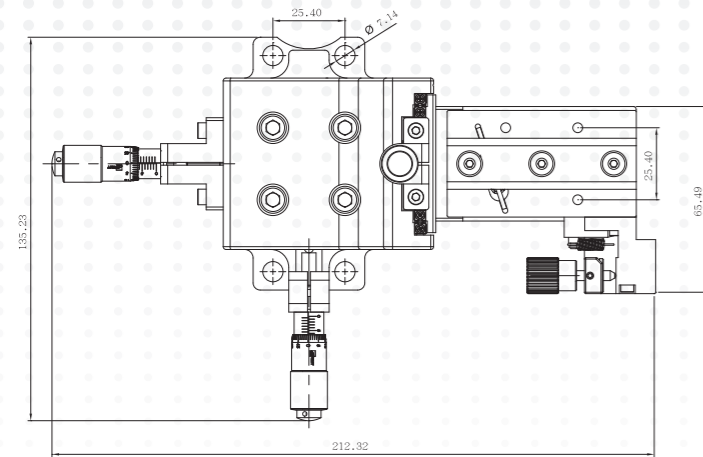

## M5F-M460A561-L

Specification	Travel Stroke	Allowable(N)	Material
X	0.5 inch.(12.7mm)	67	Aluminum alloy
Y	0.5 inch.(12.7mm)		
Z	0.5 inch.(12.7mm)		
θx	±5°	Stainless Steel	
θy	±5°		

Thread hole	Size [ inch.(mm) ]		
A	B	C	
1/4-20	0.5(12.5)	1(25.4)	

M5F-M460A561-L model is consisted of XYZ manual positioning stages, assembled with tilt-stage (θX,θY), to perform a unit with 5-axis high resolution positioning stage.

Remark : Available option of XYZ model with ordering code MXYZ460-AL  
Tilt module with ordering code : MTS-561-L

# Hi-Resolution Positioning Stage Right hand tuning

## M5F-M460A561-R

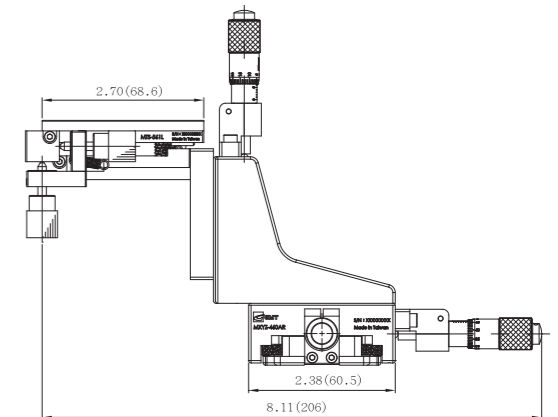
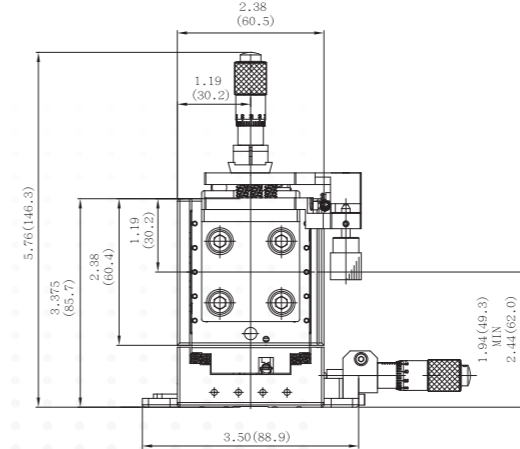
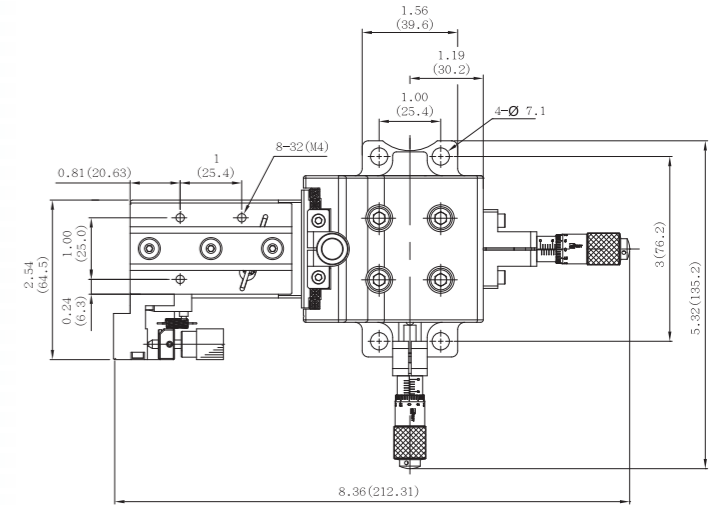
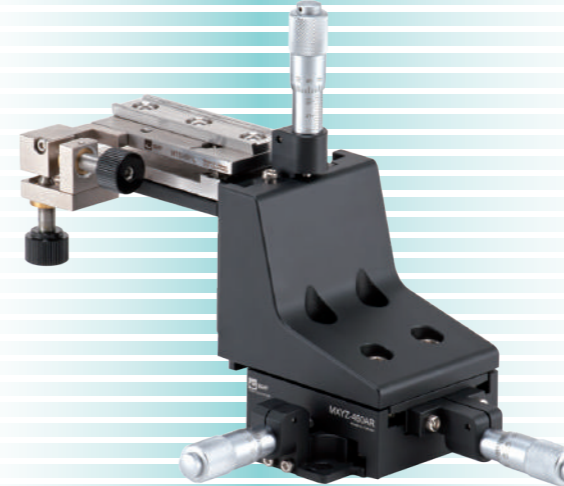

## M5F-M460A561-R

Specification	Travel Stroke	Allowable(N)	Material
X	0.5 inch.(12.7mm)	67	Aluminum alloy
Y	0.5 inch.(12.7mm)		
Z	0.5 inch.(12.7mm)		
θx	±5°	Stainless Steel	
θy	±5°		

Thread hole	Size [ inch.(mm) ]		
A	B	C	
1/4-20	0.5(12.5)	1(25.4)	

M5F-M460A561-R model is consisted of XYZ manual positioning stages, assembled with tilt-stage (θX,θY), to perform a unit with 5-axis high resolution positioning stage.

Remark : Available option of XYZ model with ordering code MXYZ460-AR  
Tilt module with ordering code : MTS-561-R

# Hi-Resolution Positioning Stage Left hand tuning

## MTS-561-L

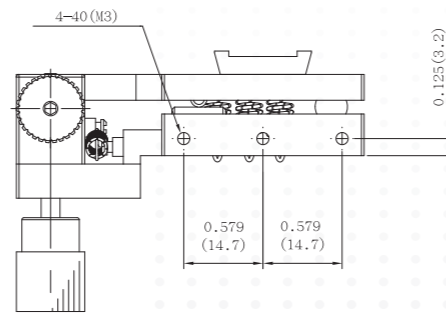
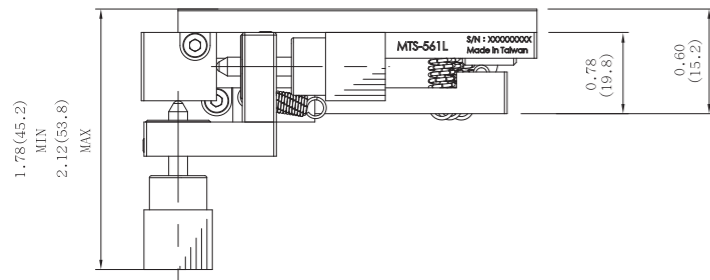
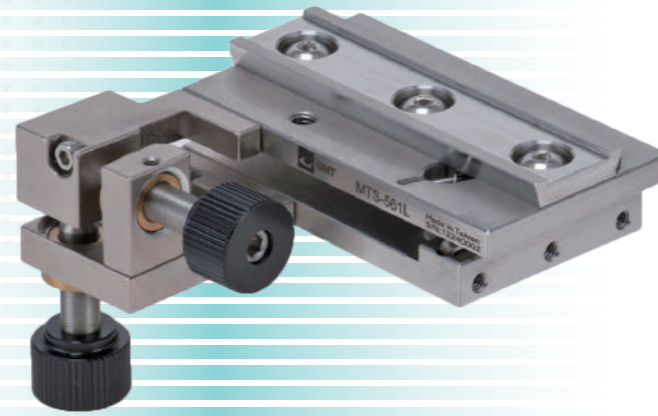
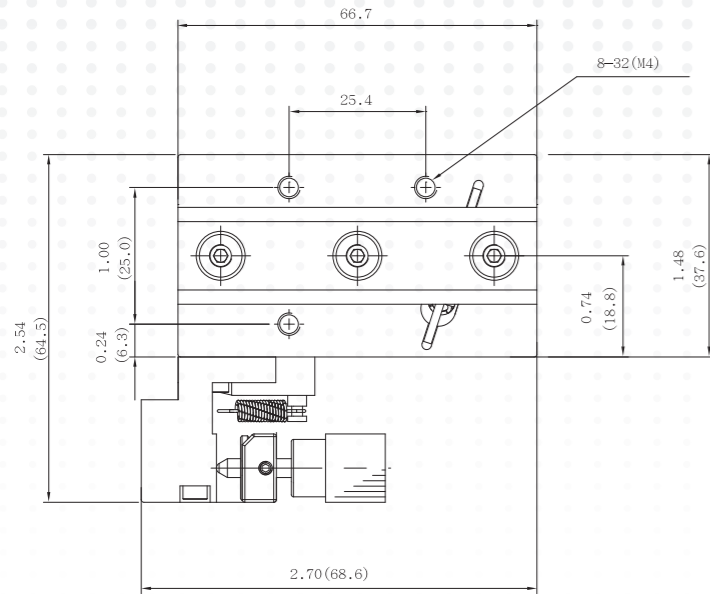

## MTS-561-L

Specification	Travel Stroke	Sensitivity	Allowable(N)	Material
Axis				
$\theta_x$	$\pm 5^\circ$	Each circular motion 5arc-seconds	22	Stainless Steel
$\theta_y$	$\pm 5^\circ$			

Tilt stage model MTS-561-L body is stainless steel, which obtains an excellent stability under long-time working process. The 5arc-second sensitivity could make the positioning adjustment much simpler and easier.

# Hi-Resolution Positioning Stage Right hand tuning

## MTS-561-R

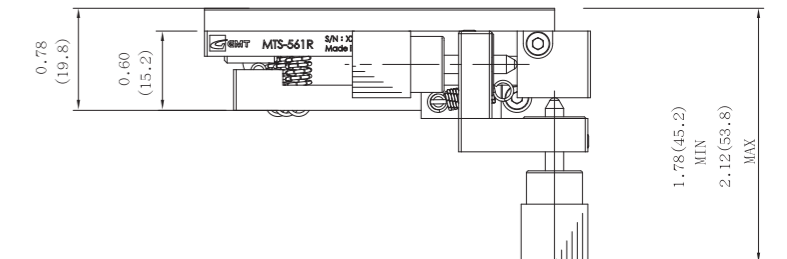
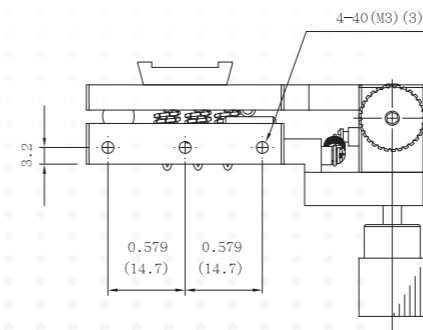
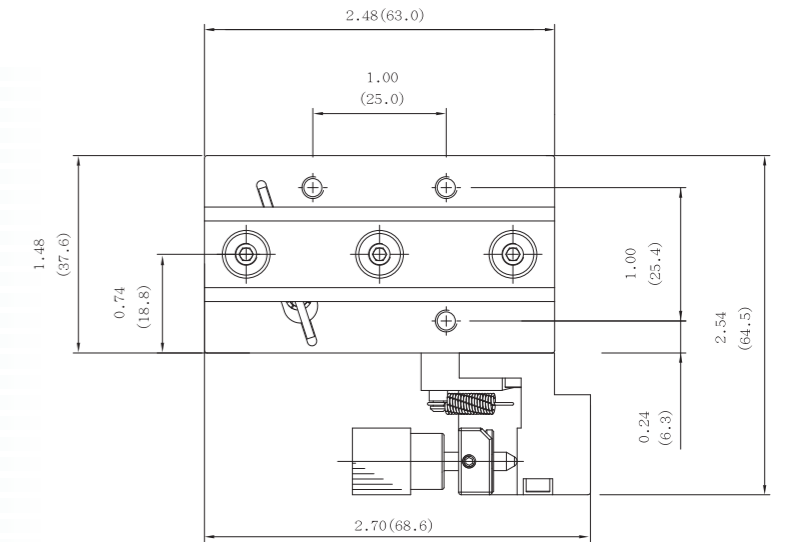
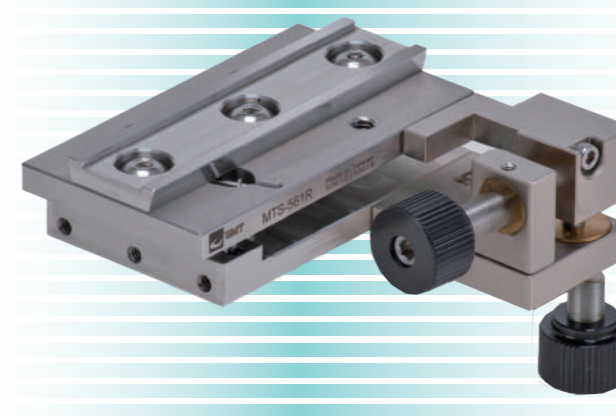

## MTS-561-R

Specification	Travel Stroke	Sensitivity	Allowable(N)	Material
Axis				
$\theta_x$	$\pm 5^\circ$	Each circular motion 5arc-seconds	22	Stainless Steel
$\theta_y$	$\pm 5^\circ$			

Tilt stage model MTS-561-R body is stainless steel, which obtains an excellent stability under long-time working process. The 5arc-second sensitivity could make the positioning adjustment much simpler and easier.

# Hi-Resolution Positioning Stage Left hand tuning

## MXY-460AL

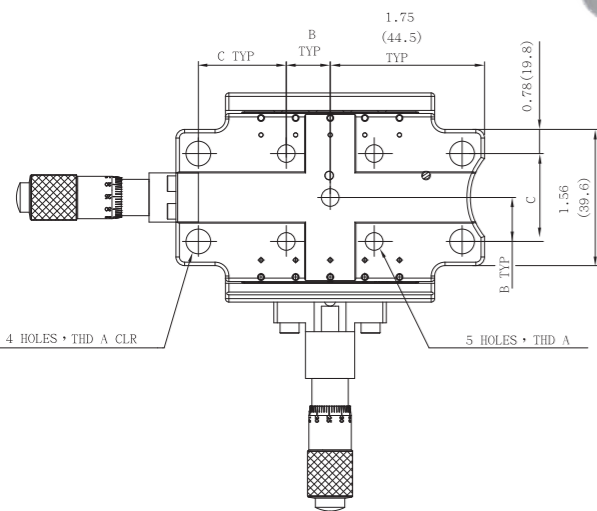
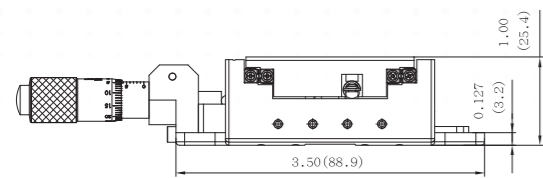
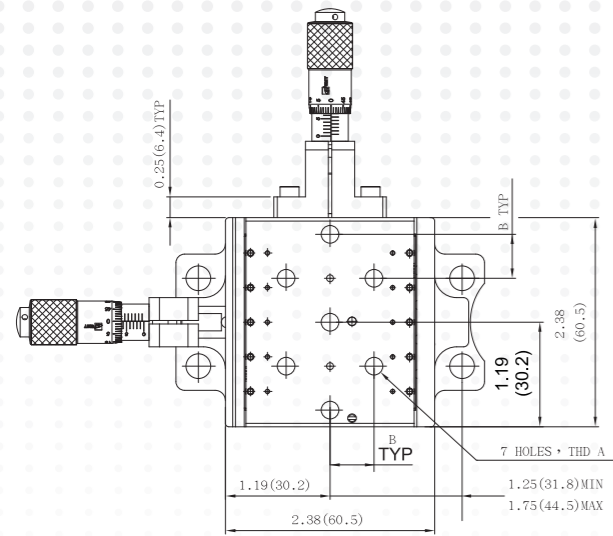

Thread hole	Size [ inch.(mm) ]		
	A	B	C
1/4-20	0.5(12.5)	1(25.4)	

## MXY-460AL

Specification	Travel Stroke	Resolution	Allowable(N)	Material
Axis X	0.5 inch(12.7mm)	10um	67	Stainless Steel
Axis Y	0.5 inch(12.7mm)			

Aluminum Alloy made stage MXY460A-L with its spectacular feature of composing of GMT crossed roller slide rail set, which obtains the advantages of roller transmission of heavy loading capacity and reliability.

# Hi-Resolution Positioning Stage Right hand tuning

## MXY-460AR

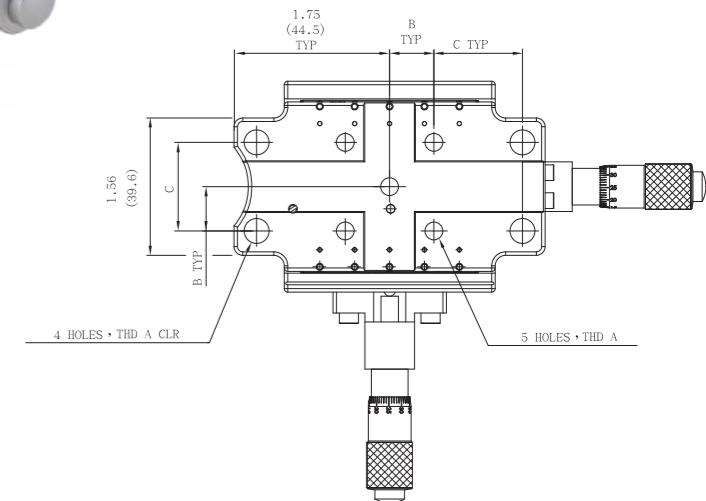
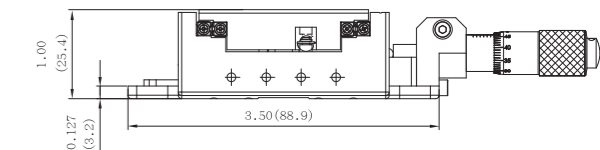
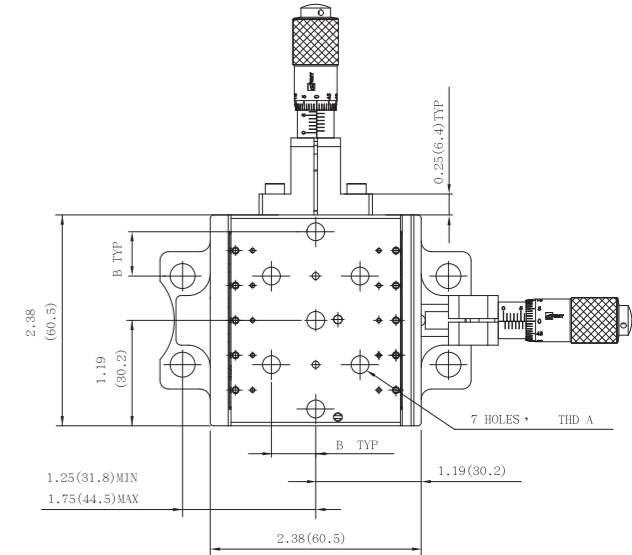

Thread hole	Size [ inch.(mm) ]		
	A	B	C
1/4-20	0.5(12.5)	1(25.4)	

## MXY-460AR

Specification	Travel Stroke	Resolution	Allowable(N)	Material
Axis X	0.5 inch(12.7mm)	10um	67	Stainless Steel
Axis Y	0.5 inch(12.7mm)			

Aluminum Alloy made stage MXY460A-R with its spectacular feature of composing of GMT crossed roller slide rail set, which obtains the advantages of roller transmission of heavy loading capacity and reliability.



# Hi-Resolution Positioning Stage Left hand tuning

## MXYZ-460AL

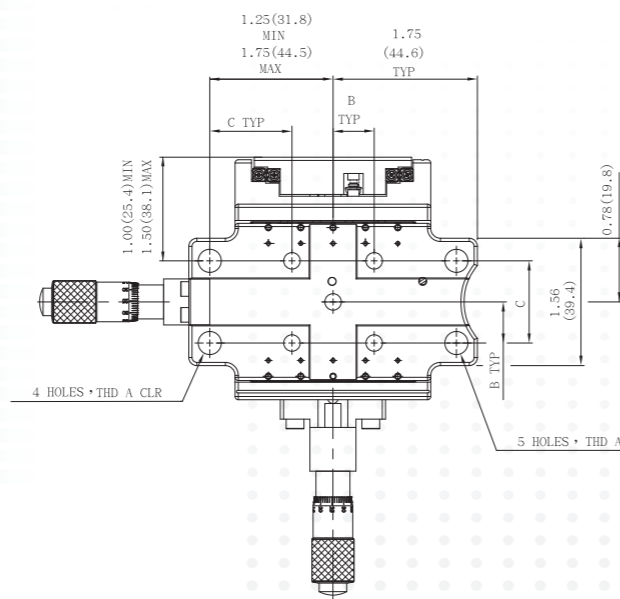
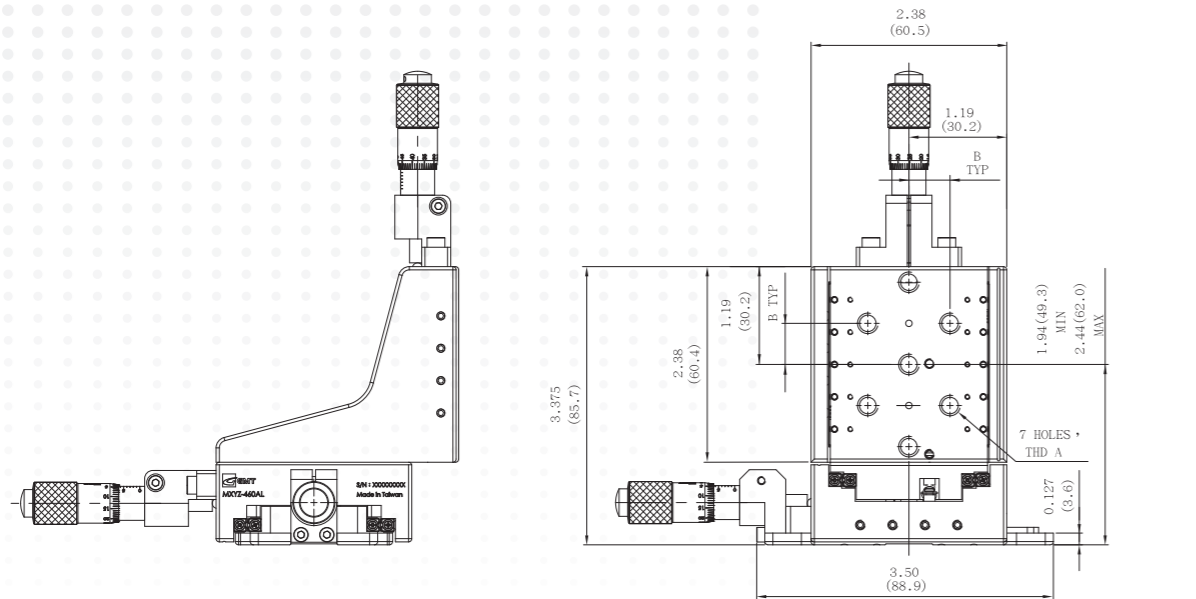

Thread hole	Size [ inch.(mm) ]		
	A	B	C
1/4-20	0.5(12.5)	1(25.4)	

## MXYZ-460AL

Axis	Specification	Travel Stroke	Resolution	Allowable(N)	Material
X		0.5(inch)12.7mm	10um	67	Stainless Steel
Y		0.5(inch)12.7mm			
Z		0.5(inch)12.7mm			

The Triple-Axis precision stage MXYZ460A-L frame is Aluminum Alloy, and the spectacular feature is the composing of GMT cross roller slide rail set. In addition, this Triple-Axis stage could also be taken apart and re-assembled to a XY-axis stage or even a XZ-axis stage.

# Hi-Resolution Positioning Stage Right hand tuning

## MXYZ-460AR

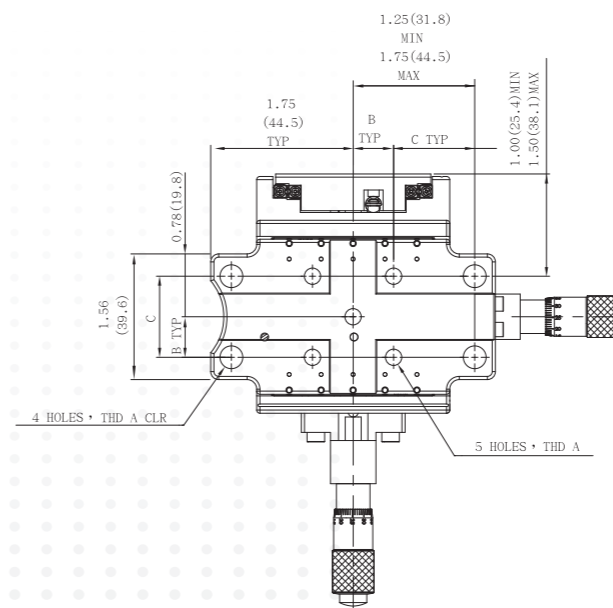
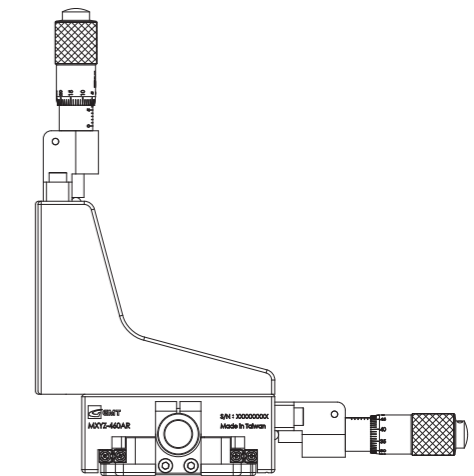
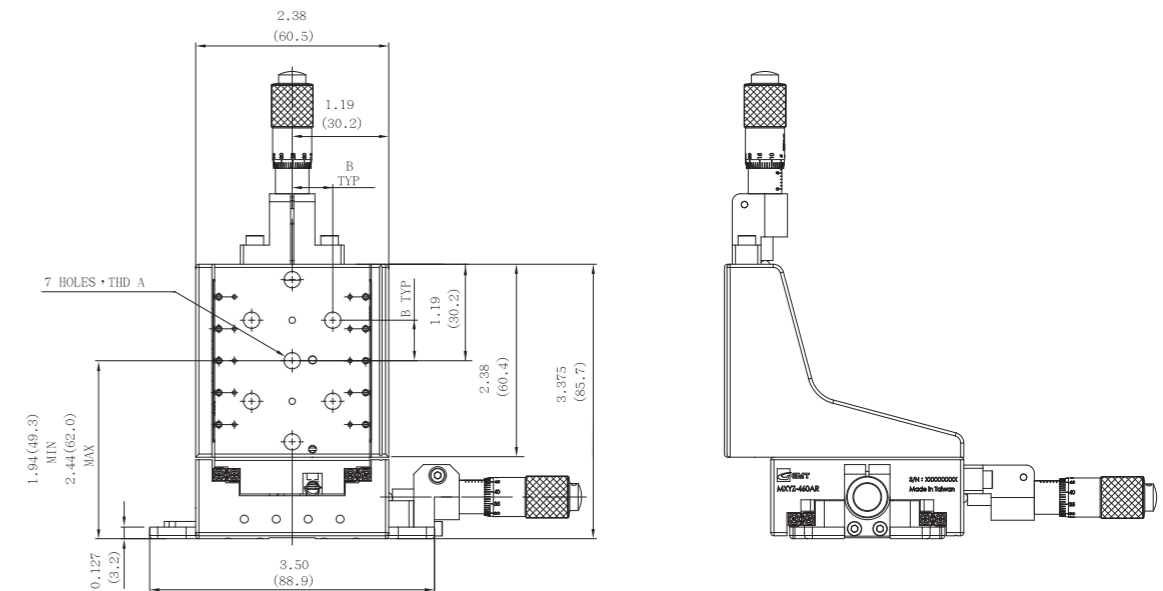

Thread hole	Size [ inch.(mm) ]		
	A	B	C
1/4-20	0.5(12.5)	1(25.4)	

## MXYZ-460AR

Axis	Specification	Travel Stroke	Resolution	Allowable(N)	Material
X		0.5(inch)12.7mm	10um	67	Stainless Steel
Y		0.5(inch)12.7mm			
Z		0.5(inch)12.7mm			

The Triple-Axis precision stage MXYZ460A-R frame is Aluminum Alloy, and the spectacular feature is the composing of GMT cross roller slide rail set. In addition, this Triple-Axis stage could also be taken apart and re-assembled to a XY-axis stage or even a XZ-axis stage.



## Advantages of cryogenic process

All **GMT** Hi-Resolution Positioning Stage is well been cryogenic processing.

Cryogenic process is to place the part in the medium with temperature under 196 °C, followed step by step progress of new technic to improve material character. Found by relevant search, cryogenic process is not only obviously increase on strength and life of black (colour)metal, plastic and china...etc, but also improve the structure evenly. Increase of dimension stability brings huge economic benefit and promising application in aviation 、 aerospace 、 optics 、 creatures 、 chemistry 、 machinery, electronic and light industry.

### ◆ Purpose of cryogenic process

Improving physical character (mechanical character) of metal or other material by progress of subzero processing, to raise usage life, efficiency and quality of parts or workpiece.

Ex: Comparison of metallographic analysis

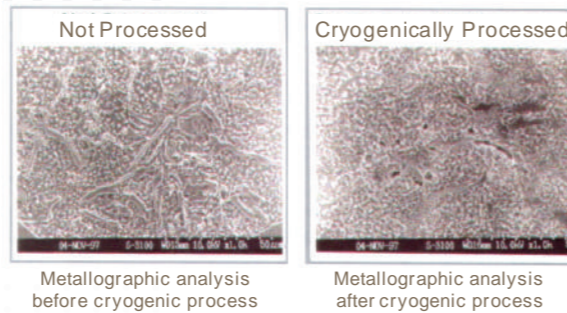

### ◆ Benefic analysis of aluminum alloy after cryogenic process:

Improvement during process or in the end of process:

- (1) Deformation of microstructure stress caused by designed material shape.
- (2) Effectively controlling aging deformation.
- (3) After mechanical testing, mechanism strength has been obviously improved, and perfectly perform the desinged mechanism.

Practical application : After dissolving aluminum alloy(Duralumin),have it with cryogenic process and unfrozen immediately. It could not only speed up aging, but reduce most of residual stress at same time to improve mechanical character. Found by another info, aluminum alloy casting with cryogenic process has improvement of processed ability.

Material	Parts	Hardness	Durability	Processing life	Dimension stability	Others
SKH	Drill, Cutting, Tools	+	+	+	+	1 time temper
SKD11	Blanking Die, Punch, Cutting Blade Roller	+	+	+	+	Avoid broken by grinding
SKD61	Aluminum extrusion die	+	+			
SUJ	Rail, Roll Guide	+	+		+	
Inner parts	Bearing, Gear, Bushing, Cam	+	+		+	Avoid broken by grinding
SUS	Austenite (300 )	+	+		+	Improvement of corrosion resistance
	Martensitic(420J2 ,440 )	+	+		+	
	Separated (300 ,631 )	+	+	+	+	
18Ni 280Grade	18%Ni type	+	+		+	Speed up sging
	25%Ni type	+	+		+	Speed up sging
Sintering alloy	Cutting tools ,Roller ,Automobile parts		+	+	+	Reduce residual stress
Cu alloy	Electrode , Fire gate					
AL alloy	Automatic machinery , precision processing , die manufacture , electronic and precision instrument , SMT、 PC board soldering device		+		+	Improvement of processed ability