

# LT60S SERIES

Compact linear units  
with internal rail guide

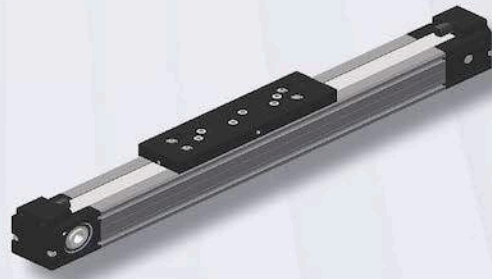

- Compact design, the width of the profile 60 mm
- Internal recirculating ball rail guide size -15 -
- Double carriage design for heavier loads
- Toothed belt type 25 AT5
- Advanced internal lubrication system

## TECHNICAL DATA

## LT60STR-S15D

Maximum stroke length	mm	5.750
Maximum speed	mm/s	3.000
Maximum acceleration	m/s <sup>2</sup>	30
No load torque	Nm	0,6
Repeatability	mm	± 0,1
Movement per revolution	mm	150

# LT60S-TR-S15D

## TECHNICAL DATA

LOAD CAPACITY		LT60S-TR-S15D	LT60S-TR-S15D****L
Mx	Nm	128	172
My	Nm	128	172
Mz	Nm	40	40
Fx	N	1.200	1.200
Fy	N	3.400	3.400
Fz	N	3.600	3.600

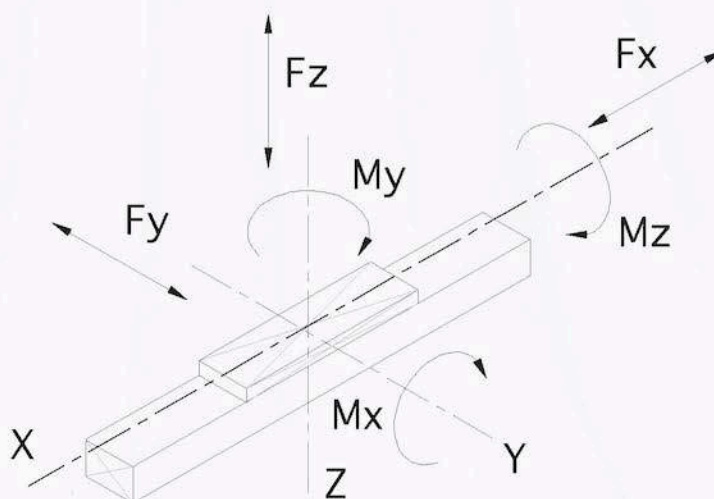

## WEIGHTS (KG)

	LT60S-TR-S15D	LT60S-TR-S15D****L
Unit weight 0 mm stroke	3,69	4,09
Weight per 100 mm stroke	0,40	0,40
Mass of carriage	0,98	1,38

# LT60S-TR-S15D

## DIMENSIONS

### DIMENSIONS LT60S-TR-S15D

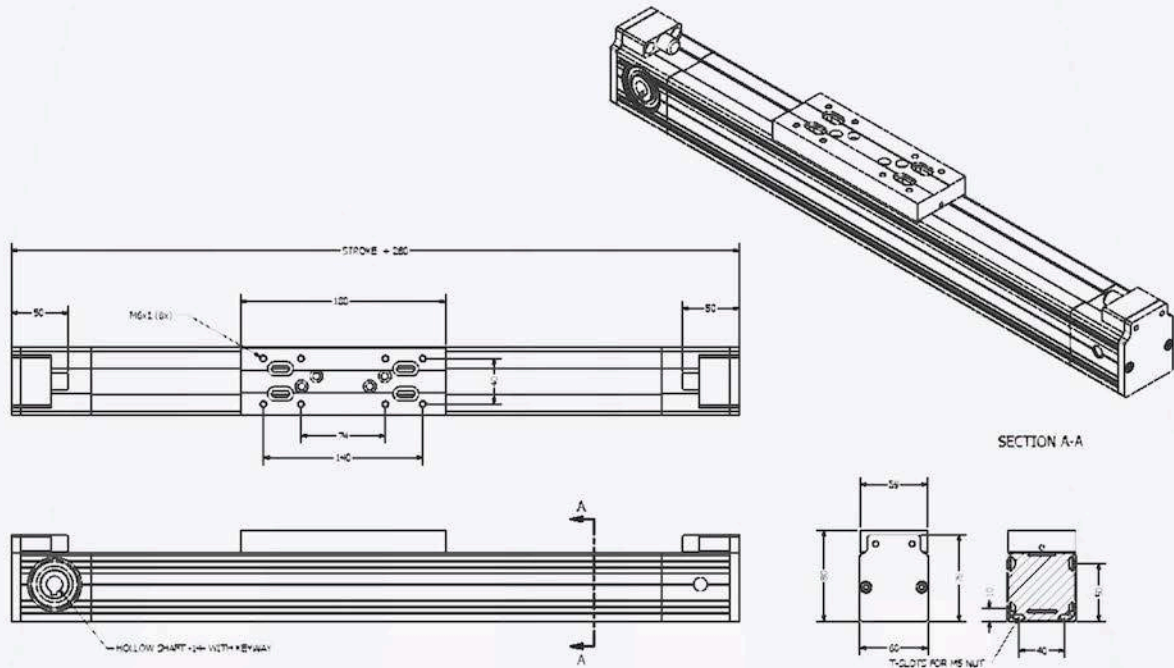

### DIMENSIONS LT60S-TR-S15D-\*\*\*\*L

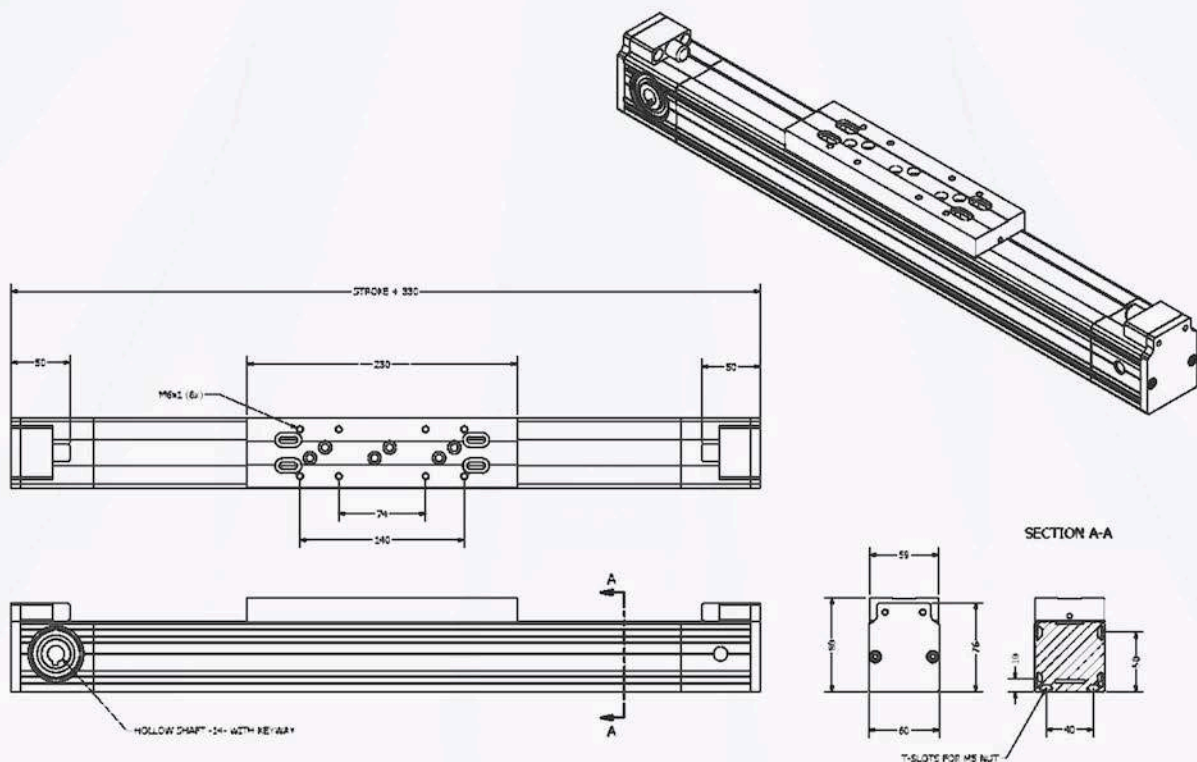

# LT60S-TR-S15D

## MOTOR ACCESSORIES

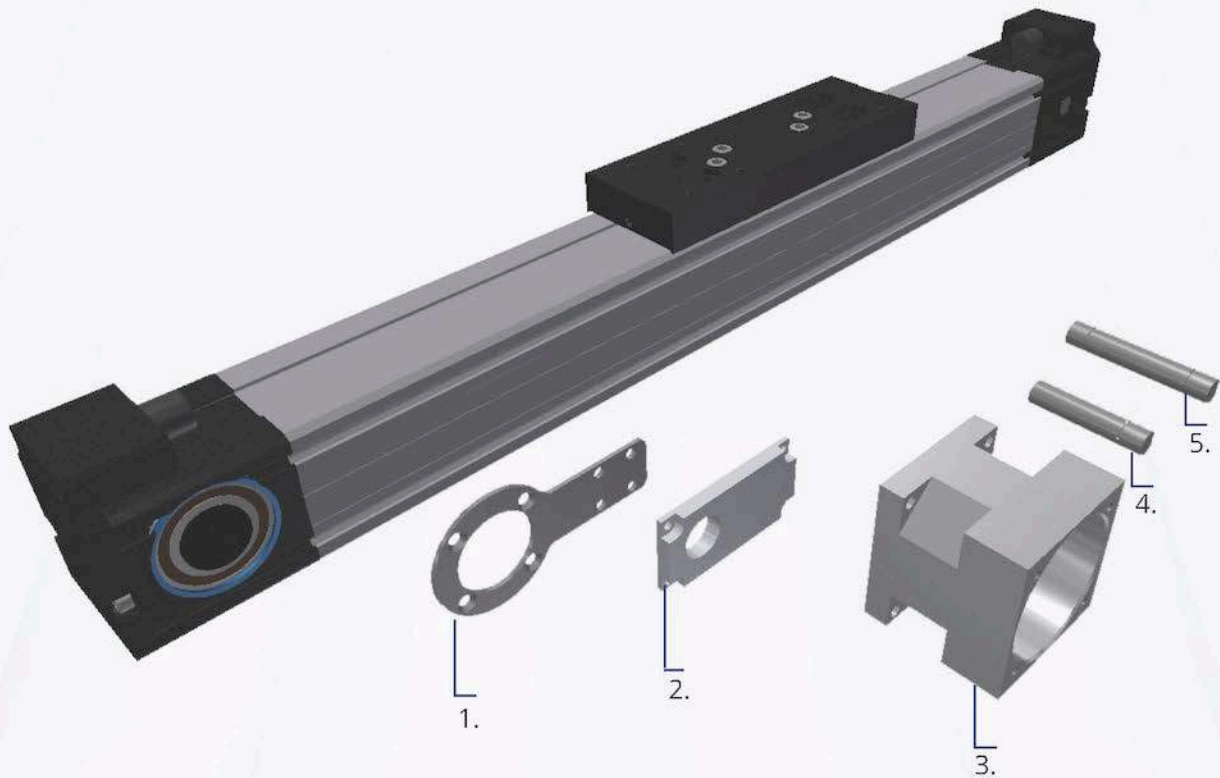

1	60S70-RA-M-XXX	Motor adaptor armtype
2	60S70-F-XXX	Motor Flange
3	60S70-FL-XXX	Motor adaptor
4	60S70-SS-16-GS19	Single shaft $\varnothing$ 16
5	60S70-DS-16-GS19	Double shaft $\varnothing$ 16



# LT60S-TR-S15D

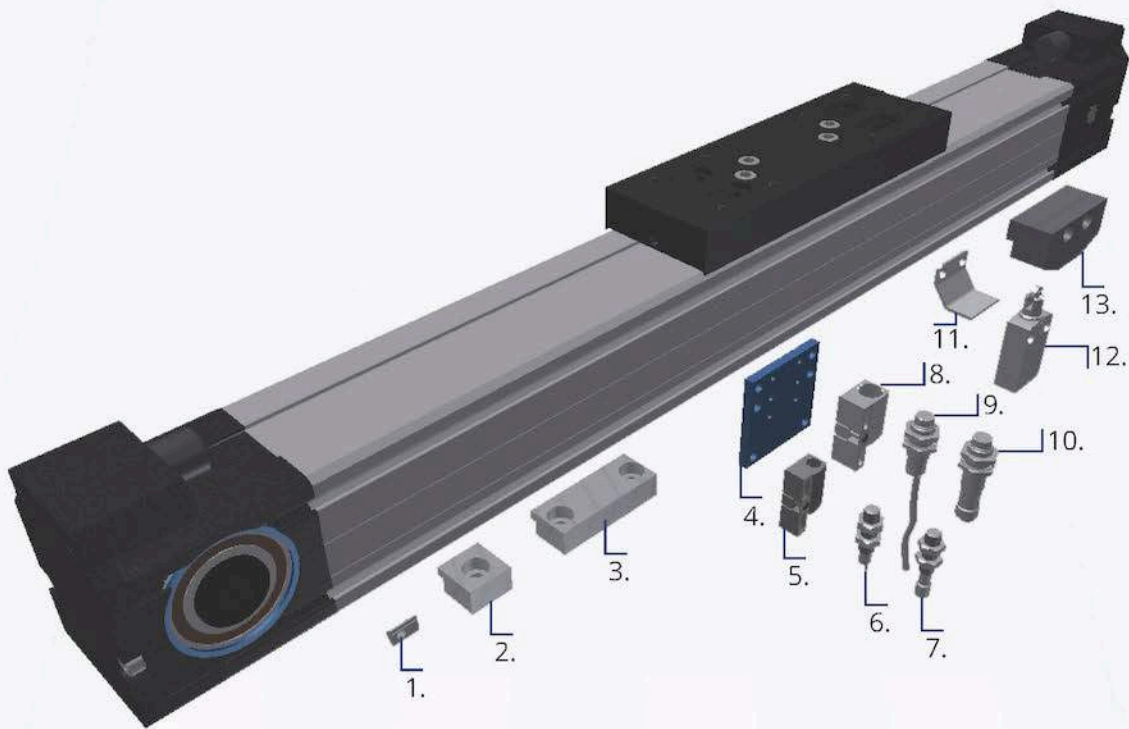

1	111-012	Singel Nut M5
2	60S121	Clamping plate single
3	60S122	Clamping plate double
4	60S70-SH-XS	Bracket for Telem. bracket
5	XSZB108	Bracket for M8 sensor
6	XS05B1PAL2	M8 inductive sensor-cable
7	XS508B1PAM8	M8 inductive sensor-M8
8	XSZB112	Bracket for M12 sensor
9	XS212b4pal	M12 inductive sensor-cable
10	XS212b4pbm	M12 inductive sensor-M8
11	5570-DB4-IN	Sensor Bracket
12	ASV1-C525	Reed switch
13	5570-SD-ME	Switch bracket