

LTZ55 SERIES

Compact linear units with
internal rail guide

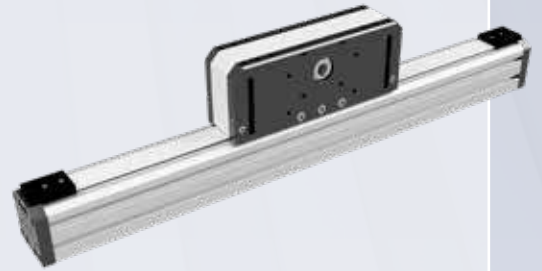

- Compact design, the width of the profile 55 mm
- Internal recirculating ball rail guide size -15 -
- Double carriage design for heavier loads
- Toothed belt type 25 AT5

TECHNICAL DATA

LTZ55-TR-S15D

Maximum stroke length	mm	3.000
Maximum speed	mm/s	3.000
Maximum acceleration	m/s ²	30
No load torque	Nm	1,2
Max. driving torque	mm	14
Repeatability	mm	± 0,1
Movement per revolution		150

LTZ55 SERIES

TECHNICAL DATA

LOAD CAPACITY

LTZ55-TR-S15D

Mx	Nm	120
My	Nm	120
Mz	Nm	40
Fx	N	1.200
Fy	N	3.400
Fz	N	3.600

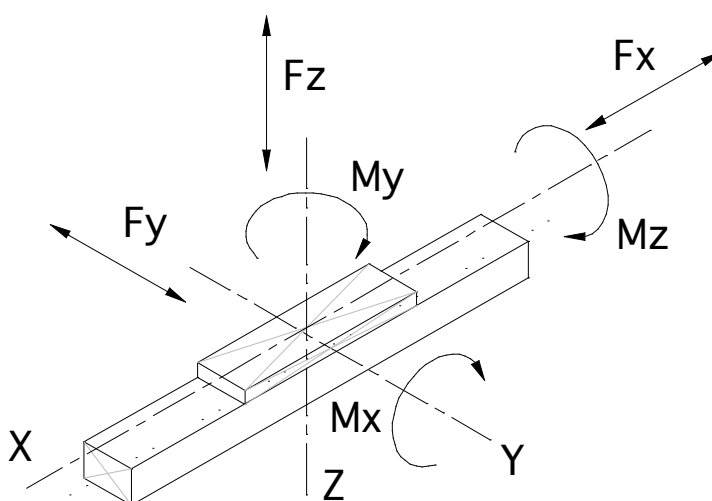

WEIGHTS (KG)

LTZ55-TR-S15D

Unit weight 0 mm stroke	4,90
Weight per 100 mm stroke	0,40

LTZ55 SERIES

DIMENSIONS LTZ55-TR-S15D

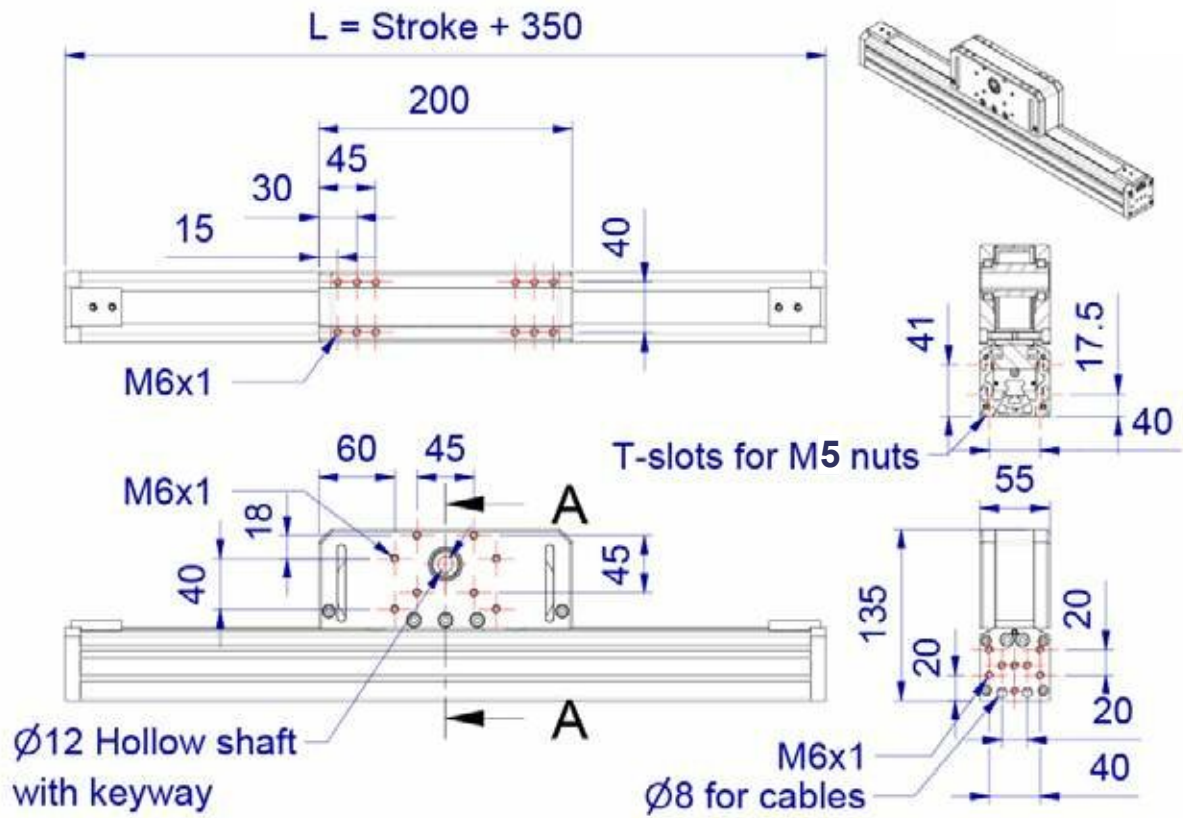

All drawings can be downloaded from www.almotion.nl