

Flanschwagen der Bauart SS-JMZ und SS-EMZ

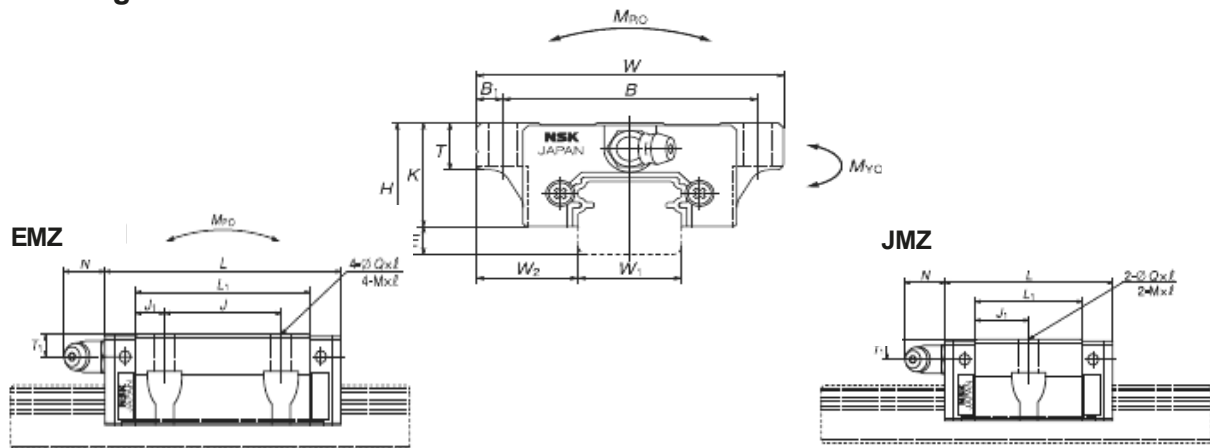

Modell-Nr.	Einbau-maße			Wagenabmessungen											Schmier-anschluß		
	H	E	W ₂	W	L	B	J	QxL	MxSteig.xL	B ₁	L ₁	J ₁	K	T	T ₁	N	
JMZ					40,4	—					23,6	11,8					
SAS15	24	4,6	18,5	52		41		4,4x7	M5x0,8x7	5,5			19,4	8	3	6	3
EMZ					56,8	26					40	7					
JMZ					47,2	—					30	15					
SAS20	28	6	19,5	59		49		5,3x9	M6x1x9	5			22	10	M6x0,75	5,5	11
EMZ					65,2	32					48	8					
JMZ					59,6	—					38	19					
SAS25	33	7	25	73		60		6,8x10	M8x1,25x10	6,5			26	11	M6x0,75	7	11
EMZ					81,6	35					60	12,5		(12)			
JMZ					67,4	—					42	21					
SAS30	42	9	31	90		72		8,6x12	M10x1,5x12	9			33	11	M6x0,75	8	11
EMZ					96,4	40					71	15,5		(15)			
JMZ					77	—					49	24,5					
SAS35	48	10,5	33	100		82		8,6x13	M10x1,5x13	9			37,5	12	M6x0,75	8,5	11
EMZ					108	50					80	15		(15)			

Tragzahlen		zul.stat.Kipp-moment			Kugel-Ø	Gewicht		Wagen-länge m.	Modell-Nr.
C _{dyn.}	C _{0stat.}	M _{RO}	M _{PO}	M _{YO}	D _w	Wag.	Sch.	2xK1™	
[N]	[N]	[Nm]	[Nm]	[Nm]	[mm]	[kg]	[kg/m]	[mm]	
4.900	7.800	39	21	18		0,17	1,4	50	JMZ
					2,78				SAS15
7.900	15.600	78	74	62		0,26		66,4	EMZ
7.250	11.800	80	41	34		0,24		57,8	JMZ
					3,18		2,3		SAS20
11.100	21.800	149	124	104		0,35		75,8	EMZ
12.700	20.800	164	97	81		0,44		70,2	JMZ
					3,97		3,1		SAS25
17.900	33.500	266	242	203		0,66		92,2	EMZ
18.700	29.600	282	153	128		0,76		79,4	JMZ
					4,76		4,8		SAS30
27.300	50.500	480	415	350		1,2		108,4	EMZ
26.000	40.000	465	234	196		1,2		90	JMZ
					5,56		7		SAS35
38.000	68.500	800	620	520		1,7		121	EMZ

Type JMZ auf Anfrage

Blockwagen der Bauart SS-ALZ und SS-CLZ

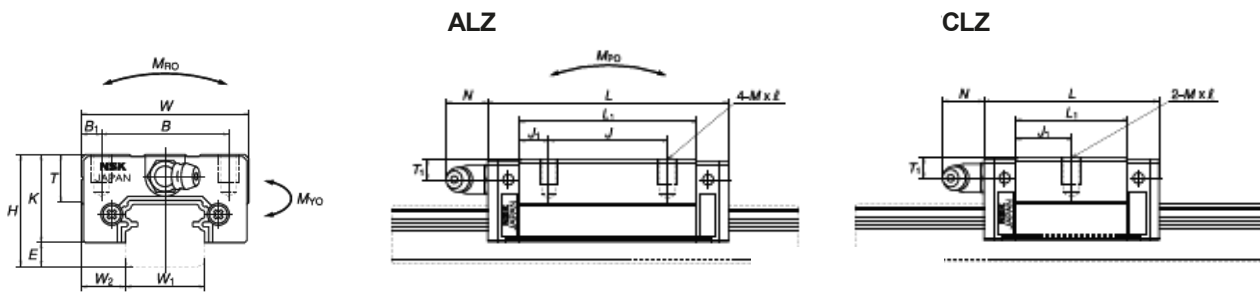

Modell-Nr.	Einbaumaße			Wagenabmessungen										Schmieranschluß	
	H	E	W ₂	W	L	B	J	MxSteig.xℓ	B ₁	L ₁	J ₁	K	T	T ₁	N
CLZ					40,4		—			23,6	11,8				
SAS15	24	4,6	9,5	34		26		M4x0,7x6	4			19,4	10	3	6
ALZ					56,8		26			40	7				
CLZ					47,2		—			30	15				
SAS20	28	6	11	42		32		M5x0,8x7	5			22	12	M6x0,75	5,5
ALZ					65,2		32			48	8				
CLZ					59,6		—			38	19				
SAS25	33	7	12,5	48		35		M6x1 x9	6,5			26	12	M6x0,75	7
ALZ					81,6		35			60	12,5				
CLZ					67,4		—			42	21				
SAS30	42	9	16	60		40		M8x1,25x12	10			33	13	M6x0,75	8
ALZ					96,4		40			71	15,5				
CLZ					77		—			49	24,5				
SAS35	48	10,5	18	70		50		M8x1,25x12	10			37,5	14	M6x0,75	8,5
ALZ					108		50			80	15				

Tragzahlen		zul.stat.Kippmoment			Kugel-Ø	Gewicht		Wagenlänge m.	Modell-Nr.
C _{dyn.}	C _{0stat.}	M _{RO}	M _{PO}	M _{YO}	D _w	Wag.	Sch.	2xK1™	
[N]	[N]	[Nm]			[mm]	[kg]	[kg/m]	[mm]	
4.900	7.800	39	21	18		0,14		50	CLZ
					2,78		1,4		SAS15
7.900	15.600	78	74	62		0,2		66,4	ALZ
7.250	11.800	80	41	34		0,19		57,8	CLZ
					3,18		2,3		SAS20
11.100	21.800	149	124	104		0,28		75,8	ALZ
12.700	20.800	164	97	81		0,34		70,2	CLZ
					3,97		3,1		SAS25
17.900	33.500	266	242	203		0,51		92,2	ALZ
18.700	29.600	282	153	128		0,58		67,4	CLZ
					4,76		4,8		SAS30
27.300	50.500	480	415	350		0,85		79,4	ALZ
26.000	40.000	465	234	196		0,86		90	CLZ
					5,56		7		SAS35
38.000	68.500	800	620	520		1,3		121	ALZ