

IKO

**C-Lube Linear Way ME
Linear Way E**

ALMOTION

ME • LWE

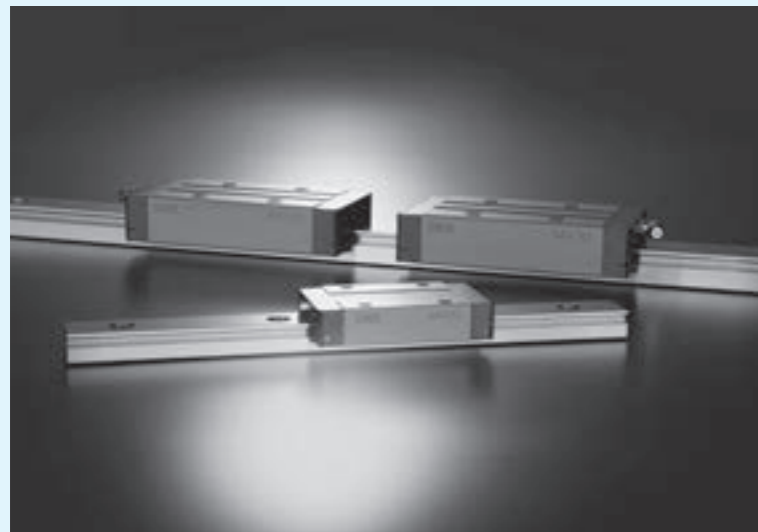

C-Lube Linear Way ME



ME



Points

1 Compact and versatile series with utility

Versatile linear motion rolling guide that has achieved utility pursuing compactness in every aspect.

2 Wide range of variations for your needs

For details [P.I-26](#)

As two shapes of slide unit, flange type and block type (with small width) and 3 types with different slide unit length with same section are available, you can select an optimal product for the specifications of your machine and device.

3 Stainless steel selections superior in corrosion resistance are listed on lineup. For details [P.I-39](#)

Products made of stainless steel are highly resistant to corrosion, so that they are suitable for applications where rust prevention oil is not preferred, such as in cleanroom environment.

4 Achieved smooth and quiet motion Low Decibel Linear Way E

Due to resin separator built-in balls, Low Decibel Linear Way E achieved smooth and quiet motion by eliminating of direct contact of balls each other. This feature reduces noise level in factory and contributes to a human-friendly environment.

Identification Number and Specification

Example of an identification number

The specifications of ME and LWE (---Q) series are indicated by the identification number. Indicate the identification number, consisting of a model code, dimensions, a part code, a material code, a preload symbol, a classification symbol, an interchangeable code, and any supplemental codes for each specification to apply.

Non-interchangeable specification	1	2	3	4	5	1	6	7	8	9	10
Assembled set	ME	C	20	C1	R1000			T ₁	P		/FU
Interchangeable specification											
Single slide unit	ME	C	20	C1				T ₁	P	S1	/U
Single track rail (1)	LWE		20		R1000				P	S1	/F
Assembled set	ME	C	20	C1	R1000			T ₁	P	S1	/FU

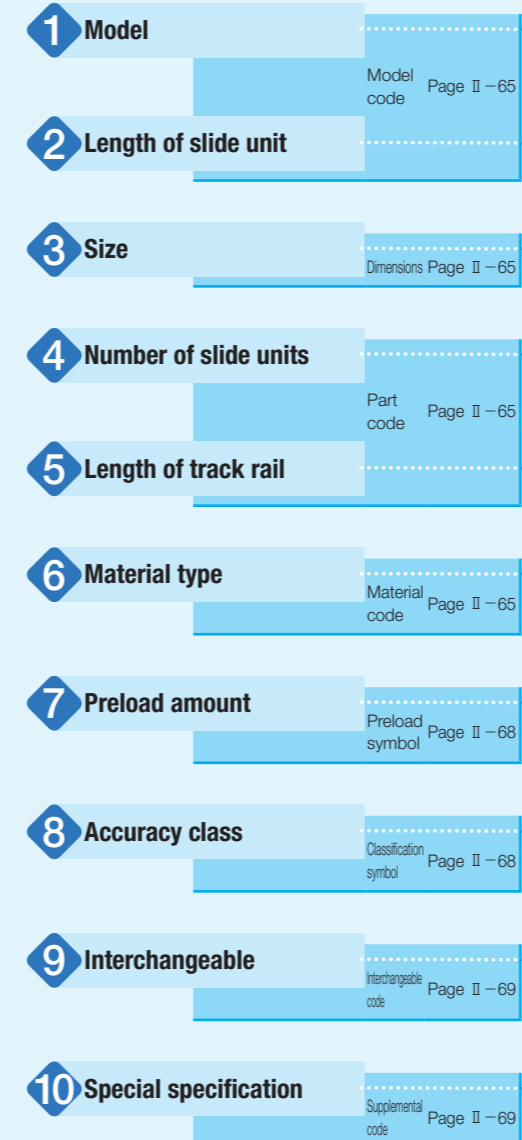

Note (1) Indicate "LWE" for the model code of the single track rail regardless of the series and the combination of slide unit model.

Identification Number and Specification —Model · Length of Slide Unit · Size ·

1 Model	C-Lube Linear Way ME (ME series)	Flange type mounting from bottom : ME Flange type mounting from top : MET Block type mounting from top : MES
	Linear Way E ⁽¹⁾ (LWE series)	Flange type mounting from bottom : LWE Flange type mounting from top : LWET Block type mounting from top : LWES
	Low Decibel Linear Way E ⁽¹⁾ (LWE...Q series)	Flange type mounting from bottom : LWE...Q Flange type mounting from top : LWET...Q Block type mounting from top : LWES...Q

For applicable models and sizes, see Table 1.
Indicate "LWE" for the model code of single track rail regardless of the series and the slide unit model to be combined.

Note ⁽¹⁾ This model has no built-in C-Lube.

2 Length of slide unit	Short	: C	For applicable models and sizes, see Table 1.
	Standard	: No symbol	
	Long	: G	

3 Size	15,20,25,30,35,45	For applicable models and sizes, see Table 1.
---------------	-------------------	---

4 Number of slide units	: C○	For an assembled set, indicates the number of slide units assembled on a track rail. For a single slide unit, only "C1" is specified.
--------------------------------	------	---

5 Length of track rail	: R○	Indicate the length of track rail in mm. For standard and maximum lengths, see Tables 2.1 and 2.2.
-------------------------------	------	---

6 Material type	High carbon steel made	: No symbol	For applicable models and sizes, see Table 1.
	Stainless steel made ⁽²⁾	: SL	

Note ⁽²⁾ Mount a standard grease nipple (brass) on the stainless steel type, too.
Stainless steel grease nipple is also available. If needed, please contact **IKO**.

ALMOTION

Number of Slide Unit · Length of Track Rail · Material—

Table 1 Models and sizes of ME and LWE (...Q) series

Material	Shape	Slide unit Length	Model	Size					
				15	20	25	30	35	45
High carbon steel made	Flange type mounting from bottom	Short	MEC	○	○	○	○	○	—
			LWEC	○	○	○	○	○	—
		Standard	ME	○	○	○	○	○	○
			LWE	○	○	○	○	○	○
			LWE...Q	○	○	○	○	○	—
		Long	MEG	○	○	○	○	—	—
		LWEG	○	○	○	○	—	—	
	Flange type mounting from top	Short	METC	○	○	○	○	○	—
			LWETC	○	○	○	○	○	—
		Standard	MET	○	○	○	○	○	○
			LWET	○	○	○	○	○	○
			LWET...Q	○	○	○	○	○	—
Long		METG	○	○	○	○	—	—	
	LWETG	○	○	○	○	—	—		
Block type mounting from top	Short	MESC	○	○	○	○	○	—	
		LWESC	○	○	○	○	○	—	
	Standard	MES	○	○	○	○	○	○	
		LWES	○	○	○	○	○	○	
		LWES...Q	○	○	○	○	○	—	
	Long	MESG	○	○	○	○	—	—	
	LWESG	○	○	○	○	—	—		
Stainless steel made	Flange type mounting from bottom	Short	MEC...SL	○	○	○	○	—	—
			LWEC...SL	○	○	○	○	—	—
		Standard	ME...SL	○	○	○	○	—	—
			LWE...SL	○	○	○	○	—	—
			LWE...SL	○	○	○	○	—	—
		Long	MEG...SL	○	○	○	○	—	—
		LWEG...SL	○	○	○	○	—	—	
	Flange type mounting from top	Short	METC...SL	○	○	○	○	—	—
			LWETC...SL	○	○	○	○	—	—
		Standard	MET...SL	○	○	○	○	—	—
			LWET...SL	○	○	○	○	—	—
			LWET...SL	○	○	○	○	—	—
Long		METG...SL	○	○	○	○	—	—	
	LWETG...SL	○	○	○	○	—	—		
Block type mounting from top	Short	MESC...SL	○	○	○	○	—	—	
		LWESC...SL	○	○	○	○	—	—	
	Standard	MES...SL	○	○	○	○	—	—	
		LWES...SL	○	○	○	○	—	—	
		LWES...SL	○	○	○	○	—	—	
	Long	MESG...SL	○	○	○	○	—	—	
	LWESG...SL	○	○	○	○	—	—		

Remark: For the models indicated in , the interchangeable specification is available.

ME · LWE

Table 2.1 Standard and maximum lengths of high carbon steel track rails

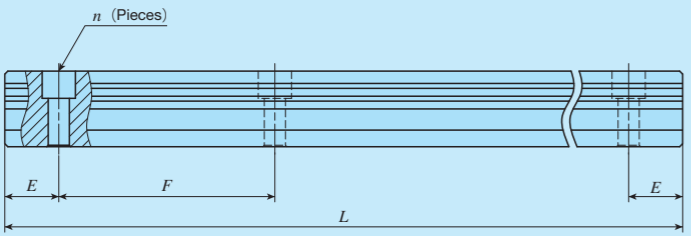

Item	Identification number	ME 15	ME 20	ME 25	ME 30	ME 35	ME 45
		LWE 15 LWE 15...Q	LWE 20 LWE 20...Q	LWE 25 LWE 25...Q	LWE 30 LWE 30...Q	LWE 35 LWE 35...Q	LWE 45
Standard length L (n)		160 (3)	220 (4)	220 (4)	280 (4)	280 (4)	570 (6)
		220 (4)	280 (5)	280 (5)	440 (6)	440 (6)	885 (9)
		280 (5)	340 (6)	340 (6)	600 (8)	600 (8)	1 200 (12)
		340 (6)	460 (8)	460 (8)	760 (10)	760 (10)	1 620 (16)
		460 (8)	640 (11)	640 (11)	1 000 (13)	1 000 (13)	2 040 (20)
		640 (11)	820 (14)	820 (14)	1 240 (16)	1 240 (16)	2 460 (24)
	820 (14)	1 000 (17)	1 000 (17)	1 640 (21)	1 640 (21)	2 985 (29)	
		1 240 (21)	1 240 (21)	2 040 (26)	2 040 (26)		
Pitch of mounting holes F		60	60	60	80	80	105
E (1)		20	20	20	20	20	22.5
Standard E dimensions (2)	or higher	6	8	9	9	10	12
	below	36	38	39	49	50	64.5
Maximum length (3)		1 600 (2 980)	2 200 (2 980)	2 980 (4 000)	3 000 (3 960)	3 000 (3 960)	2 985 (3 930)

Notes (1) When specifying a butt-jointing track rail (supplemental code "/T"), pay attention to the E dimension at the butt-jointing part.
 (2) Not applicable to the track rail with female threads for bellows (supplemental code "/J").
 (3) Length up to the value in () can be produced. If needed, please contact **IKO**. The values in () is not applicable to LWE...Q series.

Remarks 1. A typical identification number is indicated, but is applied to all models of the same size.
 2. Indicate "LWE" for the model code of single track rail regardless of the series and the slide unit model to be combined.
 3. If not directed, E dimensions for both ends will be the same within the range of standard E dimensions. To change the dimensions, indicate the specified rail mounting hole positions "/E" of special specification. For more information, see page III - 30.

Table 2.2 Standard and maximum lengths of stainless steel track rails unit: mm

Item	Identification number	ME 15...SL	ME 20...SL	ME 25...SL	ME 30...SL
		LWE 15...SL	LWE 20...SL	LWE 25...SL	LWE 30...SL
Standard length L (n)		160 (3)	220 (4)	220 (4)	280 (4)
		220 (4)	280 (5)	280 (5)	440 (6)
		280 (5)	340 (6)	340 (6)	600 (8)
		340 (6)	460 (8)	460 (8)	760 (10)
		460 (8)	640 (11)	640 (11)	1 000 (13)
		640 (11)	820 (14)	820 (14)	
	820 (14)	1 000 (17)	1 000 (17)		
Pitch of mounting holes F		60	60	60	80
E (1)		20	20	20	20
Standard E dimensions (2)	or higher	6	8	9	9
	below	36	38	39	49
Maximum length (3)		1 200 (1 600)	1 200 (1 960)	1 200 (1 960)	1 200 (1 960)

Notes (1) When specifying a butt-jointing track rail (supplemental code "/T"), pay attention to the E dimension at the butt-jointing part.
 (2) Not applicable to the track rail with female threads for bellows (supplemental code "/J").
 (3) Length up to the value in () can be produced. If needed, please contact **IKO**.

Remarks 1. A typical identification number is indicated, but is applied to all models of the same size.
 2. Indicate "LWE" for the model code of single track rail regardless of the series and the slide unit model to be combined.
 3. If not directed, E dimensions for both ends will be the same within the range of standard E dimensions. To change the dimensions, indicate the specified rail mounting hole positions "/E" of special specification. For more information, see page III - 30.

7 Preload amount	Clearance	: T _c	Specify this item for an assembled set or a single slide unit.
	Standard	: No symbol	For details of the preload amount, see Table 3.
	Light preload	: T ₁	For applicable combinations of accuracy class and preload amount, see Table 4.
	Medium preload	: T ₂	
8 Accuracy class	Ordinary	: No symbol	For interchangeable specification products, assemble a slide unit and a track rail of the same accuracy class.
	High	: H	For details of accuracy class, see Table 5.
	Precision	: P	
	Super precision	: SP	For applicable combinations of accuracy class and preload amount, see Table 4.

Table 3 Preload amount

Preload type	Preload symbol	Preload amount N	Operational conditions
Clearance	T _c	0 ⁽¹⁾	• Very light motion • To absorb slight errors
Standard	(No symbol)	0 ⁽²⁾	• Light and precise motion • Almost no vibrations
Light preload	T ₁	0.02C ₀	• Load is evenly balanced • Light and precise motion
Medium preload	T ₂	0.05C ₀	• Medium vibration • Medium overhung load

Notes (1) Clearance of about 10 μm
 (2) Indicates zero or minimal amount of preload
 Remark: C₀ indicates the basic static load rating.

Table 4 Combination of accuracy class and preload

Preload type (preload symbol)	Classification (classification symbol)			
	Ordinary (No symbol)	High (H)	Precision (P)	Super precision (SP)
Clearance (T _c) (1)	○	—	—	—
Standard (no symbol)	○	○	○	○
Light preload (T ₁)	—	○	○	○
Medium preload (T ₂) (1)	—	○	○	○

Note (1) Not applicable to LWE...Q series.
 Remark: The mark indicates that interchangeable specification products are available.

Table 5 Tolerance and allowance

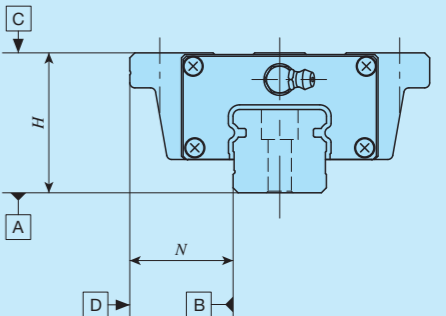

Item	Class (classification symbol)	Ordinary	High	Precision	Super precision
		(No symbol)	(H)	(P)	(SP)
Dim. H tolerance		±0.080	±0.040	±0.020	±0.010
Dim. N tolerance		±0.100	±0.050	±0.025	±0.015
Dim. variation of H (1)		0.025	0.015	0.007	0.005
Dim. variation of N (1)		0.030	0.020	0.010	0.007
Dim. variation of H for multiple assembled sets (2)		0.045	0.035	0.025	—
Parallelism in operation of the slide unit C surface to A surface		See Fig. 1.			
Parallelism in operation of the slide unit D surface to B surface		See Fig. 1.			

Notes (1) It means the size variation between slide units mounted on the same track rail.
 (2) Applicable to the interchangeable specification.

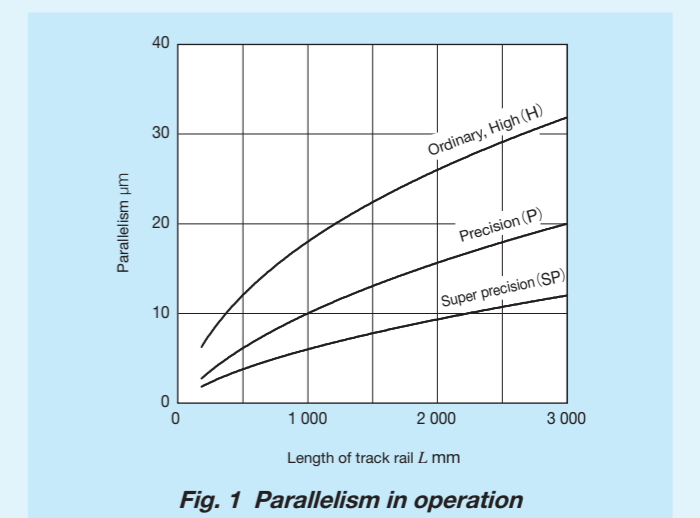
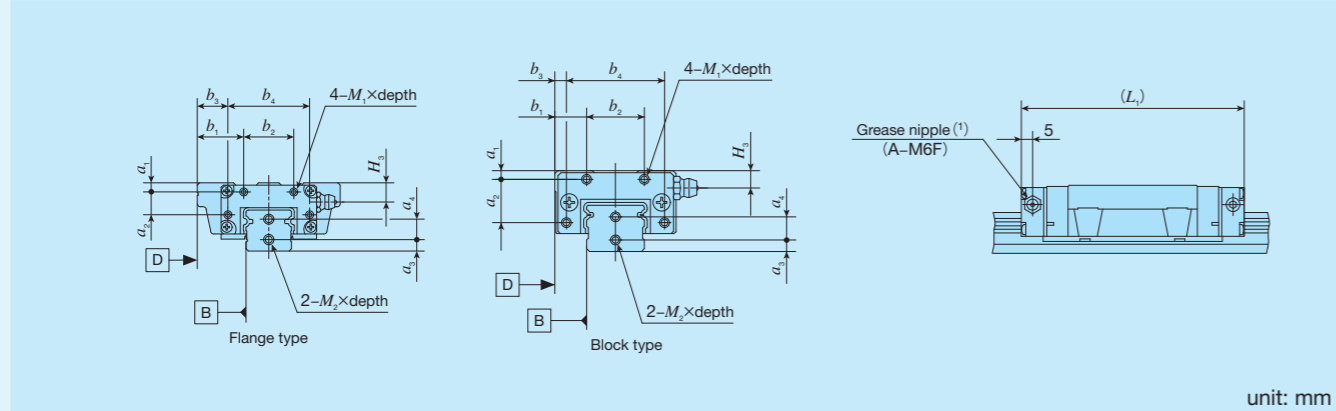

Table 8 Dimension of female threads for bellows (Supplemental code Single unit: /J Assembled set: /J /JJ)



Identification number			Slide unit							Track Rail				
			a_1	a_2	b_1	b_2	b_3	b_4	$M_1 \times \text{depth}$	$L_1^{(2)}$	H_3	a_3	a_4	$M_2 \times \text{depth}$
ME(T)C 15	LWE(T)C 15	—	3	12	18	12	28	M3×6	58	5.7	4	7	M3×6	
ME(T) 15	LWE(T) 15	LWE(T) 15...Q			74									
ME(T)G 15	LWE(T)G 15	—			87									
MESC 15	LWESC 15	—	3	15	9	3	34	M3×6	58	6	4	8	M3×6	
MES 15	LWES 15	LWES 15...Q			74									
MESG 15	LWESG 15	—			87									
ME(T)C 20	LWE(T)C 20	—	3.5	17	19.5	12.5	40	M3×6	64	7	5	9	M4×8	
ME(T) 20	LWE(T) 20	LWE(T) 20...Q			83									
ME(T)G 20	LWE(T)G 20	—			99									
MESC 20	LWESC 20	—	5	17	11	4	50	M3×6	64	11	6	14	M4×8	
MES 20	LWES 20	LWES 20...Q			83									
MESG 20	LWESG 20	—			99									
ME(T)C 25	LWE(T)C 25	—	5	17	23.5	16.5	50	M3×6	76	11	6	14	M4×8	
ME(T) 25	LWE(T) 25	LWE(T) 25...Q			100									
ME(T)G 25	LWE(T)G 25	—			119									
MESC 25	LWESC 25	—	6	20	11	4	60	M3×6	76	11	7	15	M4×8	
MES 25	LWES 25	LWES 25...Q			100									
MESG 25	LWESG 25	—			119									
ME(T)C 30	LWE(T)C 30	—	6	20	17	28	34	60	M3×6	83	11	7	15	M4×8
ME(T) 30	LWE(T) 30	—			112									
—	—	LWE(T) 30...Q			111									
ME(T)G 30	LWE(T)G 30	—	7	26	20	20	74	M4×8	144	11	8	19	M5×10	
MESC 30	LWESC 30	—			83									
MES 30	LWES 30	—			112									
—	—	LWES 30...Q	111											
MESG 30	LWESG 30	—	7	26	17	13	34	74	M4×8	126	13	8	19	M5×10
ME(T)C 35	LWE(T)C 35	—			144									
ME(T) 35	LWE(T) 35	—			83									
—	—	LWE(T) 35...Q	112											
MESC 35	LWESC 35	—	7	26	20	10	40	74	M4×8	125	11	8	19	M5×10
MES 35	LWES 35	—			111									
—	—	LWES 35...Q			144									
ME(T) 45	LWE(T) 45	—	7	26	30	20	74	M4×8	93	13	8	19	M5×10	
MES 45	LWES 45	—			126									
—	—	LWES 45...Q			125									

Notes (1) The specification and mounting positions of grease nipple are different from those of the standard specification product. Provided grease nipple for size 15 models is NPB2 type (special specification).
For details of dimensions, please contact **IKO**

(2) Dimensions of the specification that female threads for bellows are fitted to both ends of the slide unit are indicated.

Remark: This is also applicable to stainless steel models of the same size.

ALMOTION

Table 9 Track rail mounting bolt size (Supplemental code /MA)

Size	Bolt size for track rail
15	M 3×16 M 4×16 ⁽¹⁾
20	M 5×16
25	M 6×20
30	M 6×25
35	M 8×30
45	M10×35

Note (1) Applicable to the track rail of supplemental code "/M4" of special specification.

Remarks 1. Hexagon socket head bolts equivalent to JIS B 1176
2. For stainless steel model, stainless steel made bolts are appended.

Table 10 Changed dimensions of mounting holes (Supplemental code /M4)

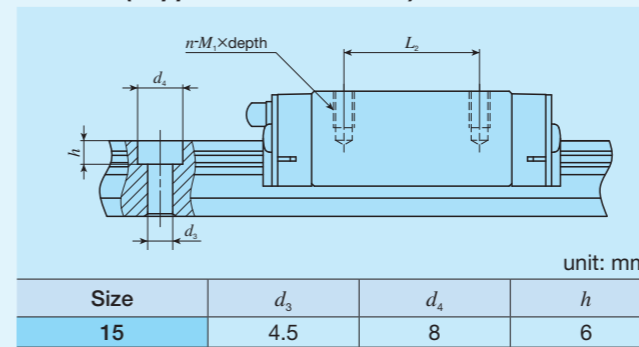

unit: mm

Size	d_3	d_4	h
15	4.5	8	6

Table 11 Dimension of slide unit with C-Lube plate (Supplemental code /Q)

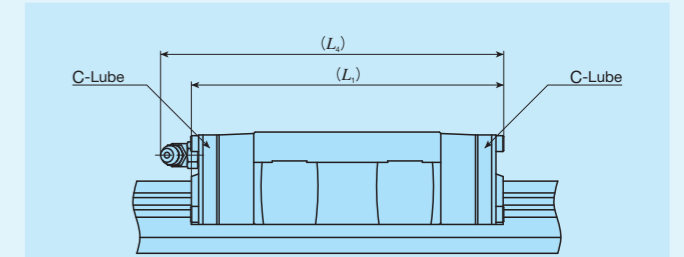

unit: mm

Identification number			L_1	L_2
LWEC 15	—	—	52	55
LWE 15	—	—	68	71
—	LWE15...Q	—		70
LWEG 15	—	—	81	83
LWEC 20	—	—	58	70
LWE 20	LWE20...Q	—	78	90
LWEG 20	—	—	94	105
LWEC 25	—	—	70	82
LWE 25	LWE25...Q	—	94	106
LWEG 25	—	—	113	125
LWEC 30	—	—	80	91
LWE 30	LWE30...Q	—	109	119
LWEG 30	—	—	141	151
LWEC 35	—	—	90	102
LWE 35	—	—	123	135
—	LWE35...Q	—	124	
LWE 45	—	—	138	148

Remarks 1. The dimensions of the slide unit with C-Lube at both ends are indicated.

2. A typical identification number is indicated, but is applied to all LWE (...Q) series models of the same size.

Table 12 H_1 dimension with under seal (Supplemental code /U)

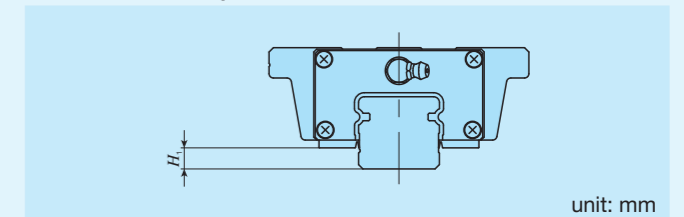

unit: mm

Identification number			H_1
ME 15	LWE 15	—	5
ME 20	LWE 20	—	5
ME 25	LWE 25	—	6
ME 30	—	—	9
—	LWE 30	—	7
ME 35	—	—	10
—	LWE 35	—	8
ME 45	—	—	13
—	LWE 45	—	10

Remark: A typical identification number is indicated, but is applied to all models of the same size.

Table 13 Dimension of slide unit with double end seals
(Supplemental code Single unit: /V
Assembled set: /V /VV)

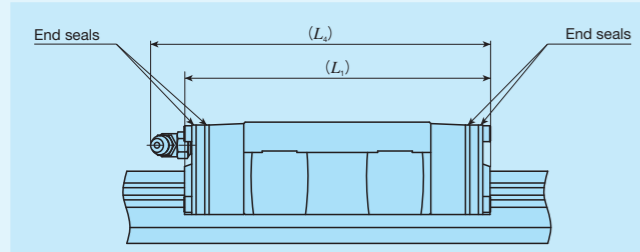

unit: mm

Identification number			L ₁	L ₄
MEC 15	LWEC 15	—	48	50
ME 15	LWE 15	LWE15...Q	64	66
MEG 15	LWEG 15	—	76	78
MEC 20	LWEC 20	—	54	68
ME 20	LWE 20	LWE20...Q	73	87
MEG 20	LWEG 20	—	89	103
MEC 25	LWEC 25	—	67	80
ME 25	LWE 25	LWE25...Q	91	104
MEG 25	LWEG 25	—	110	123
MEC 30	LWEC 30	—	78	89
ME 30	LWE 30	LWE30...Q	107	118
MEG 30	LWEG 30	—	138	150
MEC 35	LWEC 35	—	88	101
ME 35	LWE 35	LWE35...Q	121	134
ME 45	LWE 45	—	137	148

Remarks 1. The dimensions of the slide unit with double end seals at both ends are indicated.
2. A typical identification number is indicated, but is applied to all models of the same size.

Table 14 Dimension of slide unit with scrapers
(Supplemental code Single unit: /Z
Assembled set: /Z /ZZ)

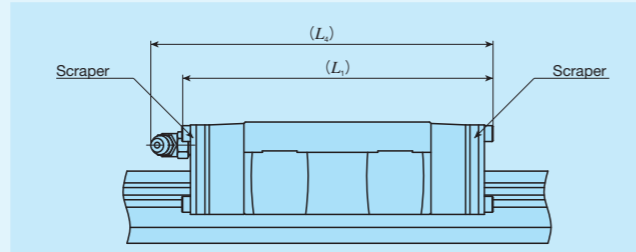

unit: mm

Identification number			L ₁	L ₄
MEC 15	LWEC 15	—	48	50
ME 15	LWE 15	LWE15...Q	64	66
MEG 15	LWEG 15	—	77	79
MEC 20	LWEC 20	—	55	69
ME 20	LWE 20	LWE20...Q	75	88
MEG 20	LWEG 20	—	91	104
MEC 25	LWEC 25	—	69	81
ME 25	LWE 25	LWE25...Q	93	105
MEG 25	LWEG 25	—	112	124
MEC 30	LWEC 30	—	79	90
ME 30	LWE 30	—	108	119
—	—	LWE30...Q	109	119
MEG 30	LWEG 30	—	140	151
MEC 35	LWEC 35	—	89	101
ME 35	LWE 35	—	122	134
—	—	LWE35...Q	123	135
ME 45	LWE 45	—	138	148

Remarks 1. The dimensions of the slide unit with scraper at both ends are indicated.
2. A typical identification number is indicated, but is applied to all models of the same size.

Lubrication

Lithium-soap base grease with extreme-pressure additive (Alvania EP grease 2 [SHOWA SHELL SEKIYU K. K.]) is pre-packed in ME and LWE (...Q) series. Additionally, ME series has C-Lube placed in the recirculation part of balls, so that the interval for reapplying lubricant can be extended and maintenance works such as grease job can be reduced significantly.
ME and LWE (...Q) series have grease nipple as indicated in Table 15. Supply nozzles fit to each shapes of grease nipple are also available. For order of these parts for lubrication, see Table 14.1 on page III-23 and Table 15 on page III-24.

Table 15 Parts for lubrication

Size	Grease nipple type ⁽¹⁾	Applicable supply nozzle type	Bolt size of female threads for piping
15	A-M4	A-5120V A-5240V B-5120V B-5240V	M4
20	B-M6	Grease gun available on the market	M6
25			
30	JIS type 4		PT1/8
35			
45			

Note ⁽¹⁾ For grease nipple specification, see Tables 14.1 and 14.2 on page III-23.
Remark: Stainless steel grease nipple is also available. If needed, please contact IKO.

Dust Protection

The slide units of ME and LWE (...Q) series are equipped with end seals as standard for dust protection. However, if large amount of contaminant or dust are floating, or if large particles of foreign substances such as chips or sand may adhere to the track rail, it is recommended to cover the whole unit with bellows or telescope type shield, etc.
ME series and LWE (...Q) series are provided with specific bellows. The bellows are easy to mount and provide excellent dust protection. If needed, please refer to III-26 for ordering.

Precaution for Use

① Mounting surface, reference mounting surface, and typical mounting structure

When mounting the ME and LWE (...Q) series, properly align the reference mounting surface B and D of the track rail and slide unit with the reference mounting surface of the table and bed and fix them. (See Fig. 2)

The reference mounting surfaces B and D and mounting surfaces A and C are precisely ground. Machining the mounting surface of the table and bed, such as machine or device, to high accuracy and mounting them properly will ensure stable linear motion with high accuracy. Reference mounting surface of the slide unit is the opposite side of the IKO mark. The track rail reference mounting surface is identified by locating the IKO mark on the top surface of the track rail. It is the side surface above the mark (in the direction of the arrow). (See Fig. 3.)

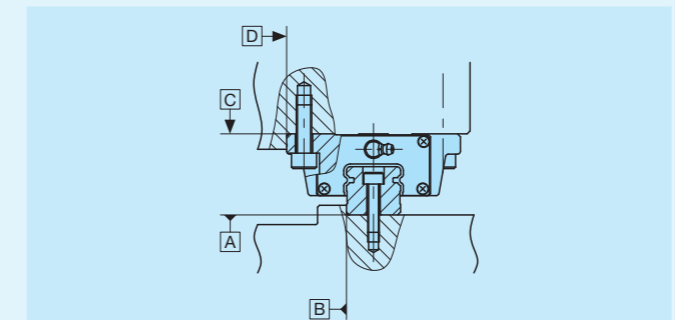

Fig. 2 Reference mounting surface and typical mounting structure

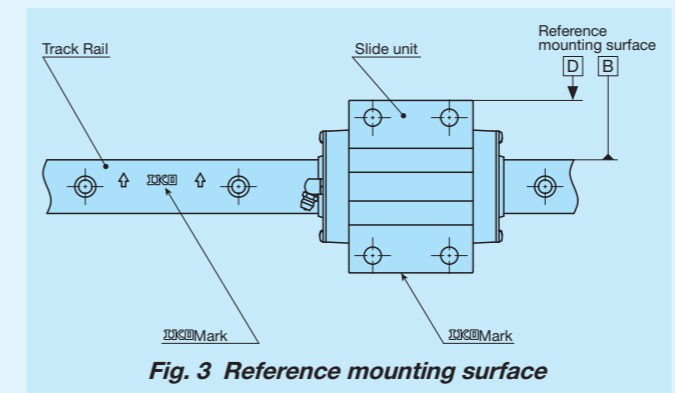

Fig. 3 Reference mounting surface

② Shoulder height and corner radius of the reference mounting surface

For the opposite corner of the mating reference mounting, it is recommended to have relieved fillet as indicated in Fig. 4. Recommended value for the shoulder height on the mating side is indicated in Table 17.

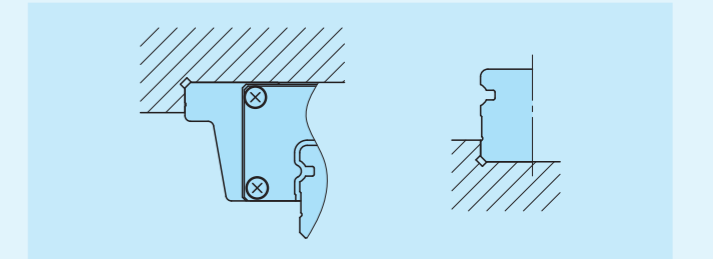

Fig. 4 Corner of the mating reference mounting

③ Tightening torque for fixing screw

Typical tightening torque for mounting of the ME and LWE (...Q) series to the steel mating member material is indicated in Table 16. When vibration and shock of the machine or device are large, fluctuating load is large, or moment load is applied, fix it by using the torque 1.2 to 1.5 times larger than the value indicated in the table as necessary. If the mating member material is cast iron or aluminum alloy, reduce the tightening torque depending on the strength characteristics of the mating member material.

Table 16 Tightening torque for fixing screw

Bolt size	Tightening torque N · m	
	High carbon steel-made screw	Stainless steel-made screw
M 3×0.5	1.8	1.1
M 4×0.7	4.1	2.5
M 5×0.8	8.0	5.0
M 6×1	13.6	8.5
M 8×1.25	32.7	20.4
M10×1.5	63.9	—
M12×1.75	110	—

Remark: The tightening torque is calculated based on strength division 12.9 and property division A2-70.

Table 17 Shoulder height and corner radius of the reference mounting surface

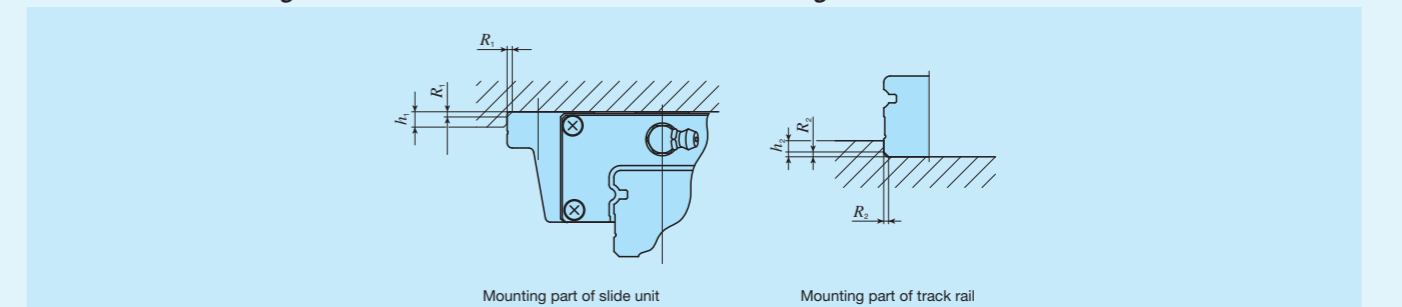

unit: mm

Size	Mounting part of slide unit		Mounting part of track rail	
	Shoulder height h ₁	Corner radius R ₁ (maximum)	Shoulder height h ₂	Corner radius R ₂ (maximum)
15	4	1 (0.5) ⁽¹⁾	3	0.5
20	5	1 (0.5) ⁽¹⁾	3	0.5
25	6	1	4	1
30	8	1	5	1
35	8	1	6	1
45	8	1.5	7	1.5

Note ⁽¹⁾ The values in () are applied to MES and LWES (...Q).

1N=0.102kgf=0.2248lbs.
1mm=0.03937inch

IKO C-Lube Linear Way ME

Flange type mounting from bottom

Shape	ME · LWE		
Size	15	20	25
	30	35	45

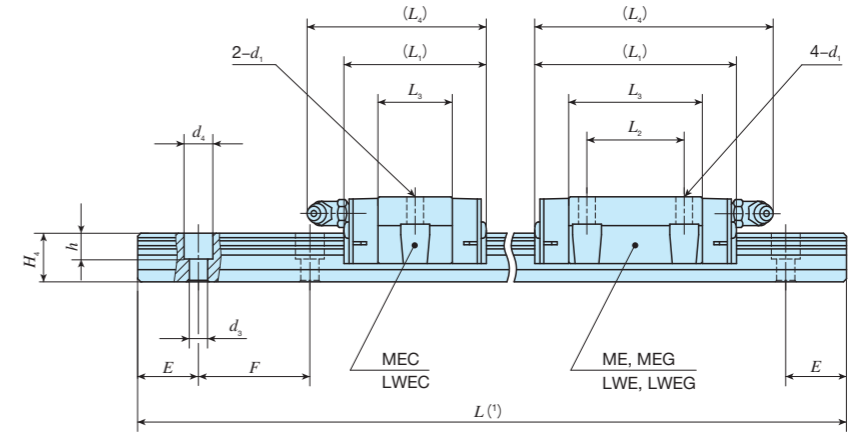
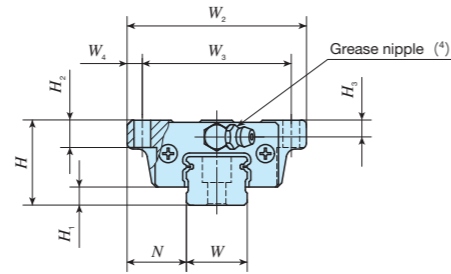

Identification number	Interchangeable	Mass (Ref.)		Dimensions of assembly mm					Dimensions of slide unit mm					Dimensions of track rail mm						Recommended mounting bolt for track rail (2) mm Bolt size × ℓ	Basic dynamic load rating (3) C N	Basic static load rating (3) C ₀ N	Static moment rating (3)												
		Slide unit kg	Track rail kg/m	H	H ₁	N	W ₂	W ₃	W ₄	L ₁	L ₂	L ₃	L ₄	d ₁	H ₂	H ₃	W	H ₄	d ₃				d ₄	h	E	F	T ₀ N · m	T _x N · m	T _y N · m						
MEC 15	LWEC 15	0.11	1.57	24	5.8	18.5	52	41	5.5	41	—	22.4	45	4.5	ALMOTION	7	4.5	15	14.5	3.6 (4.5)	6.5 (8)	4.5 (6)	20	60	M3×16 (M4×16)	5 240	5 480	43.8	21.3 149	21.3 149					
MEC 15...SL	LWEC 15...SL									57	26	38.4	61													6 550	8 610	68.9	53.0 307	53.0 307					
ME 15	LWE 15									70	36	51.1	73													9 340	12 500	100	99.5 533	99.5 533					
ME 15...SL	LWE 15...SL									70	36	51.1	73													9 340	12 500	100	99.5 533	99.5 533					
—	LWE 15...Q	—	—	5	—	—	—	—	—	—	—	—	—	—		—	—	—	—	—	—	—	—	—	—	—	—	—	—	—					
MEG 15	LWEG 15	0.24	—	—	5.8	—	—	—	—	70	36	51.1	73	—		—	—	—	—	—	—	—	—	—	—	9 340	12 500	100	99.5 533	99.5 533					
MEG 15...SL	LWEG 15...SL									9 340	12 500	100	99.5 533													99.5 533									
MEC 20	LWEC 20	0.18	—	—	—	—	—	—	—	47	—	24.7	58	—		ALMOTION	—	—	—	—	—	—	—	—	—	—	7 580	7 340	78.9	31.5 235	31.5 235				
MEC 20...SL	LWEC 20...SL									47	—	24.5	58														7 570					7 340	78.9	31.5 235	31.5 235
ME 20	LWE 20									67	32	44.2	78														11 600					13 400	145	95.6 566	95.6 566
ME 20...SL	LWE 20...SL									67	32	44.2	78														11 600					13 400	145	95.6 566	95.6 566
—	LWE 20...Q	—	—	5	—	—	—	—	—	—	—	—	—	—			—	—	—	—	—	—	—	—	—	—	—	—	—	—	—				
MEG 20	LWEG 20	0.40	2.28	28	6	19.5	59	49	5	67	32	44.2	78	5.5	ALMOTION		9	5.5	20	16	6	9.5	8.5	20	60	M5×16	10 500	13 400	145	100 562	100 562				
MEG 20...SL	LWEG 20...SL									83	45	60.1	94														14 400			18 300	197	172 930	172 930		
MEG 20	LWEG 20									83	45	59.9	94														14 400			18 300	197	172 930	172 930		
MEG 20...SL	LWEG 20...SL	83	45	60.1	94	14 400	18 300	197	172 930	172 930																									

Notes (1) Track rail lengths L are shown in Tables 2.1 and 2.2 on page II - 67.
 (2) Track rail mounting bolts are not appended. Hexagon socket head bolts of JIS B 1176 with strength division 12.9 are recommended.
 (3) The direction of basic dynamic load rating (C), basic static load rating (C_0), and static moment rating (T_0 , T_x , T_y) are shown in the sketches below. The upper values of T_x and T_y are for one slide unit and the lower values are for two slide units in close contact.
 (4) The shapes of grease nipple vary by size. The specifications are shown in Table 15 on page II - 73.
 Remark: Values in () represent dimensions when the track rail mounting hole is "M4". Indicate the identification number with "/M4" at the end.

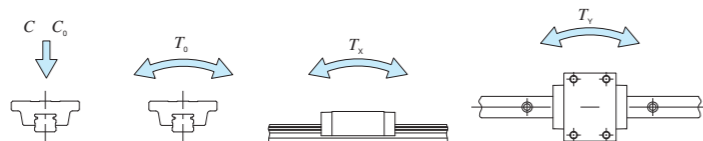

Example of identification number of assembled set

Model code	Dimensions	Part code	Model code	Material code	Preload symbol	Classification symbol	Interchangeable code	Supplemental code
ME	G	15	C2	R340	T1	P	—	/U
1	2	3	4	5	7	8	9	10

① Model ME LWE LWE...Q	② Length of slide unit C Short No symbol Standard G Long	③ Size 15, 20	④ Number of slide unit (2)	⑤ Length of track rail (340 mm)	⑥ Material type No symbol High carbon steel made SL Stainless steel made	⑦ Preload amount T ₀ Clearance No symbol Standard T ₁ Light preload T ₂ Medium preload	⑧ Accuracy class No symbol Ordinary H High P Precision SP Super precision	⑨ Interchangeable No symbol Non-interchangeable specification S1 S1 specification S2 S2 specification	⑩ Special specification A, BS, D, E, F, I, J, L, LF, MA M4, N, Q, RE, T, U, V, W, Y, Z
---------------------------------	---	------------------	----------------------------	---------------------------------	--	---	---	--	--

IKO C-Lube Linear Way ME

Flange type mounting from bottom

Shape	ME · LWE		
Size	15	20	25
	30	35	45

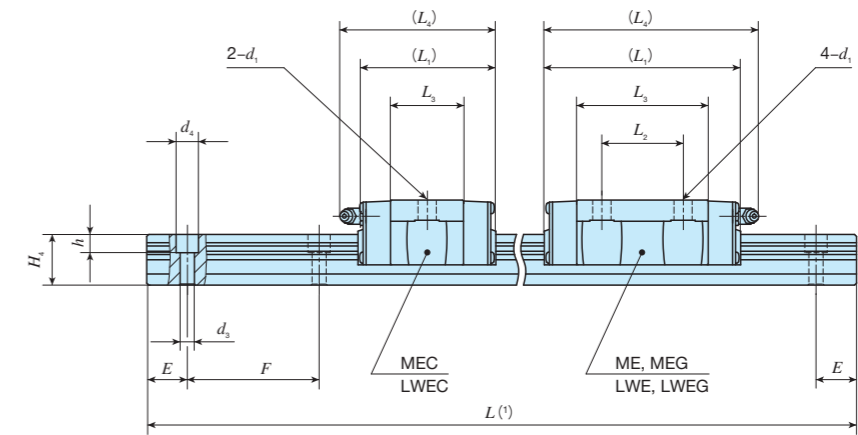
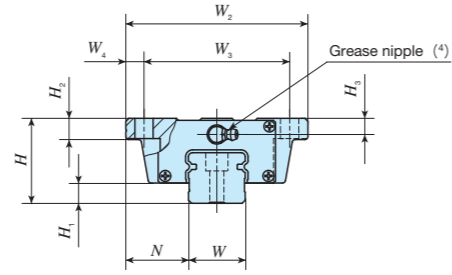

Identification number	Interchangeable	Mass (Ref.)		Dimensions of assembly mm					Dimensions of slide unit mm					Dimensions of track rail mm						Recommended mounting bolt for track rail mm Bolt size × ℓ	Basic dynamic load rating ⁽³⁾ C N	Basic static load rating ⁽³⁾ C ₀ N	Static moment rating ⁽³⁾							
		Slide unit kg	Track rail kg/m	H	H ₁	N	W ₂	W ₃	W ₄	L ₁	L ₂	L ₃	L ₄	d ₁	H ₂	H ₃	W	H ₄	d ₃				d ₄	h	E	F	T ₀ N · m	T _x N · m	T _y N · m	
MEC 25	LWEC 25	○	0.33	3.09	33	7	25	73	60	6.5	83	35	56	94	7	10	6.5	23	19	7	11	9	20	60	M 6×20	12 400	12 300	153	71.8 480	71.8 480
MEC 25...SL	LWEC 25...SL	○																												
ME 25	LWE 25	○																												
ME 25...SL	LWE 25...SL	○																												
—	LWE 25...Q	—																												
MEG 25	LWEG 25	○	0.56	3.09	33	6	25	73	60	6.5	83	35	56	94	7	10	6.5	23	19	7	11	9	20	60	M 6×20	18 100	21 100	262	195 1 090	195 1 090
MEG 25...SL	LWEG 25...SL	○																												
MEC 30	LWEC 30	○																												
MEC 30...SL	LWEC 30...SL	○																												
ME 30	LWE 30	○																												
ME 30...SL	LWE 30...SL	○	0.58	5.09	42	10	31	90	72	9	97	40	64.8	107	9	10	8	28	25	7	11	9	20	80	M 6×25	29 500	31 300	479	328 1 920	328 1 920
MEC 30...SL	LWEC 30...SL	○																												
ME 30	LWE 30	○																												
ME 30...SL	LWE 30...SL	○																												
—	LWE 30...Q	—																												
MEG 30	LWEG 30	○	0.73	5.09	42	10	31	90	72	9	97	40	64.8	107	9	10	8	28	25	7	11	9	20	80	M 6×25	21 600	26 400	398	278 1 580	278 1 580
MEG 30...SL	LWEG 30...SL	○																												
MEC 30	LWEC 30	○																												
MEC 30...SL	LWEC 30...SL	○																												
ME 30	LWE 30	○																												
ME 30...SL	LWE 30...SL	○	0.84	6.85	48	11	33	100	82	9	78	—	41.6	90	9	13	10	34	28	9	14	12	20	80	M 8×30	29 900	26 800	412	176 1 190	162 1 100
MEC 30	LWEC 30	○																												
MEC 30...SL	LWEC 30...SL	○																												
ME 30	LWE 30	○																												
ME 30...SL	LWE 30...SL	○																												
—	LWE 30...Q	—																												
MEG 30	LWEG 30	○	1.50	5.09	48	11	33	100	82	9	111	50	74.6	123	9	13	10	34	28	9	14	12	20	80	M 8×30	42 900	44 700	686	448 2 660	412 2 450
MEG 30...SL	LWEG 30...SL	○																												
MEC 35	LWEC 35	○																												
MEC 35	LWEC 35	○																												
ME 35	LWE 35	○																												
ME 35	LWE 35	○	1.52	6.84	60	14	37.5	120	100	10	125	60	81.4	136	11	15	13	45	34	11	17.5	14	22.5	105	M10×35	61 100	60 200	1 210	672 4 070	618 3 750
MEC 35	LWEC 35	○																												
ME 35	LWE 35	○																												
ME 35	LWE 35	○																												
—	LWE 35...Q	—																												
ME 45	LWE 45	○	2.46	11.2	60	14	37.5	120	100	10	125	60	81.4	136	11	15	13	45	34	11	17.5	14	22.5	105	M10×35	61 100	60 200	1 210	672 4 070	618 3 750
ME 45	LWE 45	○																												

Notes (1) Track rail lengths L are shown in Tables 2.1 and 2.2 on page II - 67.

(2) Track rail mounting bolts are not appended. Hexagon socket head bolts of JIS B 1176 with strength division 12.9 are recommended.

(3) The direction of basic dynamic load rating (C), basic static load rating (C₀), and static moment rating (T₀, T_x, T_y) are shown in the sketches below. The upper values of T_x and T_y are for one slide unit and the lower values are for two slide units in close contact.

(4) The shapes of grease nipple vary by size. The specifications are shown in Table 15 on page II - 73.

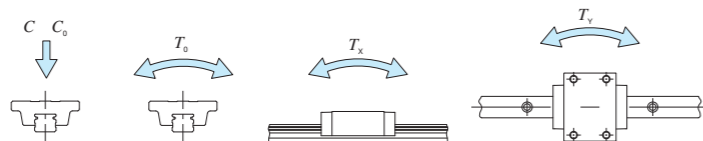

Example of identification number of assembled set

Model code	Dimensions	Part code	Model code	Material code	Preload symbol	Classification symbol	Interchangeable code	Supplemental code
ME	G	30	C2	R440	T1	P	—	/U
1	2	3	4	5	7	8	9	10

① Model	③ Size	⑦ Preload amount	⑨ Interchangeable
ME LWE LWE...Q Flange type mounting from bottom	25, 30, 35, 45	T ₀ Clearance No symbol Standard T ₁ Light preload T ₂ Medium preload	No symbol Non-interchangeable specification S1 S1 specification S2 S2 specification
② Length of slide unit	④ Number of slide unit (2)	⑧ Accuracy class	⑩ Special specification
C Short No symbol Standard G Long		No symbol Ordinary H High P Precision SP Super precision	A, BS, D, E, F, I, J, L, LF, MA N, Q, RE, T, U, V, W, Y, Z
⑤ Length of track rail (440 mm)	⑥ Material type		
	No symbol High carbon steel made SL Stainless steel made		

IKO C-Lube Linear Way ME

Flange type mounting from top

Shape	MET · LWET		
Size	15	20	25
	30	35	45

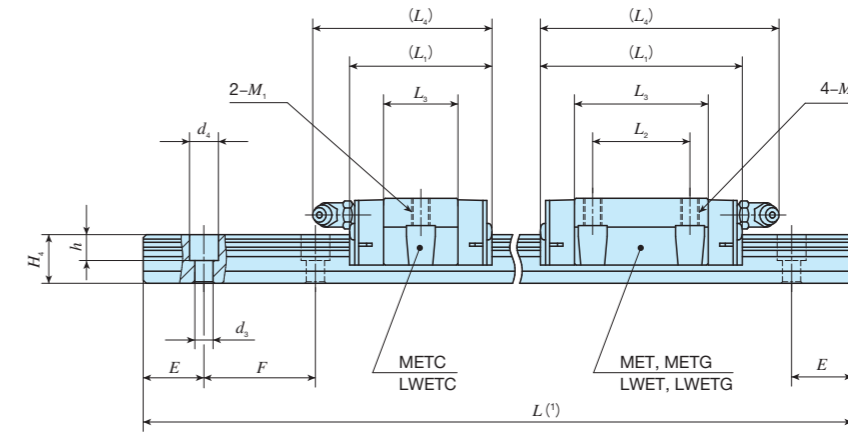
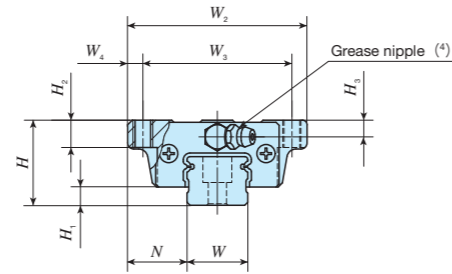

Identification number	Interchangeable	Mass (Ref.)		Dimensions of assembly mm			Dimensions of slide unit mm					Dimensions of track rail mm						Recommended mounting bolt for track rail (2) mm	Basic dynamic load rating (3) C N	Basic static load rating (3) C0 N	Static moment rating (3) N·m										
		Slide unit kg	Track rail kg/m	H	H1	N	W2	W3	W4	L1	L2	L3	L4	M1	H2	H3	W				H4	d3	d4	h	E	F	T0	Tx	Ty		
METC 15	LWETC 15	0.11	1.57	24	5.8	18.5	52	41	5.5	41	—	22.4	45	M5	7	4.5	15	14.5	3.6 (4.5)	6.5 (8)	4.5 (6)	20	60	M3×16 (M4×16)	5 240	5 480	43.8	21.3 149	21.3 149		
METC 15...SL	LWETC 15...SL									57	26	38.4	61												38.3	61	7 640	9 390	75.1	57.6 333	57.6 333
MET 15	LWET 15									5	38.3	61	38.3												61	6 550	8 610	68.9	53.0 307	53.0 307	
MET 15...SL	LWET 15...SL									5	38.3	61	38.3												61	6 550	8 610	68.9	53.0 307	53.0 307	
METG 15	LWETG 15	0.24			5.8					70	36	51.1	73												9 340	12 500	100	99.5 533	99.5 533		
METG 15...SL	LWETG 15...SL									70	36	51.1	73												9 340	12 500	100	99.5 533	99.5 533		
METC 20	LWETC 20	0.18								47	—	24.7	58												7 580	7 340	78.9	31.5 235	31.5 235		
METC 20...SL	LWETC 20...SL									47	—	24.5	58												7 570						
MET 20	LWET 20									44	—	24.7	58												7 580						
MET 20...SL	LWET 20...SL									44	—	24.5	58												7 570						
METG 20	LWETG 20	0.30	2.28	28	6	19.5	59	49	5	67	32	44.2	78	M6	9	5.5	20	16	6	9.5	8.5	20	60	M5×16	11 600	13 400	145	95.6 566	95.6 566		
METG 20...SL	LWETG 20...SL									67	32	44.2	78												11 600						
MET 20	LWET 20									44	—	44	78												10 500						
MET 20...SL	LWET 20...SL									44	—	44	78												10 500						
METG 20	LWETG 20	0.40			6					83	45	60.1	94												14 400	18 300	197	172 930	172 930		
METG 20...SL	LWETG 20...SL									83	45	59.9	94												14 400						
METG 20	LWETG 20									59.9	94	60.1	94												14 400						

Notes (1) Track rail lengths L are shown in Tables 2.1 and 2.2 on page II-67.
 (2) Track rail mounting bolts are not appended. Hexagon socket head bolts of JIS B 1176 with strength division 12.9 are recommended.
 (3) The direction of basic dynamic load rating (C), basic static load rating (C_0), and static moment rating (T_0 , T_x , T_y) are shown in the sketches below. The upper values of T_x and T_y are for one slide unit and the lower values are for two slide units in close contact.
 (4) The shapes of grease nipple vary by size. The specifications are shown in Table 15 on page II-73.
 Remark: Values in () represent dimensions when the track rail mounting hole is "M4". Indicate the identification number with "/M4" at the end.

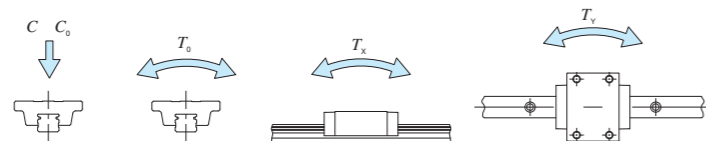

Example of identification number of assembled set

Model code	Dimensions	Part code	Model code	Material code	Preload symbol	Classification symbol	Interchangeable code	Supplemental code
MET	G	15	C2	R340	T1	P	/U	
1	2	3	4	5	6	7	8	9

1 Model MET LWET LWET...Q Flange type mounting from top	3 Size 15, 20	7 Preload amount T0 Clearance No symbol Standard T1 Light preload T2 Medium preload	9 Interchangeable No symbol Non-interchangeable specification S1 S1 specification S2 S2 specification
2 Length of slide unit C Short No symbol Standard G Long	4 Number of slide unit (2)	8 Accuracy class No symbol Ordinary H High P Precision SP Super precision	10 Special specification A, BS, D, E, F, I, J, L, LF, MA M4, N, Q, RE, T, U, V, W, Y, Z
5 Length of track rail (340 mm)	6 Material type No symbol High carbon steel made SL Stainless steel made		

IKO C-Lube Linear Way ME

Flange type mounting from top

Shape	MET · LWET		
Size	15	20	25
	30	35	45

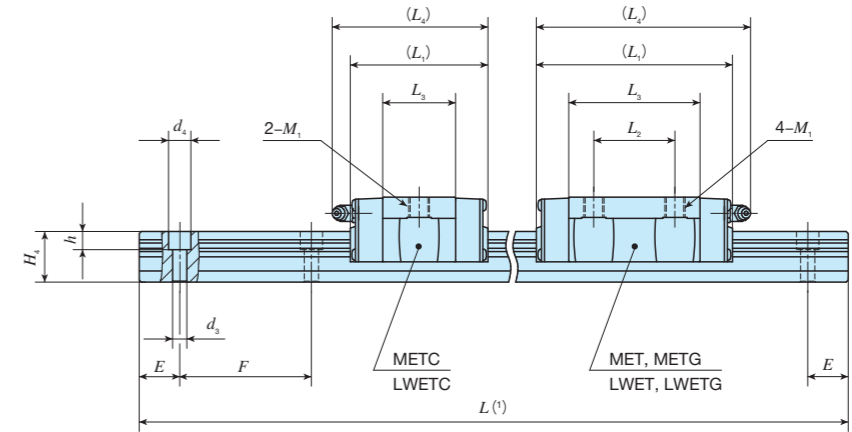
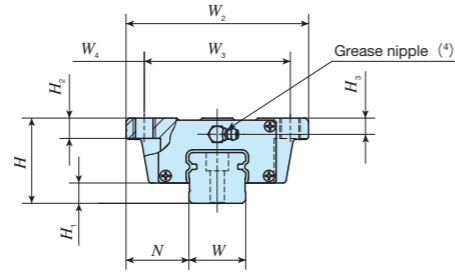

Identification number	ME series	LWE series (No C-Lube)	Interchangeable	Mass (Ref.)		Dimensions of assembly mm			Dimensions of slide unit mm						Dimensions of track rail mm						Recommended mounting bolt for track rail mm	Bolt size × ℓ	Basic dynamic load rating ⁽³⁾ C N	Basic static load rating ⁽³⁾ C ₀ N	Static moment rating ⁽³⁾																																																			
				Slide unit kg	Track rail kg/m	H	H ₁	N	W ₂	W ₃	W ₄	L ₁	L ₂	L ₃	L ₄	M ₁	H ₂	H ₃	W	H ₄					d ₃	d ₄	h	E	F	T ₀ N · m	T _x N · m	T _y N · m																																												
METC 25	LWETC 25		○	0.33	3.09	33	7	25	73	60	6.5	83	35	56	94	M 8	10	6.5	23	19	7	11	9	20	60	M 6×20	12 400	12 300	153	71.8 480	71.8 480																																													
METC 25...SL	LWETC 25...SL	○	0.56																								5.09	42	10	31	90	72	9	97	40	64.8	107	M10	10	8	28	25	7	11	9	20	80	M 6×25	18 100	21 100	262	195 1 090	195 1 090																							
MET 25	LWET 25	○																																															0.73	5.04	48	11	33	100	82	9	111	50	74.6	123	M10	13	10	34	28	9	14	12	20	80	M 8×30	15 500	19 400	240	175 1 010	175 1 010
MET 25...SL	LWET 25...SL	○																																																																						22 200	28 200	349	336 1 740	336 1 740
METG 25	LWETG 25	○	0.58	5.09	42	10	31	90	72	9	96	40	64.8	106	M10	10	8	28	25	7	11	9	20	80	M 6×25	20 600	18 800	287	129 855	129 855																																														
METG 25...SL	LWETG 25...SL	○																								0.99	6.85	60	14	37.5	120	100	10	125	60	81.4	136	M12	15	13	45	34	11	17.5	14	22.5	105	M10×35	29 500	31 300	479	328 1 920	328 1 920																							
METC 30	LWETC 30	○																																															1.50	6.84	48	11	33	100	82	9	110	50	76.6	122	M10	13	10	34	28	9	14	12	20	80	M 8×30	21 600	26 400	398	278 1 580	278 1 580
METG 30	LWETG 30	○																																																																						39 200	47 000	718	704 3 690	704 3 690
METC 30...SL	LWETC 30...SL	○	0.84	11.2	60	14	37.5	120	100	10	125	60	81.4	136	M12	15	13	45	34	11	17.5	14	22.5	105	M10×35	29 900	26 800	412	176 1 190	162 1 100																																														
MET 30	LWET 30	○																								1.52	6.84	60	14	37.5	120	100	10	125	60	81.4	136	M12	15	13	45	34	11	17.5	14	22.5	105	M10×35	42 900	44 700	686	448 2 660	412 2 450																							
MET 30...SL	LWET 30...SL	○																																															1.53	6.84	60	14	37.5	120	100	10	125	60	81.4	136	M12	15	13	45	34	11	17.5	14	22.5	105	M10×35	30 500	37 600	687	482 2 550	482 2 550
METG 30...SL	LWETG 30...SL	○																																																																						61 100	60 200	1 210	672 4 070	618 3 750

- Notes (1) Track rail lengths L are shown in Tables 2.1 and 2.2 on page II - 67.
 (2) Track rail mounting bolts are not appended. Hexagon socket head bolts of JIS B 1176 with strength division 12.9 are recommended.
 (3) The direction of basic dynamic load rating (C), basic static load rating (C_0), and static moment rating (T_0 , T_x , T_y) are shown in the sketches below. The upper values of T_x and T_y are for one slide unit and the lower values are for two slide units in close contact.
 (4) The shapes of grease nipple vary by size. The specifications are shown in Table 15 on page II - 73.

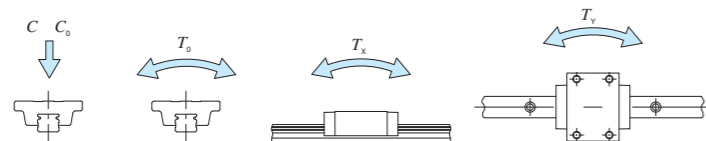

Example of identification number of assembled set

Model code	Dimensions	Part code	Model code	Material code	Preload symbol	Classification symbol	Interchangeable code	Supplemental code
MET	G	30	C2	R440	T1	P	/U	
1	2	3	4	5	6	7	8	9

1 Model MET LWET LWET...Q Flange type mounting from top	3 Size 25, 30, 35, 45	7 Preload amount T ₀ Clearance No symbol Standard T ₁ Light preload T ₂ Medium preload	9 Interchangeable No symbol Non-interchangeable specification S1 S1 specification S2 S2 specification
2 Length of slide unit C Short No symbol Standard G Long	4 Number of slide unit (2)	8 Accuracy class No symbol Ordinary H High P Precision SP Super precision	10 Special specification A, BS, D, E, F, I, J, L, LF, MA N, Q, RE, T, U, V, W, Y, Z

IKO C-Lube Linear Way ME

Block type mounting from top

Shape	MES · LWES		
Size	15	20	25
	30	35	45

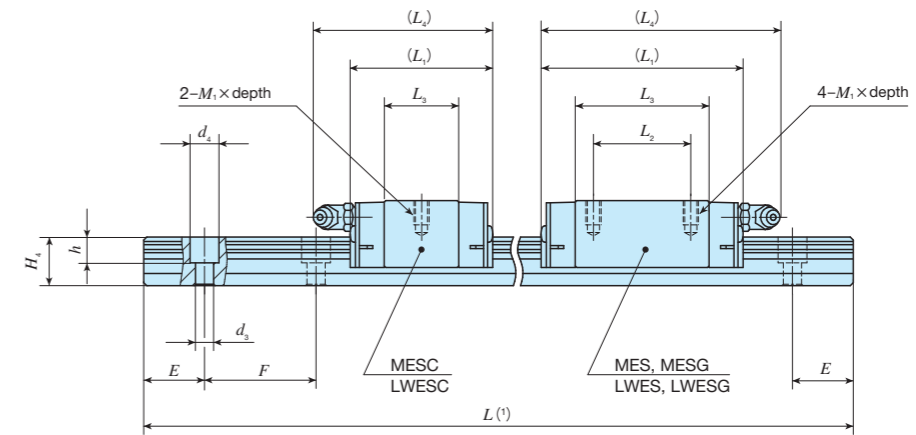
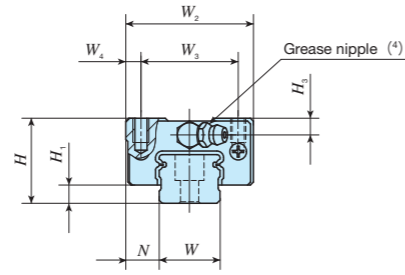

Identification number	Interchangeable	Mass (Ref.)		Dimensions of assembly mm					Dimensions of slide unit mm					Dimensions of track rail mm					Recommended mounting bolt for track rail (2) mm	Basic dynamic load rating (3) C N	Basic static load rating (3) C0 N	Static moment rating (3)						
		Slide unit kg	Track rail kg/m	H	H1	N	W2	W3	W4	L1	L2	L3	L4	M1 x depth	H3	W	H4	d3				d4	h	E	F	T0 N·m	Tx N·m	Ty N·m
MESC 15	LWESC 15	0.09	1.57	24	5.8	9.5	34	26	4	41	-	22.4	45	M4 x 7	4.5	15	14.5	3.6 (4.5)	6.5 (8)	4.5 (6)	20	60	M3 x 16 (M4 x 16)	5 240	5 480	43.8	21.3 149	21.3 149
MESC 15...SL	LWESC 15...SL									57	26	38.4	61											5	38.3	7 640	9 390	75.1
MES 15	LWES 15	0.14	1.57	24	5	9.5	34	26	4	70	36	51.1	73	M4 x 7	4.5	15	14.5	3.6 (4.5)	6.5 (8)	4.5 (6)	20	60	M3 x 16 (M4 x 16)	6 550	8 610	68.9	53.0 307	53.0 307
MES 15...SL	LWES 15...SL									57	26	38.4	61											5	38.3	7 640	9 390	75.1
MESG 15	LWESG 15	0.18	1.57	24	5.8	9.5	34	26	4	70	36	51.1	73	M4 x 7	4.5	15	14.5	3.6 (4.5)	6.5 (8)	4.5 (6)	20	60	M3 x 16 (M4 x 16)	9 340	12 500	100	99.5 533	99.5 533
MESG 15...SL	LWESG 15...SL									70	36	51.1	73											5	38.3	9 340	12 500	100
MESC 20	LWESC 20	0.15	2.28	28	6	11	42	32	5	47	-	24.7	58	M5 x 8	5.5	20	16	6	9.5	8.5	20	60	M5 x 16	7 580	7 340	78.9	31.5 235	31.5 235
MESC 20...SL	LWESC 20...SL									47	-	24.7	58											44	44	7 580	7 340	78.9
MES 20	LWES 20	0.25	2.28	28	5	11	42	32	5	67	32	44.2	78	M5 x 8	5.5	20	16	6	9.5	8.5	20	60	M5 x 16	11 600	13 400	145	95.6 566	95.6 566
MES 20...SL	LWES 20...SL									67	32	44.2	78											44	44	11 600	13 400	145
MESG 20	LWESG 20	0.33	2.28	28	6	11	42	32	5	83	45	60.1	94	M5 x 8	5.5	20	16	6	9.5	8.5	20	60	M5 x 16	14 400	18 300	197	172 930	172 930
MESG 20...SL	LWESG 20...SL									83	45	60.1	94											59.9	59.9	14 400	18 300	197

Notes (1) Track rail lengths L are shown in Tables 2.1 and 2.2 on page II - 67.
 (2) Track rail mounting bolts are not appended. Hexagon socket head bolts of JIS B 1176 with strength division 12.9 are recommended.
 (3) The direction of basic dynamic load rating (C), basic static load rating (C_0), and static moment rating (T_0 , T_x , T_y) are shown in the sketches below. The upper values of T_x and T_y are for one slide unit and the lower values are for two slide units in close contact.
 (4) The shapes of grease nipple vary by size. The specifications are shown in Table 15 on page II - 73.
 Remark: Values in () represent dimensions when the track rail mounting hole is "M4". Indicate the identification number with "/M4" at the end.

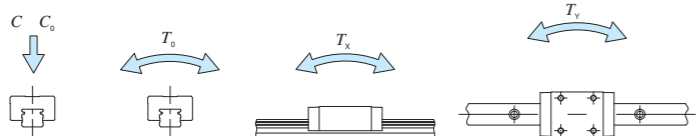

Example of identification number of assembled set

Model code	Dimensions	Part code	Model code	Material code	Preload symbol	Classification symbol	Interchangeable code	Supplemental code
MES	G	15	C2	R340	T1	P	/U	
1	2	3	4	5	6	7	8	9 10

① Model MES LWES LWES...Q	② Length of slide unit C Short No symbol Standard G Long	③ Size 15, 20	④ Number of slide unit (2)	⑤ Length of track rail (340 mm)	⑥ Material type No symbol High carbon steel made SL Stainless steel made	⑦ Preload amount T0 Clearance No symbol Standard T1 Light preload T2 Medium preload	⑧ Accuracy class No symbol Ordinary H High P Precision SP Super precision	⑨ Interchangeable No symbol Non-interchangeable specification S1 S1 specification S2 S2 specification	⑩ Special specification A, BS, D, E, F, I, J, L, LF, MA M4, N, Q, RE, T, U, V, W, Y, Z
------------------------------------	---	------------------	----------------------------	---------------------------------	--	---	---	--	--

IKO C-Lube Linear Way ME

Block type mounting from top

Shape	MES · LWES		
Size	15	20	25
	30	35	45

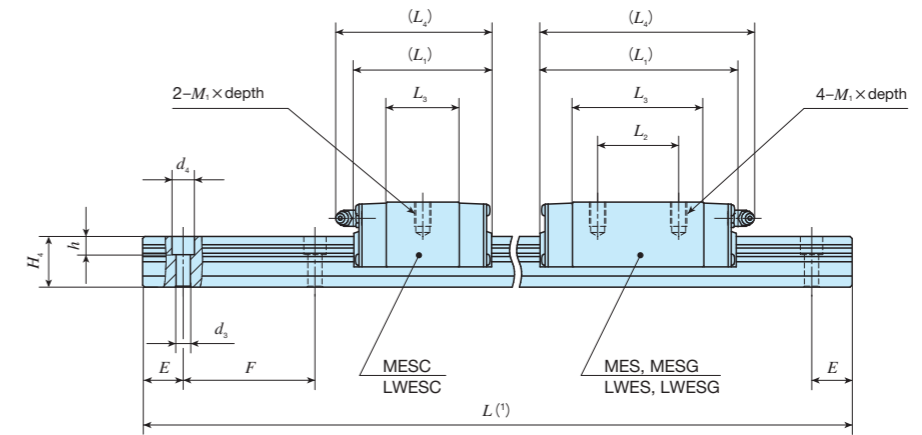
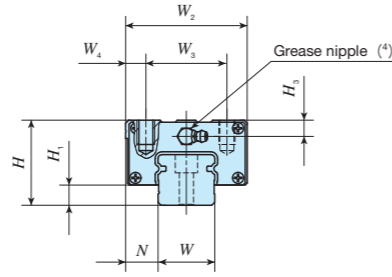

Identification number	ME series	LWE series (No C-Lube)	Interchangeable	Mass (Ref.)		Dimensions of assembly mm			Dimensions of slide unit mm					Dimensions of track rail mm						Recommended mounting bolt for track rail (2) mm	Bolt size × ℓ	Basic dynamic load rating (3) C N	Basic static load rating (3) C ₀ N	Static moment rating (3)						
				Slide unit kg	Track rail kg/m	H	H ₁	N	W ₂	W ₃	W ₄	L ₁	L ₂	L ₃	L ₄	M ₁ × depth	H ₃	W	H ₄					d ₃	d ₄	h	E	F	T ₀ N · m	T _x N · m
MESC 25	LWESC 25		○	0.26	3.09	33	7	12.5	48	35	6.5	59	—	32	70	M 6×9	6.5	23	19	7	11	9	20	60	M 6×20	12 400	12 300	153	71.8 480	71.8 480
MESC 25...SL	LWESC 25...SL	○	6									83	35	56	94											15 500	19 400	240	175 1 010	175 1 010
MES 25	LWES 25	○	7									102	50	75	113											22 200	28 200	349	336 1 740	336 1 740
MES 25...SL	LWES 25...SL	○	7									102	50	75	113											22 200	28 200	349	336 1 740	336 1 740
MESG 25	LWESG 25		○	0.46	5.09	42	10	16	60	40	10	68	—	36	78	M 8×12	8	28	25	7	11	9	20	80	M 6×25	20 600	18 800	287	129 855	129 855
MESC 30	LWESC 30	○	6									97	40	64.8	107											29 500	31 300	479	328 1 920	328 1 920
MESC 30...SL	LWESC 30...SL	○	7									96	40	64.8	106											21 600	26 400	398	278 1 580	278 1 580
MES 30	LWES 30	○	7									129	60	96.5	139											39 200	47 000	718	704 3 690	704 3 690
MESG 30	LWESG 30		○	0.67	6.85	48	11	18	70	50	10	78	—	41.6	90	M 8×12	10	34	28	9	14	12	20	80	M 8×30	29 900	26 800	412	176 1 190	162 1 100
MESC 35	LWESC 35	○	6									111	50	74.6	123											42 900	44 700	686	448 2 660	412 2 450
MES 35	LWES 35	○	7									110	50	76.6	122											30 500	37 600	687	482 2 550	482 2 550
MES 35...SL	LWES 35...SL	○	7									110	50	76.6	122											30 500	37 600	687	482 2 550	482 2 550
MES 45	LWES 45		○	2.05	11.2	60	14	20.5	86	60	13	125	60	81.4	136	M10×15	13	45	34	11	17.5	14	22.5	105	M10×35	61 100	60 200	1 210	672 4 070	618 3 750

Notes (1) Track rail lengths L are shown in Tables 2.1 and 2.2 on page II - 67.
 (2) Track rail mounting bolts are not appended. Hexagon socket head bolts of JIS B 1176 with strength division 12.9 are recommended.
 (3) The direction of basic dynamic load rating (C), basic static load rating (C₀), and static moment rating (T₀, T_x, T_y) are shown in the sketches below. The upper values of T_x and T_y are for one slide unit and the lower values are for two slide units in close contact.
 (4) The shapes of grease nipple vary by size. The specifications are shown in Table 15 on page II - 73.

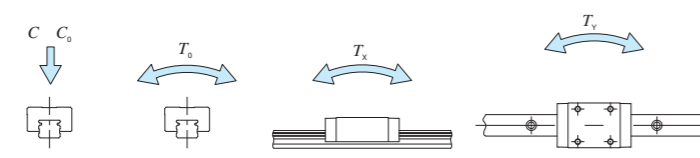

Example of identification number of assembled set

Model code	Dimensions	Part code	Model code	Material code	Preload symbol	Classification symbol	Interchangeable code	Supplemental code
MES	G	30	C2	R440	T1	P		/U
1	2	3	4	5	6	7	8	9
1 Model	2 Length of slide unit	3 Size	4 Number of slide unit (2)	5 Length of track rail (440 mm)	6 Material type	7 Preload amount	8 Accuracy class	9 Interchangeable
MES LWES LWES...Q	C Short No symbol Standard G Long	25, 30, 35, 45			No symbol High carbon steel made SL Stainless steel made	T ₀ Clearance No symbol Standard T ₁ Light preload T ₂ Medium preload	No symbol Ordinary H High P Precision SP Super precision	No symbol Non-interchangeable specification S1 S1 specification S2 S2 specification
								A, BS, D, E, F, I, J, L, LF, MA N, Q, RE, T, U, V, W, Y, Z