

LINEAR GUIDE

ROLLER GUIDE RA SERIES



The fruits of comprehensive technology of NSK. RA series roller guides handle a diversity of applications

The RA series of roller guides is the product of a combination of NSK's extensive experience in roller bearings and linear guide technologies. The result is an optimal design that takes full advantage of NSK's unique expertise to realize super-high load capacity, rigidity and motion accuracy, plus smooth motion. Capable of handling a variety of applications, the RA series supports high machine performance.

RA series features support high machine performance

Super-long Life

Super-high load capacity

NSK has realized super-high load capacity, now the highest performance in the world, and achieved unprecedented operating life.

Maintenance-free

Installing an NSK K1 lubrication unit assures long-term, maintenance-free operation.

Highly dust-proof

The high performance seals as standard equipment completely block the entry of foreign matter and maintain primary performance over the long term.

Contribution to High-precision Manufacturing

Super-high rigidity

Super-high rigidity provides high-precision manufacturing.

Super-high motion accuracy

Coupled with NSK's unique design approach, the vibration caused by roller passage has been substantially reduced. This will greatly contribute to improve machining quality.

Smooth motion

The installation of a retaining piece achieves smooth motion, resulting in stable positioning accuracy.

The RA series is available in eight models:

RA15, 20, 25, 30, 35, 45, 55 and 65.

Used in Many Fields

Complete series

Series includes a full lineup from small to large, including low-profile sizes. You can choose the model according to the application.

Interchangeable mounting dimensions

Outside dimensions and mounting dimensions conform to standard dimensions for the market, so RA series roller guides can be used without having to alter machine design. (See page 13 for mounting surface dimensions)

Low friction

Uses rollers for rolling elements to hold down dynamic friction.

Roller Guide RA Series

Optimal Design

NSK executed a comprehensive, detailed performance simulation of roller guides by integrating its analysis technology and the tribology technology that the company had been developing over many years.

Down to the dimensions and shapes of component details, we have attained an optimal design completely

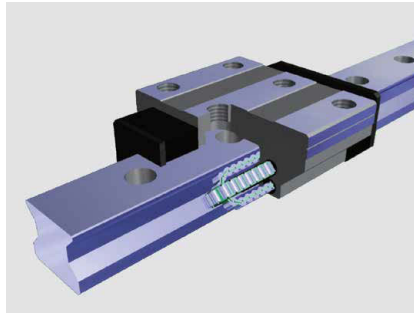

Smooth motion by use of retaining pieces

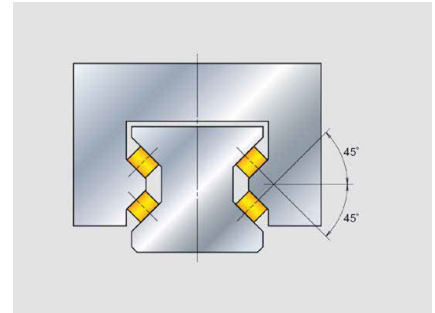

Balanced four-directional iso-load specifications

Random-matching Type RA25, 30, 35, 45, 55, 65 Random matching of rails and roller slides

Accuracy compatibility

The random combinations of roller slide and rail achieve high precision grade (PH) running parallelism.

Random matching with preload

The random combinations of roller slide and rail provide the constant rigidity with an adequate preload.

Random matching

The rails and roller slides can be selected in single unit quantities.

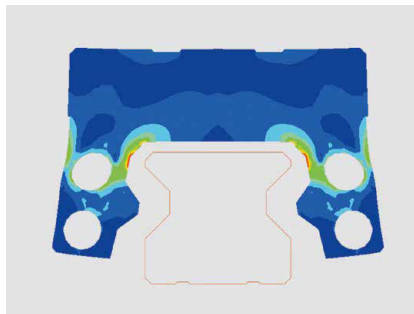

Example of roller slide deformation analysis

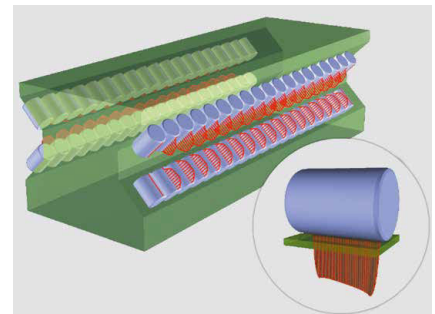

Analysis example of contact pressure distribution of rollers

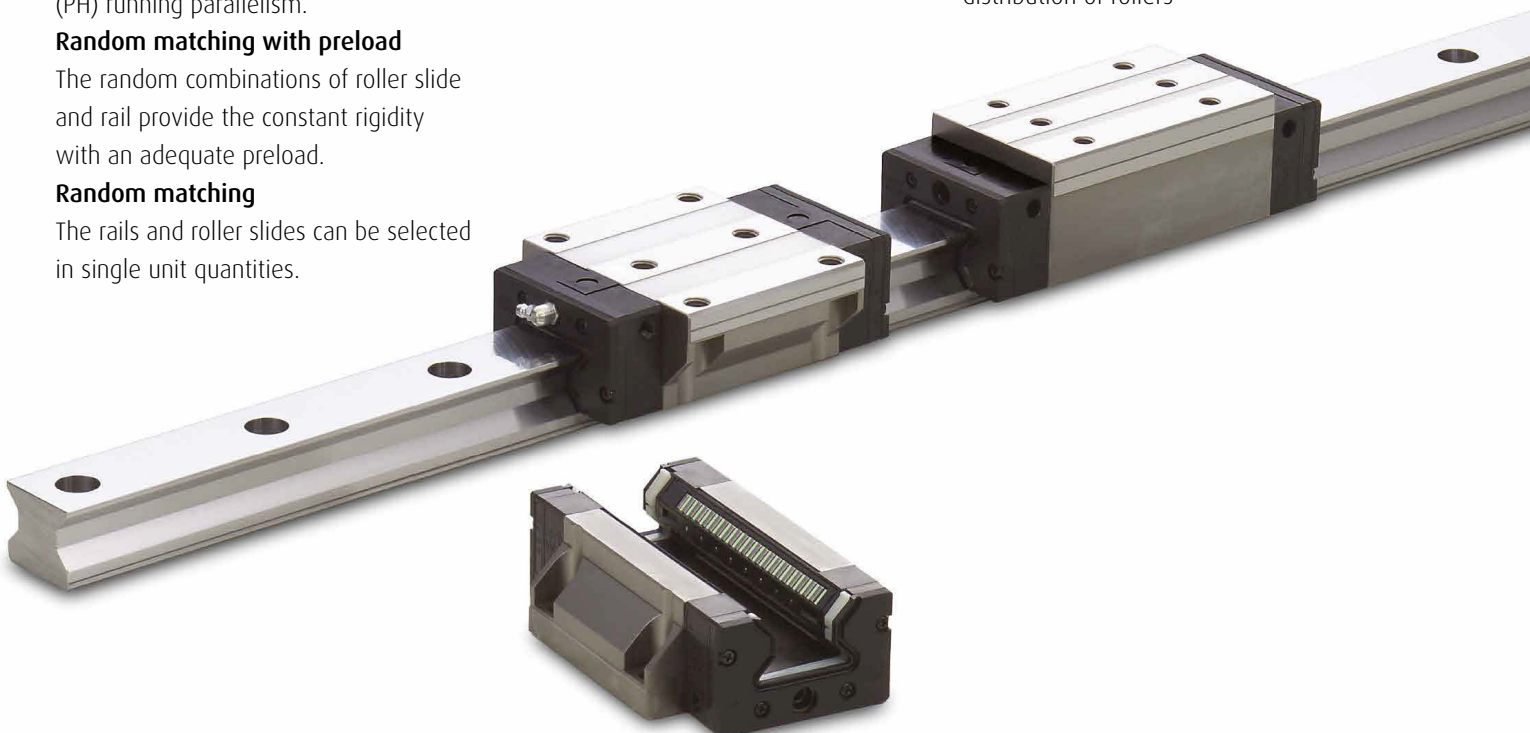

A variety of contributions to improve the performance of machine

far superior to conventional roller guides. Super-long life is achieved and impact load can be sufficiently handled.

Features

1. Super-high load capacity

By installing rollers that are the largest possible diameter and length within the existing standard cross-section dimension in a rational layout based on analysis technology, we have realized the world's highest load capacity*, far superior to conventional roller guides. Super-long life is achieved and impact load can be sufficiently handled.

* Compared with products of the same size, as of September 1, 2003, researched by NSK.

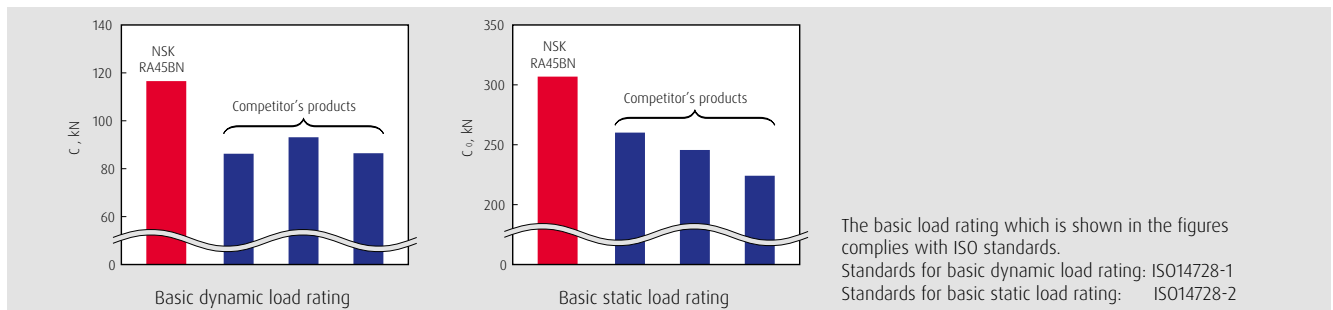

2. Super-high rigidity

Using NSK's advanced analysis technology, we pursued a complete, optimal design, down to the detailed shape of roller slides and rails, thereby realizing super-high rigidity superior to that of competitor's roller guides.

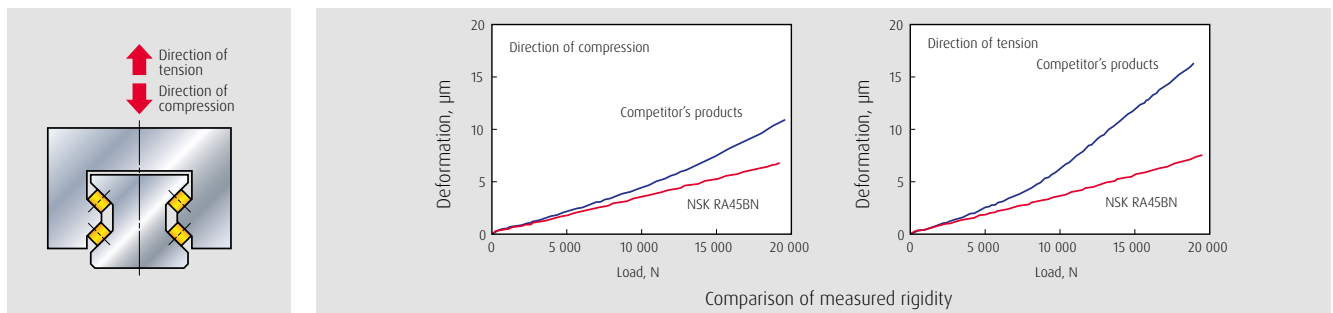

3. Super-high motion accuracy

NSK has developed its own unique method of simulating rolling element passage vibration and method of designing optimal roller slide specifications for damping roller passage vibration. These developments have dramatically enhanced roller slide motion accuracy for the RA series.

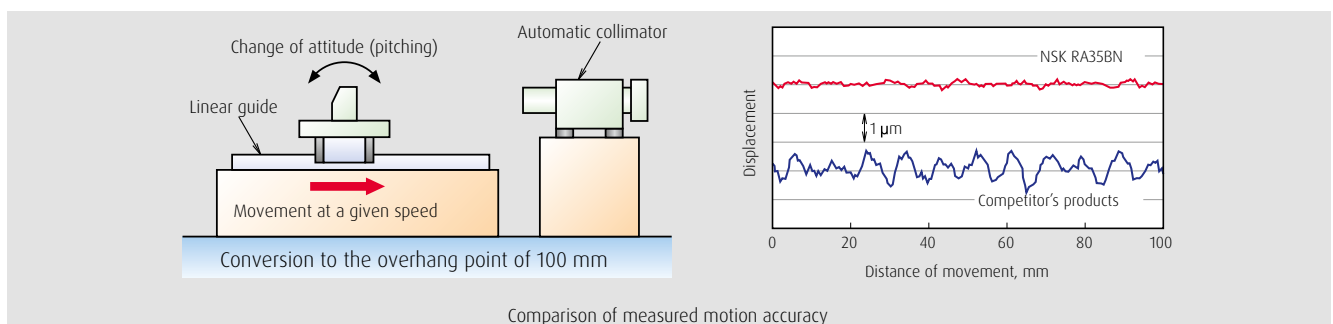

4. Mounting dimensions compatibility

The outer and mounting dimensions of RA series are based on market standards. RA series can be replaced without altering equipment design. (See page 13 for mounting surface dimensions)

Roller Guide RA Series

5. Smooth motion

Installing a retaining piece between rollers and restraining the skew peculiar to roller bearings achieve smooth motion. The reduction of friction variation provides stable tracking in the complicated trajectory control.

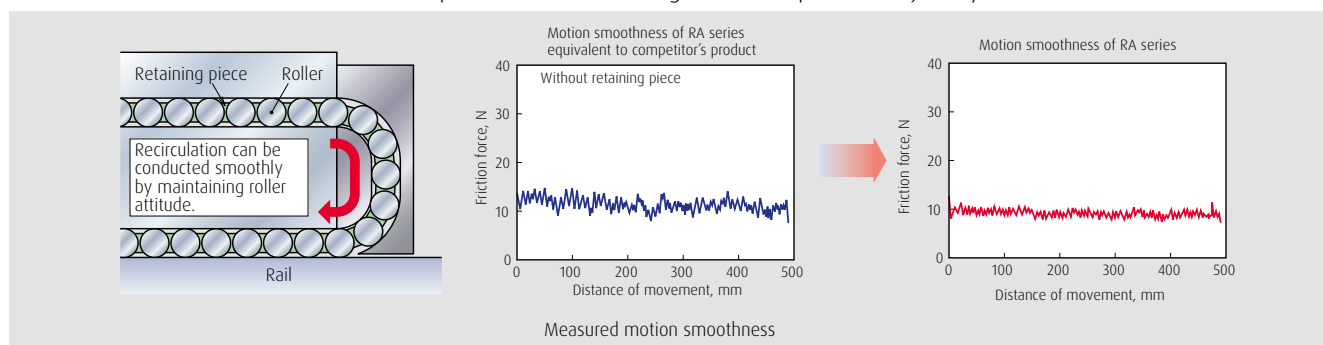

6. Low friction

Using rollers for rolling elements helps minimize dynamic friction.

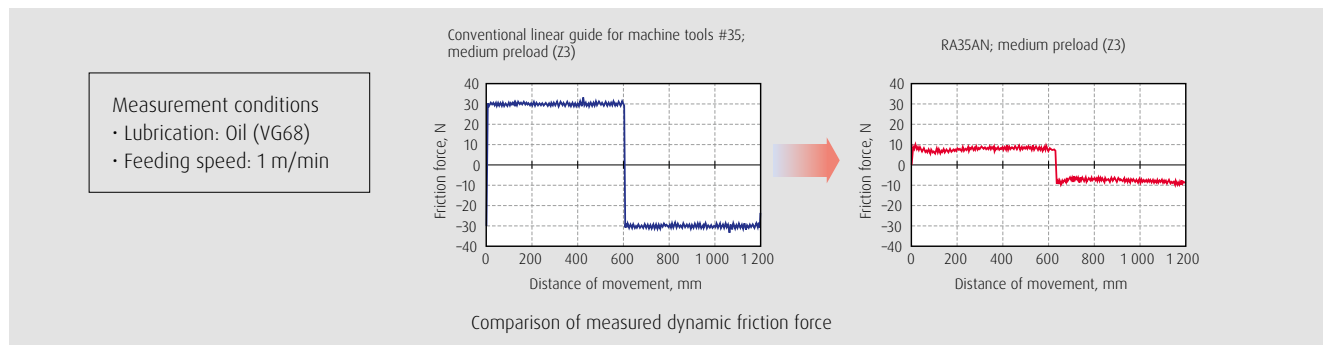

7. Low noise

A retaining piece is provided between rollers to prevent collision of rollers to minimize noise.

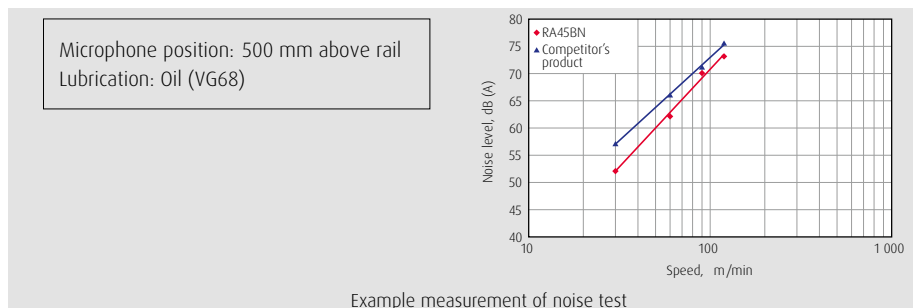

8. Highly dust-proof and maintenance-free operation

Various seals of roller slide, bolt-hole cap, and rail cover are available as options. Highly dustproof V1 seal and V1 bottom seal with excellent dustproof performance are also available. The highly regarded NSK K1 lubrication unit is also available to satisfy customer needs for long-term, maintenance-free operation. (Availability of some options depends on size. Please confirm details of dustproof specifications on page 11.)

Abundant variations to meet a wide variety of needs

Specifications

1. Roller Slide Types and Shapes

- › Two types of roller slides are available in this series: one with a mounting flange and a square type with tapped with holes and no flange.
- › A compact, low-profile square type is now available.
- › On the mounting hole of the flange type, the tapped part is used to fix the roller slide from the top surface, and the minor diameter can be used as a bolt hole from the bottom. This provides mounting from both directions, top and bottom.
- › Roller slide length can be specified by standard high load type or special long, super-high load type.

Fig. 1 Square type

Roller slide shape code

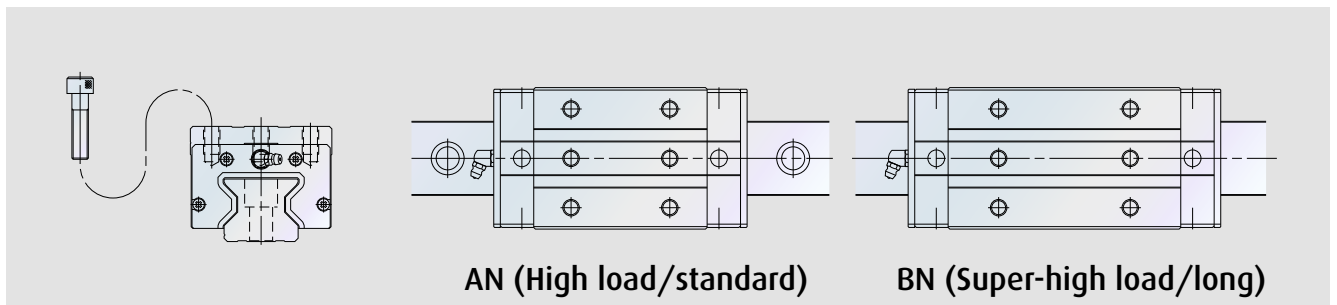

Fig. 2 Low-profile type

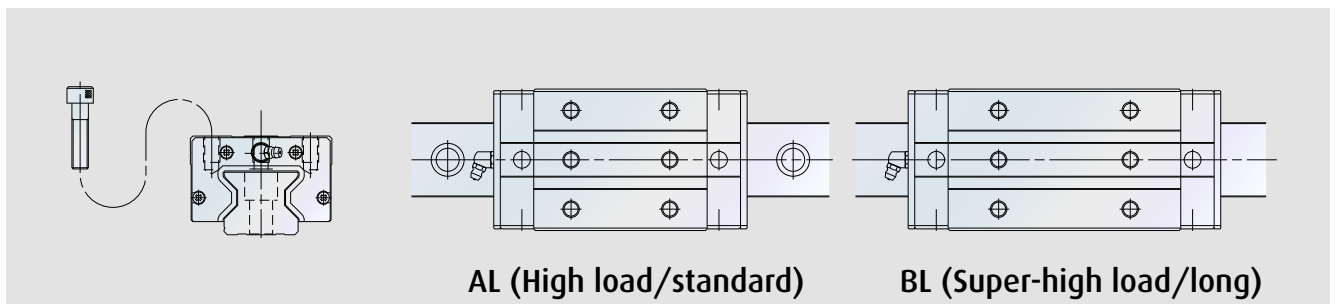
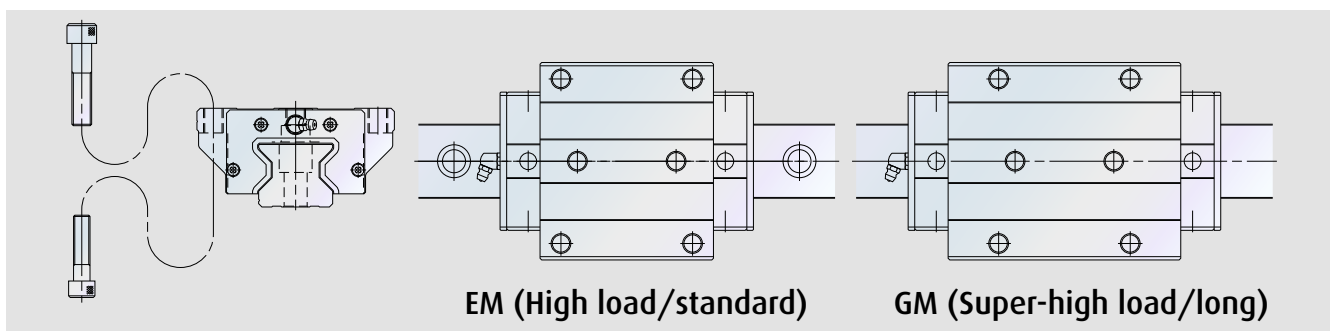

Fig. 3 Flange type



Roller Guide RA Series

2. Accuracy

The preloaded assembly has four accuracy grades; Ultra precision P3, Super precision P4, High precision P5, and Precision P6 grades, while the random-matching type has High precision PH grade only.

Table 1 Tolerance of preloaded assembly

Unit: μm

Characteristics	Ultra precision P3	Super precision P4	High precision P5	Precision grade P6
Mounting height H Variation of H (All roller slides on a set of rails)	± 8 3	± 10 5	± 20 7	± 40 15
Mounting width W_2 or W_3 Variation of W_2 or W_3 (All roller slides on reference rail)	± 10 3	± 15 7	± 25 10	± 50 20
Running parallelism of surface C to surface A Running parallelism of surface D to surface B	See Table 3 and Fig. 4			

Table 2 Tolerance of random-matching type

Unit: μm

Characteristics	High precision PH
Mounting height H	± 20
Variation of mounting height H	15 ① 25 ②
Mounting width W_2 or W_3	25 ②
Variation of mounting height H	± 25
Running parallelism of surface C to surface A Running parallelism of surface D to surface B	See Table 3 and Fig. 4

Note: " Variation on the same rail # Variation on multiple rails

Table 3 Running parallelism

Unit: μm

Rail length (mm)	Ultra precision P3	Super precision P4	High precision P5, PH	Precision grade P6
Over - 50 or less	2	2	2	4
50 - 80	2	2	3	4
80 - 125	2	2	3	4
125 - 200	2	2	3.5	5
200 - 250	2	2.5	4.5	6
250 - 315	2	2.5	5	6.5
315 - 400	2	3	5.5	7
400 - 500	2	3	6	7.5
500 - 630	2	3.5	6.5	8.5
630 - 800	2	4	7	9.5
800 - 1 000	2.5	4.5	7.5	10
1 000 - 1 250	3	5	8.5	12
1 250 - 1 600	3.5	5.5	9.5	13
1 600 - 2 000	4	6.5	11	14
2 000 - 2 500	4.5	7.5	12	16
2 500 - 3 150	5.5	8.5	13	18
3 150 - 3 500	6	9.5	14	19

Fig. 4 Specifications of accuracy

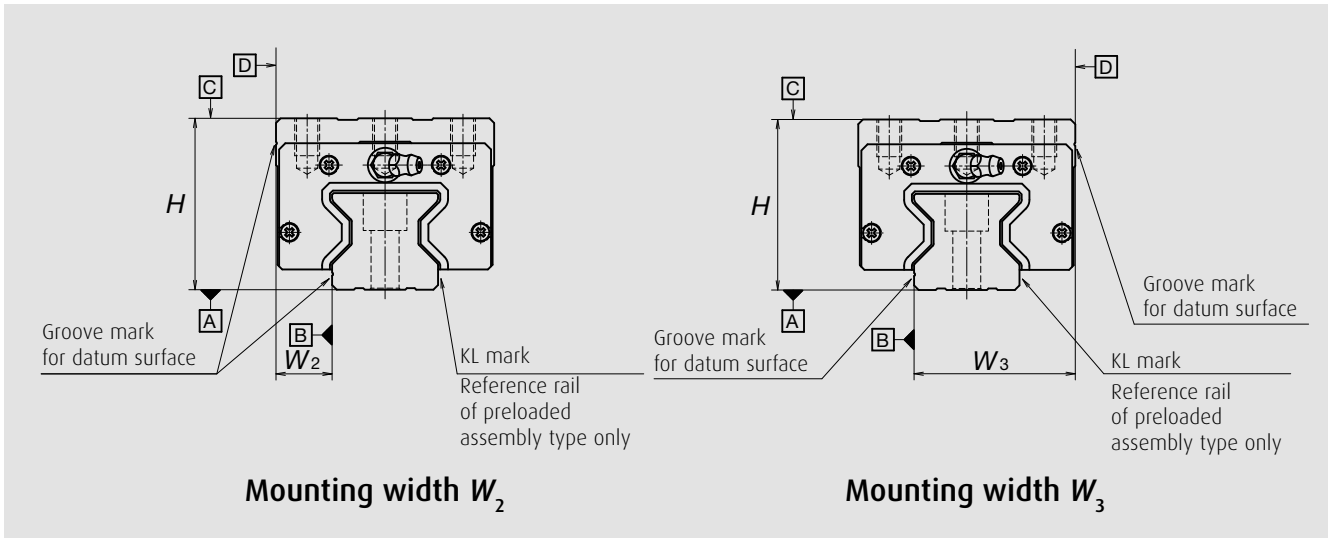

3. Preload and Rigidity

Medium preload Z3 and slight preload Z1 are available for preloaded assembly. Medium preload ZH and slight preload ZZ are available for random-matching type. Typical measurement data of preload and rigidity are shown below.

Table 4 Preload

Unit: N

Model No.	High-load type		Super-high-load type	
	Slight preload (Z1)	Medium preload (Z3)	Slight preload (Z1)	Medium preload (Z3)
RA15	-	1 030	-	1 300
RA20	-	1 920	-	2 400
RA25	880	2 920	1 060	3 540
RA30	1 170	3 890	1 430	4 760
RA35	1 600	5 330	2 020	6 740
RA45	2 780	9 280	3 500	11 600
RA55	3 800	12 900	5 000	16 800
RA65	6 500	21 000	8 500	28 800

Roller Guide RA Series

Fig. 5 Vertical direction theoretical rigidity line

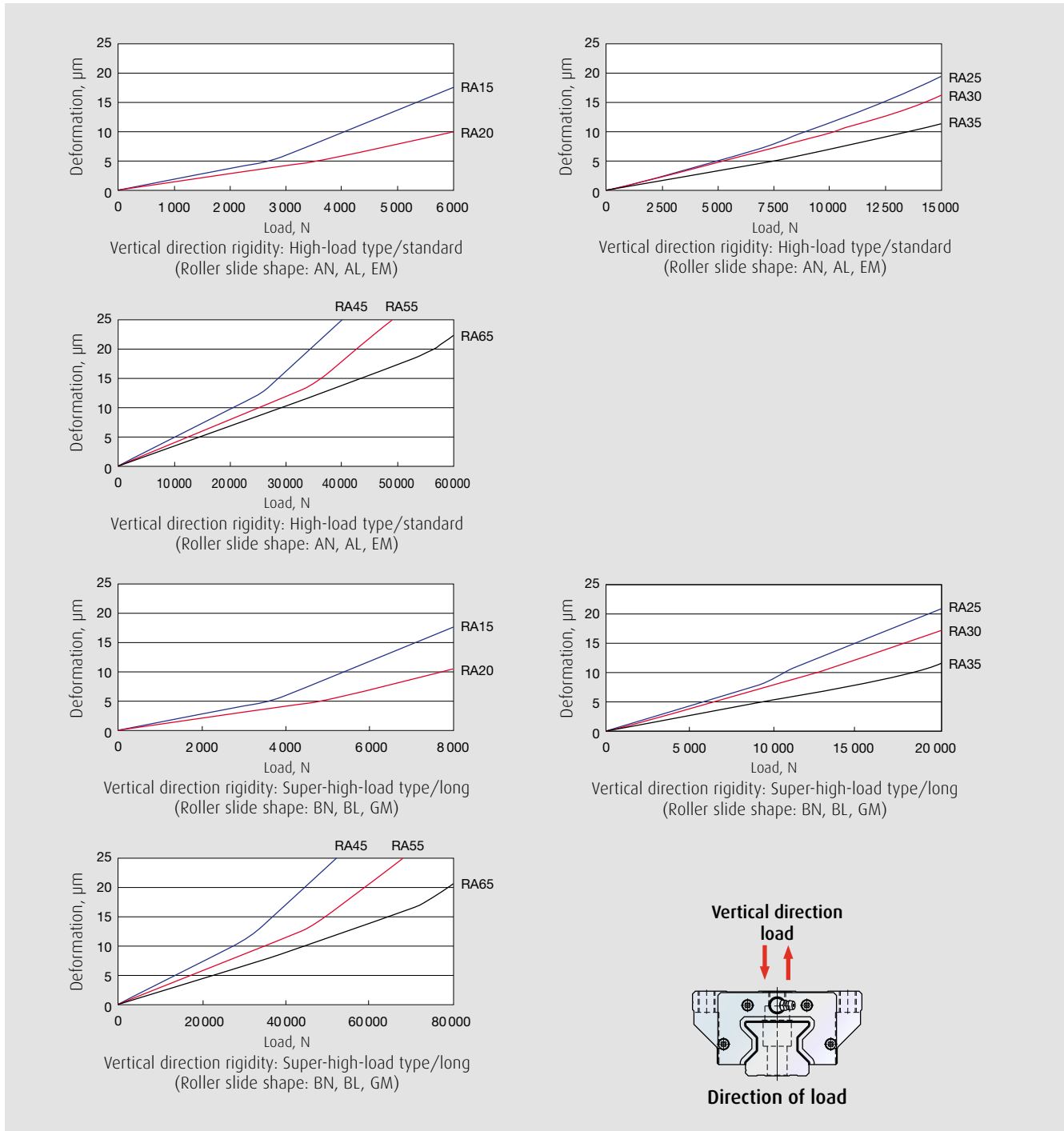

4. Basic Load Rating and Rated Life

Basic dynamic load rating that expresses load capacity is established by ISO standards (ISO14728-1) for linear guides. With basic dynamic load rating, direction and size do not fluctuate so that rated fatigue life is 100 km. Load rating for NSK Linear Guide complies with ISO standards. With the RA series, dynamic load rating is the same in both the vertical and horizontal directions (4-way equal load specs.). Rated fatigue life L is calculated by the following formula when load F is applied to the roller slide in the horizontal or vertical direction only.

- › This life formula is different from that for linear guides with ball rolling elements.
- › f_w is load factor. Refer to the respective value from the following table 4 as a guideline according to potential vibration and the impact of the machine in which the linear guide is used, and select the load factor.

$$L = 100 \times \left(\frac{C}{f_w \cdot F} \right)^{\frac{10}{3}} \text{ (km)}$$

Table 5 Load factor f_w

Impact and/or vibration	Load factor
No impact and vibration from the outside	1.0 - 1.5
With impact and/or vibration from the outside	1.5 - 2.0
With heavy impact and/or vibration from the outside	2.0 - 3.0

Load applied to the linear guide (ball slide load) comes from various directions up/down and right/left directions and/or as moment load. Sometimes more than one type of load is applied simultaneously. Sometimes volume and direction of the load may change.

Varying load cannot be used as it is to calculate life of linear guide. Therefore, it is necessary to use a hypothetical load to ball slide with a constant volume, which would generate a value equivalent to an actual fatigue life. This is called "dynamic equivalent load." For actual calculation, use the loads of Table 6.

Fig. 6 Direction of load

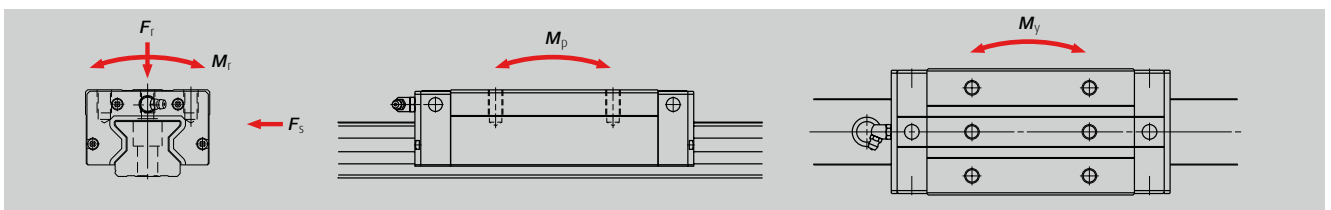

Roller Guide RA Series

Table 6 Loads in the arrangement of linear guide

Pattern	Arrangement of linear guide	Loads necessary to calculate dynamic equivalent load					Dynamic equivalent load
		Load		Moment load			
		Up/down (vertical)	Right/left (lateral)	Rolling	Pitching	Yawing	
1		F_r	F_s	M_r	M_p	M_y	$F_r = F_r$ $F_{se} = F_s \tan \alpha$ $F_{re} = \epsilon_r M_r$ $F_{pe} = \epsilon_p M_p$ $F_{ye} = \epsilon_y M_y$ α : Contact angle (=45°) Dynamic equivalent coefficient ϵ_r : Rolling direction ϵ_p : Pitching direction ϵ_y : Yawing direction
2		F_r	F_s	M_r			
3		F_r	F_s		M_p	M_y	
4		F_r	F_s				

Table 7 Dynamic equivalent coefficient

Model No.	Dynamic equivalent coefficient (1/m)		
	ϵ_r	ϵ_p	ϵ_y
RA15 High load type	105	95	95
RA15 Super-high load type	105	70	70
RA20 High load type	79	74	74
RA20 Super-high load type	79	55	55
RA25 High load type	71	64	64
RA25 Super-high load type	71	50	50
RA30 High load type	56	58	58
RA30 Super-high load type	56	44	44
RA35 High load type	46	52	52
RA35 Super-high load type	46	39	39
RA45 High load type	37	40	40
RA45 Super-high load type	37	30	30
RA55 High load type	32	33	33
RA55 Super-high load type	32	24	24
RA65 High load type	26	28	28
RA65 Super-high load type	26	19	19

Formula is determined by the relationship of loads in terms of volume. Full dynamic equivalent load can be easily obtained by using each coefficient.

After obtaining the dynamic equivalent of the necessary load directions from Table 6, use the formulas below to calculate full dynamic equivalent loads.

- When F_r is the largest load: $F_e = F_r + 0.5F_{se} + 0.5F_{re} + 0.5F_{pe} + 0.5F_{ye}$
- When F_{se} is the largest load: $F_e = 0.5F_r + F_{se} + 0.5F_{re} + 0.5F_{pe} + 0.5F_{ye}$
- When F_{re} is the largest load: $F_e = 0.5F_r + 0.5F_{se} + F_{re} + 0.5F_{pe} + 0.5F_{ye}$
- When F_{pe} is the largest load: $F_e = 0.5F_r + 0.5F_{se} + 0.5F_{re} + F_{pe} + 0.5F_{ye}$
- When F_{ye} is the largest load: $F_e = 0.5F_r + 0.5F_{se} + 0.5F_{re} + 0.5F_{pe} + F_{ye}$

For the values of each dynamic equivalent load in the formulas above, disregard load directions and take the absolute value.

5. Lubrication Specifications

(1) Types of lubrication accessories

› Fig. 9 and Table 9 show grease fittings and tube fittings.

(2) Mounting position of lubrication accessories

- › The standard position of grease fittings and tube fittings is the end face of roller slide. We can mount them on a side of end cap for an option. (Fig. 7) Please consult NSK for installation of grease or tube fittings to the roller slide body or the side of end cap.
- › A lubrication hole can also be provided on the top of the end cap. Fig. 8 and Table 8 show the mounting position. A spacer is required for AN and BN shape roller slides. The spacers are available from NSK.
- › When using a piping unit with a thread of M6 × 1, a connector is required to connect the piping unit to a grease fitting mounting hole with M6 × 0.75. Connectors are available from NSK.

(3) Mounting position of lubrication accessories

- › If oil lubrication is used, the oil may not pervade the rolling surface in accordance with the roller slide mounting conditions such as upside down mounting and wall mounting. In these situations, consult with NSK.
- › When using an oil mist lubricating system, please confirm how much oil is needed for each outlet port.

Fig. 7 Mounting position of lubrication accessories

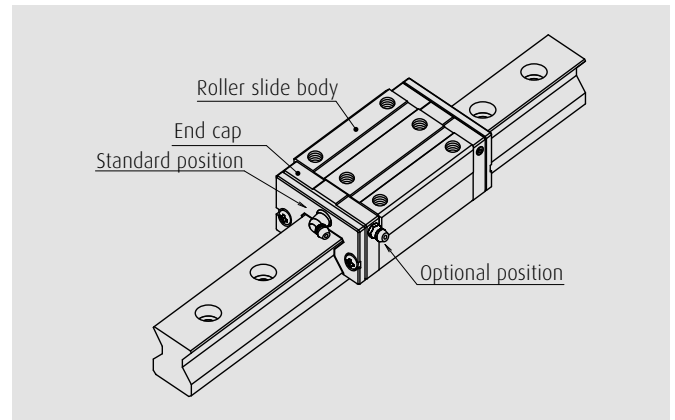

Fig. 8 Top and side lubrication hole positions

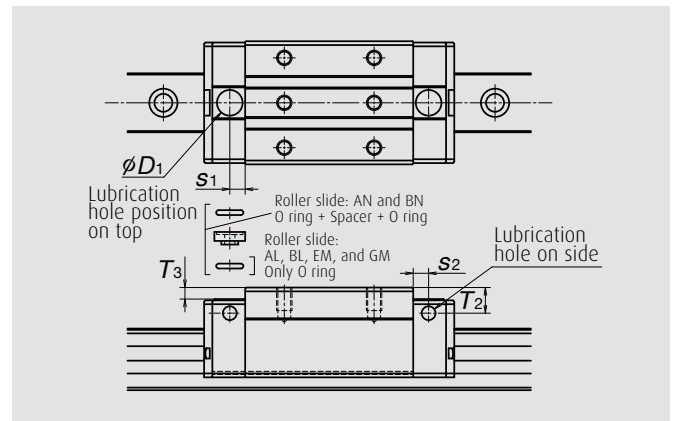

Table 8.1 Top and side lubrication hole position

Unit: mm

Model No.	Roller slide model	Grease fitting size	s_2	T_1	O ring (JIS)	Spacer	D_1	s_1	T_2
RA15	AN, BN	$\varnothing 3$	4	7	P5	Required	8.2	4.4	4.2
RA20		$\varnothing 3$	4	4	P6	-	9.2	5.4	0.2
RA25		M6×0.75	6	10	P7	Required	10.2	6	4.5
RA30		M6×0.75	5	10	P7+P5	Required	10.2	6	3.5
RA35		M6×0.75	5.5	15	P7+P5	Required	10.2	7	7.4
RA45		Rc 1/8	7.2	20	P7+P5	Required	10.2	7.2	10.4
RA55		Rc 1/8	7.2	21	P7+P5	Required	10.2	7.2	10.4
RA65		Rc 1/8	7.2	19	P7	-	10.2	7.2	0.4

Note: Grease fitting and tube fitting cannot be mounted on the top of the end cap.

Roller Guide RA Series

Table 8.2 Top and side lubrication hole position

Unit: mm

Model No.	Roller slide model	Grease fitting size	s ₂	T ₁	D ₁	s ₁	T ₂
RA15	AL, BL, EM, GM	∅ 3	4	3	8.2	4.4	0.2
RA20	EM, GM	∅ 3	4	4	9.2	5.4	0.2
RA25	AL, BL, EM, GM	M6×0.75	6	6	10.2	6	0.4
RA30		M6×0.75	5	7	10.2	6	0.4
RA35		M6×0.75	5.5	8	10.2	7	0.4
RA45		Rc 1/8	7.2	10	10.2	7.2	0.4
RA55		Rc 1/8	7.2	11	10.2	7.2	0.4
RA65		EM, GM	Rc 1/8	7.2	19	10.2	7.2

Note: Grease fitting and tube fitting cannot be mounted on the top of the end cap.

Fig. 9 Grease fitting and Tube fitting

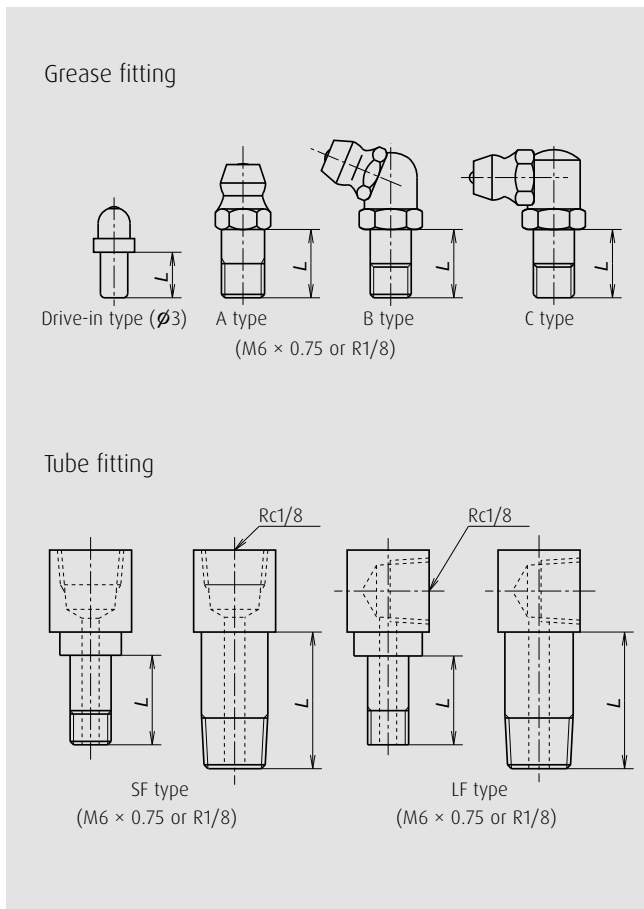

Table 9

Unit: mm

Model No.	Dust-proof specification	Dimension L		
		Grease fitting / Drive-in type	Tube fitting	
			SF type	LF type
RA15	Standard	5	-	-
	With NSK K1	10	-	-
	Double seal	8	-	-
	Protector	8	-	-
RA20	Standard	5	-	-
	With NSK K1	10	-	-
	Double seal	8	-	-
	Protector	10	-	-
RA25	Standard	5	5	5
	With NSK K1	12	12	12
	Double seal	10	9	9
	Protector	10	9	9
RA30	Standard	5	6	6
	With NSK K1	14	14	15
	Double seal	12	12	11
	Protector	12	10	11
RA35	Standard	5	6	6
	With NSK K1	14	14	15
	Double seal	12	12	11
	Protector	12	10	11
RA45	Standard	8	13.5	17
	With NSK K1	18	20	21.5
	Double seal	14	16	17
	Protector	14	16	17
RA55	Standard	8	13.5	17
	With NSK K1	18	20	21.5
	Double seal	14	16	17
	Protector	14	16	17
RA65	Standard	8	13.5	17
	With NSK K1	20	20	20
	Double seal	14	18	17
	Protector	14	16	17

6. Dust-proof

(1) Standard specification

The RA series is equipped with end, inner¹⁾ and bottom seals to prevent foreign matter from entering the inside of the roller slide. Under normal applications, the RA series can be used without modification. For severe usage conditions, optional rail covers and highly dustproof V1 seal are available. Contact NSK for information on how to mount the cover.

Fig. 10 View of the roller slide equipped with the dust-proof parts

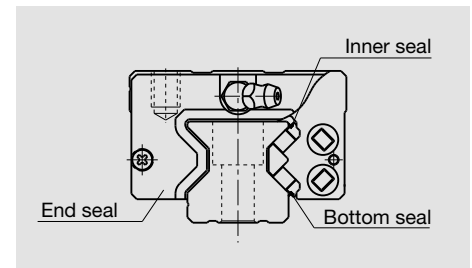

Table 10 Optional parts for dustproof

Name	Purpose
NSK K1 lubrication unit	Made of oil impregnated resin. Enhances lubricating functions.
Double seal	It combines two end seals for enhancing sealing function.
Protector	Protect the end seal from hot and hard contaminants.
Rail cap	Prevents foreign matters, such as swarf generated in cutting operation from clogging the rail-mounting holes.
Rail cover ²⁾	Covers the rail top surface, and prevents foreign matters, such as cutting dust, from collecting in the rail mounting holes.
Highly dustproof V1 seal ³⁾	An end seal that improves wear resistance maintains highly dustproof performance over a long period of time.
V1 bottom seal ⁴⁾	A bottom seal exhibits the high dustproof performance same as the highly dustproof V1 seal.

Fig. 11 Rail cover



¹⁾ Inner seals for the models of RA15 and RA20 are available as option.

²⁾ Rail cover is available for the models of RA25 to RA65.

³⁾ Highly dustproof V1 seal is available for the models of RA25 to RA65.

⁴⁾ V1 bottom seal is available for the models of RA35 to RA65.

Roller Guide RA Series

(2) NSK K1 lubrication unit

Table 11 shows the dimension of linear guides equipped with the NSK K1 lubrication unit.

Table 11

Unit: mm

Model No.	Roller slide length	Roller slide model	Standard roller slide length	With two NSK K1	Thickness of NSK K1 V_1	Protruding area of the grease fitting N
RA15	Standard	AN, AL, EM	70	79	4.5	(3)
	Long	BN, BL, GM	85.4	94.4		
RA20	Standard	AN, EM	86.5	95.5	4.5	(3)
	Long	BN, GM	106.3	115.3		
RA25	Standard	AN, AL, EM	97.5	107.5	5	(11)
	Long	BN, BL, GM	115.5	125.5		
RA30	Standard	AN, AL, EM	110.8	122.8	6	(11)
	Long	BN, BL, GM	135.4	147.4		
RA35	Standard	AN, AL, EM	123.8	136.8	6.5	(11)
	Long	BN, BL, GM	152	165		
RA45	Standard	AN, AL, EM	154	168	7	(14)
	Long	BN, BL, GM	190	204		
RA55	Standard	AN, AL, EM	184	198	7	(14)
	Long	BN, BL, GM	234	248		
RA65	Standard	AN, EM	228.4	243.4	7.5	(14)
	Long	BN, GM	302.5	317.5		

Note: Roller slide length equipped with NSK K1 = (Standard roller slide length) + (Thickness of NSK K1 Case Unit × Number of NSK K1 Case Unit)

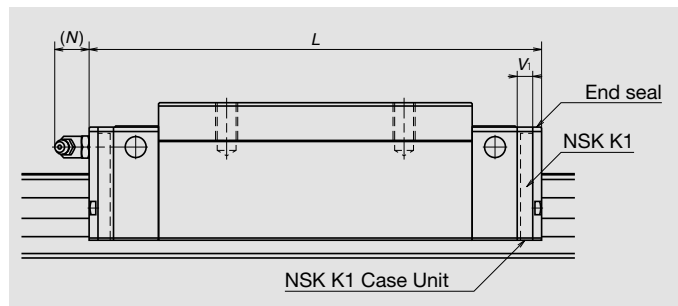

(3) Double seal and protector

For RA Series, double seal and protector can be installed only before shipping from the factory.

Table 12 shows the increased thickness when end seal and protector are installed.

Fig. 12

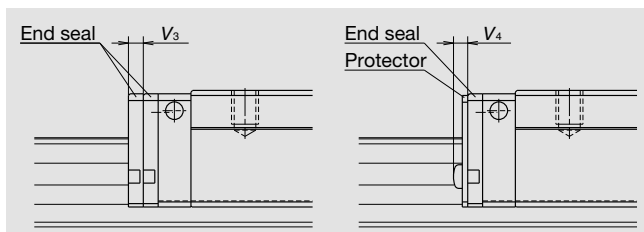

Table 12

Unit: mm

Model No.	Thickness of end seal V_3	Thickness of protector V_4
RA15	3	2.7
RA20	3	3.3
RA25	3.2	3.3
RA30	3.4	3.6
RA35	3.4	3.6
RA45	4	4.2
RA55	4	4.2
RA65	5	5.5

(4) Rail cover

When the rail cover is used, use the cover bracket to secure the rail cover. Fig. 13 shows the dimensions for the cover bracket. The required room at the end of the rail is:

- › Inside: 10.5 mm or less
- › Outside: 4 mm or less (Common to the models of RA25 to RA65)

Please confirm the interference with your machine at the stroke end.

- › Machine stroke
- › Room for the end of the rail

The height of the rail with the rail cover is shown in Table 13.

Fig. 13 End configuration of rail equipped with the rail cover

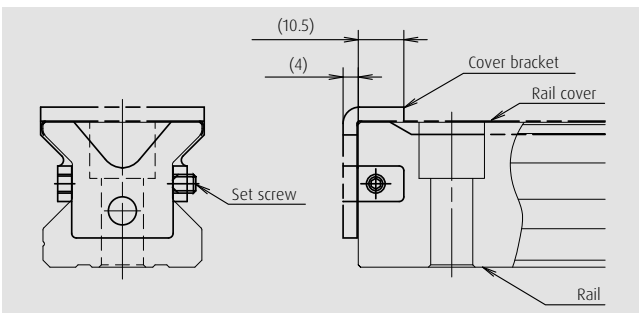

Table 13 Height of rails equipped with rail cover

Unit: mm

Model No.	Standard rail height H_1	Rail height installed with rail cover
RA25	24	24.25
RA30	28	28.25
RA35	31	31.25
RA45	38	38.3
RA55	43.5	43.8
RA65	55	55.3

(5) Cap to plug the rail mounting bolt hole

Table 14 Cap to plug rail mounting bolt hole

Model No.	Bolt to secure rail	Cap reference No.	Quantity/case
RA15	M4	LG-CAP/M4	20/case
RA20	M5	LG-CAP/M5	20/case
RA25	M6	LG-CAP/M6	20/case
RA30, RA35	M8	LG-CAP/M8	20/case
RA45	M12	LG-CAP/M12	20/case
RA55	M14	LG-CAP/M14	20/case
RA65	M16	LG-CAP/M16	20/case

Bolt size for rail mounting and cap reference number are shown in Table 14.

Roller Guide RA Series

(6) Specification with highly dustproof V1 seal and V1 bottom seal

RA25, RA30, RA35, RA45, RA55, and RA65 also have the specification with newly developed, highly dustproof V1 seal which is the end seal with enhanced abrasion resistance. Highly dustproof V1 seal made of new materials and in a new shape for better abrasion resistance prevents foreign matter getting into the roller slide for a long period.

RA35, RA45, RA55, and RA65 also have prepared highly dustproof V1 bottom seal. In addition, outstanding lubrication effects by NSK K1 further improves the durability.

High dustproof V1 bottom seal and NSK K1 can be selected individually according to the application.

The bolt hole caps whose shape is partly changed eliminate building up of foreign matter in and around the rail mounting holes and prevent foreign matter from entering into the roller slide. Otherwise, the rail cover with higher dustproofness can be selected.

Table 15 shows the dimensions of roller slides equipped with V1 seal and V1 bottom seal.

Fig. 14

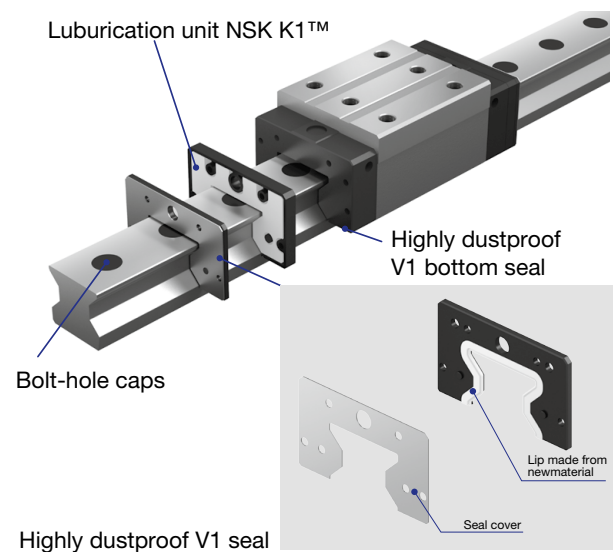

Table 15

Unit: mm

Model No.	Roller slide length	Roller slide type	Standard roller slide length L	Roller slide length equipped with V1 seal and NSK K1 L	Slide bottom face height equipped with V1 bottom seal E V1	Thickness of V1 seal V0	Thickness of K1 case unit V1
RA25	Standard	AN, AL, EM	97.5	111.3	-	5.1	5
	Long	BN, BL, GM	115.5	129.3			
RA30	Standard	AN, AL, EM	110.8	126.8	-	5.4	6
	Long	BN, BL, GM	135.4	151.4			
RA35	Standard	AN, AL, EM	123.8	140.8	min 3.7	5.4	6.5
	Long	BN, BL, GM	152	169			
RA45	Standard	AN, AL, EM	154	173.2	min 5.2	6.6	7
	Long	BN, BL, GM	190	209.2			
RA55	Standard	AN, AL, EM	184	203.2	min 6.2	6.6	7
	Long	BN, BL, GM	234	253.2			
RA65	Standard	AN, EM	228.4	251.2	min 10.2	8.9	7.5
	Long	BN, GM	302.5	325.3			

The detailed contents of the high dustproof V1 seal and V1 bottom seal are introduced in the catalog "CAT No. 3334" of NSK Linear Guide Roller Guides with highly dustproof V1 seal and V1 bottom seals.

Use of linear guides in a contaminated environment

- (1) Using a linear guide in a contaminated environment has serious effects on lubrication condition and durability of the linear guide. We recommend evaluation tests with your specific application.
- (2) If use in a contaminated environment is expected, fill in the technical data sheet for linear guides in contaminated environments.
(Please consult NSK for the details of the technical data sheet.)

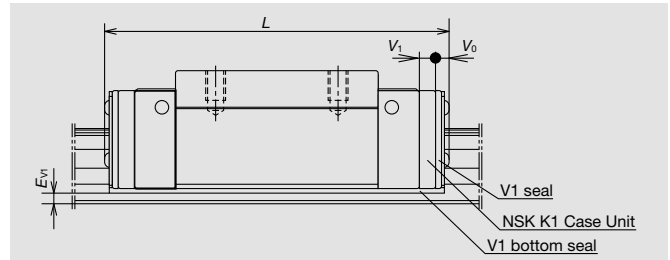

(7) Maximum rail length

Table 16 shows the limitations of rail length (maximum length). However, the limitations vary by accuracy grades.

Table 16 Length limitation of rails

Unit: mm

Size	RA15	RA20	RA25	RA30	RA35	RA45	RA55	RA65
Maximum length	2 000	3 000	3 900	3 900	3 900	3 650	3 600	3 600

Note: Rails can be butted if user requirement exceeds the rail length shown in the table.
Please consult NSK.

Roller Guide RA Series

8. Installation

(1) Mounting tolerance

Mounting tolerance results in harmful effects such as shortened operating life, deterioration in motion accuracy, and friction variation.

NSK particularly focuses on operating life, and sets an operating life value of more than 10 000 km calculated under the following conditions as mounting tolerance:

- › The load per roller slide is 10% of basic dynamic load rating C.
- › The rigidity of machine is infinite.

The tolerance in Fig. 15 is shown in the Table 17 as typical tolerance.

Fig. 15 Mounting tolerance

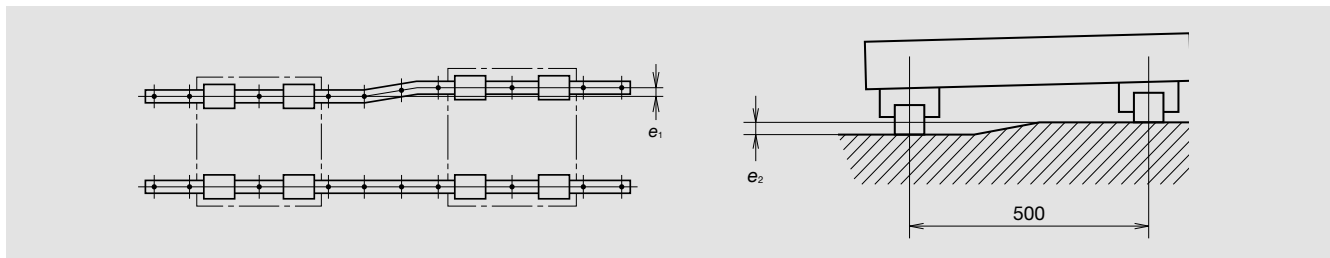

Table 17 Mounting tolerance

Unit: μm

Value	Preload	Model No.							
		RA15	RA20	RA25	RA30	RA35	RA45	RA55	RA65
Permissible values of parallelism in two rails e_1	Z1, ZZ	-	-	14	18	21	27	31	49
	Z3, ZH	5	7	9	11	13	17	19	30
Permissible values of parallelism (height) in two rails e_2	Z1, ZZ	290 μm /500mm							
	Z3, ZH	150 μm /500mm							

(2) Shoulder height and corner radius of mounting surface

Fig. 16 and Table 18 show shoulder height and corner radius of the mounting surface, when the rail or the roller slide is pressed to the shoulder of the machine base or table (the raised section from where the mounting surface begins) and fixed horizontally.

Fig. 16 Datum face of roller guide and shoulder

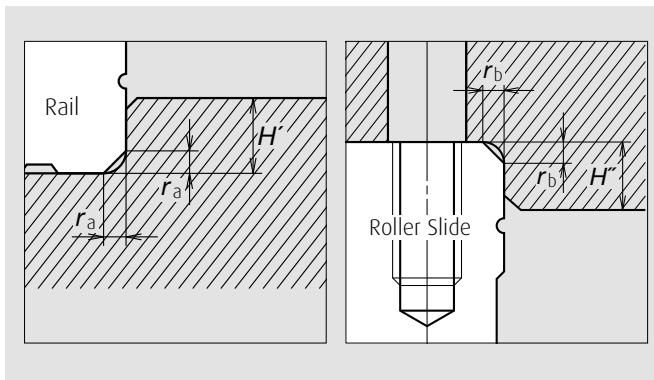

Table 18 Shoulder height and corner radius of attachment

Unit: mm

Model No.	Shoulder Height		Chamfer (maximum)	
	H'	H''	r _a	r _b
RA15	3	4	0.5	0.5
RA20	4	5	0.5	0.5
RA25	4	5	0.5	1.0
RA30	5	6	1.0	1.0
RA35	5	6	1.0	1.0
RA45	6	8	1.5	1.0
RA55	7	10	1.5	1.5
RA65	11	11	1.5	1.5

Handling Precautions

- ① Operating temperature limits should normally be less than 80°C.
- ② If using NSK K1, service temperature should not exceed 50°C (or 80°C instantaneously). Make sure the unit does not come in contact with organic solvents with that can be used for degreasing. Do not place the unit in a location exposed to white kerosene or rust prevention oil containing white kerosene.
- ③ When transferring the roller slide onto the rail, or vice versa:
 - › Do not remove an unnecessary roller slide from the rail as much as you can.
 - › Use the provided provisional rail to prevent dents or scratches on the raceways caused by the roller slide that is jammed into the one from the other. It also prevents the rollers from dropping.
 - › When transferring the roller slide onto the rail, or vice versa, butt the provisional rail up against the rail and slide it directly from one onto the other.
 - › Use a clean provisional rail. Do not use the provisional rail that is contaminated with particles or uses different grease from that of the relevant roller slide.

RA Series dimension table

Square type (tapped mounting holes)
 RA-AN (High-load type/standard), RA-BN (Super-high-load type/long)

(1) Reference number for preloaded assembly

Series name: RA, Size: 35, Rail length (mm): 1000, Roller slide shape code AN, BN, Material and surface treatment code: C, Design serial number: 2, Accuracy code: ※※, Preload code: P6, Number of roller slides per rail: 3

Preload code: 1: Z1, 3: Z3, Z: ZZ, H: ZH
 Accuracy code: (Without NSK K1): P3, P4, P5, P6, PH (With NSK K1): K3, K4, K5, K6, KH
 Design serial number: Number of roller slides per rail

(2) Reference number for random-matching type

Roller slide: RAA, Size: 35, Roller slide shape code AN, BN, Material and surface treatment code: PH, H, Option code: -F

Random-matching roller slide series code: RAA: RA Series random-matching roller slide
 Size: Roller slide shape code AN, BN
 Option code: No code: No surface treatment, F: Fluoride low temperature chrome plating, -C: No surface treatment + Rail cover, -CF: Fluoride low temperature chrome plating + Rail cover
 Preload code: Z: Slight preload, H: Medium preload
 Accuracy code: PH, KH: High-precision grade random-matching type

Rail: R1A, Size: 35, Rail length (mm): 1000, Rail shape code L, Material and surface treatment code: C, Design serial number: N, Accuracy code: ※※, Preload code: PH, Z

Random-matching roller slide series code: RAA: RA Series random-matching roller slide
 Size: Rail length (mm): Rail shape code L: L: Standard
 Material and surface treatment code: Preload code: Z: Common for slight and medium preload
 Accuracy code: PH: High-precision grade random-matching
 Design serial number: Added to the reference number.
 *Butting rail specification
 N: Non-butting, L: Butting specification
 *Please consult with NSK for butting rail specification.

Model No.	Assembly			Roller slide											Width	Height		
	Height	E	W ₂	Width	Length	Mounting hole			L ₁	K	T	Grease fitting					W ₁	H ₁
						B	J	M × pitch × ℓ				Hole size	T ₁	N				
RA15AN RA15BN	28	4	9.5	34	70 85.4	26	26	M4×0.7×6	44.8 60.2	24	8	φ3	8	3	15	16.3		
RA20AN RA20BN	30	5	12	44	86.5 106.3	32	36 50	M5×0.8×6	57.5 77.3	25	12	φ3	4	3	20	20.8		
RA25AN RA25BN	40	5	12.5	48	97.5 115.5	35	35 50	M6×1×9	65.5 83.5	35	12	M6×0.75	10	11	23	24		
RA30AN RA30BN	45	6.5	16	60	110.8 135.4	40	40 60	M8×1.25×11	74 98.6	38.5	14	M6×0.75	10	11	28	28		
RA35AN RA35BN	55	6.5	18	70	123.8 152	50	50 72	M8×1.25×12	83.2 111.4	48.5	15	M6×0.75	15	11	34	31		
RA45AN RA45BN	70	8	20.5	86	154 190	60	60 80	M10×1.5×17	105.4 141.4	62	17	R _c 1/8	20	14	45	38		
RA55AN RA55BN	80	9	23.5	100	184 234	75	75 95	M12×1.75×18	128 178	71	18	R _c 1/8	21	14	53	43.5		
RA65AN RA65BN	90	13	31.5	126	228.4 302.5	76	70 120	M16×2×20	155.4 229.5	77	22	R _c 1/8	19	14	63	55		

Notes: 1) Select either one of two F dimensions, the standard or the parenthesized semi-standard dimension, for the pitch of rail fixing bolt holes. If not specified, the standard dimension of F is applied.

Roller Guide RA Series

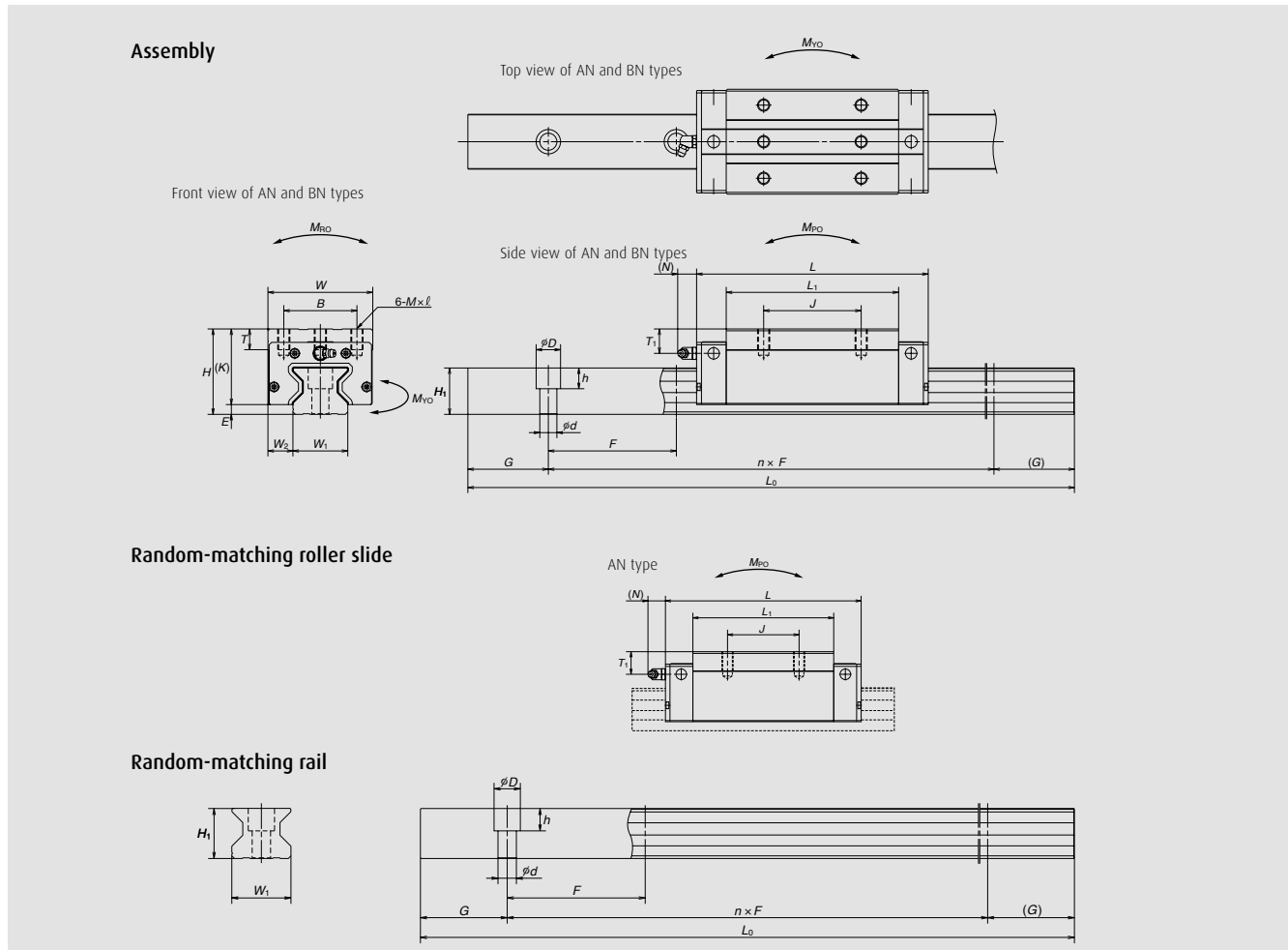

Unit: mm

Rail		G (reference)	Maximum length L_{0max}	Basic load rating								Weight	
Pitch F	Mounting bolt hole $d \times D \times h$			3) Dynamic		Static C_0 (N)	M_{R0}	Static moment (N·m)				Roller slide (kg)	Rail (kg/m)
				[50km] C_{50} (N)	[100km] C_{100} (N)			M_{p0}		M_{y0}			
						One slide	Two slides	One slide	Two slides				
60 (30)	4.5×7.5×5.3	20	2 000	12 600 16 000	10 300 13 000	27 500 37 000	260 350	210 375	1 320 2 130	210 375	1 320 2 130	0.21 0.30	1.6
60 (30)	6×9.5×8.5	20	3 000	23 600 29 500	19 200 24 000	52 500 70 000	665 890	505 900	3 100 5 000	505 900	3 100 5 000	0.38 0.50	
30 (60)	7×11×9	20	3 900	36 000 43 500	29 200 35 400	72 700 92 900	970 1 240	760 1 240	4 850 7 200	760 1 240	4 850 7 200	0.60 0.91	3.4
40 (80)	9×14×12	20	3 900	47 800 58 500	38 900 47 600	93 500 121 000	1 670 2 170	1 140 1 950	7 100 11 500	1 140 1 950	7 100 11 500	1.0 1.3	
40 (80)	9×14×12	20	3 900	65 500 82 900	53 300 67 400	129 000 175 000	2 810 3 810	1 800 3 250	11 000 17 800	1 800 3 250	11 000 17 800	1.6 2.1	6.8
52.5 (105)	14×20×17	22.5	3 650	114 000 143 000	92 800 116 000	229 000 305 000	6 180 8 240	4 080 7 150	24 000 39 000	4 080 7 150	24 000 39 000	3.0 4.1	
60 (120)	16×23×20	30	3 600	159 000 207 000	129 000 168 000	330 000 462 000	10 200 14 300	7 060 13 600	41 000 72 000	7 060 13 600	41 000 72 000	4.9 6.7	14.6
75 (150)	18×26×22	35	3 600	259 000 355 000	210 000 288 000	504 000 756 000	19 200 28 700	12 700 28 600	78 500 153 000	12 700 28 600	78 500 153 000	9.3 12.2	

2) The random-matching type is available for the models of RA25 to RA65.
 3) The basic load rating comply with the ISO standard. (ISO 14728-1, 14728-2)
 C_{50} : the basic dynamic load rating for 50 km rated fatigue life
 C_{100} : the basic dynamic load rating for 100 km rated fatigue life

RA Series dimension table

Low profile type (tapped mounting holes)

RA-AL (High-load type/standard), RA-BL (Super-high-load type/long)

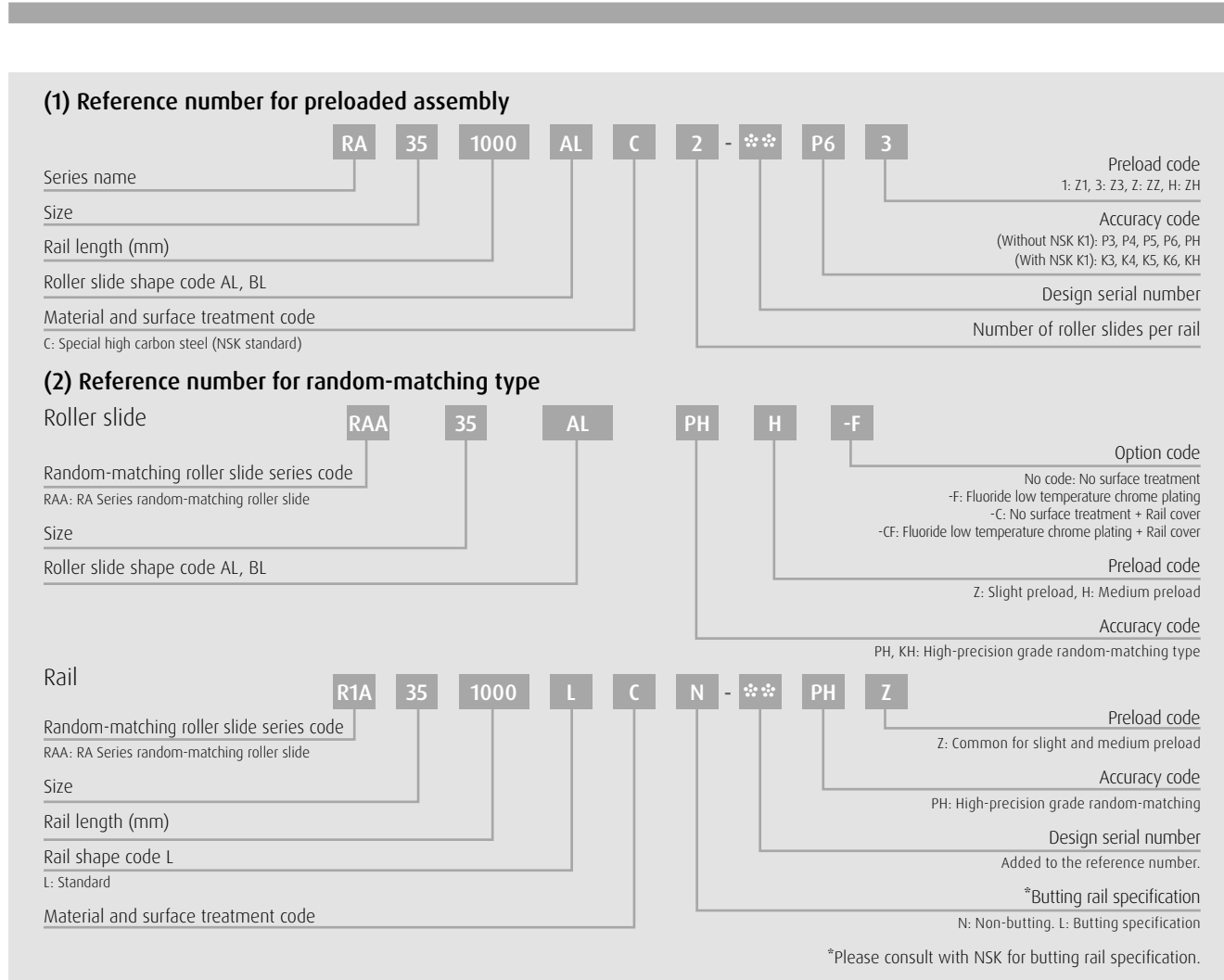

Model No.	Assembly			Roller slide											Width	Height		
	Height	E	W ₂	Width	Length	Mounting hole			L ₁	K	T	Grease fitting					W ₁	H ₁
						B	J	M × pitch × ℓ				Hole size	T ₁	N				
RA15AL RA15BL	24	4	9.5	34	70 85.4	26	26	M4×0.7×5.5	44.8 60.2	20	8	∅3	4	3	15	16.3		
RA25AL RA25BL	36	5	12.5	48	97.5 115.5	35	35 50	M6×1×8	65.5 83.5	31	12	M6×0.75	6	11	23	24		
RA30AL RA30BL	42	6.5	16	60	110.8 135.4	40	40 60	M8×1.25×11	74 98.6	35.5	14	M6×0.75	7	11	28	28		
RA35AL RA35BL	48	6.5	18	70	123.8 152	50	50 72	M8×1.25×12	83.2 111.4	41.5	15	M6×0.75	8	11	34	31		
RA45AL RA45BL	60	8	20.5	86	154 190	60	60 80	M10×1.5×16	105.4 141.4	52	17	R _c 1/8	10	14	45	38		
RA55AL RA55BL	70	9	23.5	100	184 234	75	75 95	M12×1.75×18	128 178	61	18	R _c 1/8	11	14	53	43.5		

Notes: 1) Select either one of two F dimensions, the standard or the parenthesized semi-standard dimension, for the pitch of rail fixing bolt holes. If not specified, the standard dimension of F is applied.

Roller Guide RA Series

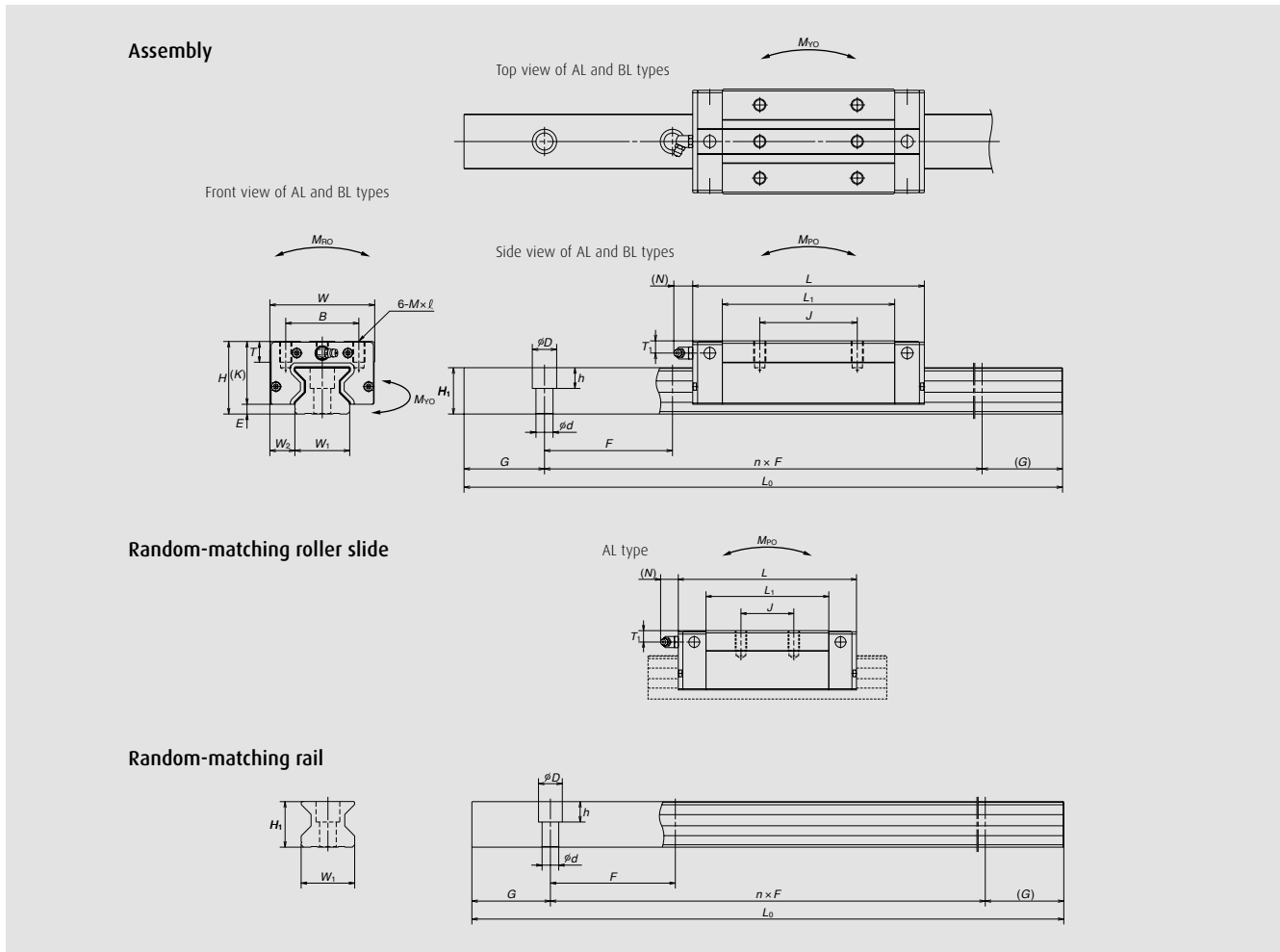

Unit: mm

Rail				Basic load rating								Weight	
Pitch F	Mounting bolt hole d × D × h	G (reference)	Maximum length L _{0max}	3) Dynamic		Static C ₀ (N)	M _{R0}	Static moment (N·m)				Roller slide (kg)	Rail (kg/m)
				[50km] C ₅₀ (N)	[100km] C ₁₀₀ (N)			M _{P0}		M _{Y0}			
				One slide	Two slides	One slide	Two slides						
60 (30)	4.5×7.5×5.3	20	2 000	12 600 16 000	10 300 13 000	27 500 37 000	260 350	210 375	1 320 2 130	210 375	1 320 2 130	0.17 0.25	1.6
30 (60)	7×11×9	20	3 900	36 000 43 500	29 200 35 400	72 700 92 900	970 1 240	760 1 240	4 850 7 200	760 1 240	4 850 7 200	0.45 0.80	
40 (80)	9×14×12	20	3 900	47 800 58 500	38 900 47 600	93 500 121 000	1 670 2 170	1 140 1 950	7 100 11 500	1 140 1 950	7 100 11 500	0.85 1.1	4.9
40 (80)	9×14×12	20	3 900	65 500 82 900	53 300 67 400	129 000 175 000	2 810 3 810	1 800 3 250	11 000 17 800	1 800 3 250	11 000 17 800	1.2 1.7	
52.5 (105)	14×20×17	22.5	3 650	114 000 143 000	92 800 116 000	229 000 305 000	6 180 8 240	4 080 7 150	24 000 39 000	4 080 7 150	24 000 39 000	2.5 3.4	10.9
60 (120)	16×23×20	30	3 600	159 000 207 000	129 000 168 000	330 000 462 000	10 200 14 300	7 060 13 600	41 000 72 000	7 060 13 600	41 000 72 000	4.1 5.7	

2) The random-matching type is available for the models of RA25 to RA65.
 3) The basic load rating comply with the ISO standard. (ISO 14728-1, 14728-2)
 C₅₀: the basic dynamic load rating for 50 km rated fatigue life
 C₁₀₀: the basic dynamic load rating for 100 km rated fatigue life

RA Series dimension table

Flange type (for both tapped and bolt mounting holes)
 RA-EM (High-load type/standard), RA-GM (Super-high-load type/long)

(1) Reference number for preloaded assembly

RA 35 1000 EM C 2 - ※ P6 3

Series name: RA
 Size: 35
 Rail length (mm): 1000
 Roller slide shape code EM, GM: EM
 Material and surface treatment code: C
 C: Special high carbon steel (NSK standard)

Preload code: 2
 Accuracy code: ※
 Design serial number: P6
 Number of roller slides per rail: 3

Preload code: 1: Z1, 3: Z3, Z: ZZ, H: ZH
 Accuracy code: (Without NSK K1): P3, P4, P5, P6, PH
 (With NSK K1): K3, K4, K5, K6, KH

(2) Reference number for random-matching type

Roller slide: RAA 35 EM PH H -F

Random-matching roller slide series code: RAA
 RAA: RA Series random-matching roller slide
 Size: 35
 Roller slide shape code EM, GM: EM

Option code: PH, H, -F
 No code: No surface treatment
 -F: Fluoride low temperature chrome plating
 -C: No surface treatment + Rail cover
 -CF: Fluoride low temperature chrome plating + Rail cover

Preload code: PH, H
 Z: Slight preload, H: Medium preload
 Accuracy code: -F, -CF
 PH, KH: High-precision grade random-matching type

Rail: R1A 35 1000 L C N - ※ PH Z

Random-matching roller slide series code: R1A
 RAA: RA Series random-matching roller slide
 Size: 35
 Rail length (mm): 1000
 Rail shape code L: L
 L: Standard
 Material and surface treatment code: C

Preload code: N
 Accuracy code: ※
 Design serial number: PH
 Added to the reference number: Z
 *Butting rail specification
 N: Non-butting, L: Butting specification

*Please consult with NSK for butting rail specification.

Model No.	Assembly			Roller slide													Width W ₁	Height H ₁
	Height H	E	W ₂	Width W	Length L	Mounting hole				L ₁	K	T	Grease fitting					
						B	J	J ₂	M × pitch × ℓ				Hole size	T ₁	N			
RA15EM RA15GM	24	4	16	47	70 85.4	38	30	26	M5×0.8×8.5 (6.5)	44.8 60.2	20	8	φ3	4	3	15	16.3	
RA20EM RA20GM	30	5	21.5	63	86.5 106.3	53	40	35	M6×1×9.5 (8)	57.5 77.3	25	10	φ3	4	3	20	20.8	
RA25EM RA25GM	36	5	23.5	70	97.5 115.5	57	45	40	M8×1.25×10 (11)	65.5 83.5	31	11	M6×0.75	6	11	23	24	
RA30EM RA30GM	42	6.5	31	90	110.8 135.4	72	52	44	M10×1.5×12 (12.5)	74 98.6	35.5	11	M6×0.75	7	11	28	28	
RA35EM RA35GM	48	6.5	33	100	123.8 152	82	62	52	M10×1.5×13 (7)	83.2 111.4	41.5	12	M6×0.75	8	11	34	31	
RA45EM RA45GM	60	8	37.5	120	154 190	100	80	60	M12×1.75×15 (10.5)	105.4 141.4	52	13	R _c 1/8	10	14	45	38	
RA55EM RA55GM	70	9	43.5	140	184 234	116	95	70	M14×2×18 (13)	128 178	61	15	R _c 1/8	11	14	53	43.5	
RA65EM RA65GM	90	13	53.5	170	228.4 302.5	142	110	82	M16×2×24 (18.5)	155.4 229.5	77	22	R _c 1/8	19	14	63	55	

Notes: 1) Select either one of two F dimensions, the standard or the parenthesized semi-standard dimension, for the pitch of rail fixing bolt holes. If not specified, the standard dimension of F is applied.

Roller Guide RA Series

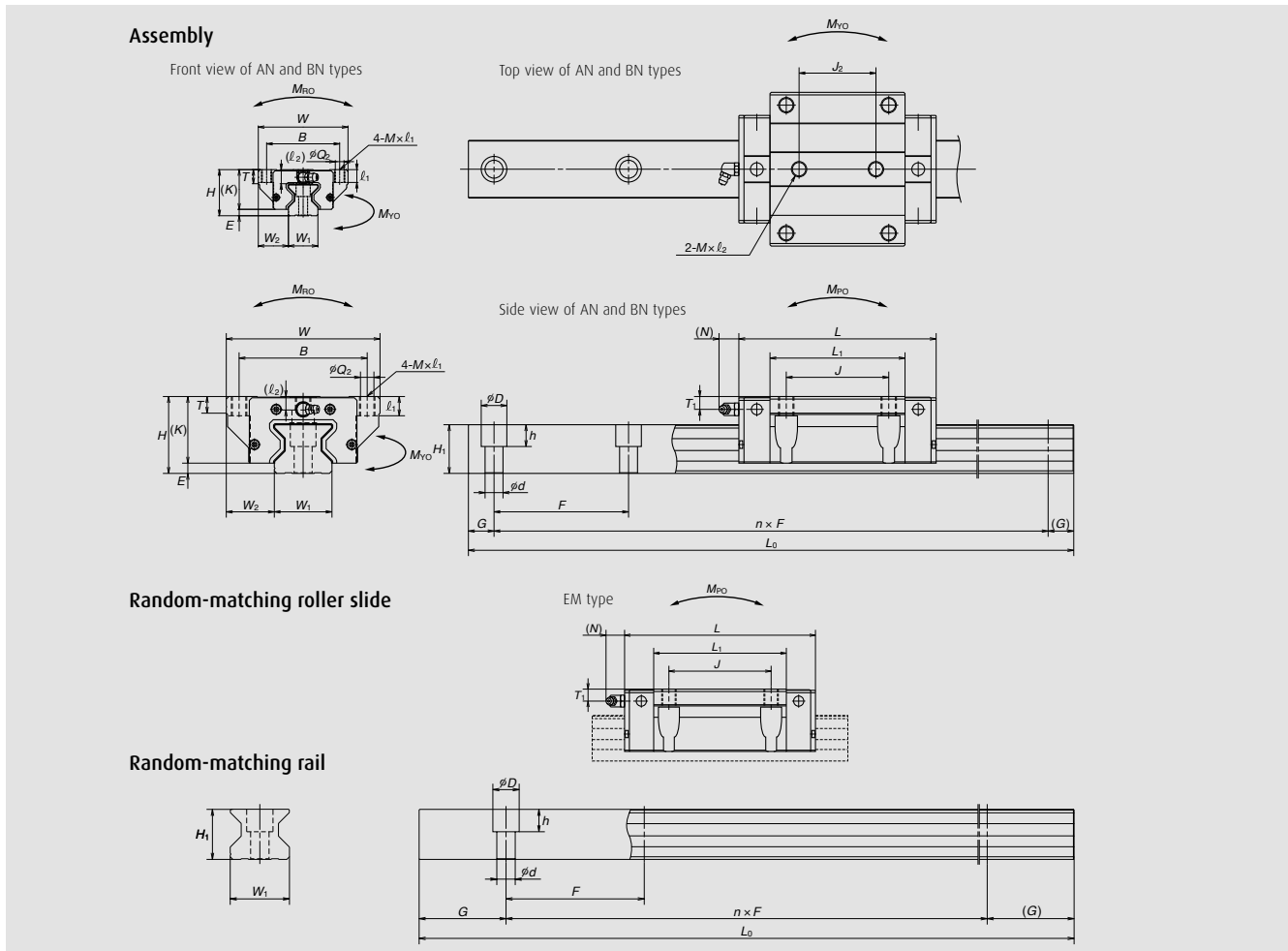

Unit: mm

Rail		G (reference)	Maximum length L_{0max}	Basic load rating								Weight	
Pitch F	Mounting bolt hole $d \times D \times h$			3) Dynamic		Static C_0 (N)	M_{Ro}	Static moment (N·m)				Roller slide (kg)	Rail (kg/m)
				[50km] C_{50} (N)	[100km] C_{100} (N)			M_{p0}		M_{y0}			
						One slide	Two slides	One slide	Two slides				
60 (30)	4.5×7.5×5.3	20	2 000	12 600 16 000	10 300 13 000	27 500 37 000	260 350	210 375	1 320 2 130	210 375	1 320 2 130	0.21 0.28	1.6
60 (30)	6×9.5×8.5	20	3 000	23 600 29 500	19 200 24 000	52 500 70 000	665 890	505 900	3 100 5 000	505 900	3 100 5 000	0.45 0.65	
30 (60)	7×11×9	20	3 900	36 000 43 500	29 200 35 400	72 700 92 900	970 1 240	760 1 240	4 850 7 200	760 1 240	4 850 7 200	0.80 1.1	3.4
40 (80)	9×14×12	20	3 900	47 800 58 500	38 900 47 600	93 500 121 000	1 670 2 170	1 140 1 950	7 100 11 500	1 140 1 950	7 100 11 500	1.3 1.7	
40 (80)	9×14×12	20	3 900	65 500 82 900	53 300 67 400	129 000 175 000	2 810 3 810	1 800 3 250	11 000 17 800	1 800 3 250	11 000 17 800	1.7 2.3	6.8
52.5 (105)	14×20×17	22.5	3 650	114 000 143 000	92 800 116 000	229 000 305 000	6 180 8 240	4 080 7 150	24 000 39 000	4 080 7 150	24 000 39 000	3.2 4.3	
60 (120)	16×23×20	30	3 600	159 000 207 000	129 000 168 000	330 000 462 000	10 200 14 300	7 060 13 600	41 000 72 000	7 060 13 600	41 000 72 000	5.4 7.5	14.6
75 (150)	18×26×22	35	3 600	259 000 355 000	210 000 288 000	504 000 756 000	19 200 28 700	12 700 28 600	78 500 153 000	12 700 28 600	78 500 153 000	12.2 16.5	

2) The random-matching type is available for the models of RA25 to RA65.
 3) The basic load rating comply with the ISO standard. (ISO 14728-1, 14728-2)
 C_{50} : the basic dynamic load rating for 50 km rated fatigue life
 C_{100} : the basic dynamic load rating for 100 km rated fatigue life