

BLOCKWAGEN RA-AL UND RA-BL

Verschiedene Beschichtungsvarianten auf Anfrage.

Standard: hohe Vorspannung.

Details zu den Schienen siehe Seite 70.

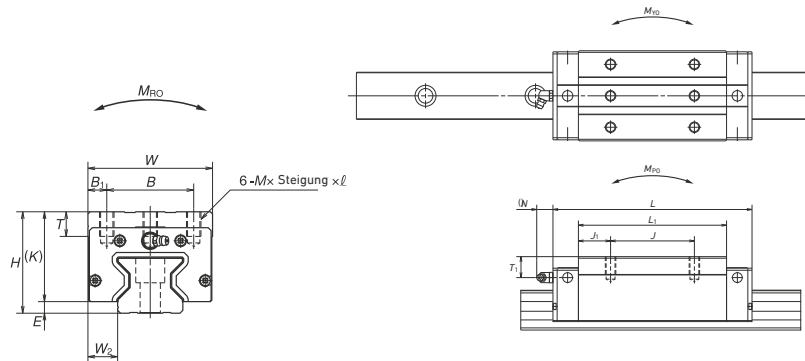

Artikel	H	W	L	B	J	E	W2	MxSteigungxl	B1	L1	J1	K	T	Schmier-anschluss	T1	N	Tragzahlen		Momente			Gewicht Wagen	
																	dyn. (C)	stat. (C ₀)	M _{R0}	M _{P0}	M _{Y0}		
																	[N]		[Nm]			[kg]	
																	[mm]						
RAA25AL	36	48	97,5	35	35	5	12,5	M6x1x8	6,5	65,5	15,25							29200	72700	970	760	760	0,45
RAA25BL			116	50	50					83,5	16,8	31	12	M6x0,75	6	11		35400	92900	1240	1240	1240	0,8
RAA30AL			111	40	40					74	17							38900	93500	1670	1140	1140	0,85
RAA30BL	42	60	135	60	60	6,5	16	M8x1,25x11	10	98,6	19,3	35,5	14	M6x0,75	7	11		47600	121000	2170	1950	1950	1,1
RAA35AL			124	50	50					83,2	16,6							53300	129000	2810	1800	1800	1,2
RAA35BL	48	70	152	72	72	6,5	18	M8x1,25x12	10	111	19,7	41,5	15	M6x0,75	8	11		67400	175000	3810	3250	3250	1,7
RAA45AL			154	60	60					105	22,7							92800	229000	6180	4080	4080	2,5
RAA45BL	60	86	190	80	80	8	20,5	M10x1,5x16	13	141	30,7	52	17	Rc1/8	10	14		116000	305000	8240	7150	7150	3,4
RAA55AL			184	75	75					128	26,5							129000	330000	10200	7060	7060	4,1
RAA55BL	70	100	234	95	95	9	23,5	M12x1,75x18	12,5	178	41,5	61	18	Rc1/8	11	14		168000	462000	14300	13600	13600	5,7

