

• BLOCKWAGEN RA-AN UND RA-BN

Verschiedene Beschichtungsvarianten auf Anfrage.

Standard: hohe Vorspannung.

Details zu den Schienen siehe Seite 70.

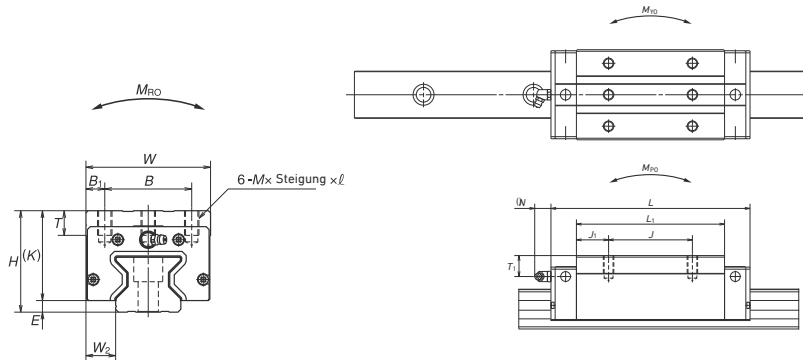

| Artikel | H | W | L | B | J | E | W2 | M×Steigung×l | B1 | L1 | J1 | K | T | Schmier- an- schluss | T1 | N | Tragzahlen | | Momente | | | Gewicht Wagen | |
|----------------|----|-----|-------|----|-----|------|-------------|--------------|-------|-------|-------|----|---------|----------------------------|----|--------|-------------|----------------------------|-----------------|-----------------|-----------------|------------------|--|
| | | | | | | | | | | | | | | | | | dyn. (C) | stat. (C ₀) | M _{RO} | M _{PO} | M _{YO} | | |
| | | | | | | | | | | | | | | | | | [mm] | [N] | [Nm] | [kg] | | | |
| RAA25AN | 40 | 48 | 97,5 | 35 | 35 | 5 | 12,5 | M6×1×9 | 6,5 | 65,5 | 15,25 | 35 | 12 | M6×0,7 | 10 | 11 | 29200 | 72700 | 970 | 760 | 760 | 0,6 | |
| RAA25BN | | | 115,5 | | | | | | | 83,5 | 16,75 | | | | | | 35400 | 92900 | 1240 | 1240 | 1240 | 0,91 | |
| RAA30AN | 45 | 60 | 110,8 | 40 | 6,5 | 16 | M8×1,25×11 | 10 | 74 | 17 | 38,5 | 14 | M6×0,75 | 10 | 10 | 38900 | 93500 | 1670 | 1140 | 1140 | 1 | | |
| RAA30BN | | | 135,4 | | | | | | 98,6 | 19,3 | | | | | | 47600 | 121000 | 2170 | 1950 | 1950 | 1,3 | | |
| RAA35AN | 55 | 70 | 123,8 | 50 | 6,5 | 18 | M8×1,25×12 | 10 | 83,2 | 16,6 | 48,5 | 15 | M6×0,75 | 15 | 11 | 53300 | 129000 | 2810 | 1800 | 1800 | 1,6 | | |
| RAA35BN | | | 152 | | | | | | 111,4 | 19,7 | | | | | | 67400 | 175000 | 3810 | 3250 | 3250 | 2,1 | | |
| RAA45AN | 70 | 86 | 154 | 60 | 8 | 20,5 | M10×1,5×17 | 13 | 105,4 | 22,7 | 62 | 17 | Rc1/8 | 20 | 14 | 92800 | 229000 | 6180 | 4080 | 4080 | 3 | | |
| RAA45BN | | | 190 | | | | | | 141,4 | 30,7 | | | | | | 116000 | 305000 | 8240 | 7150 | 7150 | 4,1 | | |
| RAA55AN | 80 | 100 | 184 | 75 | 9 | 23,5 | M12×1,75×18 | 13 | 128 | 26,5 | 71 | 18 | Rc1/8 | 21 | 14 | 129000 | 330000 | 10200 | 7060 | 7060 | 4,9 | | |
| RAA55BN | | | 234 | | | | | | 178 | 41,5 | | | | | | 168000 | 462000 | 14300 | 13600 | 13600 | 6,7 | | |
| RAA65AN | 90 | 126 | 228,4 | 76 | 13 | 31,5 | M16×2×20 | 25 | 155,4 | 42,7 | 77 | 22 | Rc1/8 | 19 | 14 | 210000 | 504000 | 19200 | 12700 | 12700 | 9,3 | | |
| RAA65BN | | | 302,5 | | | | | | 229,5 | 54,75 | | | | | | 288000 | 756000 | 28700 | 28600 | 28600 | 12,2 | | |

