

# LT80 SERIES

Compact linear units with internal wheel- or rail guide

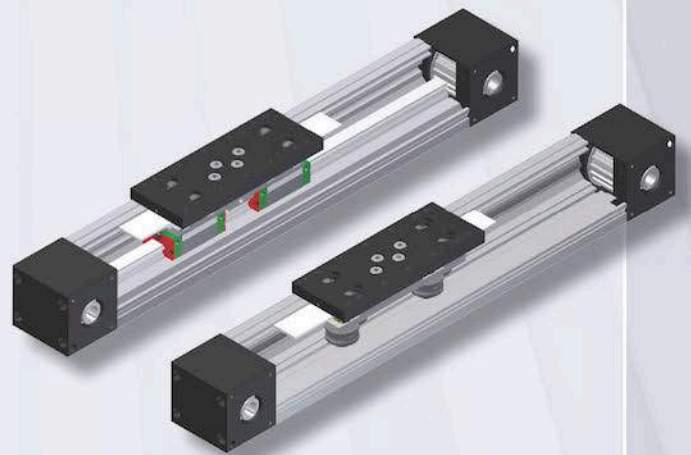

- Internal guide linear units, width of the profile 80 mm
- Hardened guide wheels on hardened shafts -10-, highly resistant to pollution
- Internal recirculating ball rail guide size -20- for heavy loads
- Magnetic switches in T-slot for position detection
- Toothed belt type 32 AT10
- Advanced internal lubrication system

**TECHNICAL DATA**

**LT80-TR-G10**

**LT80-TR-S20D**

Maximum stroke length	mm	5.750	5.750
Maximum speed	mm/s	5.000	3.000
Maximum acceleration	m/s <sup>2</sup>	50	30
No load torque	Nm	0,8	1,1
Repeatability	mm	± 0,1	± 0,1
Movement per revolution	mm	200	200

# LT80 SERIES

## TECHNICAL DATA

LOAD CAPACITY		LT80-TR-G10	LT80-TR-S20D
Mx	Nm	86	720
My	Nm	126	960
Mz	Nm	50	220
Fx	N	4.400	4.400
Fy	N	1.400	7.400
Fz	N	1.400	7.400

Note: G10 wheel guide also available in stainless steel.

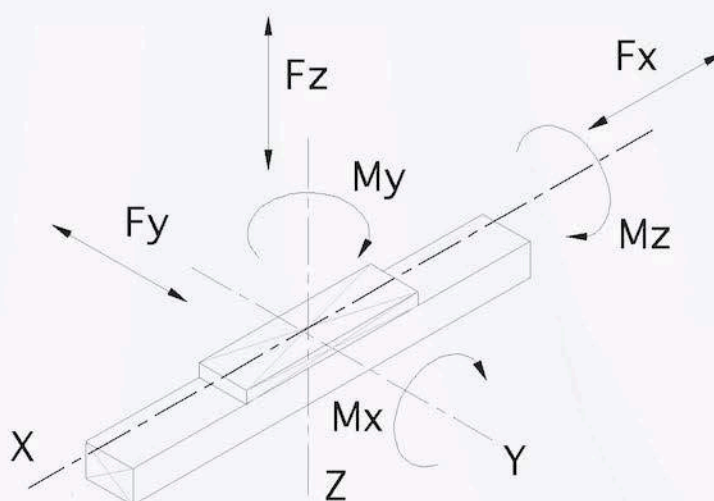

## WEIGHTS (KG)

LT80-TR-S20D	
Unit weight 0 mm stroke	7,96
Weight per 100 mm stroke	0,72
Mass of carriage	2,25

# LT80 SERIES

## DIMENSIONS

### DIMENSIONS LT80-TR-G10

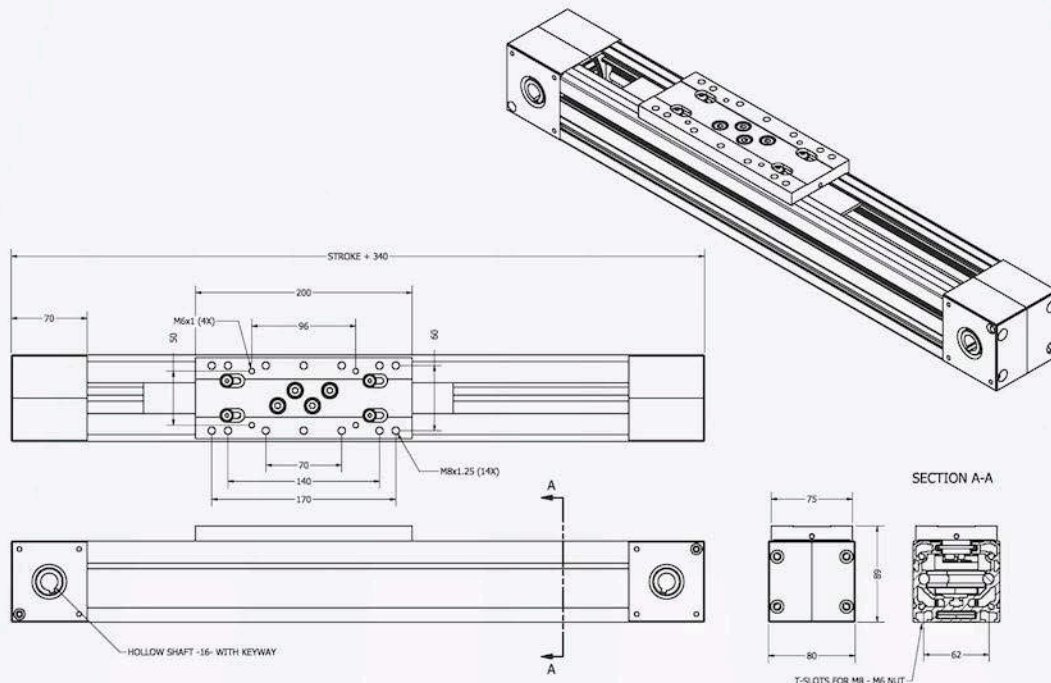

### DIMENSIONS LT80-TR-S20D

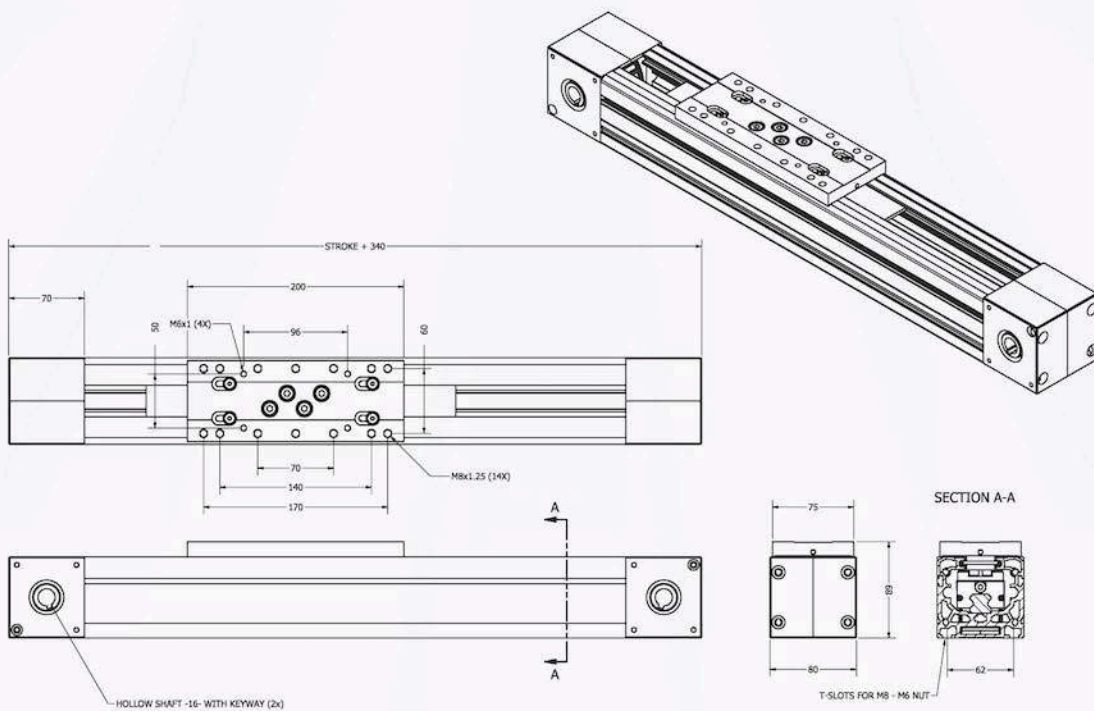



# LT80 SERIES

## DIMENSIONS

### DIMENSIONS FOR MOUNTING

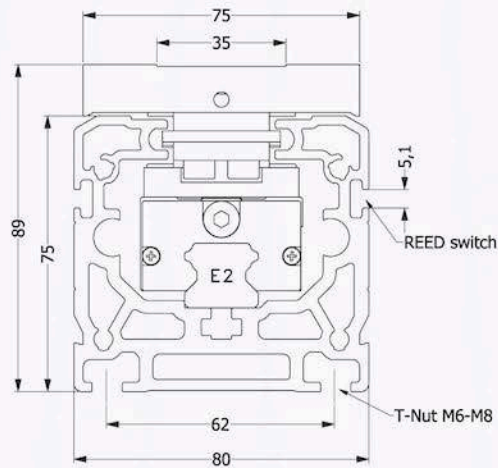

### CLAMPING DIMENSIONS

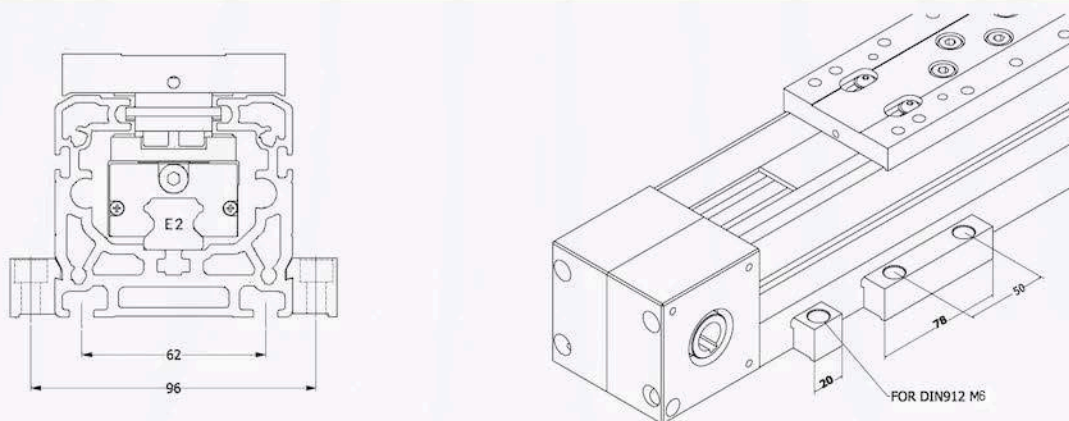

### DIMENSIONS FOR MOTOR ATTACHEMENT

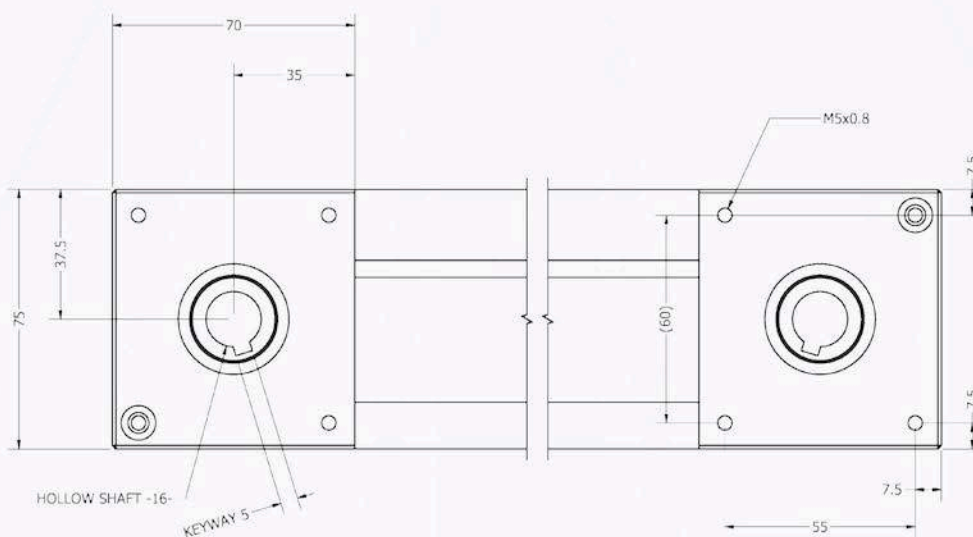

# LT80-TR-S20D

## MOTOR ACCESSORIES

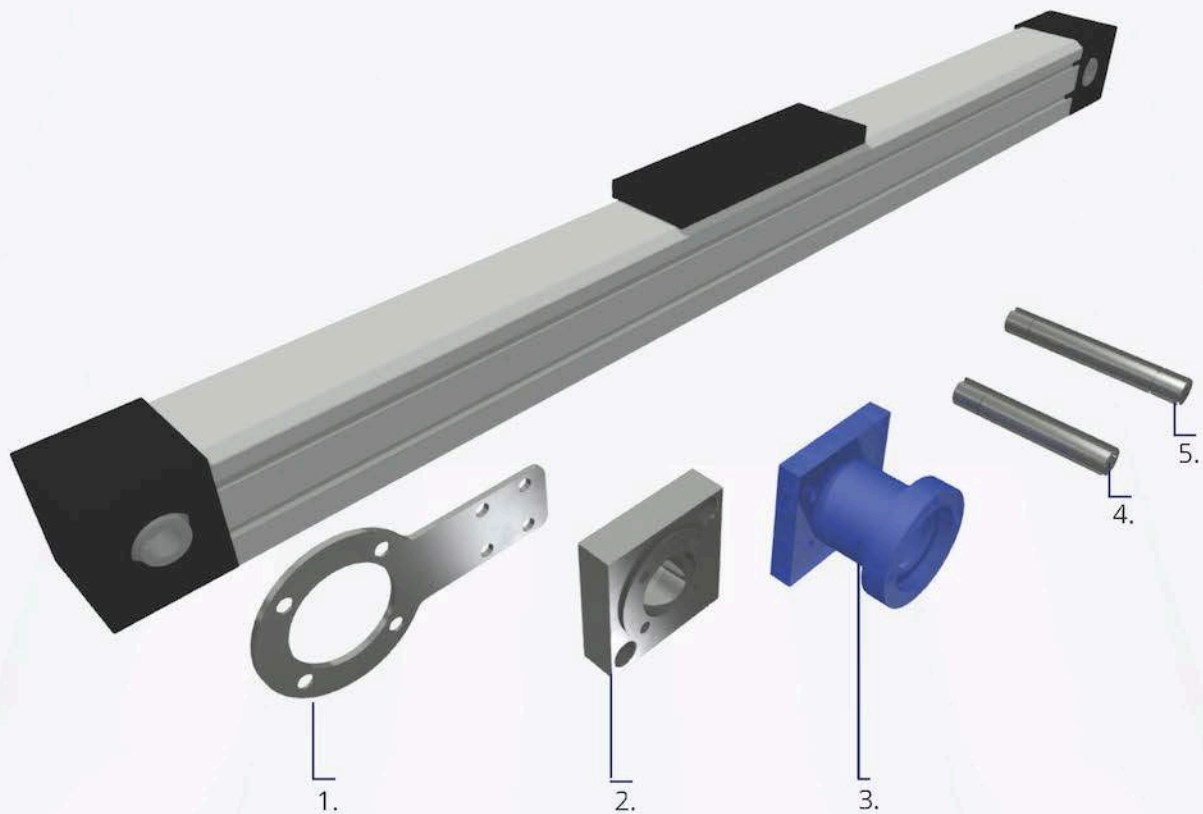

1	8070-RA-M-XXX	Motor adapter armtype
2	8070-F-XXX	Motor Flange
3	8070-FL-XXX	Motor adapter
4	8070-SS-16-GS19	Single shaft $\varnothing 16$
5	8070-DS-16-GS19	Double shaft $\varnothing 16$

# LT80-TR-S20D

## ACCESSORIES

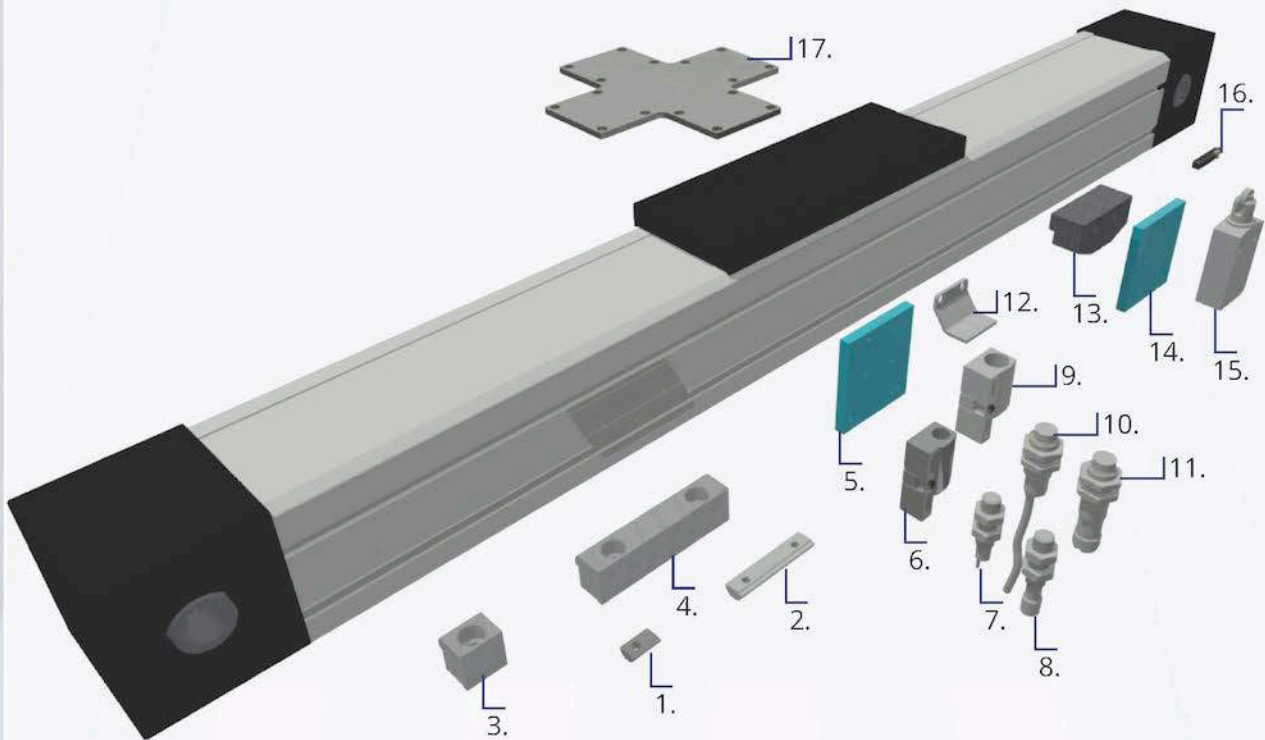

1	111-036	Single Nut M5
1	111-028	Single Nut M6
1	111-029	Single Nut M8
2	172-710	Double Nut M8 L=26
2	172-711	Double Nut M8 L=66
2	172-713	Double Nut M6 L=40
2	172-714	Double Nut M8 L=40
3	80121	Clamping plate single
4	80122	Clamping plate double
5	8070-SH-XS	Bracket for Telem. Bracket
6	XSZB108	Bracket for M8 sensor
7	XS05B1PAL2	M8 inductive sensor-cable
8	XS508B1PAM8	M8 inductive sensor-M8
9	XSZB112	Bracket for M12 sensor
10	XS212b4pal	M12 inductive sensor-cable
11	XS212b4pbm	M12 inductive sensor-M8
12	8070-DB4-IN	Sensor bracket
13	8070-SD-ME	Switch bracket
14	8070-XCMD-B	Bracket for switch
15	XCMD2102L	Switch with roll
16	ASV1-C525	Reed switch
17	8070-XP-D	X-Cross-bracket

Almotion B.V. Nijverheidsweg 14 | 6662 NG Elst (Gld) | The Netherlands t +31 (0)85 0491 777 e info@almotion.nl

www.almotion.nl | www.linearmotion.nl | www.lineairegeleiding.nl

All drawings can be downloaded from www.linearmotion.nl