

LTZ80 SERIES

Compact linear units with
internal rail guide

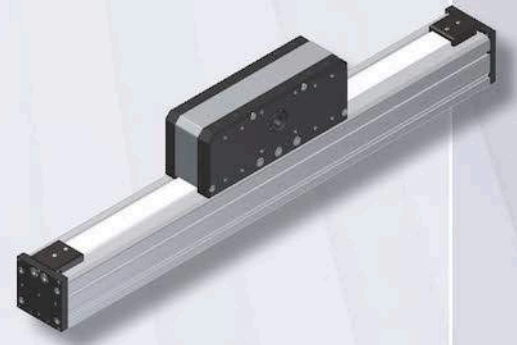

- Internal guide linear units, width of the profile 80 mm
- Internal recirculating ball rail guide size - 20 - for heavy loads
- Toothed belt type 32 AT10
- Omega belt construction

TECHNICAL DATA

LTZ80-TR-S20D

Maximum stroke length	mm	5.700
Maximum speed	mm/s	3.000
Maximum acceleration	m/s ²	30
No load torque	Nm	0,9
Repeatability	mm	± 0,1
Movement per revolution	mm	200

LTZ80 SERIES

TECHNICAL DATA

LOAD CAPACITY

LTZ80-TR-S20D

Mx	Nm	810
My	Nm	1.040
Mz	Nm	220
Fx	N	4.400
Fy	N	7.400
Fz	N	7.400

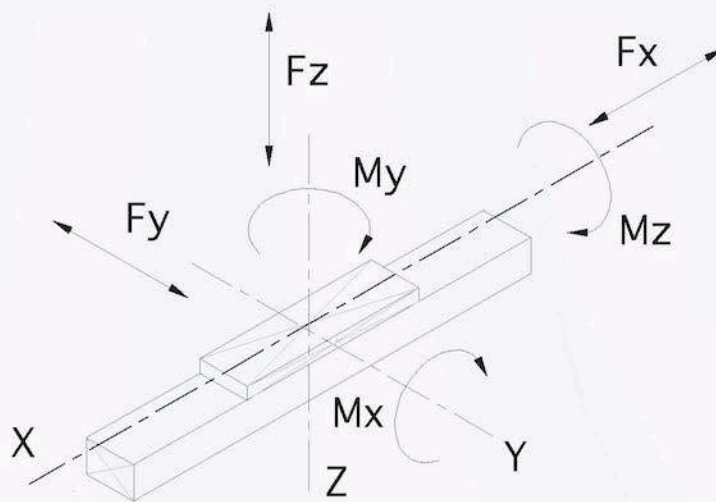

WEIGHTS (KG)

LTZ80-TR-S20D

Unit weight 0 mm stroke	9,41
Weight per 100 mm stroke	0,72

LTZ80 SERIES

DIMENSIONS LTZ80-TR-S20D

