

ALI3-P Model CE

- Permanent magnet motor CE
- Worm gearbox
- Acme lead screw or ballscrew (VRS)
- Chrome plated steel push rod
- Permanent grease lubrication
- IP65, tested according to rule CEI EN 60529
- Working temperature range -10°C +60°C
- Intermittent duty S3 30% (5 min) a +30°C*
- Limit switches, potentiometer and encoder on request

(*) For any special duty please contact our technical dept.

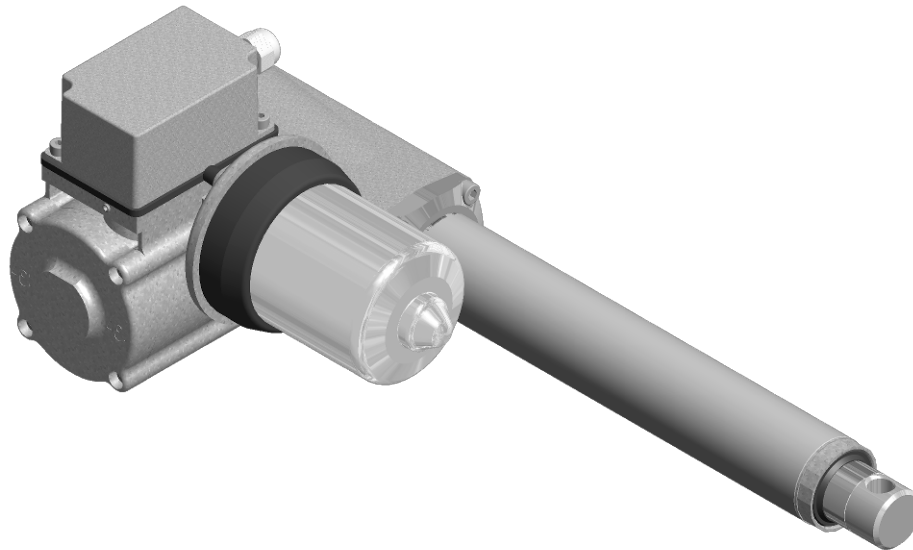

ALI3-P (Vdc)						
Fmax (N)	Speed (mm/s)	Version	Motor size	Motor power (KW)	Motor speed (rpm)	Max Current for Fmax(A) 24Vdc
3600	35	M01	61.5	-	5000	14
3600	25	M02	61.5	-	5000	10
6000	12	M03	61.5	-	5000	11
6000	9	M04	61.5	-	5000	8,8
6000	5	M05	61.5	-	5000	7,2

**

* With strokes longer than 350mm, check STROKE SETUP section.

** For 12 Vdc power supply currents are doubled and loads are 20% lower.

BEFORE OPERATING ACTUATOR MAKE SURE YOU READ AND UNDERSTOOD BASIC OPERATIONAL INSTRUCTIONS SHOWN ON USERMANUALS, AVAILABLE FROM WEBSITE.

THIS DOCUMENT DISPLAYS MOST TYPICAL STANDARD FEATURES AND SETUPS: CONTACT OUR OFFICES FOR MORE.

ACTUATOR SHALL NOT COME TO **MECHANICAL STROKE-END**, TO **AVOID FAILURES**.

CONSIDER MECVEL's LIMITSWITCHES (MODEL ALI3-P-F or ALI3-P-FCM) OR PUT THEM ON MACHINE/FRAME.



MecVel reserves the right to change products information and/or features without notice; all data contained in this catalogue are purely indicative and not binding for the company.

ALI3-P Version without limitswitches

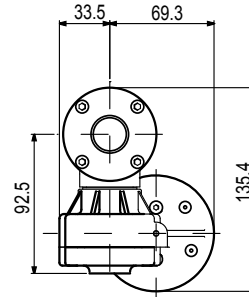
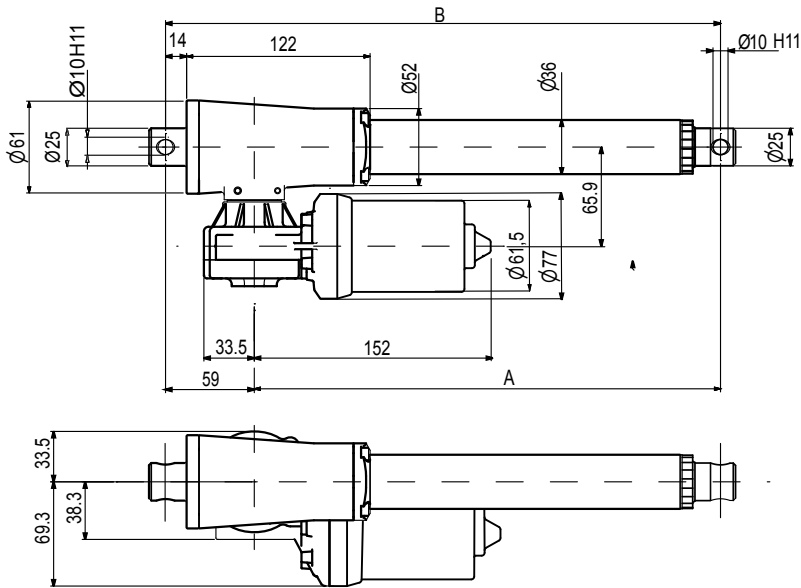

DIMENSION	Stroke < to 320 mm.	Stroke > to 320 mm.
A	110 + stroke	121 + stroke
B	169 + stroke	180 + stroke

ALI3-P-F Version with limitswitches

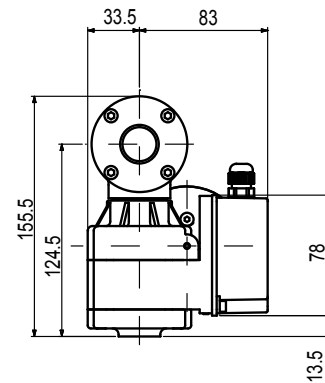
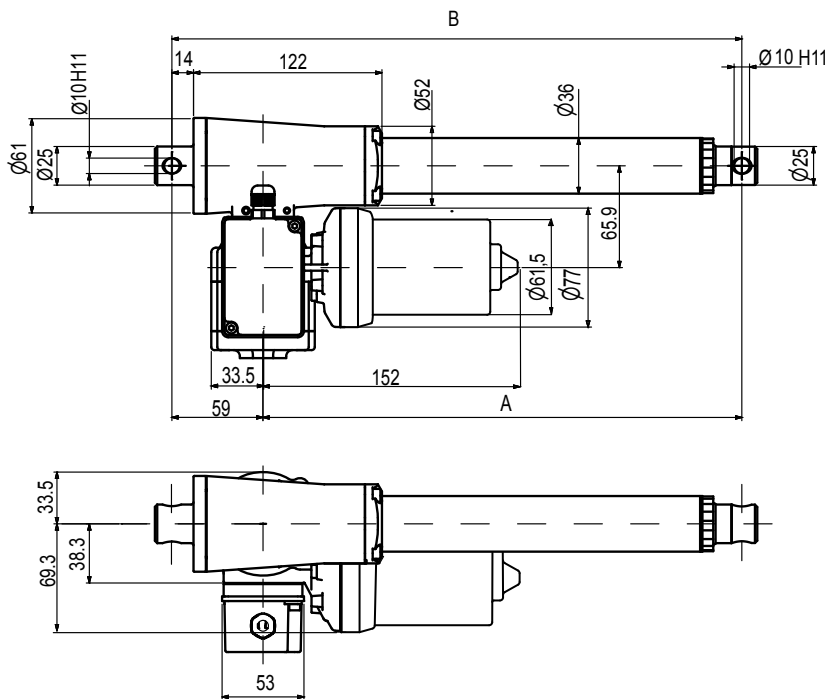

DIMENSION	Stroke < to 320 mm.	Stroke > to 320 mm.
A	110 + stroke	121 + stroke
B	169 + stroke	180 + stroke

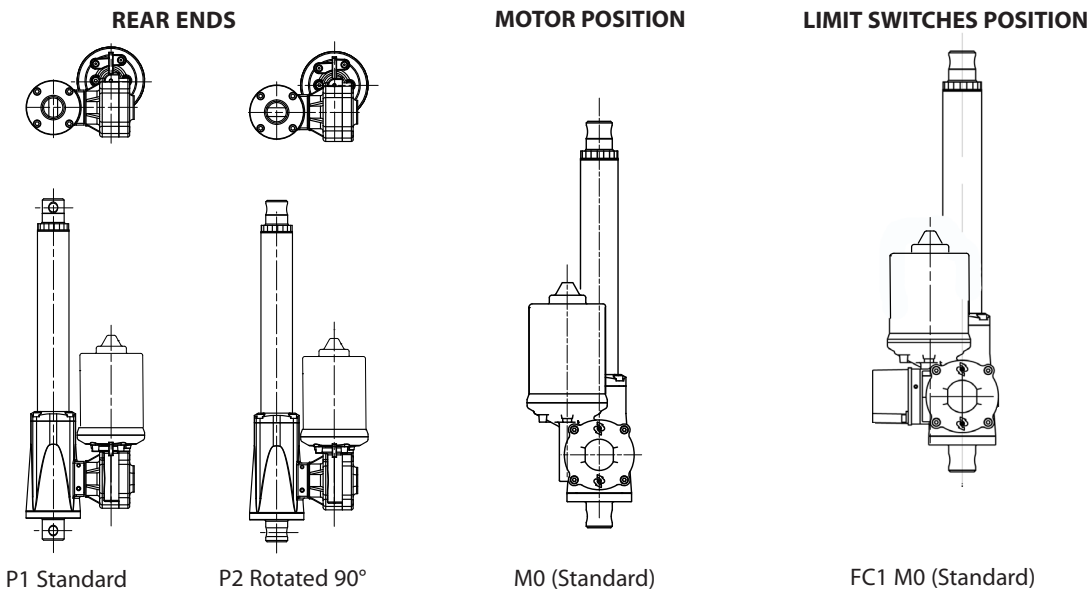

STROKE SETUP: Useful tips for handling stroke and avoid run-on-block collision.

When stroke is more than 350 mm, add 50 mm extra-stroke as guidance, and put corresponding value in ordering-key.

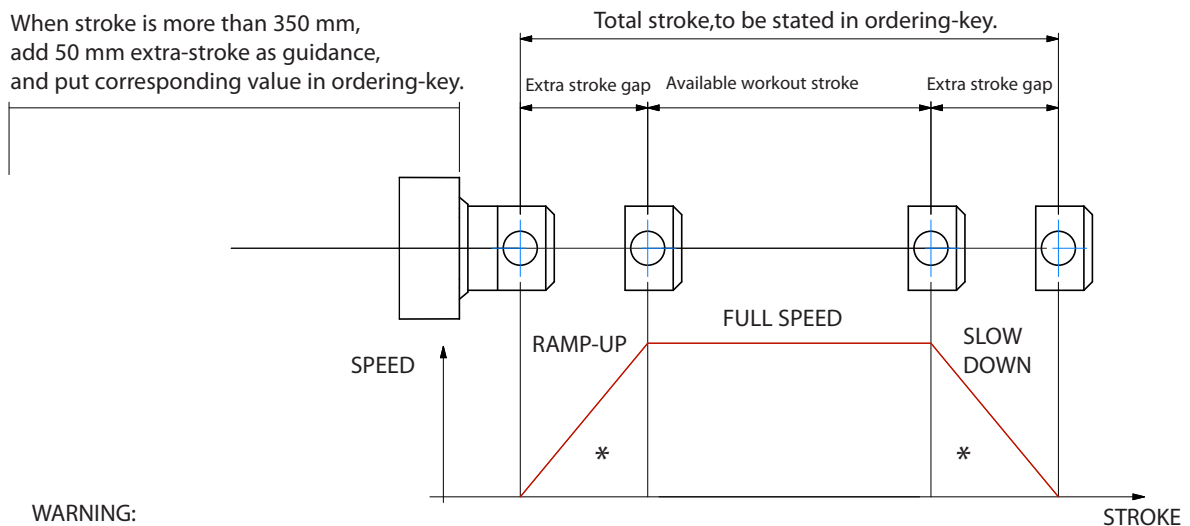

WARNING:
 SPEED-TIMING ALONG STROKELENGTH:
 ramps are extremely important with high speed!!! Inverter or PWM drive recommended!
 * The more speed raises the more extra stroke has to raise too.

BUCKLING: With strokes longer than 500mm, BUCKLING can be a risk: please check mounting with our offices and/or see usermanuals.

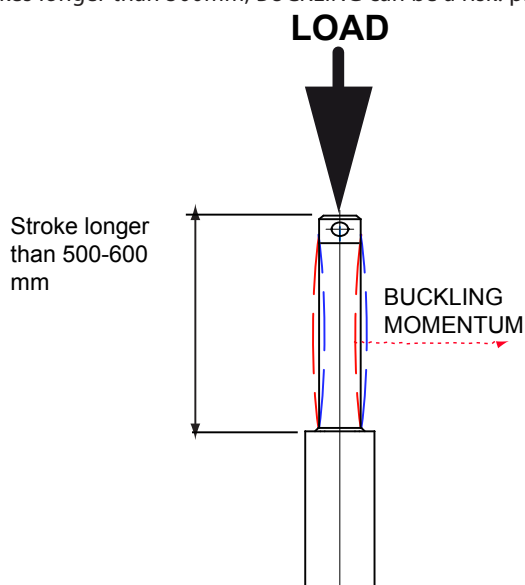

IMPORTANT:
 Long strokes, even if load is low, can generate significant buckling momentums, as sketch slows.
 This happens when actuator is in its all-opened position: that's the reason why we recommend 100 mm extra-stroke.
 Pushtube will have this 100 mm-portion always inside the overtube, improving guidance against buckling.
 For more information on this, contact our office.

ORDERING KEY

ALI3-P-F / 0250 / M01 / CC-24-61,5-5000- / M1 / 1 / E01 / 2FC1 / POT01A / FC1 / P1 / A1

MODEL: _____
 ALI3-P / ALI3-P-F
 ALI3-P-FCM

STROKE: _____
 es. 250 mm = 0250

VERSION: (pag.33) _____
 M01 / M02 / M03 / M04 / M05/
 (version D.C.)
 M00 = Not standard speed

MOTOR: (Page ACCESSORIES) _____
 12 = 12 Vdc
 24 = 24 Vdc

MOTOR POSITION: _____
 M0 None: Leave blank

E-BOX POSITION: _____
 1

No Motor or DC Motor: Leave blank

ENCODER: (Page ACCESSORIES) _____
 None: Leave blank

LIMIT SWITCHES: (Page ACCESSORIES) _____
 None: Leave blank

POTENTIOMETER: _____
 POT01A (1Kohm) POT10A (10Kohm) None: / Leave blank

LIMIT SWITCHES POSITION: _____
 FC1 None: Leave blank

REAR END: _____
 P1 = Eyelet (standard) P2 = Eyelet (90°)

FRONT END: _____
 A1 = Eyelet (Std pag.34) A4 = Rod end
 A3 = Yoke + Clip A7 = M10 male

NOTE: COMPLETE THE ORDERING KEY ADDING THE OPTIONS YOU CAN FIND IN THE "ACCESSORIES AND OPTIONS" SECTION

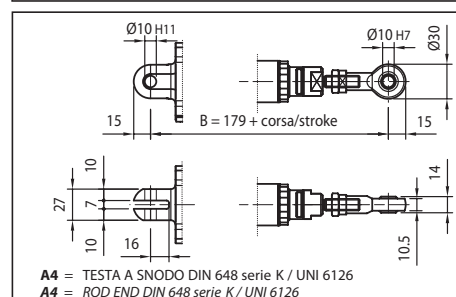
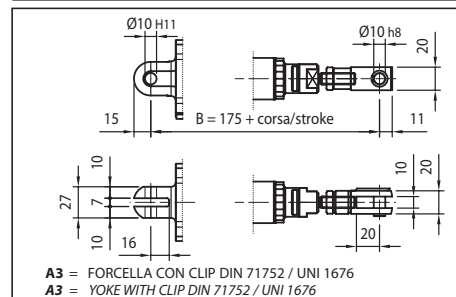
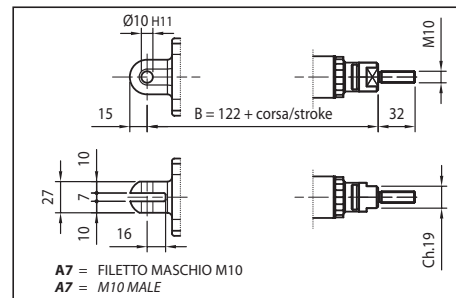
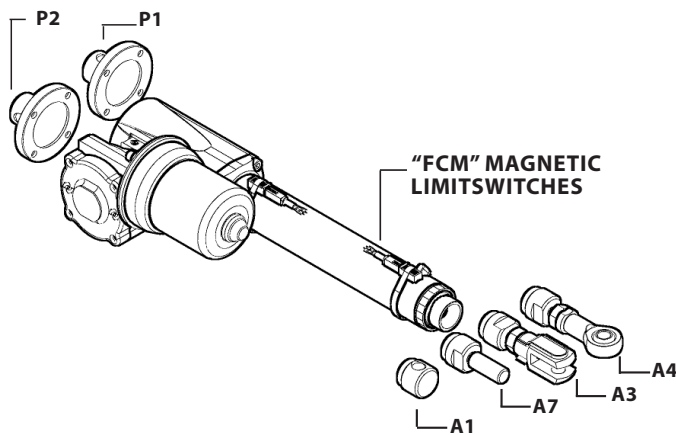

Note: "B" dimension changes according to model
 ALI3-P = see pictures
 ALI3-P stroke > 320 mm = + 10 mm (for all versions)
 ALI3-P-FCM = + 36 mm
 with safety nut "G" = + 30 mm
 Bellow + 20mm (no for versions FCM)