

ALI3 Model C€

- Permanent magnet motor CE
 - Three phase or single phase motor CE
 - Worm gearbox
 - Acme lead screw or ballscrew (VRS)
 - Chrome plated steel push rod
 - Life long grease lubricated
 - IP65, tested according to rule CEI EN 60529
 - NB: Only for brake motors Standard IP54, IP65 on request
 - Working temperature range -10°C +60°C
 - Intermittent duty S3 30% (5 min) a +30°C*
 - Limit switches, potentiometer and encoder on request
- (*) For any special duty please contact our technical dept.

ALI3 (Vac 3-phase)					
Fmax (N)	Speed (mm/s)	Version	Motor size	Motor power (KW)	Motor speed (rpm)
2600	20	M01	IEC50	0.09	2800
2800	14	M02	IEC50	0.09	2800
4800	7	M03	IEC50	0.09	2800
5000	5	M04	IEC50	0.09	2800
5000	2.5	M05	IEC50	0.06	2800

ALI3 (Vdc)						
Fmax (N)	Speed (mm/s)	Version	Motor size	Motor power (KW)	Motor speed (rpm)	Max Current for Fmax(A) 24Vdc
3600	35	M01	61.5	-	5000	13
3600	25	M02	61.5	-	5000	9
6000	12	M03	61.5	-	5000	10
6000	9	M04	61.5	-	5000	7,6
6000	5	M05	61.5	-	5000	5,8

ALI3 VRS (ballscrew) (Vac 3-phase)					
Fmax (N)	Speed (mm/s)	Version	Motor size	Motor power (KW)	Motor speed (rpm)
5000	9	M01	IEC50	0.09	2800
5000	3,5	M02	IEC50	0.09	2800

With single-phase motors type M (see motor choice guideline in paragraph ACCESSORIES) performances are 20% lower than the three-phase motor.

When stroke is longer than 350mm, check STROKE SETUP section; BRAKEMOTOR IS RECOMMENDED

** For 12 Vdc power supply currents are doubled and loads are 20% lower.

BEFORE OPERATING ACTUATOR MAKE SURE YOU READ AND UNDERSTOOD BASIC OPERATIONAL INSTRUCTIONS SHOWN ON USERMANUALS, AVAILABLE FROM WEBSITE.

THIS DOCUMENT DISPLAYS MOST TYPICAL STANDARD FEATURES AND SETUPS: CONTACT OUR OFFICES FOR MORE.

ACTUATOR SHALL NOT COME TO **MECHANICAL STROKE-END**, TO AVOID **FAILURES**.

CONSIDER MECVEL's LIMITSWITCHES (MODEL ALI3-F or ALI3-FCM) OR PUT THEM ON MACHINE/FRAME.



MecVel reserves the right to change products information and/or features without notice; all data contained in this catalogue are purely indicative and not binding for the company.

AL13 Version without limitswitches

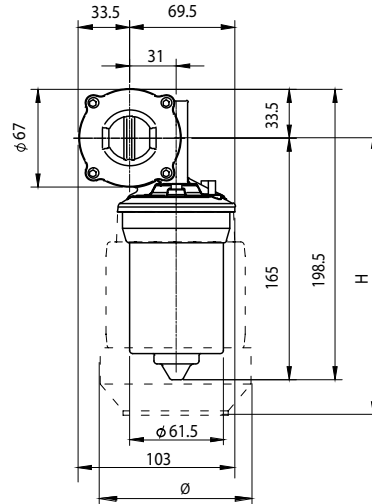
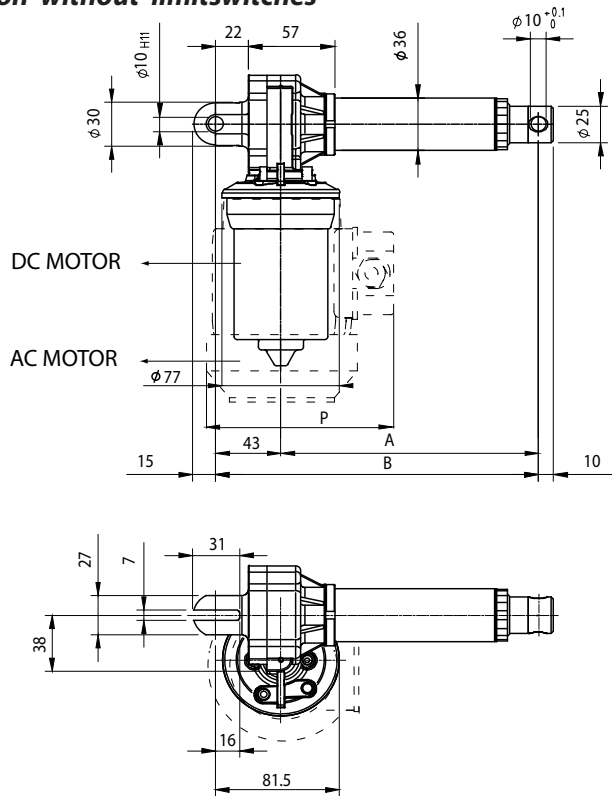

DIM.	Stroke < to 320 mm.	Stroke > to 320 mm.
A	69 + stroke	79 + stroke
B	112 + stroke	122 + stroke

A.C MOTORS DIMENSIONS				
SIZE	TYPE	H	ϕ	P
50	Standard	188	110	105
	Brake Motors	226		
56	Standard	216	110	108
	Brake Motors	260		

With safety nut "G" = + 30 mm
 AL13-VRS = + 40 mm (safety nut unavailable)
 Bellows + 20mm (for FCM limitswitches contact our Offices)

AL13-F Version with limitswitches

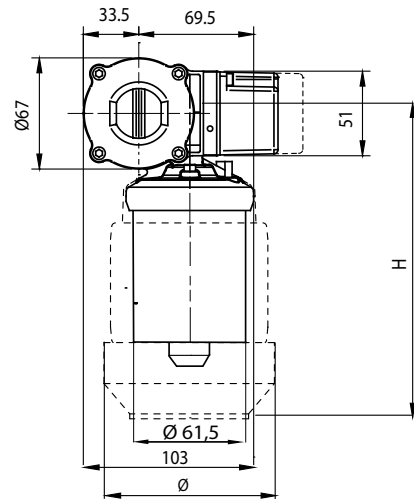
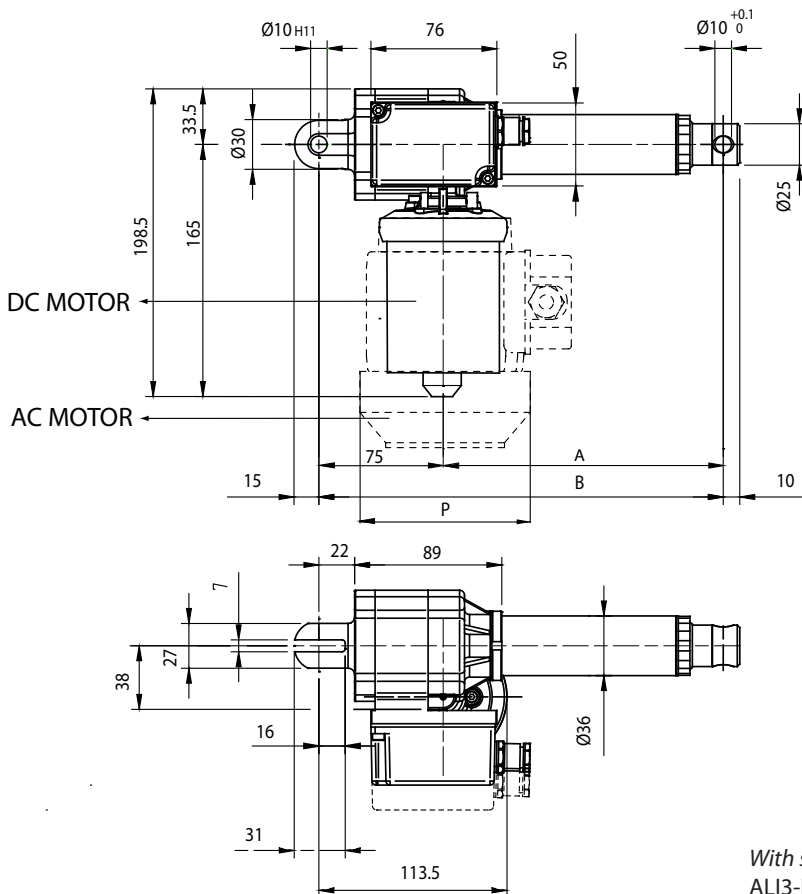

DIM.	Stroke < to 320 mm.	Stroke > to 320 mm.
A	69 + stroke	79 + stroke
B	144 + stroke	154 + stroke

A.C MOTORS DIMENSIONS				
SIZE	TYPE	H	ϕ	P
50	Standard	188	110	105
	Brake Motors	226		
56	Standard	216	110	108
	Brake Motors	260		

With safety nut "G" = + 30 mm
 AL13-F-VRS = + 40 mm (safety nut unavailable)
 Bellows + 20mm (for FCM limitswitches contact our Offices)

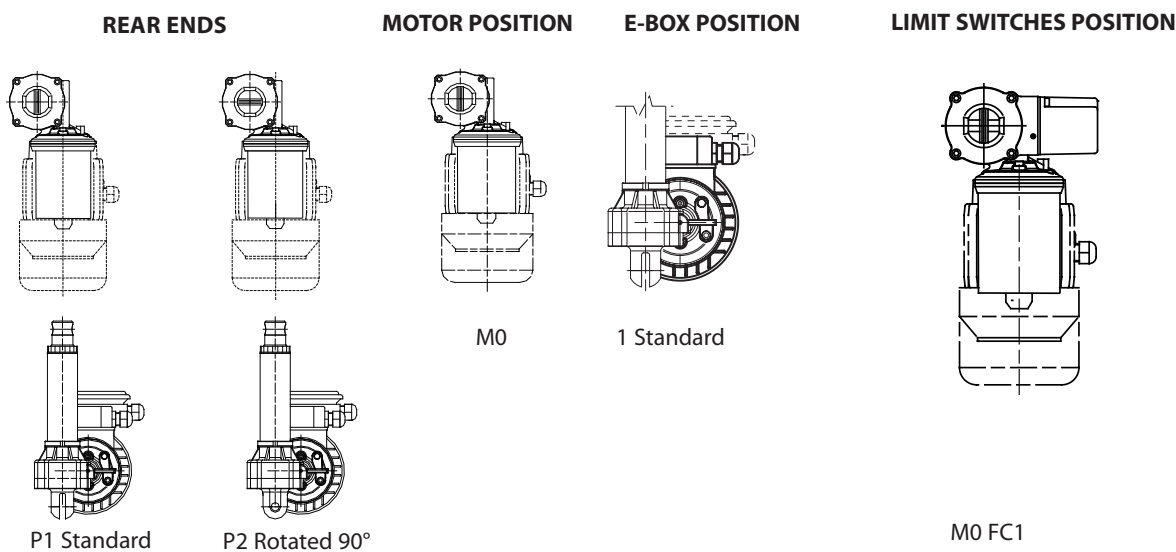

STROKE SETUP: Useful tips for handling stroke and avoid run-on-block collision.

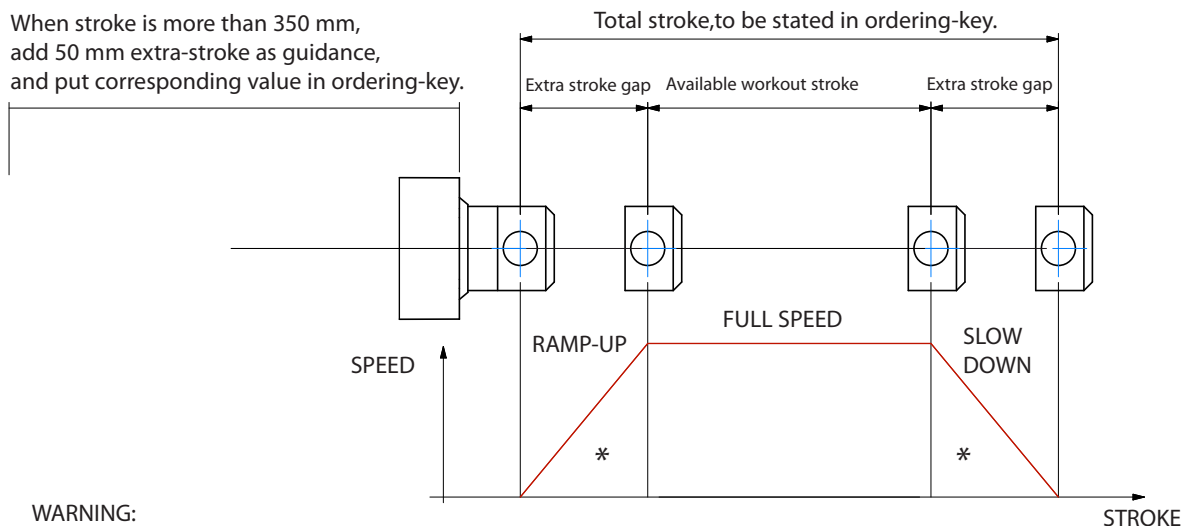

BUCKLING: With strokes longer than 500mm, BUCKLING can be a risk: please check mounting with our offices and/or see usermanuals.

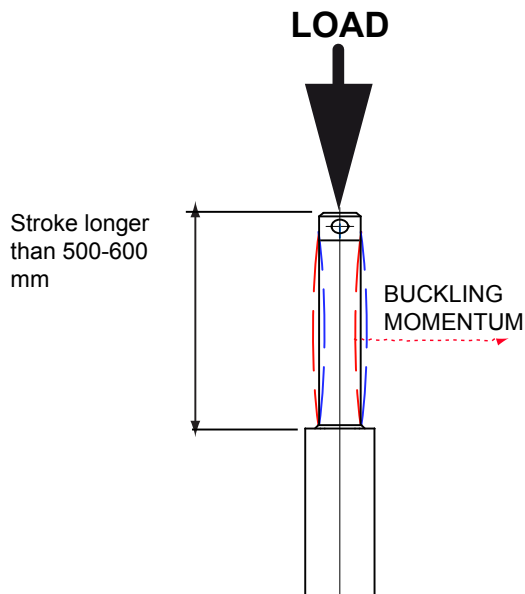

IMPORTANT:
 Long strokes, even if load is low, can generate significant buckling momentums, as sketch slows.
 This happens when actuator is in its all-opened position: that's the reason why we recommend 100 mm extra-stroke.
 Pushtube will have this 100 mm-portion always inside the overtube, improving guidance against buckling.
 For more information on this, contact our office.

ALI3 / 0250 / M01 / CA-400/50-T-56-4-0,09 / AB / M1 / 1 / E01 / 2FC1 / POT01A / FC1 / P1 / A1

MODEL: _____
 ALI3 / ALI3-F / ALI3-VRS / ALI3-F-VRS / ALI3-FCM

STROKE: _____
 es. 250 mm = 0250

VERSION: (Pag. 29) _____
 M01 / M02 / M03 / M04 / M05 (version D.C.)
 M01 / M02 / M03 / M04 / M05 (version A.C.)
 M00 = Not standard speed

MOTOR: (Pag. ACCESSORIES) _____
 Advise only if with motor:
A.C.: version, voltage, type, size, n°pole, power
D.C.: version, voltage, size, Rpm

AC MOTOR OPTIONS: (Pag. ACCESSORIES) _____
 Protection Degree: IP65, for selfbrake motor IP54 standard
 Brake type: for brakemotors only: ES. FECA
 Options: Advise if needed (ES. AB 2'shaft)

MOTOR POSITION: _____
M0 None: Leave blank

E-BOX POSITION: _____
1
 No Motor or DC Motor: Leave blank

ENCODER: (Pag. ACCESSORIES) _____
 None: Leave blank

LIMIT SWITCHES: (Pag. ACCESSORIES) _____
 None: Leave blank

POTENTIOMETER: (Pag. ACCESORIES) _____
POT01A (1Kohm) **POT10A** (10Kohm) None: Leave blank

LIMIT SWITCHES POSITION: _____
FC1 None: Leave blank

REAR END: _____
P1 = Eyelet (standard) **P2** = Eyelet (90°)

FRONT END: _____
A1 = Eyelet (Std pag.30) **A4** = Rod end
A3 = Yoke + Clip **A7** = M10 male

NOTE: COMPLETE THE ORDERING KEY ADDING THE OPTIONS YOU CAN FIND IN THE "ACCESSORIES AND OPTIONS" SECTION

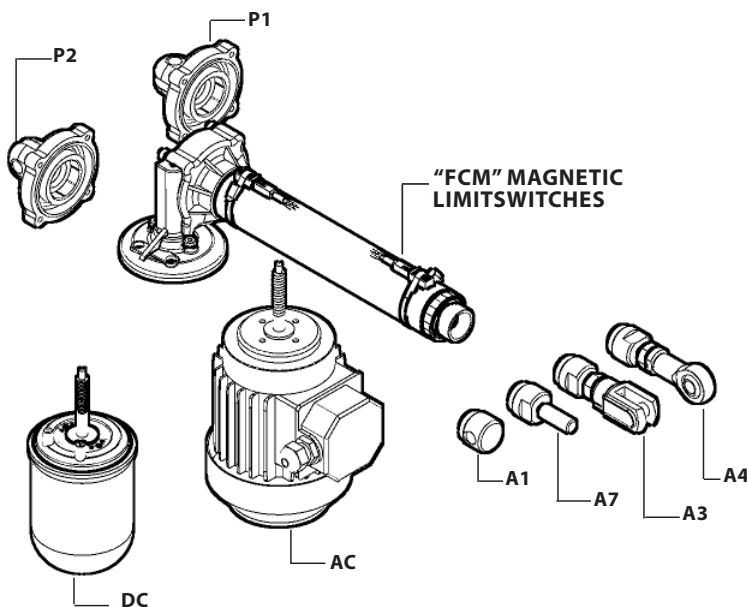

Note: "B" dimension changes according to model

- | | |
|----------------------------------|-------------------------------|
| ALI3 = See pictures | With safety nut "G" = + 30 mm |
| ALI3 stroke > 320 mm = + 10 mm | ALI3-VRS = + 40 mm |
| ALI3-FCM = + 34 mm | ALI3-F-VRS = + 63 mm |
| ALI3-FCM stroke > 320 mm = +44 | Bellows + 20mm |
| ALI3-F = + 23 mm | |
| ALI3-F stroke > 320 mm = + 33 mm | |

