

**ALMOTION**

**Air cylinders**

# Series C76

ø32, ø40



**Standard Type, Non-rotating Type, Direct Mounting Type**

Quick Reference  
Guide

C55

C85

**C76**

CP95

C95

-X  
(Made to Order)

D-  
(Auto Switch)

Model Selection  
Procedures

# C76 Series: Ø32, Ø40

### EASY- ACCURATE MOUNTING

Simple space saving design with high dimensional accuracy makes these cylinders very easy to use.

Large spanner flats on the rod and head covers greatly simplify their installation and positioning.

### HIGH SPEED ACTUATION

Low friction and the standard elastomer cushion rings allow piston speeds up to 1500mm/sec. Either rubber or air cushion are available.

### REPLACEABLE ROD PACKING

Rod packing can be quickly replaced, greatly extending the cylinder life. (C85 Ø20, 25).

### STRONG, CORROSION-PROOF BARREL

The risk of breakage or deformation due to external impacts is reduced by the use of harder, heavy walled stainless steel tube.

### MINIMIZED SIDE CLEARANCE

The close tolerance of the piston rod in the front end bush allows greater side loading.

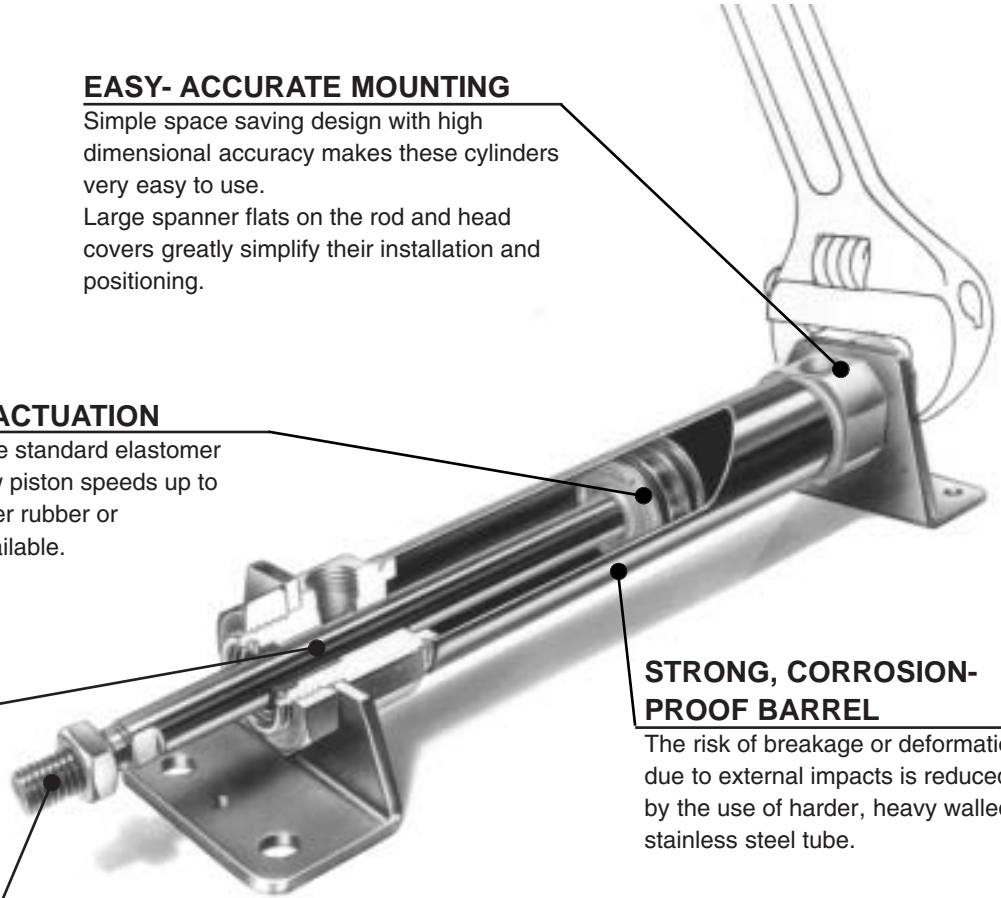

(Head cover)

To realize the rational mounting and the saving space by three or four different head covers.

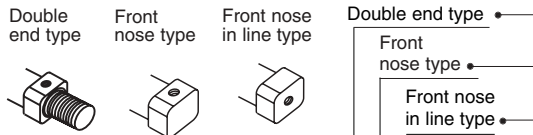

Series	Type	Action	Bore size (mm)		Gaiter	Standard variation
			32	40		
C76	Standard	Double acting: Single rod	●	●	●	●
		Double acting: Double rod	●	●	●	●
		Single acting: Spring return	●	●	●	●
		Single acting: Spring extended	●	●	●	●
		Double acting: Single rod	●	●	●	●
		Single acting: Spring return	●	●	●	●
	Non-rotating	Single acting: Spring return	●	●	●	●
		Single acting: Spring extended	●	●	●	●
		Double acting: Single rod	●	●	●	●
	Direct mounting	Double acting: Single rod	●	●	●	●
		Double acting: Single rod	●	●	●	●
	Mounting bracket	Rod foot / Rod flange (Single)	●	●	●	●
Rod and head foot (Double)		●	●	●	●	
Rod trunnion		●	●	●	●	
Head trunnion		●	●	●	●	
Rod clevis		●	●	●	●	
Head clevis		●	●	●	●	

(Note 1) No double acting: Double rod: Recommendable combination ●

(Note 2) Except for with air cushion

# Variations of C76 Series

Standard (Rubber cushion)			Standard (Air cushion)		Non-rotating		Direct mounting	
Double acting Single rod	Double acting Double rod	Single acting Spring return Spring extended	Double acting Single rod	Double acting Double rod	Double acting Single rod	Single acting Spring return Spring extended	Double acting Single rod	
		 Spring return  Spring extended				 Spring return  Spring extended		
<b>Bore size (mm)</b>	32, 40		32,40		32,40	32,40	32,40	
<b>Type</b>	Non-lubricated							
<b>Mounting (Head cover)</b>	Double end type Front nose type Front nose in line type	Double end type	Spring return/ Double end type Front nose type Front nose in line type Spring extended/ Double end type Front nose type	Double end type	Double end type	Double end type Front nose type Front nose in line type	Spring return/ Double end type Front nose type Front nose in line type Spring extended/ Double end type Front nose type	Front nose type
<b>Built-in magnet</b>	Band mounted type, Rail mounted type						Band mounted type	
<b>Mounting bracket</b>	Rod foot Rod and head foot Rod flange Rod trunnion Head trunnion Rod clevis Head clevis	Rod and head foot Flange Trunnion	Rod foot Rod and head foot Rod flange Rod trunnion Head trunnion Rod clevis Head clevis	Rod foot Rod and head foot Rod flange Rod trunnion Head trunnion Rod clevis Head clevis	Rod and head foot Flange Trunnion	Rod foot Rod and head foot Rod flange Rod trunnion Head trunnion Rod clevis Head clevis	Bottom side mounting Front nose mounting	
<b>Accessories</b>	Standard/Mounting nut, Rod end nut Option/Single knuckle joint, Double knuckle joint (with pin) Floating joint	Standard/Mounting nut, Rod end nut, Option/Single knuckle joint Double knuckle joint (with pin) Floating joint	Standard/Mounting nut, Rod end nut, Option/Single knuckle joint (with pin) Floating joint	Standard/Mounting nut, Rod end nut, Option/Single knuckle joint (with pin) Floating joint	Standard/Mounting nut, Rod end nut, Option/Single knuckle joint (with pin) Floating joint	Standard/Mounting nut, Rod end nut, Option/Single knuckle joint (with pin) Double knuckle joint (with pin) Floating joint	Standard/Rod end nut Option/Single knuckle joint, Double knuckle joint (with pin) Floating joint	
<b>Page</b>	P.4-4		P.4-18		P.4-4		P.4-35	

Quick Reference Guide

C55

C85

C76

CP95

C95

-X  
(Made to Order)

D-  
(Auto Switch)

Model Selection Procedures

# Air cylinder/ Double acting, single and double rod

# Series C76

ø32, ø40

## How to order

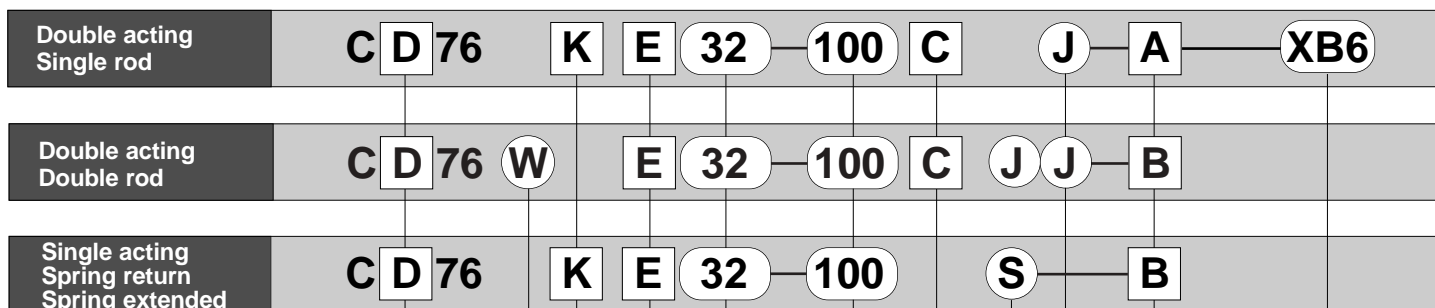

**Magnet**  
 Nil — None  
 D — Built-in magnet

**Type**  
 Nil — Standard.  
 K — Non-rotating (Rubber cushion only).

**Double rod**

**Mounting**

Mark	Mounting
*E	Double end type
**F	Front nose type
**Y	Front nose in line type

\* Double acting/Double rod type: Only double end type. (E).  
 \*\*Except for air cushion type.

**Auto switch mounting type**  
 A — Rail mounted type  
 B — Band mounted type

**Other variations suffix**

XB6	High operating temperature: -10:150°C (Non-magnetic)
XB7	Low operating temperature: -55:70°C available for bores 20 to 25mm
XB9	Low speed
XC6B	Stainless steel piston rod, piston rod nut and mounting nut
XC6A	Stainless steel piston rod and piston rod nut

**Gaiter**

Nil	Without gaiter
J	Nylon tarpaulin one side
K	Neoprene cloth one side
*JJ	Nylon tarpaulin both sides
*KK	Neoprene cloth both sides

\* In case of double acting/double rod.

**Action**  
 S — Spring return  
 T — Spring extended

**Cushion**  
 Nil — Rubber cushion (Standard)  
 C — Air cushion (only "E" execution)

### Parts No. of Mounting Bracket

Mounting bracket	Bore size (mm)		
	32	40	
Mounting bracket	Flange, Foot (1pc.)	C76F32A	C76F40A
	Flange, Foot (2 pcs. with mounting nut 1 pc.)	C76F32B	C76F40B
	Trunnion	C76T32	C76T40
	Clevis	C76C32	C76C40
Accessories	Single knuckle joint	KJ10DA	KJ12DA
	Double knuckle joint	GKM10-20A	GKM12-24A
	Floating joint	JA25-10-150	JA40-12-175

Bore size (mm)	Standard stroke (mm)	Max. stroke (mm)
32	10, 25, 40, 50, 80, 100,	1000
40	125, 160, 200, 250**, 300*	

\* Except single acting type.  
 \*\* Except single acting type, (ø32)

Bore (mm)	Code number		Note
	Standard	Non-rotating	
32	C76-32PS	C76K-32PS	Every set includes: n°1 rod packing n°1 packing retaining washer n°1 retaining ring
40	C76-40PS	C76K-40PS	

Suitable also C76 series

### Example of How to Order

- In case of without auto switch, bore size: 32, stroke: 100, double acting/single rod and double end type.  
 C76E32-100 1 pc. — Cylinder
- In case of without auto switch, bore size: 32, stroke: 50, double acting/double rod, double end type and rod and head foot mounting.  
 C76WE32-50 1 pc. — Cylinder  
 C76L32B 2 pcs. — Foot bracket
- In case of with auto switch (band mounted type, 2 pcs.), bore size: 40, stroke: 100, double acting/single rod, front nose in line type and flange mounting.  
 CD76Y40-100-B 1 pc. — Cylinder  
 C76F40A 1 pc. — Flange mounting  
 D-C73L 2 pcs. — Auto switch  
 BM2-040 2 pcs. — For auto switch mounting band
- In case of with auto switch (rail mounted type, 2 pcs.), bore size: 40, stroke: 50, single acting/spring return, front nose type and trunnion mounting.  
 CD76F40-50S-A 1 pc. — Cylinder  
 C76T40 1 pc. — Trunnion mounting  
 D-A73L 2 pcs. — Auto switch
- Non-rotating : In case of without auto switch, bore size: 32, stroke: 100, double acting/single rod and double end type.  
 C76KE32-100 1 pc. — Cylinder



**Specifications**

<b>Bore size (mm)</b>		<b>32</b>	<b>40</b>
<b>Piston rod dia. (mm)</b>		12	14
<b>Piston rod thread</b>		M10	M12
<b>Ports</b>		G1/8	G1/4
<b>Action</b> Double acting/Single or Double Rod			
<b>Fluid</b> Air			
<b>Proof pressure</b> 1.5MPa {15bar}			
<b>Max operating pressure</b> 1.0MPa {10bar}			
<b>Min operating pressure</b> 0.05MPa {0.5bar}			
<b>Ambient and fluid temperature</b> -20÷80°C (Built-in magnet type: -10÷60°C)			
<b>Cushion</b> Rubber cushion, Air cushion			
<b>Lubrication</b> Not required. If necessary turbine oil #1 ISOVG32 is recommended			
<b>Gaiter</b>	<b>Nylon tarpaulin</b>	Max ambient temperature 60°C	
	<b>Neoprene cloth</b>	Max ambient temperature *110°C	
<b>Piston speed</b>		50÷1500mm/s	
<b>Allowable kinetic energy (J)</b>	<b>Rubber cushion</b>	0.65	1.2
	<b>Air cushion</b>	1.07	2.35
<b>Non-rotating accuracy</b>		±0.5°	±0.5°

\* Maximum ambient temperature of gaiters only.

**Symbol**

**Standard: double action**

Rubber Cushion  
Single rod

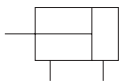

Rubber Cushion  
Double rod

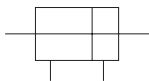

Air Cushion  
Single rod

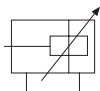

Air Cushion  
Double rod

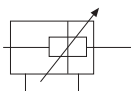

**Non-rotating: Double acting/Single rod**

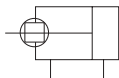

**Weight Table (Standard, Non-rotating)**

(g)

<b>Bore size (mm)</b>		<b>32</b>	<b>40</b>
<b>Basic weight</b>	<b>Single rod</b>	340 (375)	655 (725)
	<b>Double rod</b>	420	810
<b>Additional weight for each 10mm of stroke</b>	<b>Single rod</b>	16.8	26.6
	<b>Double rod</b>	25.6	96.5
<b>Mounting bracket</b>	<b>C75F ○A</b>	110	200
	<b>C75F ○B</b>	240	455
	<b>C75T ○</b>	15	25
	<b>C85C ○</b>	165	305
<b>Accessories</b>	<b>Single knuckle joint</b> KJ ○ D	70	105
	<b>Double knuckle joint</b> GKM ○ -○	100	165
	<b>Floating joint</b> JA ○ -○ -○	70	160

( ) : In case of air cushion

**Calculation Example: C76E32-50, C76F32A**

Basic weight ————— 340 (Ø32)  
 Additional weight ——— 16.8/10mm of stroke  
 Cylinder stroke ————— 50mm  
 Mounting bracket ——— 110  
 340+16.8x50/10=424    424+110=534

**Series C76 Double acting: Single rod**

**C 76 32 ~ 40 Rubber Cushion (Disassembly is not possible)**

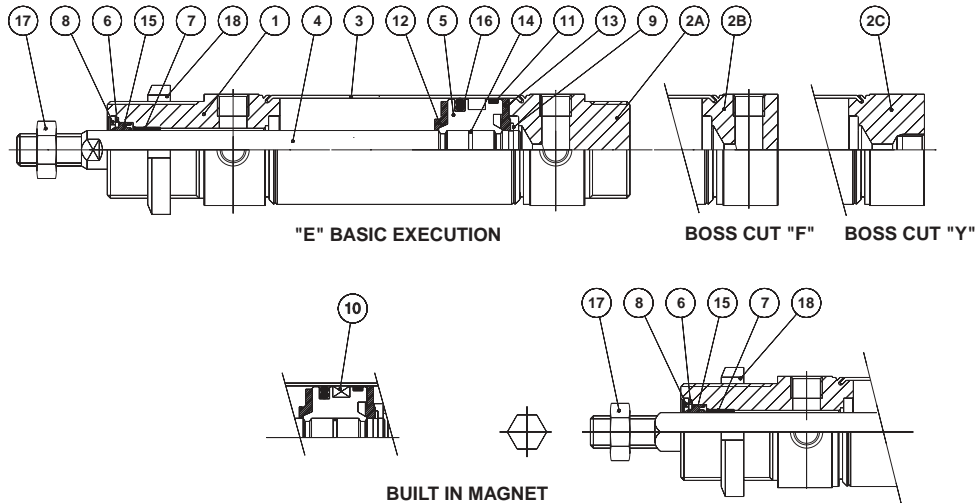

**Parts List**

Item	Part name	Material	Quantity	Remarks
1	Rod cover	Aluminum alloy	1	White alumite
2A	Head cover E	Aluminum alloy	1	White alumite
2B	Head cover F	Aluminum alloy	1	White alumite
2C	Head cover Y	Aluminum alloy	1	White alumite
3	Cylinder tube	Stainless steel	1	
4	Piston rod	Carbon steel	1	Hard chrome plated
5	Piston	Aluminum alloy	1	Chromate
6	Plain washer	Carbon steel	1	Nickel plating
7	Bush	Sintered bronze	1	
8	Retaining ring	Carbon steel	1	Nickel plating

Item	Part name	Material	Quantity	Remarks
9	Retaining ring	Carbon steel	1	Nickel plating
10	Magnet	Magnet	1	(Switch type only)
11	Wear ring	Phenolic resin	1	
12	Bumper A	Urethane	1	
13	Bumper B	Urethane	1	
14	Piston gasket	NBR	1	
15	Rod seal	NBR	1	
16	Piston seal	NBR	1	
17	Rod end nut	Carbon steel	1	Nickel plating
18	Mounting nut	Carbon steel	1	Nickel plating

**C 76 32 ~ 40 Air Cushion (Disassembly is not possible)**

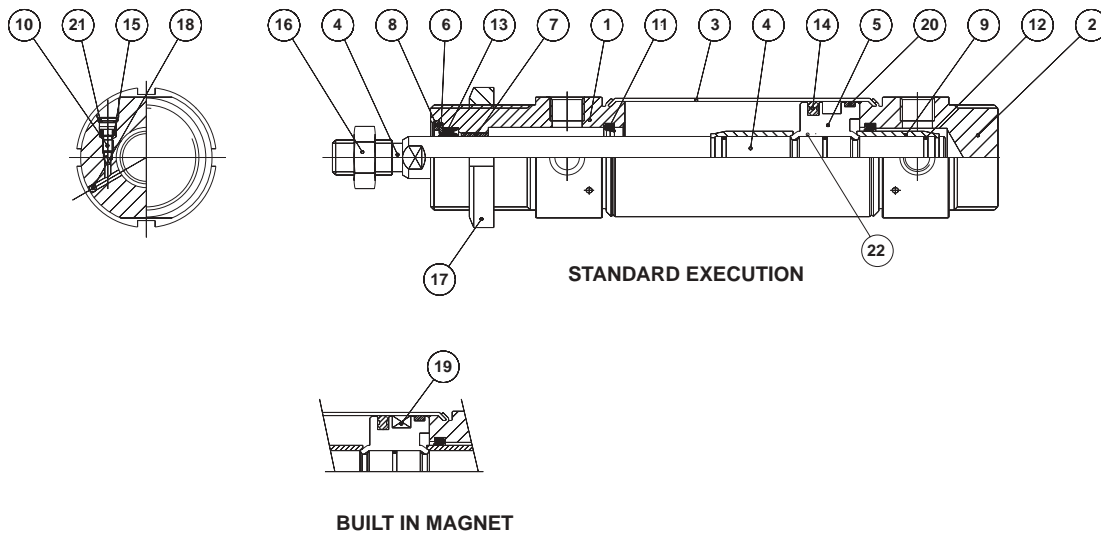

**Parts List**

Item	Part name	Material	Quantity	Remarks
1	Rod cover	Aluminum alloy	1	White alumite
2	Head cover E	Aluminum alloy	1	White alumite
3	Cylinder tube	Stainless steel	1	
4	Piston rod	Carbon steel	1	Hard chrome plated
5	Piston	Aluminum alloy	1	Chromate
6	Plain washer	Carbon steel	1	Nickel plating
7	Bush	Sintered bronze	1	
8	Retaining ring	Carbon steel	1	Nickel plating
9	Cushion ring	Copper alloy	2	
10	Cushion valve	Rolled Steel	2	Kanigen plating
11	Cushion packing	NBR	2	

Item	Part name	Material	Quantity	Remarks
12	Cushion ring gasket	NBR	2	
13	Rod seal	NBR	1	
14	Piston seal	NBR	1	
15	Cushion valve packing	NBR	1	
16	Rod end nut	Carbon steel	1	Nickel plating
17	Mounting nut	Carbon steel	1	Nickel plating
18	Steel ball	Stainless steel	2	
19	Magnet		1	
20	Wear ring	Phenolic resin	1	
21	Retaining ring	Stainless steel	2	
22	Piston gasket	NBR	1	

**C 76 32 ~ 40 Rubber Cushion (Disassembly is not possible)**

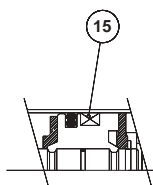
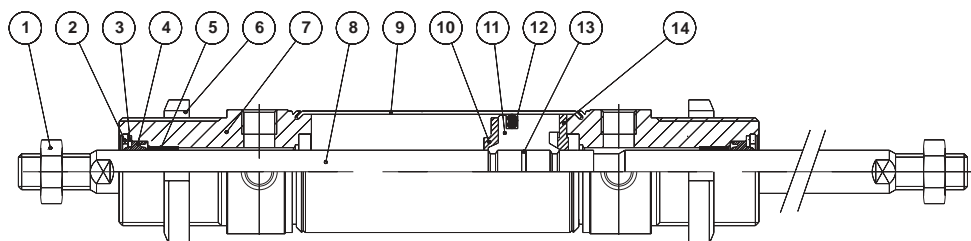

STANDARD EXECUTION

BUILT IN MAGNET

**Parts List**

Item	Part name	Material	Quantity	Remarks
1	Rod end nut	Carbon steel	1	Nickel plating
2	Retaining ring	Carbon steel	2	Nickel plating
3	Plain washer	Carbon steel	2	Nickel plating
4	Rod seal	NBR	2	
5	Bush	Sintered bronze	2	
6	Mounting nut	Carbon steel	1	Nickel plating
7	Rod cover	Aluminum alloy	2	White alumite
8	Piston rod	Stainless steel	1	Hard chrome plated

Item	Part name	Material	Quantity	Remarks
9	Cylinder tube	Stainless steel	1	
10	Bumper A	Urethane	1	
11	Piston	Aluminum alloy	1	Chromate
12	Piston seal	NBR	1	
13	Piston gasket	NBR	1	
14	Bumper B	Urethane	1	
15	Magnet		1	(Switch type only)

**C 76 32 ~ 40 Air Cushion (Disassembly is not possible)**

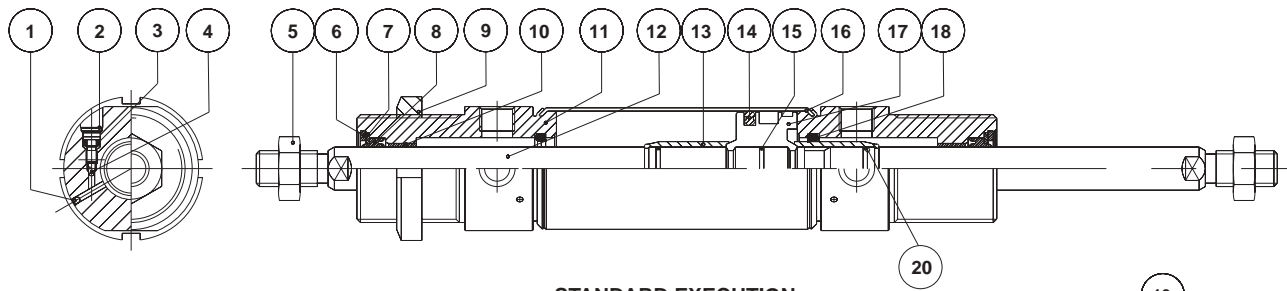

STANDARD EXECUTION

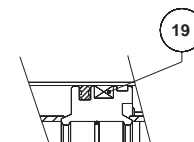

BUILT IN MAGNET

**Parts List**

Item	Part name	Material	Quantity	Remarks
1	Steel ball	Stainless steel	2	
2	Retaining ring	Stainless steel	2	
3	Cushion valve packing	NBR	2	
4	Cushion valve	Rolled steel	2	Kaunigen plating
5	Rod end nut	Carbon steel	2	Nickel plating
6	Retaining ring	Carbon steel	2	Nickel plating
7	Plain washer	Carbon steel	2	Nickel plating
8	Rod seal	NBR	2	
9	Mounting nut	Carbon steel	1	Nickel plating
10	Bush	Sintered bronze	2	

Item	Part name	Material	Quantity	Remarks
11	Rod cover	Aluminum alloy	2	White alumite
12	Piston rod	Carbon steel	1	Hard chrome plated
13	Cushion ring	Copper alloy	2	Hard chrome plated
14	Piston seal	NBR	1	
15	Piston gasket	NBR	1	
16	Cylinder tube	Stainless steel	1	
17	Piston	Aluminum alloy	1	Chromate
18	Cushion packing	NBR	2	
19	Magnet		1	
20	Cushion ring gasket	NBR	2	

**Series C76** Double acting: Single rod

**C76E** Double end type, Standard, Non-rotating

**Dimensions**

Rubber Cushion/ C76E Bore – Stroke –  
Without Magnet, Built-in Magnet

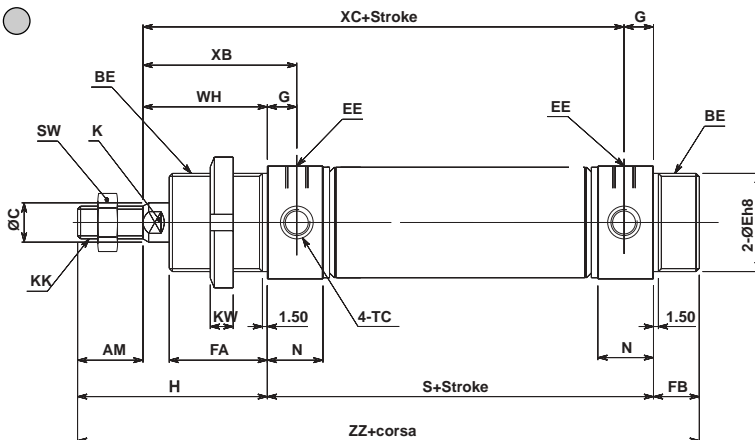
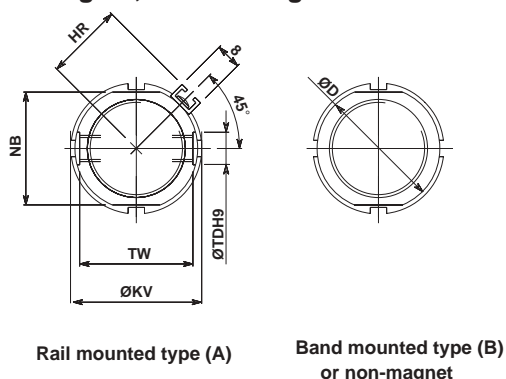

Air Cushion / C76E Bore – Stroke C –  
Without Magnet, Built-in Magnet

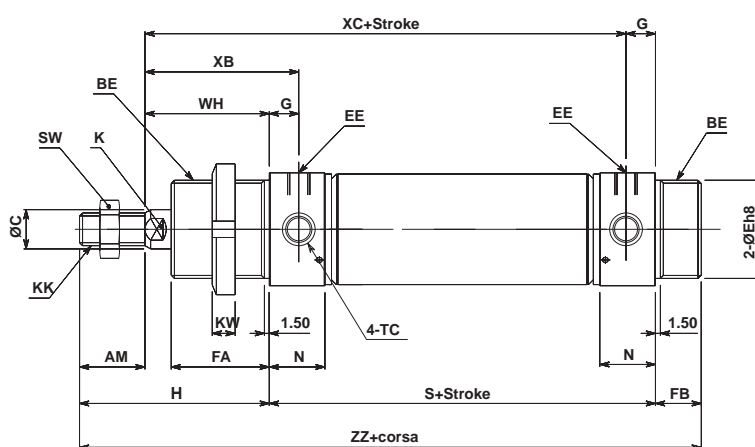
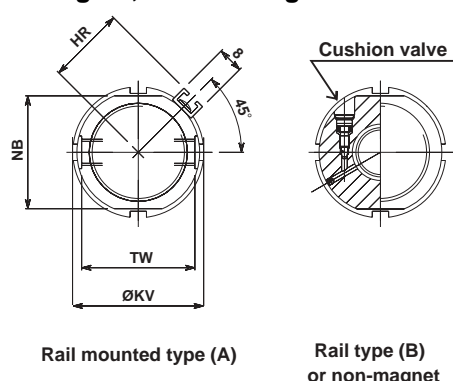

With Gaiter

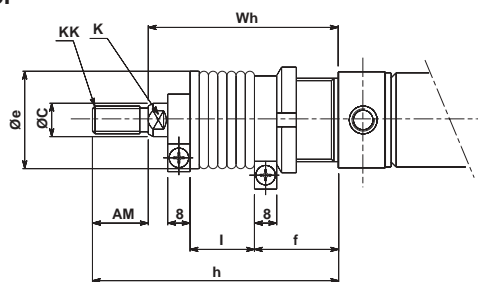

**C76KE**  
Non-rotating, Piston rod (Rubber Cushion Only)

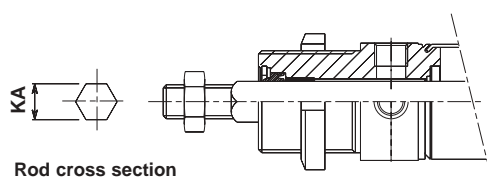

Unit:mm

Bore	AM	BE	ØC	ØD	ØEh8	EE	FA	FB	G	H	HR	K	KA	KK	ØKV	KW	N	NB	S	SW	TC	ØTDH9	TW	WH	XB	XC	ZZ
32	20	M30x1.5	12	37.5	30 <sup>-0.033</sup>	G1/8	30	14	9	58	23.8	10	12.2	M10	38	7	17(19)	34.5	68	17	M8x1	10	34.5	38	47	97	140
40	24	M38x1.5	14	46.5	38 <sup>-0.039</sup>	G1/4	35	16	12	69	28.3	12	14.2	M12	50	8	22(25)	42.5	89	19	M10x1	12	42.5	45	57	122	174

( ): In case of air cushion

With Gaiter

Bore	Item Stroke	AM	ØC	Øe	f	K	KK	h						
								1~50	51~100	101~150	151~200	201~300	301~400	401~500
32		20	12	35	30	10	M10	77	90	102	115	140	165	190
40		24	14	46	35	12	M12	88	101	113	126	151	176	201

Bore	Item Stroke	I							Wh						
		1~50	51~100	101~150	151~200	201~300	301~400	401~500	1~50	51~100	101~150	151~200	201~300	301~400	401~500
32		12.5	25	37.5	50	75	100	125	57	70	82	95	120	145	170
40		12.5	25	37.5	50	75	100	125	64	77	89	102	127	152	177



C76E Accessories

**Dimensions with mounting brackets**

Rod Foot Flange, Rod And Head Foot: C76F32<sup>A</sup><sub>B</sub>, C76F40<sup>A</sup><sub>B</sub>

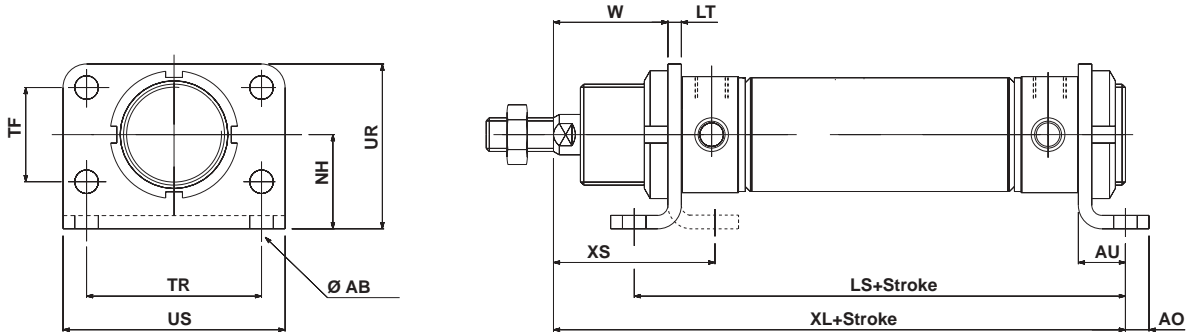

Rod Trunnion, Head Trunnion: C76T32, C76T40

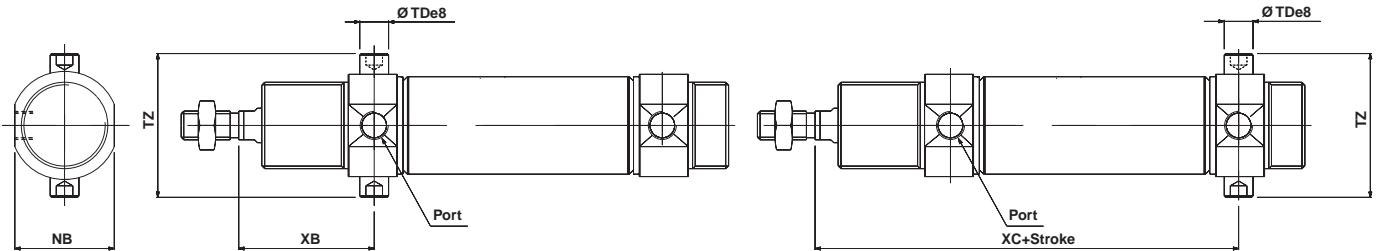

Rod clevis, Head clevis: C76C32, C75C40

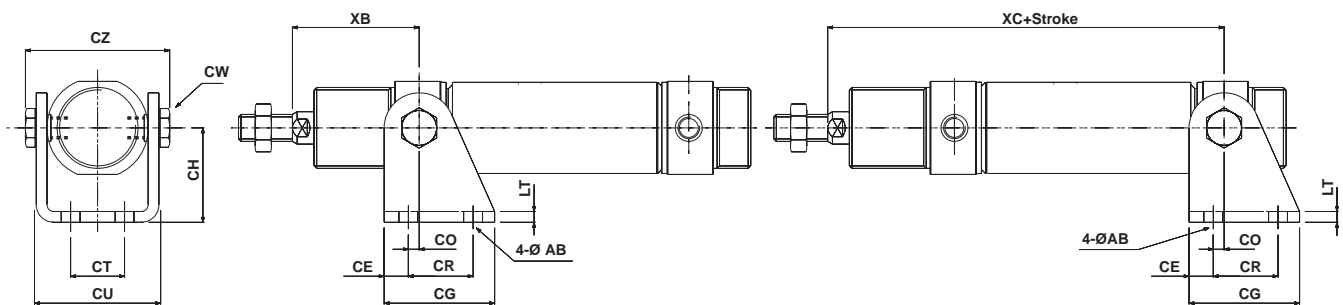

Unit:mm

Bore	Rod foot (flange)											Rod/head trunnion					Rod clevis, Head clevis														
	ØAB	AO	AU	LS	LT	NH	TF	TR	UR	US	W	XL	XS	NB	ØTDe8	TZ	XB	XC	ØAB	CE	CG	CH	CO	CR	CT	CU	CW	CZ	LT	XB	XC
32	7	7	14	96	4	28	28	52	49	66	34	120	48	34.5	10 <sup>-0.025</sup> <sub>-0.047</sub>	47.9	47	97	7	9	41	35	4	24	20	46.8	13	57.9	4	47	97
40	9	10	20	129	5	33	30	60	58	80	40	154	60	42.5	12 <sup>-0.032</sup> <sub>-0.059</sub>	59.3	57	122	9	12	52	40	3	30	28	58.2	17	72.3	5	57	122

**Series C76** Double acting: Single rod

**C76F** Front nose type, Standard, Non-rotating

**Dimensions**

Rubber Cushion/ C76F **Bore** – **Stroke** – **Without Magnet, Built-in Magnet**

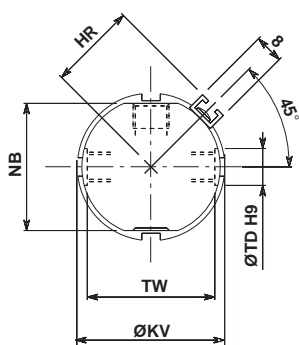

Rail mounted type (A)

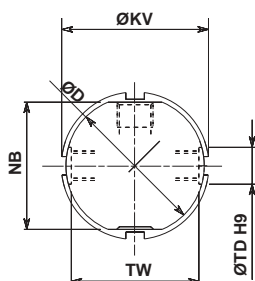

Band mounted type (B)  
or non-magnet

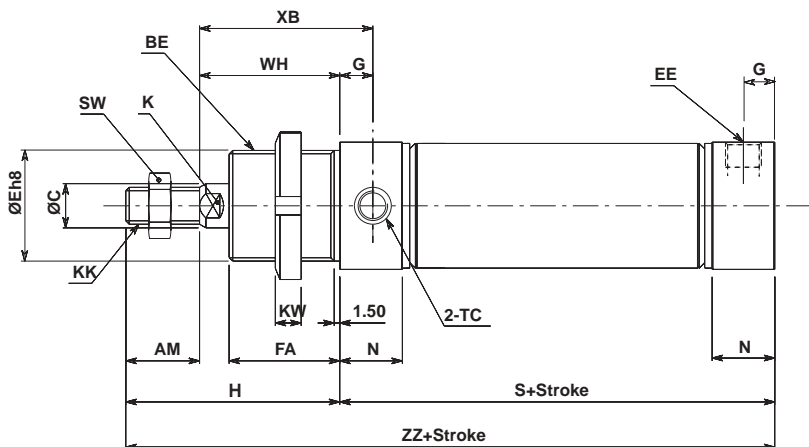

**With Gaiter**

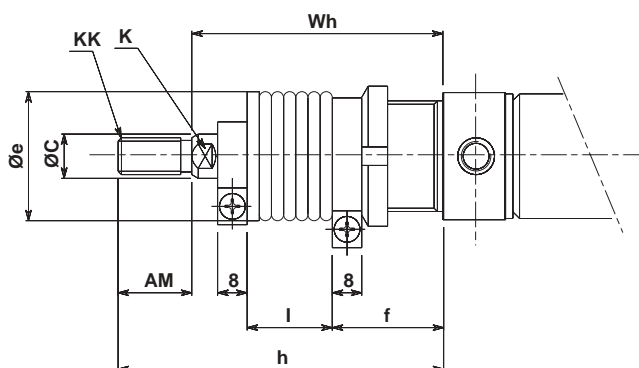

**C76KF**  
Non-rotating, Piston rod

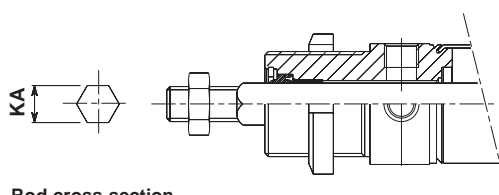

Rod cross section

Unit:mm

Bore	AM	BE	ØC	ØD	ØEh8	EE	FA	G	H	HR	K	KA	KK	ØKV	KW	N	NB	S	SW	TC	ØTDH9	TW	WH	XB	ZZ
32	20	M30x1.5	12	37.5	30 <sup>0</sup> <sub>-0.033</sub>	G1/8	30	9	58	23.8	10	12.2	M10	38	7	17	34.5	68	17	M8x1	10 <sup>+0.036</sup> <sub>0</sub>	34.5	38	47	126
40	24	M38x1.5	14	46.5	38 <sup>0</sup> <sub>-0.039</sub>	G1/4	35	12	69	28.3	12	14.2	M12	50	8	22	42.5	89	19	M10x1	12 <sup>+0.036</sup> <sub>0</sub>	42.5	45	57	158

**With Gaiter**

Bore	Item Stroke	AM	ØC	Øe	f	K	KK	h						
								1~50	51~100	101~150	151~200	201~300	301~400	401~500
32		20	12	35	30	10	M10	77	90	102	115	140	165	190
40		24	14	46	35	12	M12	88	101	113	126	151	176	201

Bore	Item Stroke	l							Wh						
		1~50	51~100	101~150	151~200	201~300	301~400	401~500	1~50	51~100	101~150	151~200	201~300	301~400	401~500
32		12.5	25	37.5	50	75	100	125	57	70	82	95	120	145	170
40		12.5	25	37.5	50	75	100	125	64	77	89	102	127	152	177

**C76F Accessories**

**Dimensions with mounting brackets**

**Rod Foot (flange): C76F32A, C76F40A**

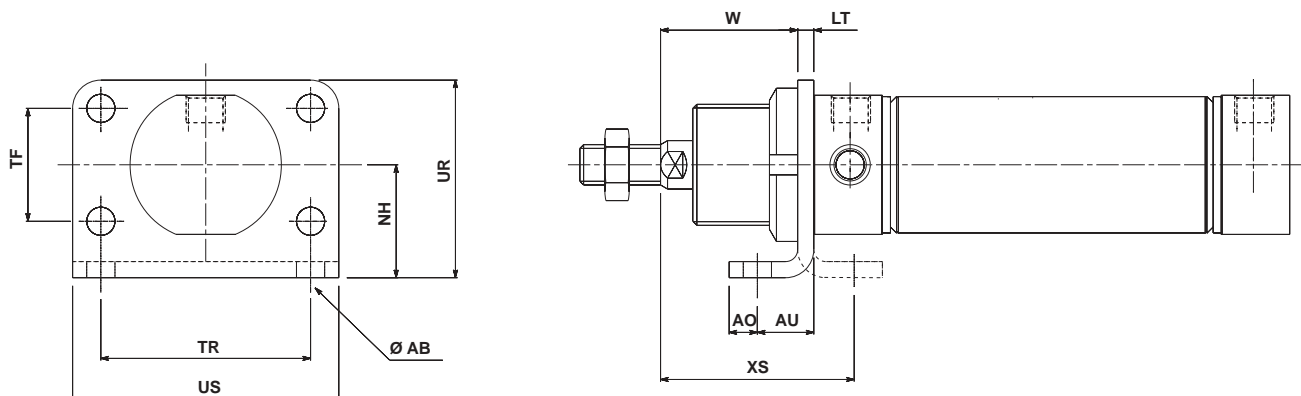

**Rod Trunnion: C76T32, C76T40**

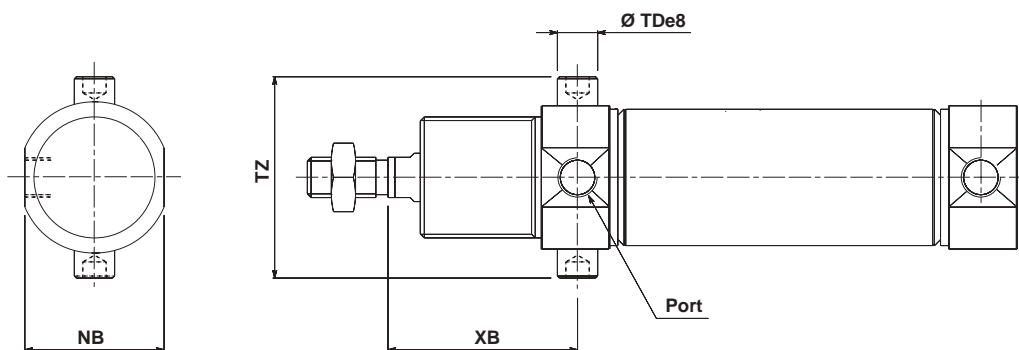

**Rod Clevis: C76C32, C76C40**

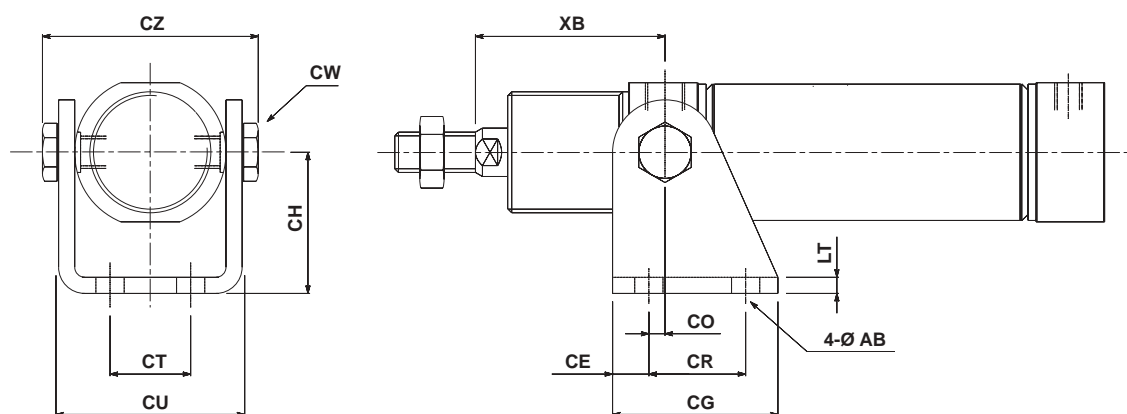

Unit:mm

Bore	Rod foot (flange)									Rod Trunnion				Rod clevis													
	ØAB	AO	AU	LT	NH	TF	TR	UR	US	W	XS	NB	ØTDe8	TZ	XB	ØAB	CE	CG	CH	CO	CR	CT	CU	CW	CZ	LT	XB
32	7	7	14	4	28	28	52	49	66	34	48	34.5	10 <sup>-0.025</sup> <sub>-0.047</sub>	47.9	47	7	9	41	35	4	24	20	46.8	13	57.9	4	47
40	9	10	20	5	33	30	60	58	80	40	60	42.5	12 <sup>-0.032</sup> <sub>-0.059</sub>	59.3	57	9	12	52	40	3	30	28	58.2	17	72.3	5	57

**Series C76** Double acting: Single rod

**C76Y** Front nose in line type, Standard, Non-rotating

**Dimensions**

Rubber Cushion/C76Y **Bore** – **Stroke** – **Without Magnet, Built-in Magnet**

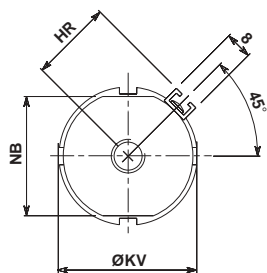

Rail mounted type (A)

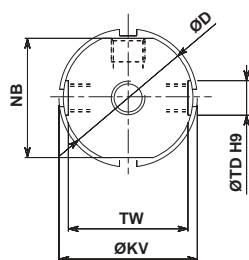

Band mounted type (B)  
or non-magnet

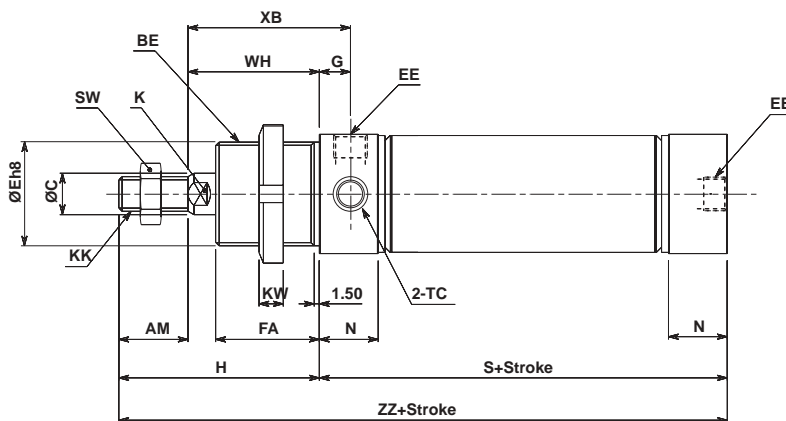

**With Gaiter**

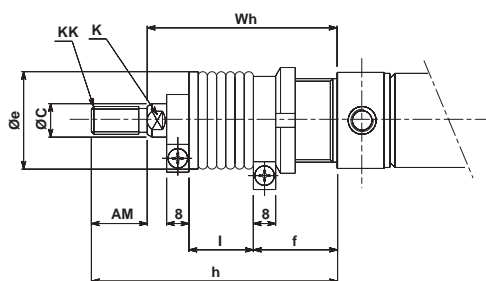

**C76KY**

**Non-rotating, Piston rod**

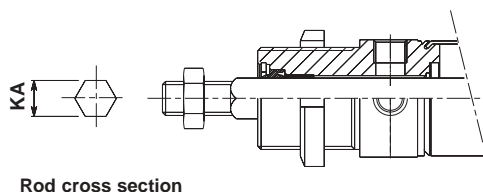

Rod cross section

Unit:mm

Bore	AM	BE	ØC	ØD	ØEh8	EE	FA	G	H	HR	K	KA	KK	ØKV	KW	N	□NB	S	SW	TC	ØTDH9	TW	WH	XB	ZZ
32	20	M30x1.5	12	37.5	30 <sup>0</sup> <sub>-0.033</sub>	G1/8	30	9	58	23.8	10	12.2	M10	38	7	17	34.5	68	17	M8x1	10 <sup>+0.036</sup> <sub>0</sub>	34.5	38	47	126
40	24	M38x1.5	14	46.5	38 <sup>0</sup> <sub>-0.039</sub>	G1/4	35	12	69	28.3	12	14.2	M12	50	8	22	42.5	89	19	M10x1	12 <sup>+0.036</sup> <sub>0</sub>	42.5	45	57	158

**With Gaiter**

Bore	Item Stroke	AM	ØC	Øe	f	K	KK	h						
								1~50	51~100	101~150	151~200	201~300	301~400	401~500
32		20	12	35	30	10	M10	77	90	102	115	140	165	190
40		24	14	46	35	12	M12	88	101	113	126	151	176	201

Bore	Item Stroke	l							Wh						
		1~50	51~100	101~150	151~200	201~300	301~400	401~500	1~50	51~100	101~150	151~200	201~300	301~400	401~500
32		12.5	25	37.5	50	75	100	125	57	70	82	95	120	145	170
40		12.5	25	37.5	50	75	100	125	64	77	89	102	127	152	177

**C76Y Accessories**

**Dimensions with mounting brackets**

**Rod Foot (flange): C76F32A, C76F40A**

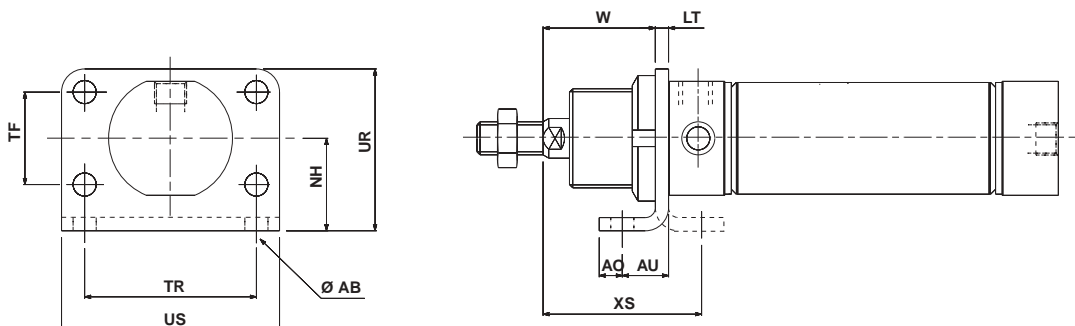

**Rod Trunnion: C76T32, C76T40**

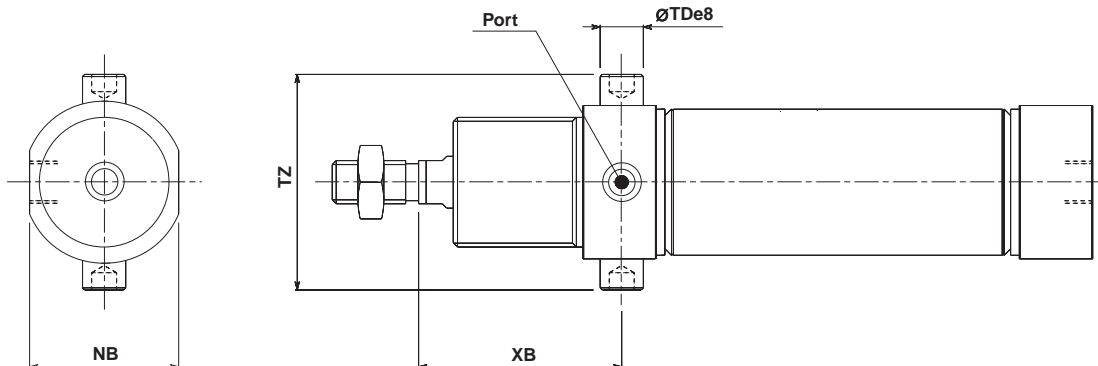

**Rod Clevis: C76C32, C76C40**

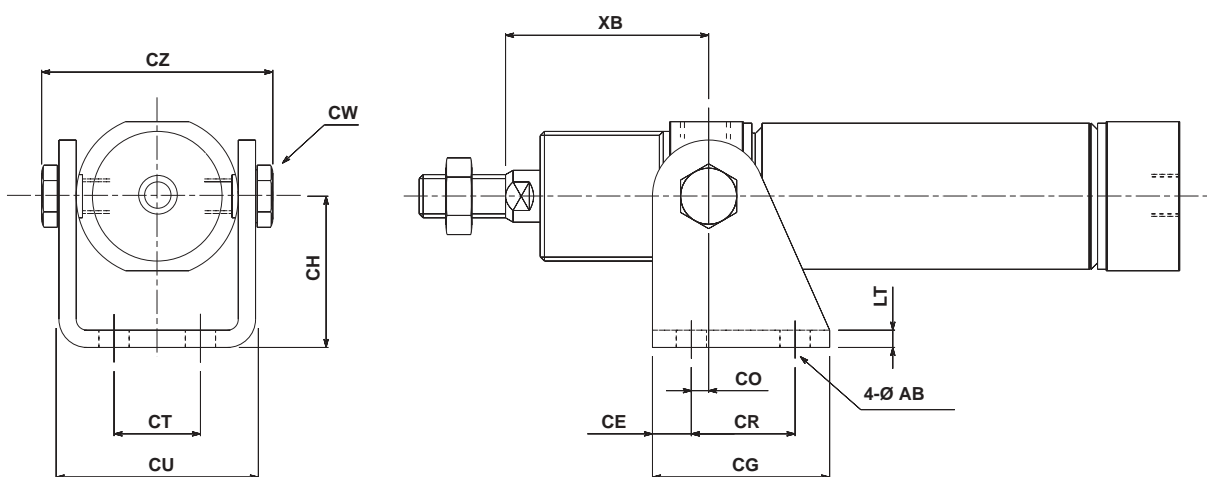

Unit:mm

Bore	Rod foot (flange)										Rod trunnion				Rod clevis												
	ØAB	AO	AU	LT	NH	TF	TR	UR	US	W	XS	NB	ØTDe8	TZ	XB	ØAB	CE	CG	CH	CO	CR	CT	CU	CW	CZ	LT	XB
32	7	7	14	4	28	28	52	49	66	34	48	34.5	10 <sup>-0.025</sup> <sub>-0.047</sub>	47.9	47	7	9	41	35	4	24	20	46.8	13	57.9	4	47
40	9	10	20	5	33	30	60	58	80	40	60	42.5	12 <sup>-0.032</sup> <sub>-0.059</sub>	59.3	57	9	12	52	40	3	30	28	58.2	17	72.3	5	57

Series **C76** Double acting: Double rod

C○76WE Double end type/Standard

Dimensions

Rubber Cushion/C○76WE **Bore** - **Stroke** - ○

Without Magnet, Built-in Magnet

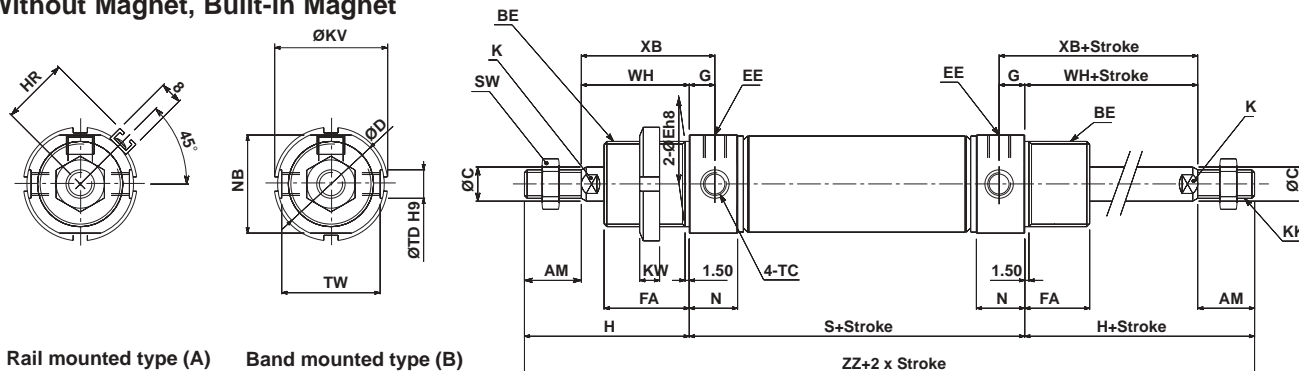

Air Cushion/C○76WE **Bore** - **Stroke** C - ○

Built-in Magnet

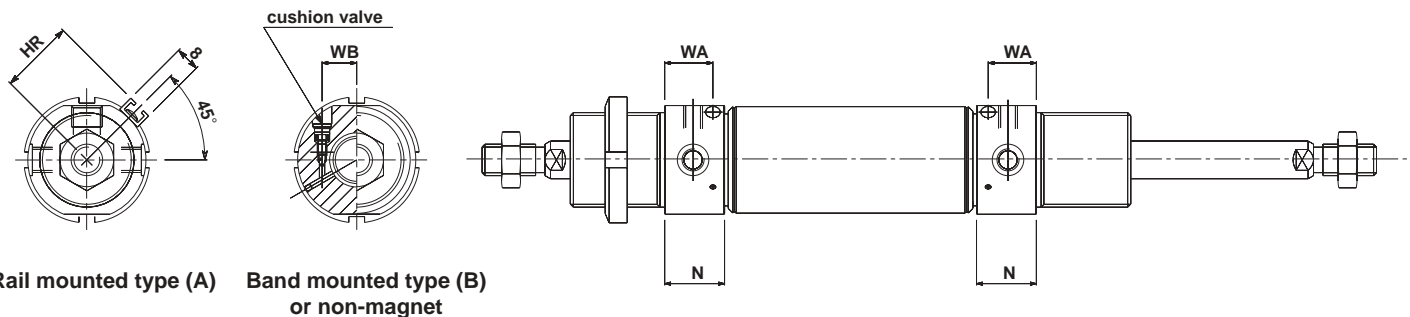

With Gaiter

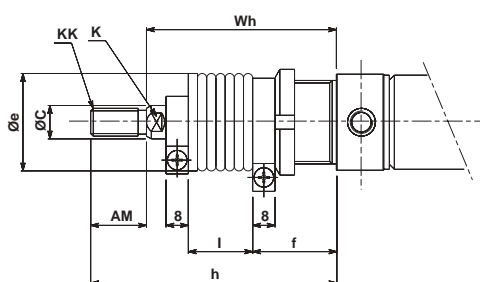

Unit:mm

Bore	AM	BE	ØC	ØD	ØEh8	EE	FA	G	H	HR	K	KK	ØKV	WB	KW	N	NB	S	SW	TC	ØTDH9	TW	WH	XB	ZZ	WA
32	20	M30x1.5	12	37.5	30 <sup>0</sup> <sub>-0.033</sub>	G1/8	30	9	58	23.8	10	M10	38	11	7	17(19)	34.5	68	17	M8x1	10 <sup>0</sup> <sub>-0.036</sub>	34.5	38	47	184	15.3
40	24	M38x1.5	14	46.5	38 <sup>0</sup> <sub>-0.038</sub>	G1/4	35	12	69	28.3	12	M12	50	13	8	22(25)	42.5	89	19	M10x1	12 <sup>0</sup> <sub>-0.043</sub>	42.5	45	57	227	20

( ) : in case of air cushion

With Gaiter

Bore	Item Stroke	AM	ØC	Øe	f	K	KK	h						
								1~50	51~100	101~150	151~200	201~300	301~400	401~500
32		20	12	35	30	10	M10	77	90	102	115	140	165	190
40		24	14	46	35	12	M12	88	101	113	126	151	176	201

Bore	Item Stroke	l							Wh						
		1~50	51~100	101~150	151~200	201~300	301~400	401~500	1~50	51~100	101~150	151~200	201~300	301~400	401~500
32		12.5	25	37.5	50	75	100	125	57	70	82	95	120	145	170
40		12.5	25	37.5	50	75	100	125	64	77	89	102	127	152	177

**C76E Accessories**

**Dimensions with mounting brackets**

Rod Foot, Rod And Head Foot: C76F32<sup>A</sup><sub>B</sub>, C76F40<sup>A</sup><sub>B</sub>

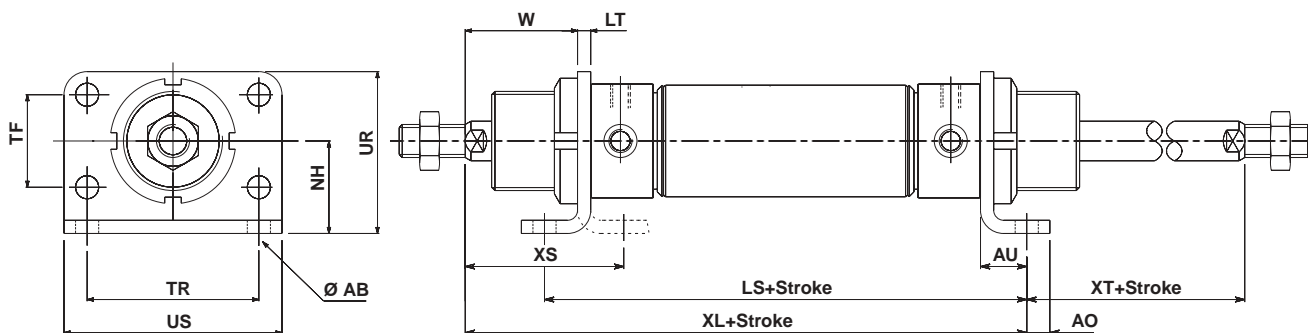

Rod Trunnion, Head Trunnion: C76T32, C76T40

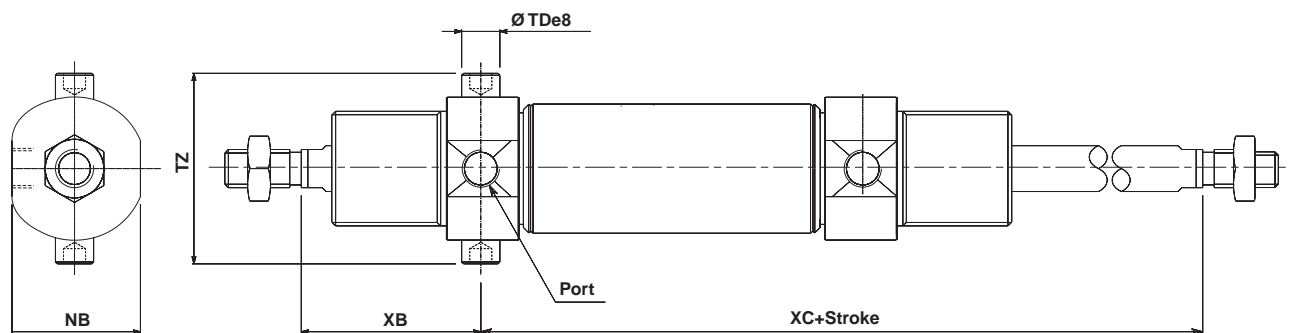

Rod clevis, Head clevis: C76C32, C75C40

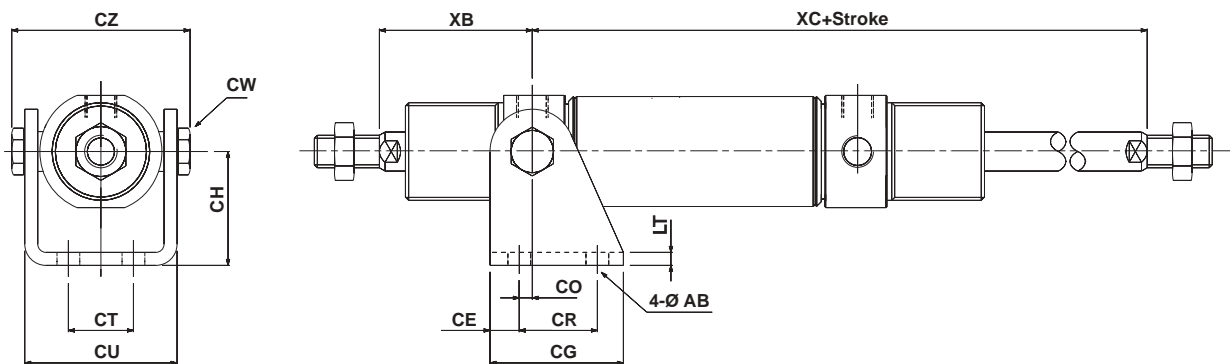

Unit:mm

Bore	Rod foot (flange)										Rod trunnion						Clevis															
	ØAB	AO	AU	LS	LT	NH	TF	TR	UR	US	W	XL	XS	XT	NB	ØTDe8	TZ	XB	XC	ØAB	CE	CG	CH	CO	CR	CT	CU	CW	CZ	LT	XB	XC
32	7	7	14	96	4	28	28	52	49	66	34	120	48	24	34.5	10 <sup>-0.025</sup> <sub>-0.047</sub>	47.9	47	97	7	9	41	35	4	24	20	46.8	13	57.9	4	47	97
40	9	10	20	129	5	33	30	60	58	80	40	150	60	25	42.5	12 <sup>-0.032</sup> <sub>-0.059</sub>	59.3	57	122	9	12	52	40	3	30	28	58.2	17	72.3	5	57	122

**Series C76** Double acting: Double rod

**Accessories/Dimensions**

**Single Knuckle Joint/DIN648**

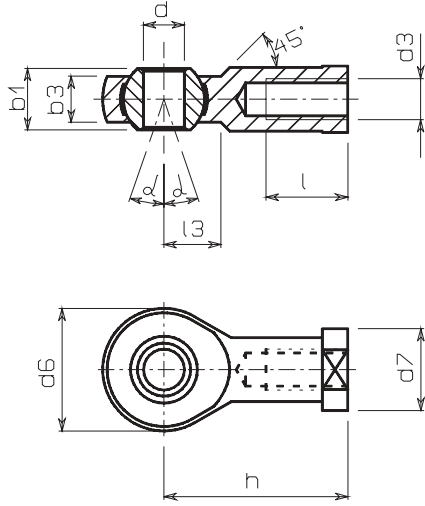

**Double Knuckle Joint/DIN71751**

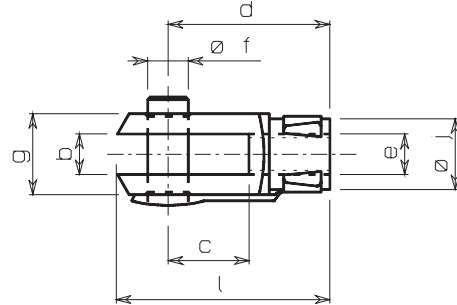

Unit: mm

Bore Size	Model	Thread d3	dH71	h	d6	b3	b1	l	d7	α°	l3
Ø32	KJ10DA	M10	10	43	28	10.5	14	20	19	13	14
Ø40	KJ12DA	M12	12	50	30	12	16	22	22	13	16

Unit: mm

Bore Size	Model	Thread e	b	d	f	g	c	j	a
Ø32	GKM10-20A	M10	10	40	10	18	20	12	20
Ø40	GKM12-24A	M12	12	48	12	23	24	15	24

**Floating-Joint/Series JA**

**JA25•40**

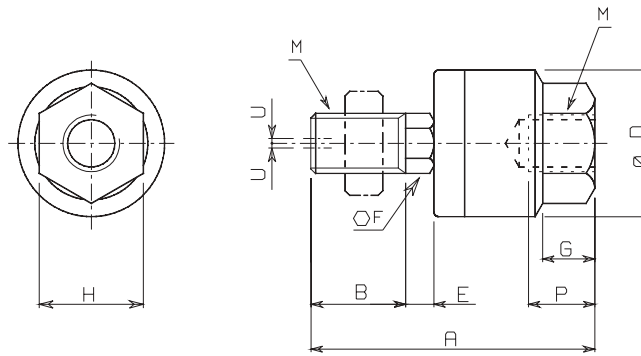

Unit: mm

Bore Size	Model	M		A	B	D	E	F	G	H	Maximum screwed depth P	Allowable eccentricity U	Max. operating tension and compression power kgf (KN)
		Nominal thread dia.	Pitch										
Ø32	JA25-10-150	10	1.5	49.5	19.5	24	5	8	8	17	9	0.5	250 (2.5)
Ø40	JA40-12-175	12	1.75	60	20	31	6	11	11	22	13	0.75	440 (4.4)





Single acting: spring return/spring extended

# Series C76

Bore size: ø32, ø40

## Specifications



Bore size (mm)	32	40
Piston rod dia. (mm)	12	14
Piston rod thread	M10	M12
Ports	G1/8	G1/4
Action	Single acting/single rod, spring return, spring extended	
Fluid	Air	
Proof pressure	1.5MPa {15bar}	
Max operating pressure	1.0MPa {10bar}	
Min operating pressure	Spring return: 0.18MPa (1.8bar) spring extended: 0.23MPa (2.3bar)	
Ambient and fluid temperature	-20÷80°C (Built-in magnet type: -10÷60°C)	
Lubrication	None (Non lubricated)	
Piston speed	50÷750mm/s	
Allowable kinetic energy (J)	0.65	1.2
Non-rotating accuracy	±0.5°	±0.5°

## Symbol

### Standard

Spring return

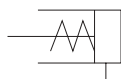

Spring extended

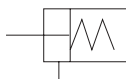

### Non-rotating

Spring return

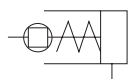

Spring extended

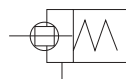

## Spring force (Standard, Non-rotating)

### Spring return

(N)

Bore size (mm)	Standard stroke	Spring force															
		10		25		50		100		150		200		250			
		Extended position	Retracting position	Extended position	Retracting position	Extended position	Retracting position	Extended position	Retracting position	Extended position	Retracting position	Extended position	Retracting position	Extended position	Retracting position		
32	10, 25,																
	50, 100	53.9	48.8	53.9	41.2	53.9	28.4	66.7	19.6	66.7	18.1	66.7	19.6	—	—		
	150, 200																
40	10, 25																
	50, 100	78.5	72.6	78.5	63.7	78.5	49	76.5	23.5	76.5	23.5	76.5	23.5	76.5	23.5		
	150, 200																
	250																

### Spring extended

(N)

Bore size (mm)	Standard stroke	Spring force															
		10		25		50		100		150		200		250			
		Extended position	Retracting position	Extended position	Retracting position	Extended position	Retracting position	Extended position	Retracting position	Extended position	Retracting position	Extended position	Retracting position	Extended position	Retracting position		
32	10, 25,																
	50, 100	66.7	56.3	66.7	40.7	66.7	14.7	66.7	19.6	66.7	18.1	66.7	19.6	—	—		
	150, 200																
40	10, 25																
	50, 100	76.5	65.9	76.5	50	76.5	23.5	76.5	23.5	76.5	23.5	76.5	23.5	76.5	23.5		
	150, 200																
	250																

**Weigh table**

**Spring Return**

(g)

Bore size		32	40	
Basic weight	10 stroke	365	700	
	25 stroke	390	735	
	50 stroke	430	805	
	100 stroke	685	1185	
	150 stroke	860	1450	
	200 stroke	1025	1705	
	250 stroke	—	1960	
Mounting bracket	C76FOA	110	200	
	C76FOB	240	455	
	C76TO	15	25	
	C76CO	165	305	
Accessories	Single knuckle joint	KJOD	70	105
	Double knuckle joint	GKMO-OA	100	165
	Floating joint	JAO-O-O	70	160

**Calculation (Example)** C76E32-50S, C76T32

Base weight ————— 430 (Ø32)  
 Mounting bracket ————— 15  
 430+15=445

**Spring Extended**

(g)

Bore size		32	40	
Basic weight	10 stroke	430	795	
	25 stroke	455	835	
	50 stroke	495	900	
	100 stroke	640	1125	
	150 stroke	795	1360	
	200 stroke	940	1585	
	250 stroke	—	1720	
Mounting bracket	C76FOA	110	200	
	C76FOB	240	455	
	C76TO	15	25	
	C76CO	165	305	
Accessories	Single knuckle joint	KJODA	70	105
	Double knuckle joint	GKMO-OA	100	165
	Floating joint	JAO-O-O	70	160

**Calculation (Example)** C76F40-100T, C76C40, KJ12DA

Base weight ————— 11250(Ø40)  
 Mounting bracket ————— 305  
 Single knuckle joint ————— 105  
 1125+305+105=1535

Quick Reference Guide

C55

C85

**C76**

CP95

C95

-X (Made to Order)

D- (Auto Switch)

Model Selection Procedures

**Series C76** Simple acting: Spring Return/Spring Extended

C 76 32,40-50S Spring return

50mm stroke or less

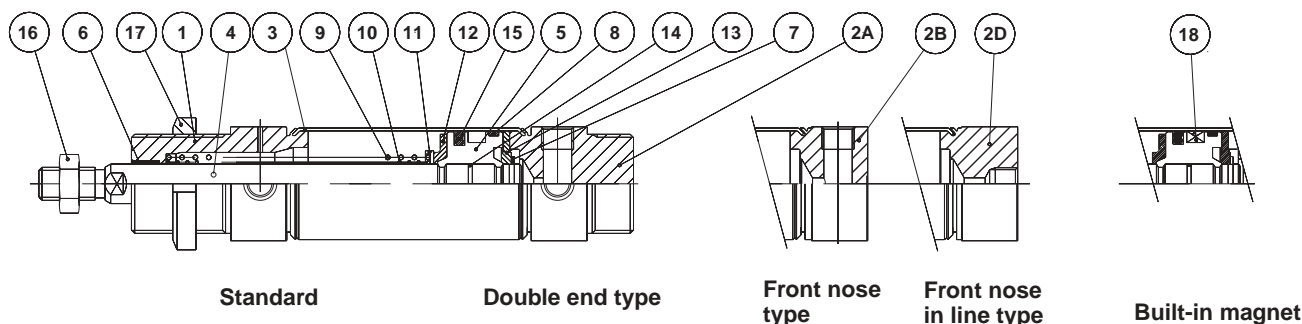

**Parts List**

Item	Part name	Material	Quantity	Remarks
1	Rod cover	Aluminum alloy	1	White alumite
2A	Head cover E	Aluminum alloy	1	White alumite
2B	Head cover F	Aluminum alloy	1	White alumite
2D	Head cover Y	Aluminum alloy	1	White alumite
3	Cylinder tube	Stainless steel	1	
4	Piston rod	Carbon steel	1	Hard chrome plated
5	Piston	Aluminum alloy	1	Chromate
6	Bush	Sintered bronze	1	
7	Retaining ring	Carbon steel	1	
8	Wear ring	Phenolic resin	2	

Item	Part name	Material	Quantity	Remarks
9	Return spring A	Steel wire	1	Chromate
10	Return spring B	Steel wire	1	Chromate
11	Spring holder	Carbon steel	1	Zinc chromate
12	Bumper A	Urethane	1	
13	Bumper B	Urethane	1	
14	Piston gasket	NBR	1	
15	Piston seal	NBR	1	
16	Rod end nut	Carbon steel	1	Nickel plating
17	Mounting nut	Carbon steel	1	Nickel plating
18	Magnet			

C 76 32;40-S Spring return

over 50mm stroke

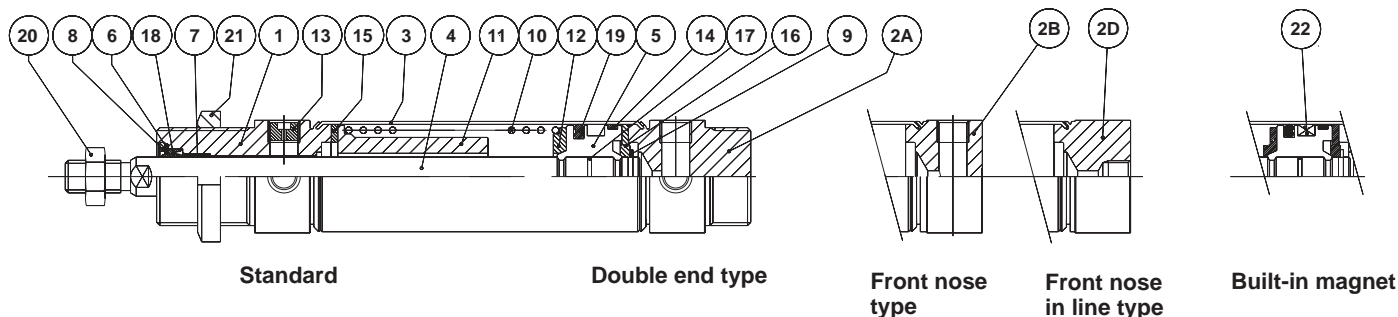

**Parts List**

Item	Part name	Material	Quantity	Remarks
1	Rod cover	Aluminum alloy	1	White alumite
2A	Head cover E	Aluminum alloy	1	White alumite
2B	Head cover F	Aluminum alloy	1	White alumite
2D	Head cover Y	Aluminum alloy	1	White alumite
3	Cylinder tube	Stainless steel	1	
4	Piston rod	Carbon steel	1	Hard chrome plated
5	Piston	Aluminum alloy	1	Chromate
6	Plain washer	Carbon steel	1	
7	Bush	Sintered bronze	1	
8	Retaining ring	Carbon steel	1	
9	Retaining ring	Carbon steel	1	Chromate
10	Return spring	Steel wire	1	Chromate
11	Spring guide	Aluminum alloy	1	Zinc chromate
12	Spring holder	Aluminum alloy	1	

Item	Part name	Material	Quantity	Remarks
13	Set screw	Carbon steel	1	
14	Wear ring	Phenolic resin	1	
15	Bumper A	Urethane	1	
16	Bumper B	Urethane	1	
17	Piston gasket	NBR	1	
18	Rod seal	NBR	1	
19	Piston seal	NBR	1	
20	Rod end nut	Carbon steel	1	Nickel plating
21	Mounting nut	Carbon steel	1	Nickel plating
22	Magnet			

**C 76 32,40 T Spring extended**

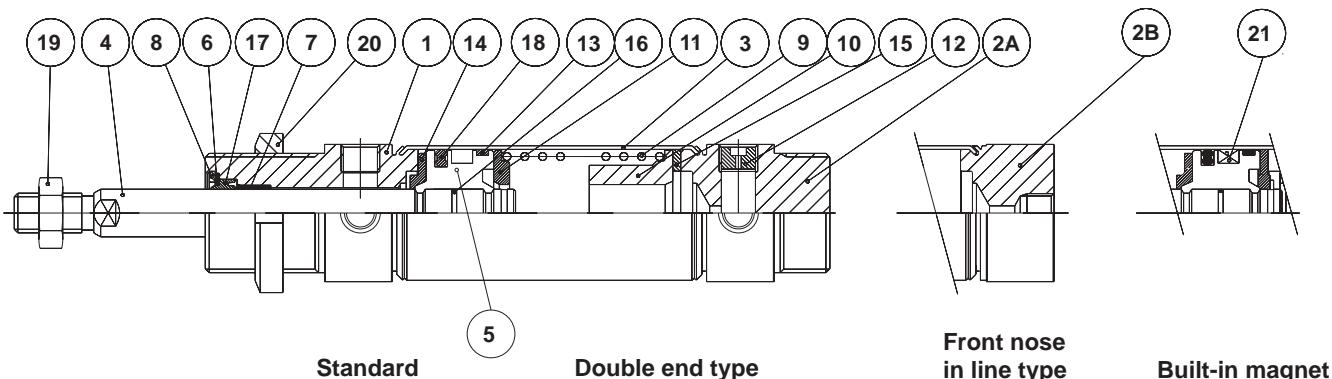

**Parts List**

Item	Part name	Material	Quantity	Remarks
1	Rod cover	Aluminum alloy	1	White alumite
2A	Head cover E	Aluminum alloy	1	White alumite
2B	Head cover F	Aluminum alloy	1	White alumite
3	Cylinder tube	Stainless steel	1	
4	Piston rod	Carbon steel	1	Hard chrome plated
5	Piston	Aluminum alloy	1	Chromate
6	Plain washer	Carbon steel	1	Nickel plating
7	Bush	Sintered bronze	1	
8	Retaining ring	Carbon steel	1	Nickel plating
9	Return spring	Steel wire	1	Zinc chromate
10	Spring guide	Aluminium alloy	1	
11	Spring holder	Aluminium alloy	1	
12	Set screw	Carbon steel	1	

Item	Part name	Material	Quantity	Remarks
13	Wear ring	Phenolic resin	1	
14	Bumper A	Urethane	1	
15	Bumper B	Urethane	1	
16	Piston gasket	NBR	1	
17	Rod seal	NBR	1	
18	Piston seal	NBR	1	
19	Rod end nut	Carbon steel	1	Nickel plating
20	Mounting nut	Carbon steel	1	Nickel plating
21	Magnet			

Quick Reference Guide

C55

C85

**C76**

CP95

C95

-X  
(Made to Order)

D-  
(Auto Switch)

Model Selection Procedures

**Series C76** Simple acting: Spring Return

**C76E Double end type - S**

**Dimensions**

Rubber Cushion/C76E **Bore** – **Stroke S** –  
 Without Magnet, Built-in Magnet

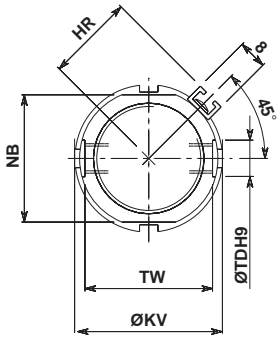

Rail mounted type (A)

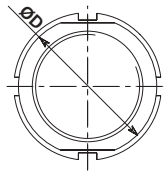

Band mounted type (B)  
 or non-magnet

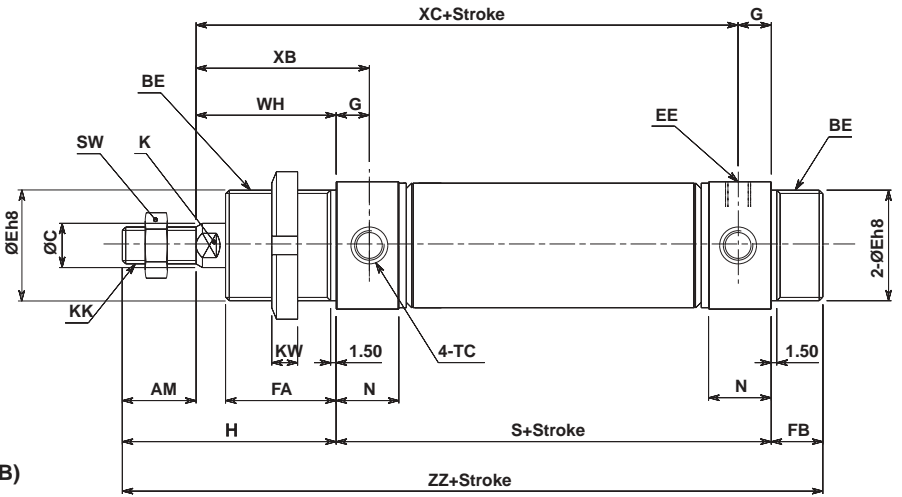

**C76KE**  
 Non-rotating, Piston rod

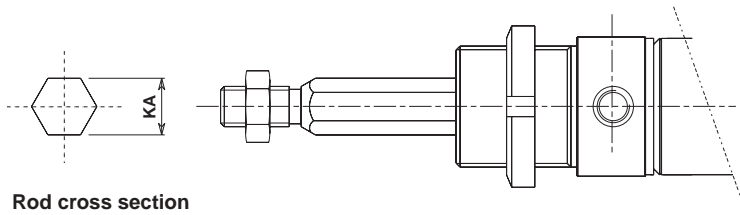

Rod cross section

Unit:mm

Bore	AM	BE	ØC	ØD	ØEH8	EE	FA	FB	G	H	HR	K	KA	KK	ØKV	KW	N	NB	SW	TC	ØTDH9	TW	WH	XB
32	20	M30x1.5	12	37.5	30	G1/8	30	14	9	58	23.8	10	12.2	M10	38	7	17	34.5	17	M8x1	10	34.5	38	47
40	24	M38x1.5	14	46.5	38	G1/8	35	16	12	69	28.3	12	14.2	M12	50	8	22	42.5	19	M10x1	12	42.5	45	57

Bore	Item Stroke	S					XC					ZZ				
		1-50	51-100	101-150	151-200	201-250	1-50	51-100	101-150	151-200	201-250	1-50	51-100	101-150	151-200	201-250
32		68 (93)	118	143	168	-	97 (122)	147	172	197	-	140 (165)	190	215	240	-
40		89 (114)	139	164	189	214	122 (147)	172	197	222	247	174 (199)	224	249	274	299

( ): in case of non-rotating

C76E Accessories

**Dimensions with mounting brackets**

Rod Foot, Rod And Head Foot: C76F32<sup>A</sup><sub>B</sub>, C76F40<sup>A</sup><sub>B</sub>

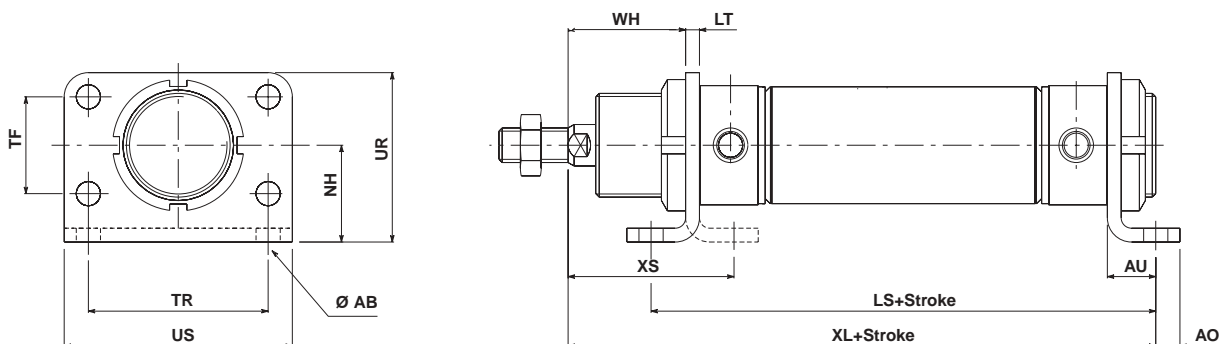

Rod Trunnion, Head Trunnion: C76T32, C76T40

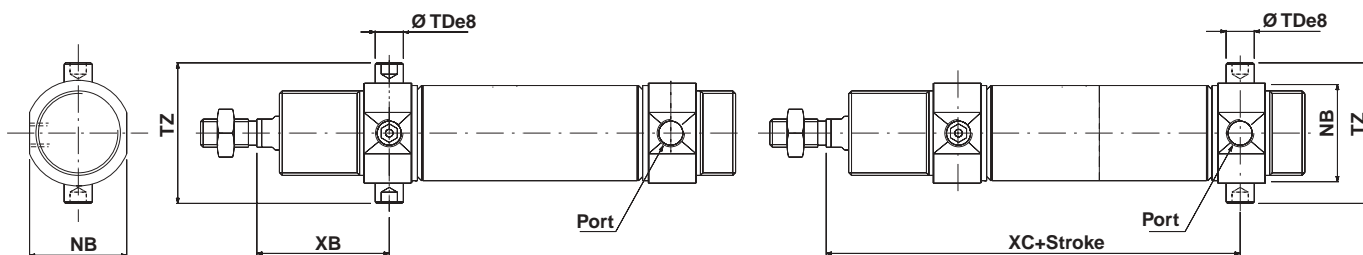

Rod clevis, Head clevis: C76C32, C75C40

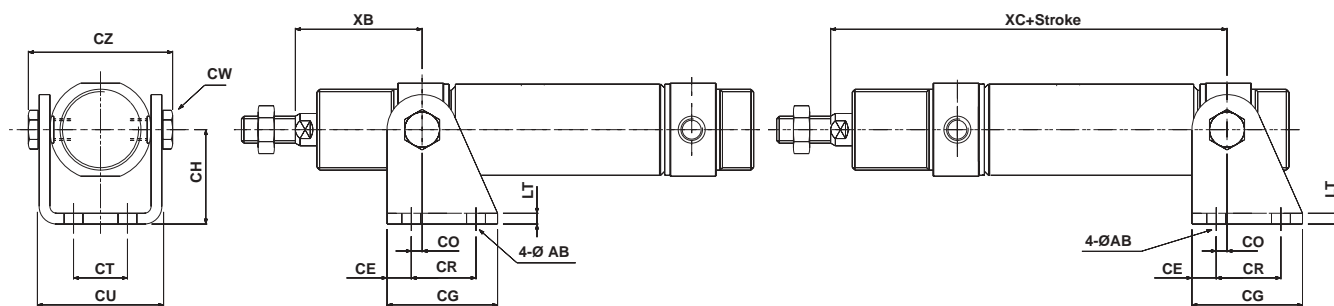

Unit:mm

Bore	Rod foot (flange)										Rod trunnion					Rod clevis											
	ØAB	AO	AU	LT	NH	TF	TR	UR	US	W	XS	NB	ØTDe8	TZ	XB	ØAB	CE	CG	CH	CO	CR	CT	CU	CW	CZ	LT	XB
32	7	7	14	4	28	28	52	49	66	34	48	34.5	10 <sup>-0.025</sup> <sub>-0.047</sub>	49.9	47	7	9	41	35	4	24	20	46.8	13	57.9	4	47
40	9	10	20	5	33	30	60	58	80	40	60	42.5	12 <sup>-0.032</sup> <sub>-0.059</sub>	62.3	57	9	12	52	40	3	30	28	58.2	17	72.3	5	57

Item Stroke	Rod foot (flange), rod and head foot										Head trunnion					Head clevis				
	LS					XL					XC					XC				
Bore	1-50	51-100	101-150	151-200	201-250	1-50	51-100	101-150	151-200	201-250	1-50	51-100	101-150	151-200	201-250	1-50	51-100	101-150	151-200	201-250
32	96	146	171	196	—	120	170	195	220	—	97	147	172	197	—	97	147	172	197	—
40	129	179	204	229	254	154	204	229	254	279	122	172	197	222	247	122	172	197	222	247

Quick Reference Guide  
C55  
C85  
C76  
CP95  
C95  
-X (Made to Order)  
D- (Auto Switch)  
Model Selection Procedures

**Series C76** Simple acting: Spring Return

**C76F** Front nose type

**Dimensions**

Rubber Cushion/C76F **Bore** – **Stroke** S – **Ø**  
 Without Magnet, Built-in Magnet

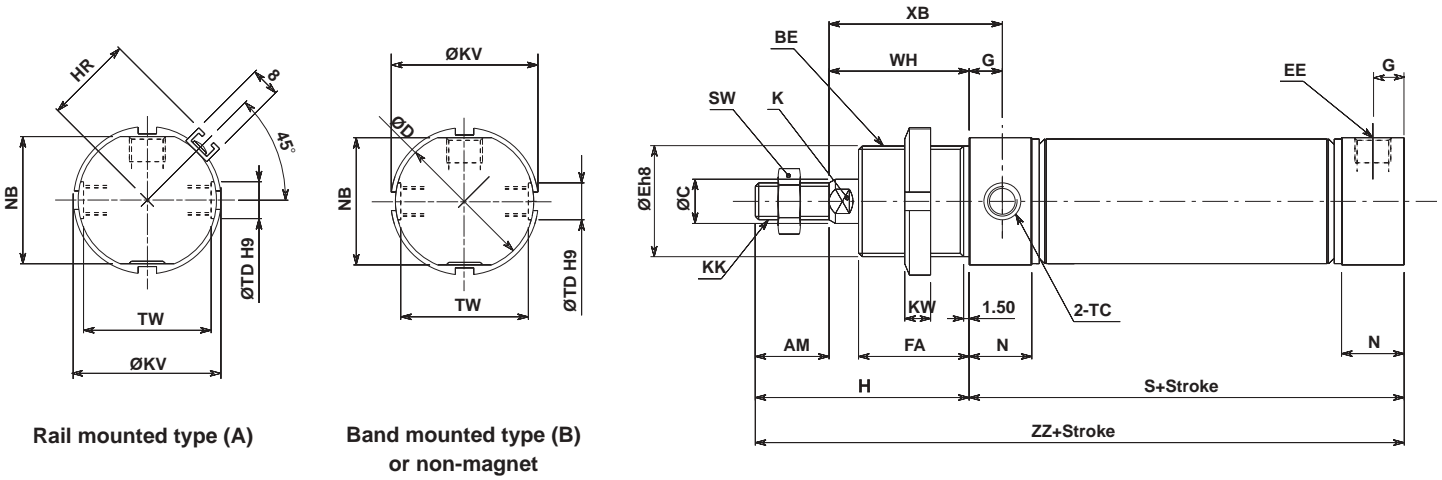

**C76KF**  
 Non-rotating, Piston rod

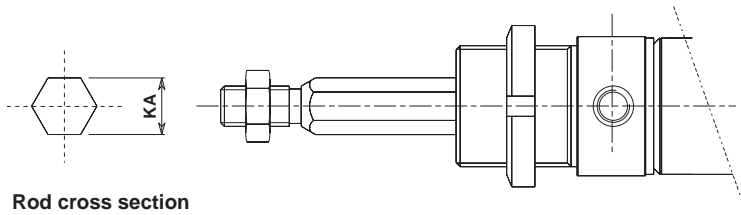

Unit:mm

Bore	AM	BE	ØC	ØD	ØEh8	EE	FA	G	H	K	KA	KK	ØKV	KW	HR	N	ØNB	SW	TC	ØTDH9	TW	WH	XB
32	20	M30x1.5	12	37.5	30	G1/8	30	9	58	10	12.2	M10	38	7	23.8	17	34.5	17	M8x1	10	34.5	38	47
40	24	M38x1.5	14	46.5	38	G1/4	35	12	69	12	14.2	M12	50	8	28.3	22	42.5	19	M10x1	12	42.5	45	57

Bore	Item Stroke	S					ZZ				
		1~50	51~100	101~150	151~200	201~250	1~50	51~100	101~150	151~200	201~250
32		68 (93)	118	143	168	—	126 (151)	176	201	226	—
40		89 (114)	139	164	189	214	158 (183)	208	233	258	283

( ) : in case of non-rotating



C76 Accessories

Dimensions with mounting brackets

Rod Foot, Rod And Head Foot: C76F32<sup>A</sup><sub>B</sub>, C76F40<sup>A</sup><sub>B</sub>

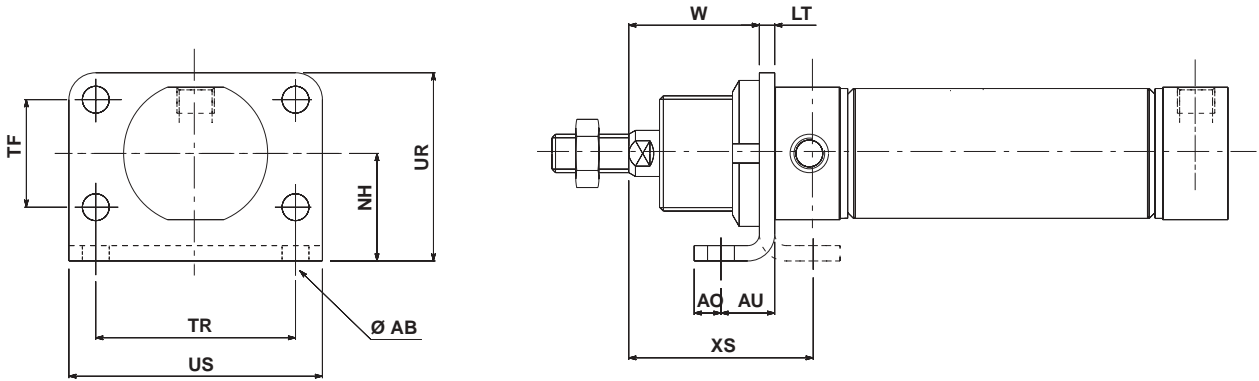

Rod Trunnion, Head Trunnion: C76T32, C76T40

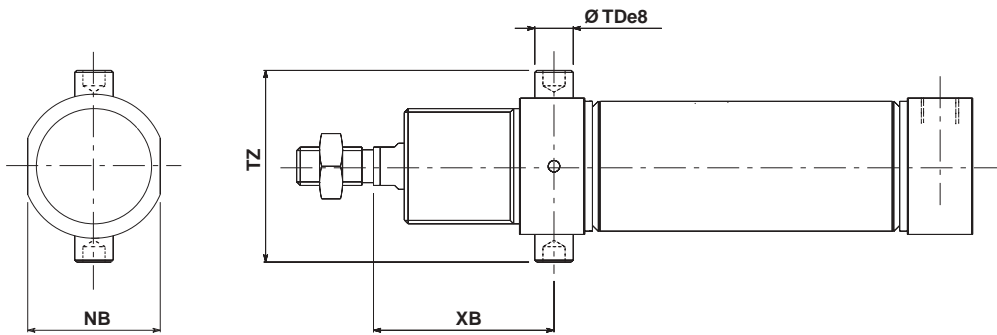

Rod clevis, Head clevis: C76C32, C75C40

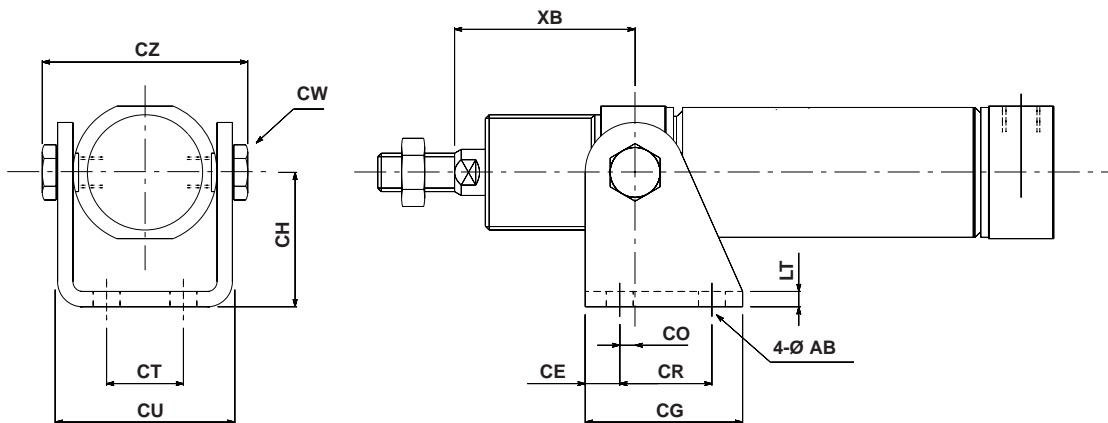

Unit:mm

Bore	Rod foot (flange)										Rod trunnion				Rod clevis												
	ØAB	AO	AU	LT	NH	TF	TR	UR	US	W	XS	NB	ØTDe8	TZ	XB	ØAB	CE	CG	CH	CO	CR	CT	CU	CW	CZ	LT	XB
32	7	7	14	4	28	28	52	49	66	34	48	34.5	10 <sup>-0.025</sup> <sub>-0.047</sub>	49.9	47	7	9	41	35	4	24	20	46.8	13	57.9	4	47
40	9	10	20	5	33	30	60	58	80	40	60	42.5	12 <sup>-0.032</sup> <sub>-0.059</sub>	62.3	57	9	12	52	40	3	30	28	58.2	17	72.3	5	57

Quick Reference Guide  
C55  
C85  
**C76**  
CP95  
C95  
-X (Made to Order)  
D- (Auto Switch)  
Model Selection Procedures

**Series C76** Simple acting: Spring Return

**C76Y Front nose in Line Type**

**Dimensions**

Rubber Cushion/C76Y **Bore** – **Stroke** – S  
 Without Magnet, Built-in Magnet

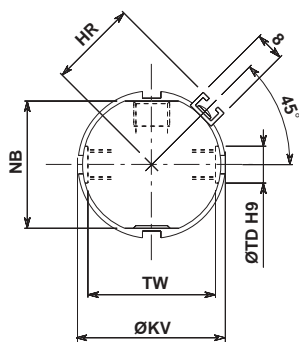

Rail mounted type (A)

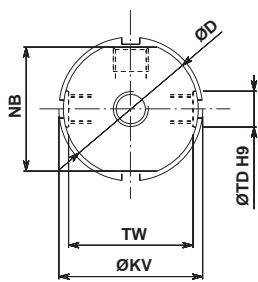

Band mounted type (B)  
or non magnetic

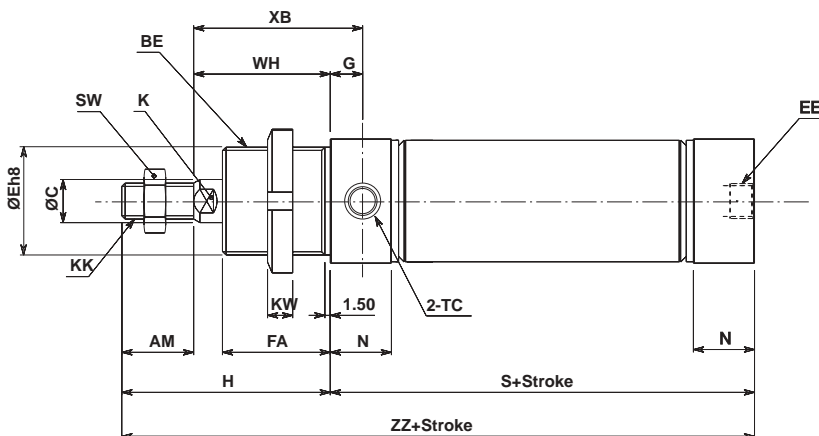

**C76KY**  
 Non-rotating, Piston rod

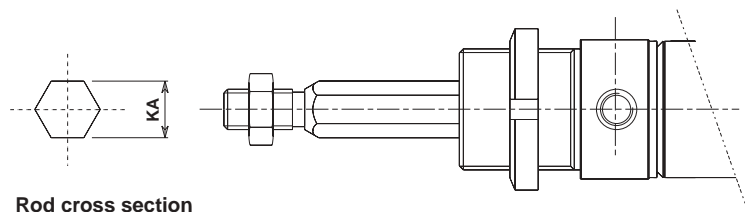

Rod cross section

Unit:mm

Bore	AM	BE	ØC	ØD	ØEh8	EE	FA	G	H	K	KA	KK	ØKV	KW	HR	N	□NB	SW	TC	ØTDH9	TW	WH	XB
32	20	M30x1.5	12	37.5	30	G1/8	30	9	58	10	12.2	M10	38	7	23.8	17	34.5	17	M8x1	10	34.5	38	47
40	24	M38x1.5	14	46.5	38	G1/4	35	12	69	12	14.2	M12	50	8	28.3	22	42.5	19	M10x1	12	42.5	45	57

Bore	Item Stroke	S					ZZ				
		1~50	51~100	101~150	151~200	201~250	1~50	51~100	101~150	151~200	201~250
32		68 (93)	118	143	168	—	126 (151)	176	201	226	—
40		89 (114)	139	164	189	214	158 (183)	208	233	258	283

( ): in case of non-rotating

**C76Y Accessories**

**Dimensions with mounting brackets**

**Rod Foot (flange): C76F32A, C76F40A**

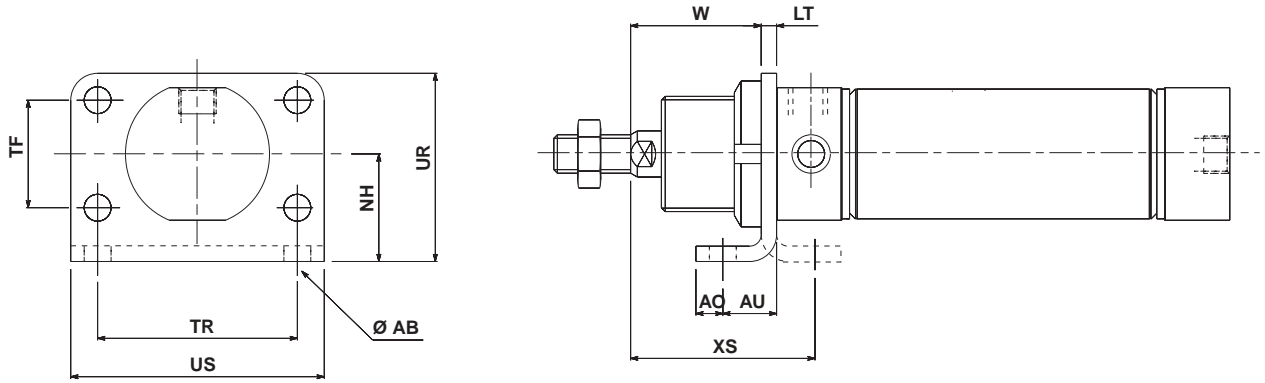

**Rod Trunnion: C76T32, C76T40**

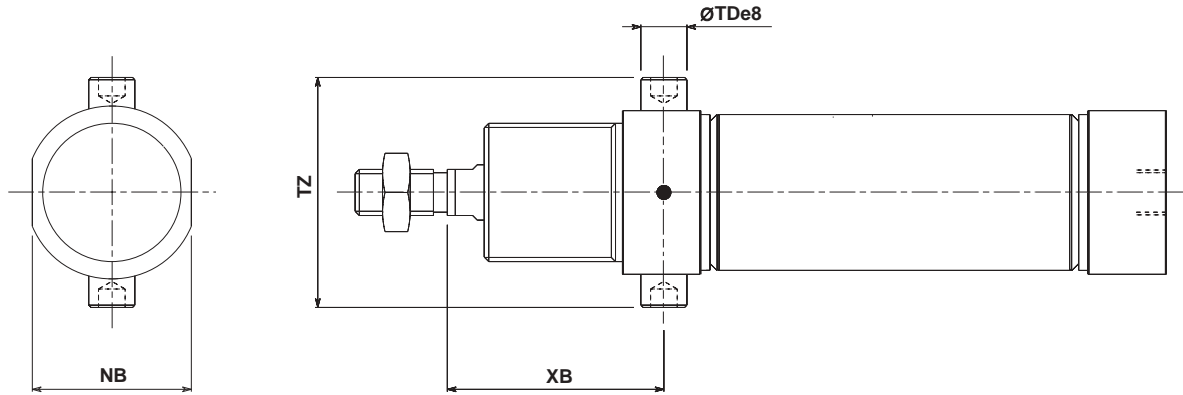

**Rod Clevis: C76C32, C76C40**

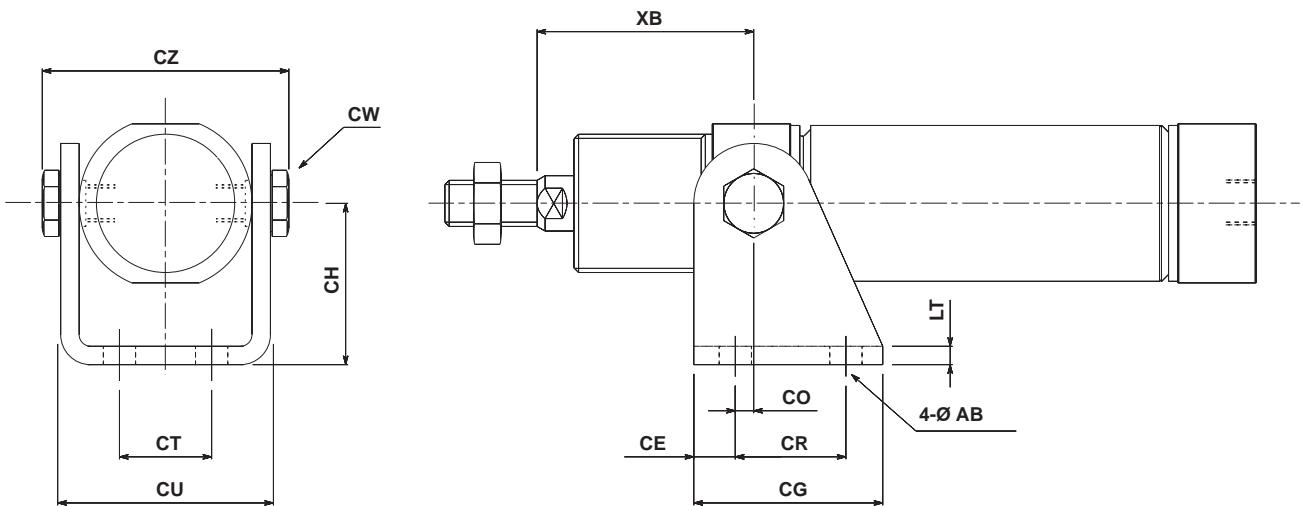

Unit:mm

Bore	Rod foot (flange)								Rod trunnion				Rod clevis														
	ØAB	AO	AU	LT	NH	TF	TR	UR	US	W	XS	NB	ØTDes	TZ	XB	ØAB	CE	CG	CH	CO	CR	CT	CU	CW	CZ	LT	XB
32	7	7	14	4	28	28	52	49	66	34	48	34.5	10 <sup>-0.025</sup> -0.047	49.9	47	7	9	41	35	4	24	20	46.8	13	57.9	4	47
40	9	10	20	5	33	30	60	58	80	40	60	62.3	12 <sup>-0.032</sup> -0.059	62.3	57	9	12	52	40	3	30	28	58.2	17	72.3	5	57

**Series C76** Simple acting: Spring Return

**C76E Double end type**

**Dimensions**

Rubber Cushion/C76E **Bore** – **Stroke** T – **Ø**  
 Without Magnet, Built-in Magnet

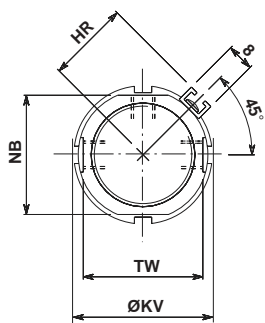

Rail mounted type (A)

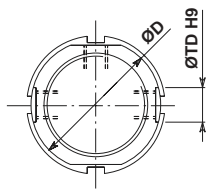

Band mounted type (B)  
or non-magnet

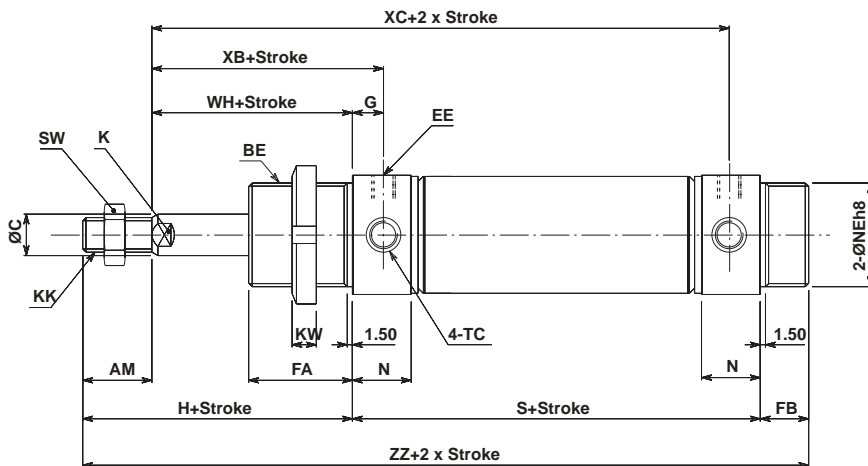

**C76KE**

Non-rotating, Piston rod

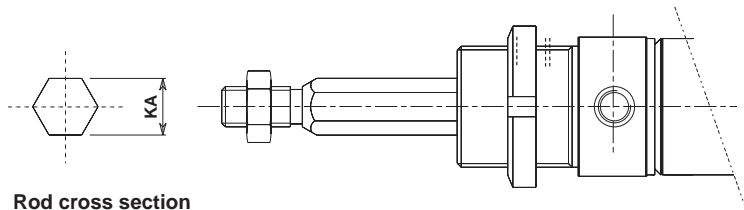

Rod cross section

Unit:mm

Bore	AM	BE	ØC	ØD	ØEh8	EE	FA	FB	G	H	K	KA	KK	ØKV	KW	HR	N	□NB	SW	TC	ØTDH9	TW	WH	XB
32	20	M30x1.5	12	37.5	30 <sup>-0</sup> <sub>-0.033</sub>	G1/8	30	14	9	58	10	12.2	M10	38	7	23.8	17	34.5	17	M8x1	10	34.5	38	47
40	24	M38x1.5	14	46.5	38 <sup>-0</sup> <sub>-0.039</sub>	G1/4	35	16	12	69	12	14.2	M12	50	8	28.3	22	42.5	19	M10x1	12	42.5	45	57

Bore	Item Stroke	S					XC					ZZ				
		1-50	51-100	101-150	151-200	201-250	1-50	51-100	101-150	151-200	201-250	1-50	51-100	101-150	151-200	201-250
32		93	118	143	168	—	122	147	172	197	-	165	190	215	240	-
40		114	139	164	189	214	147	172	197	222	247	199	224	249	274	299

**C76E Accessories**

**Dimensions with mounting brackets**

**Rod Foot (flange): C76F32A, C76F40A**

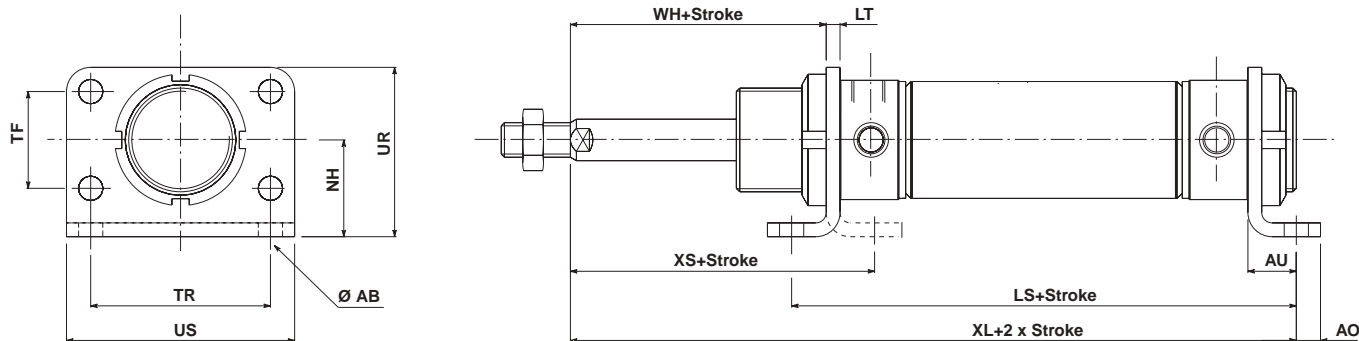

**Rod Trunnion: C76T32, C76T40**

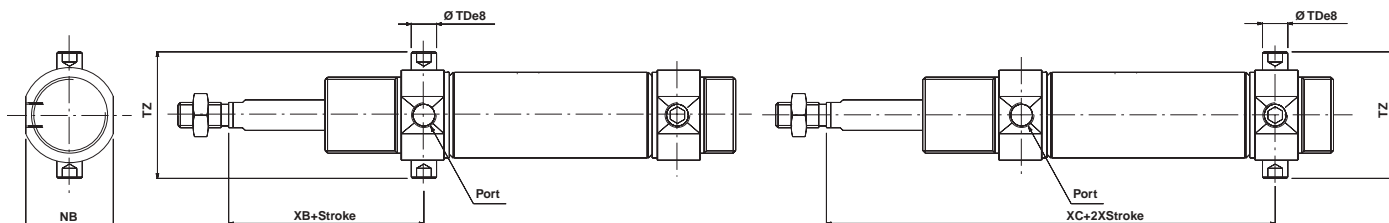

**Rod Clevis: C76C32, C76C40**

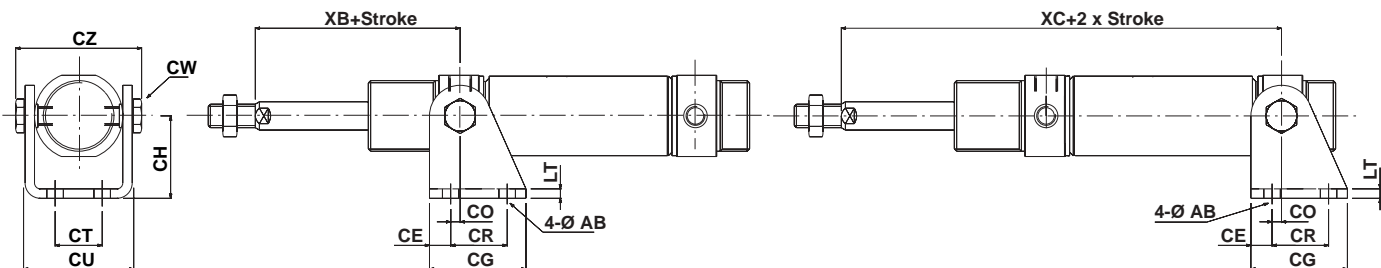

Unit:mm

Bore	Rod foot (flange), rod and head foot										Rod trunnion			Rod clevis													
	ØAB	AO	AU	LT	NH	TF	TR	UR	US	WH	XS	NB	ØTDe8	TZ	XB	ØAB	CE	CG	CH	CO	CR	CT	CU	CW	CZ	LT	XB
32	7	7	14	4	28	28	52	49	66	34	48	34.5	10 <sup>-0.025</sup> -0.047	49.9	47	7	9	41	35	4	24	20	46.8	13	57.9	4	47
40	9	10	20	5	33	30	60	58	80	40	60	42.5	12 <sup>-0.032</sup> -0.059	62.3	57	9	12	52	40	3	30	28	58.2	17	72.3	5	57

Item	Bore	Stroke	Rod foot (flange), rod and head foot										Head trunnion				
			LS					XL					XC				
			1-50	51-100	101-150	151-200	201-250	1-50	51-100	101-150	151-200	201-250	1-50	51-100	101-150	151-200	201-250
32	121	146	171	196	—	145	170	195	220	—	122	147	172	197	—		
40	154	179	204	229	254	179	204	229	254	279	147	172	197	222	247		

Item	Bore	Stroke	Head clevis				
			XC				
			1-50	51-100	101-150	151-200	201-250
32	122	147	172	197	—		
40	147	172	197	222	247		

Quick Reference Guide  
C55  
C85  
**C76**  
CP95  
C95  
-X (Made to Order)  
D- (Auto Switch)  
Model Selection Procedures

Series **C76** Simple acting: Spring extended

C76F Front nose type

Dimensions

Rubber Cushion/C76F **Bore** – **Stroke** T – **Ø**  
 Without Magnet, Built-in Magnet

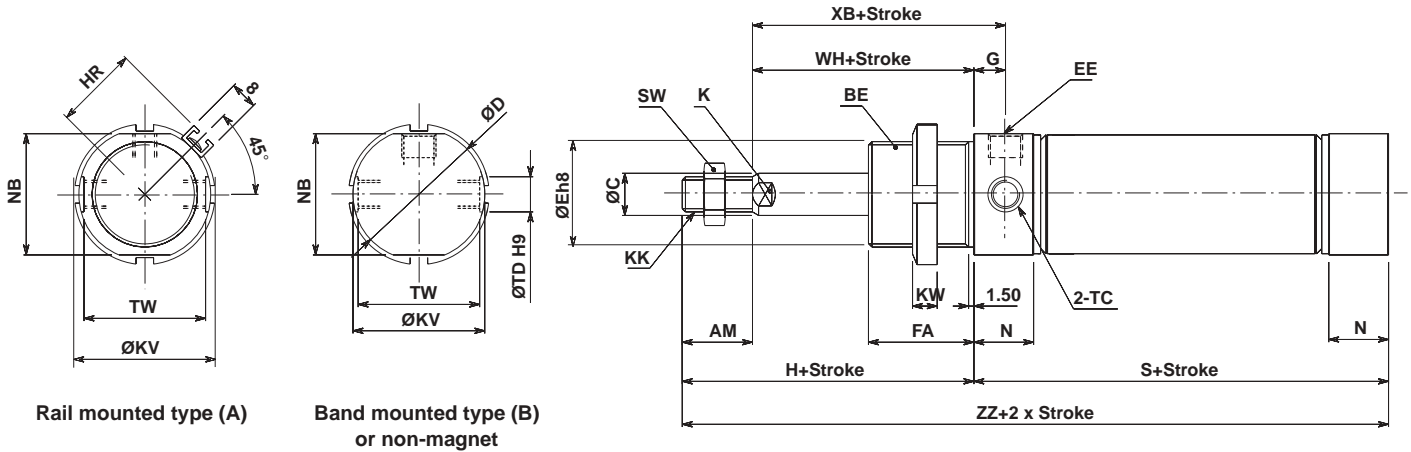

C76KF  
 Non-rotating, Piston rod

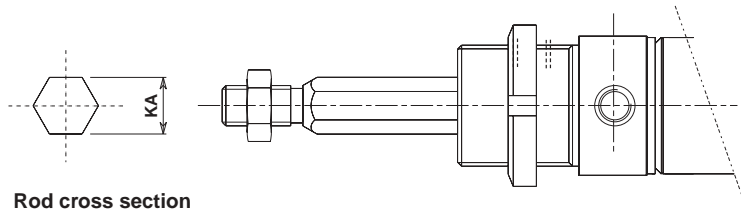

Unit:mm

Bore	AM	BE	ØC	ØD	ØEH8	EE	FA	G	H	K	KA	KK	ØKV	KW	HR	N	□NB	SW	TC	ØTDH9	TW	WH	XB
32	20	M30x1.5	12	37.5	30	G1/8	30	9	58	10	12.2	M10	38	7	23.8	17	34.5	17	M8x1	10	34.5	38	47
40	24	M38x1.5	14	46.5	38	G1/4	35	12	69	12	14.2	M12	50	8	28.3	22	42.5	19	M10x1	12	42.5	45	57

Bore	Item Stroke	S					ZZ				
		1~50	51~100	101~150	151~200	201~250	1~50	51~100	101~150	151~200	201~250
32		93	118	143	168	—	151	176	201	226	—
40		114	139	164	189	214	183	208	233	258	283

**C76 Accessories**

**Dimensions with mounting brackets**

**Rod Foot (flange): C76F32A, C76F40A**

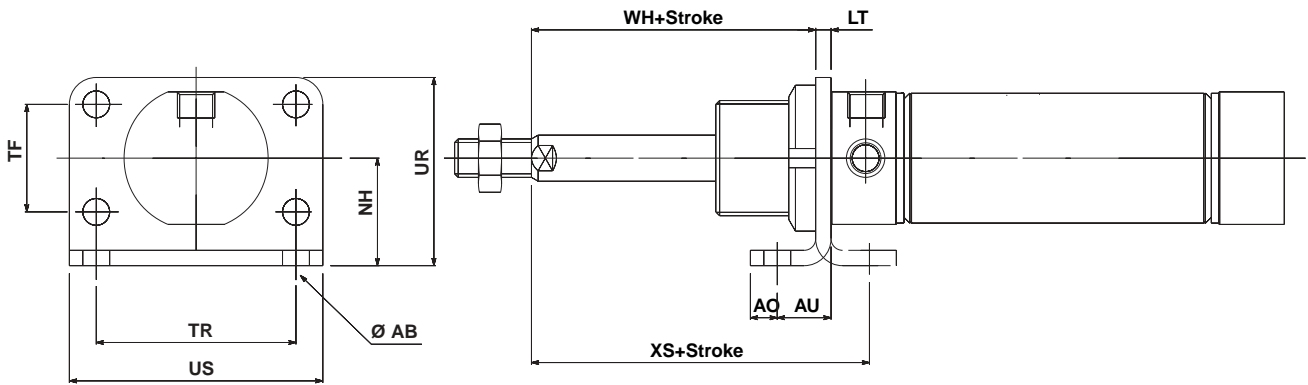

**Rod Trunnion: C76T32, C76T40**

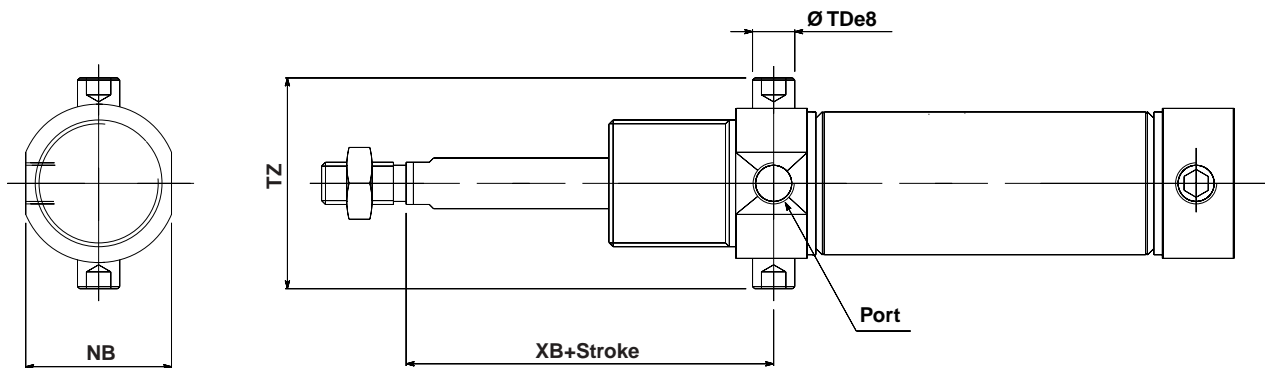

**Rod Clevis: C76C32, C76C40**

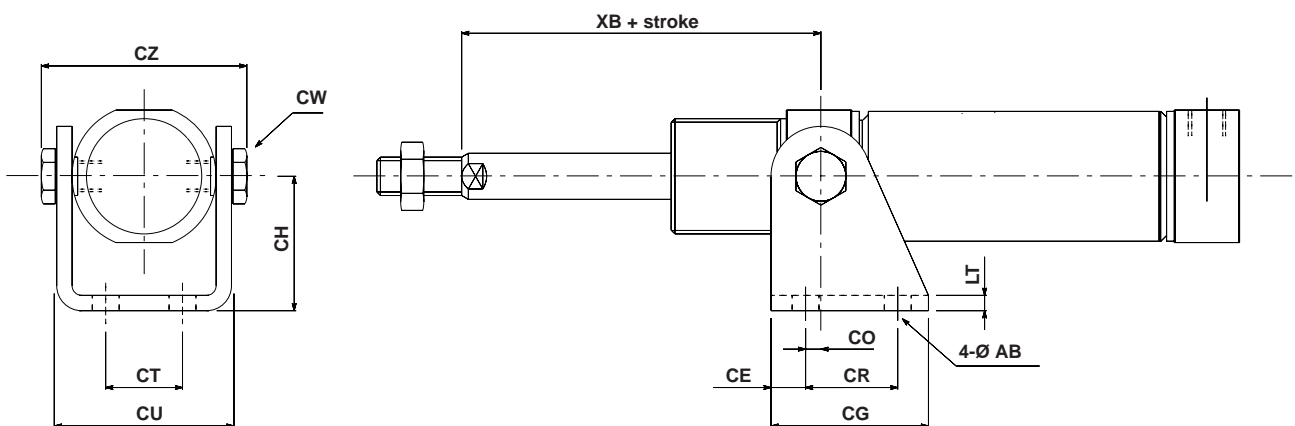

Unit:mm

Bore	Rod foot (flange)										Rod trunnion				Rod clevis												
	ØAB	AO	AU	LT	NH	TF	TR	UR	US	WH	XS	NB	ØTDes	TZ	XB	ØAB	CE	CG	CH	CO	CR	CT	CU	CW	CZ	LT	XB
32	7	7	14	4	28	28	52	49	66	34	48	34.5	10 <sup>-0.025</sup> <sub>-0.047</sub>	49.9	47	7	9	41	35	4	24	20	46.8	13	57.9	4	47
40	9	10	20	5	33	30	60	58	80	40	60	42.5	12 <sup>-0.032</sup> <sub>-0.059</sub>	62.3	57	9	12	52	40	3	30	28	58.2	17	72.3	5	57

Quick Reference Guide  
C55  
C85  
**C76**  
CP95  
C95  
-X (Made to Order)  
D- (Auto Switch)  
Model Selection Procedures

**Accessories/Dimensions**

**Single Knuckle Joint/DIN648 - DIN24335**

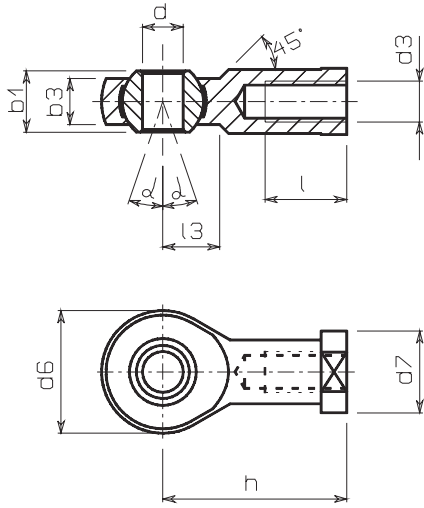

Unit: mm

Bore Size	Model	Thread d3	dH71	h	d6	b3	b1	l	d7	$\alpha^0$	l3
Ø32	KJ10DA	M10	10	43	28	10.5	14	20	19	13	14
Ø40	KJ12DA	M12	12	50	30	12	16	22	22	13	16

**Double Knuckle Joint/ISO8140 - DIN71752**

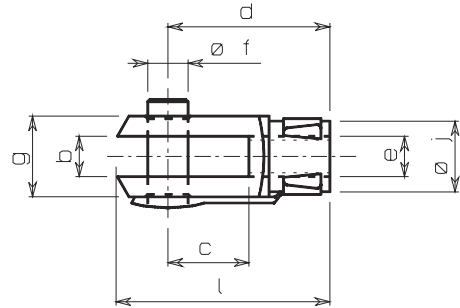

Unit: mm

Bore Size	Model	Thread e	b	d	f	g	c	j	a
Ø32	GKM10-20A	M10	10	40	10	18	20	12	20
Ø40	GKM12-24A	M12	12	48	12	23	24	15	24

**Floating-Joint/Series JA**

**JA25-40**

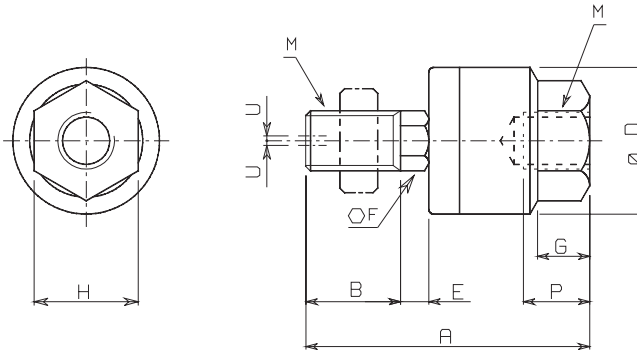

Unit: mm

Bore Size	Model	M		A	B	D	E	F	G	H	Maximum screwed depth P	Allowable eccentricity U	Max. operating tension and compression power kgf (KN)
		Nominal thread dia.	Pitch										
Ø32	JA25-10-150	10	1.5	49.5	19.5	24	5	8	8	17	9	0.5	250 (2.5)
Ø40	JA40-12-175	12	1.75	60	20	31	6	11	11	22	13	0.75	440 (4.4)



Reed Switch Setting Position (Stroke End)

(Band Mounted Type)

(Rail Mounted Type)

D-C73L  
D-C80L

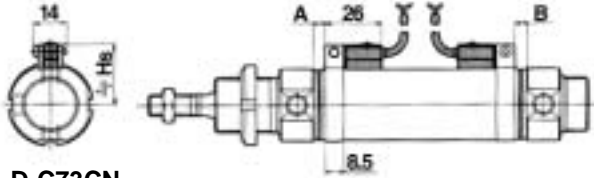

D-C73CN  
D-C80CN

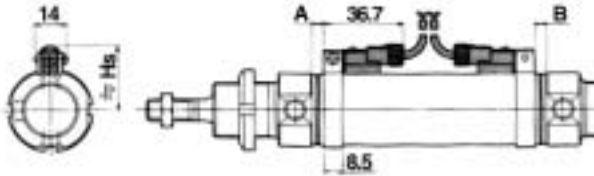

D-A73L  
D-A80L

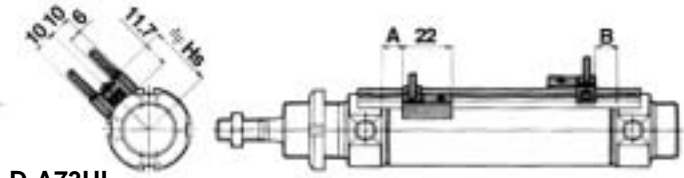

D-A73HL  
D-A80HL

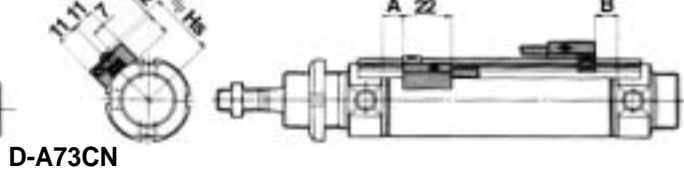

D-A73CN  
D-A80CN

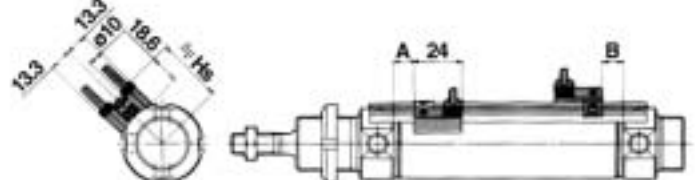

D-A79WL

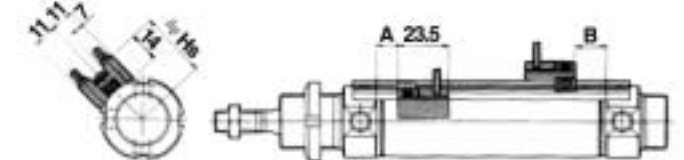

Auto Switch Mounting, Minimum Possible Cylinder Strokes

Unit:mm

Band Mounted Type

Auto switch model	No. of auto switches				1pc.
	2pcs.		npcs.		
	Different orientation	Same orientation	Different orientation	Same orientation	
D-C73L D-C80L	15	50	$15+45(\frac{n-2}{2})$ (n=2,4,...)	$50+45(n-2)$	10
D-C73CN D-C80CN	15	65	$15+50(\frac{n-2}{2})$ (n=2,4,...)	$65+50(n-2)$	10

Rail Mounted Type

Auto switch model	No. of auto switches				1pc.
	2pcs.		npcs.		
	Different orientation	Same orientation	Different orientation	Same orientation	
D-A73L, D-A80L, D-A73HL, D-A80HL, D-A73CN, D-A80CN	—	10	—	$10+35(\frac{n-2}{2})$ (n=2,4,...)	5
D-A79WL	—	15	—	$15+35(\frac{n-2}{2})$ (n=2,4,...)	10

Auto switch model	Bore size	Single acting/Spring return						Single acting/Spring extended						Hs
		A					B	A	B					
		1:50st	51:100st	101:150st	151:200st	201:250st			1:50st	51:100st	101:150st	151:200st	201:250st	
D-C73L	32	8(33)	58	83	108	—	7	8	32	57	82	107	—	28.5
D-C80L	40	13(38)	63	88	113	138	12	13	37	62	87	112	137	32.5
D-C73CN	32	8(33)	58	83	108	—	7	8	32	57	82	107	—	31
D-C80CN	40	13(38)	63	88	113	138	12	13	37	62	87	112	137	35
D-A73L	32	9(34)	59	84	109	—	1	9	33	58	83	108	—	29.3
D-A80L	40	14(39)	64	89	114	139	6	14	38	63	88	113	138	33.8
D-A73HL	32	9(34)	59	84	109	—	8	9	33	58	83	108	—	30.3
D-A80HL	40	14(39)	64	89	114	139	13	14	38	63	88	113	138	34.8
D-A73CN	32	9(34)	59	84	109	—	8	9	33	58	83	108	—	36.2
D-A80CN	40	14(39)	64	89	114	139	13	14	38	63	88	113	138	40.7
D-A79WL	32	6(31)	56	81	106	—	5	6	30	55	80	105	—	31.6
	40	11(36)	61	86	111	136	10	11	35	60	85	110	135	36.1

( ): In case of non-rotating

Series C76 Single Acting: Spring Return/ Spring Extended

Solid State Switch Setting Position (Stroke End)

(Band Mounted Type)

(Rail Mounted Type)

D-H7A1L  
D-H7A2L  
D-H7BL

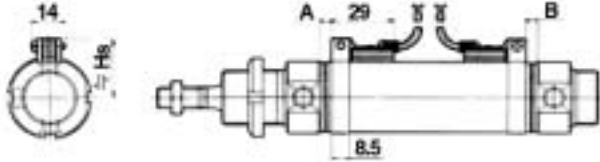

D-F79L  
D-F7PL  
D-J79L

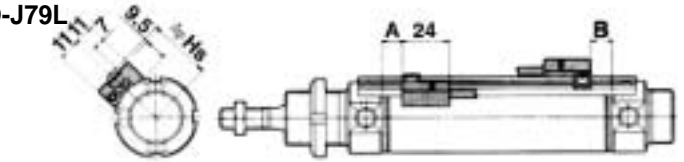

D-H7CN

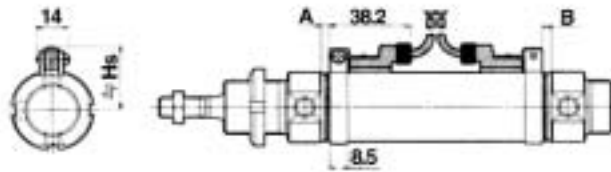

D-J79CN

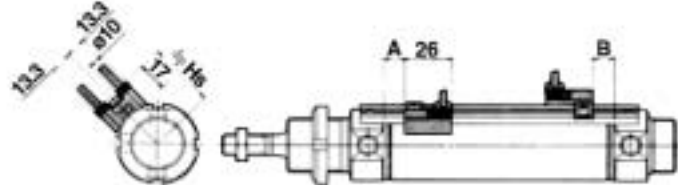

D-H7NWL  
D-H7PWL  
D-H7BWL

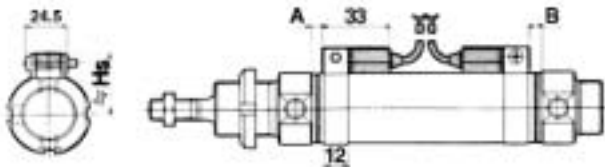

D-F79WL  
D-F7PWL  
D-J79WL

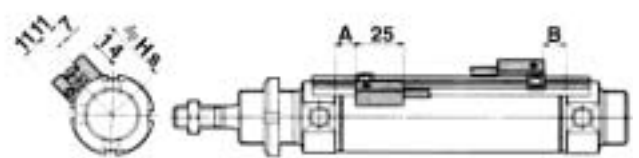

Auto Switch Mounting, Minimum Possible Cylinder Strokes

Unit:mm

Band Mounted Type

Auto switch model	No. of auto switches				1pc.
	2pcs.		npcs.		
	Different orientation	Same orientation	Different orientation	Same orientation	
D-H7A1L, D-H7A2L D-H7BL	15	50	15+45( $\frac{n-2}{2}$ ) (n=2,4,...)	50+45(n-2)	10
D-H7CN	15	65	15+50( $\frac{n-2}{2}$ ) (n=2,4,...)	65+50(n-2)	10
D-H7NWL, D-H7PWL, D-H7BWL	15	75	15+50( $\frac{n-2}{2}$ ) (n=2,4,...)	75+55(n-2)	10

Rail Mounted Type

Auto switch model	No. of auto switches				1pc.
	2pcs.		npcs.		
	Different orientation	Same orientation	Different orientation	Same orientation	
D-F79L, D-J79L, D-F7PL, D-J79CN	—	10	—	10+35( $\frac{n-2}{2}$ ) (n=2,4,...)	5
D-F79WL, D-F7PWL, D-J79WL	—	15	15+50( $\frac{n-2}{2}$ ) (n=2,4,...)	15+35( $\frac{n-2}{2}$ ) (n=2,4,...)	10

Auto switch model	Bore size	Single acting/Spring return					B	Single acting/Spring extended					Hs	
		A						A	B					
		1÷50st	51÷100st	101÷150st	151÷200st	201÷250st			1÷50st	51÷100st	101÷150st	151÷200st		201÷250st
D-H7A1L D-H7A2L D-H7BL	32	7(32)	57	82	107	—	6	7	31	56	81	106	—	28.5
	40	12(37)	62	87	112	137	11	12	36	61	86	111	136	32.5
D-H7CN	32	7(32)	57	82	107	—	6	7	31	56	81	106	—	31.5
	40	12(37)	62	87	112	137	11	12	36	61	86	111	136	35.5
D-H7NWL D-H7PWL D-H7BWL	32	5.5(30.5)	55.5(58.5)	80.5	105.5	—	4.5	5.5	29.5	54.5	79.5	104.5	—	25.5
	40	10.5(35.5)	60.5	85.5	110.5	135	9.5	10.5	34.5	59.5	84.5	109.5	134.5	29.5
D-F79L D-F7PL D-J79L	32	9(34)	59	84	109	—	8	9	33	58	83	108	—	30
	40	14(39)	64	89	114	139	13	14	38	63	88	113	138	34.5
D-J79CN	32	9(34)	59	84	109	—	8	9	33	58	83	108	—	34.6
	40	14(39)	64	89	114	139	13	14	38	63	88	113	138	39.1
D-F79WL D-F7PWL D-J79WL	32	13(38)	63	88	113	—	12	13	35	60	85	112	—	28.5
	40	18(43)	68	93	118	143	17	16	40	65	90	117	142	32.5

Double Acting, Single Rod

# Series C76

Bore size: ø32, ø40



### Symbol

Double Acting/Single Rod

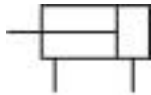

### Specifications

Bore size (mm)	32	40
Piston rod dia. (mm)	12	14
Piston rod thread	M10	M12
Ports	G1/8	G1/4
Action	Double acting/Single Rod	
Fluid	Air	
Proof pressure	1.5MPa {15bar}	
Max operating pressure	1.0MPa {10bar}	
Min operating pressure	0.05MPa {0.5bar}	
Ambient and fluid temperature	-20÷80°C (Built-in magnet type: -10÷60°C)	
Cushion	Rubber cushion	
Lubrication	None (Non lubricated)	
Piston speed	50÷1500mm/s	
Allowable kinetic energy (J)	0.65	1.2

### Construction/Part list

C ○ 76R <sup>A</sup> <sub>B</sub> 32 ~ 40

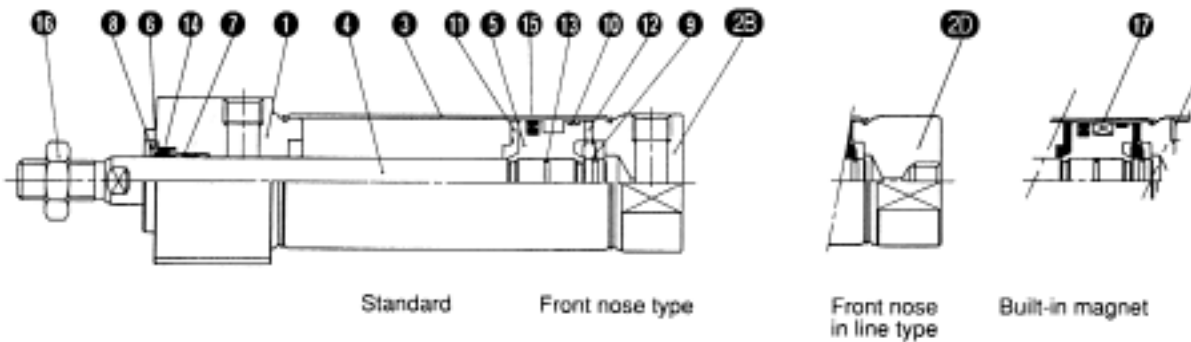

### Parts List

Item	Part name	Material	Quantity	Remarks
1	Rod cover	Aluminum alloy	1	White alumite
2B	Head cover E	Aluminum alloy	1	White alumite
2D	Head cover Y	Aluminum alloy	1	White alumite
3	Cylinder tube	Stainless steel	1	
4	Piston rod	Carbon steel	1	Hard chrome plated
5	Piston	Aluminum alloy	1	Chromate
6	Plain washer	Carbon steel	1	Nickel plating
7	Bush	Sintered bronze	1	
8	Retaining ring	Carbon steel	1	Nickel plating
9	Retaining ring	Carbon steel	1	
10	Wear ring	Phenolic resin	1	

Item	Part name	Material	Quantity	Remarks
11	Bumper A	Urethane	1	
12	Bumper B	Urethane	1	
13	Piston gasket	NBR	1	
14	Rod seal	NBR	1	
15	Piston seal	NBR	1	
16	Rod end nut	Carbon steel	1	Nickel plating
17	Magnet	Magnet	1	(switch type only)

**Series C76** Direct mounting/ double acting: single rod

**How To Order**

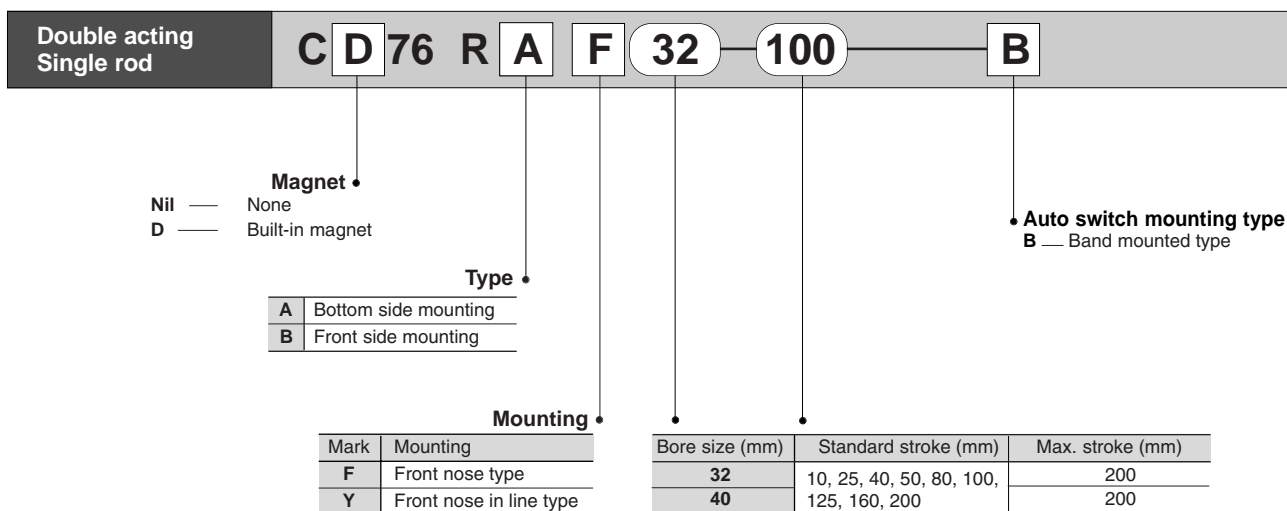

**Parts No. of Accessories**

Bore size (mm)		32	40
Accessories	Single knuckle joint	KJ10DA	KJ12DA
	Double knuckle joint	GKM10-20A	GKM12-24A
	Floating joint	JA25-10-150	JA40-12-175

Bore (mm)	Code number	Note
32	C76-32PS	Every set includes: n°1 rod packing n°1 packing retaining washer n°1 retaining ring
40	C76-40PS	

**Example of How to Order**

- In case of without auto switch, bore size: 32, stroke: 100, double acting/single rod, bottom side mounting and front nose type.  
 C76RAF32-100 1 pc. — Cylinder
- In case of with auto switch (band mounted type, 2 pcs.), bore size: 40, stroke: 100, double acting/single rod, front side mounting and front nose type.  
 CD76RBF 40-100-B 1pc. — Cylinder  
 D-C73L 2 pcs. — Auto switch  
 BM2-040 2 pcs. — Switch mounting band

**C76R Front Nose Type**

**Dimensions**

Rubber Cushion/C76 R A F **Bore** – **Stroke** – B  
Without Magnet, Built-in Magnet

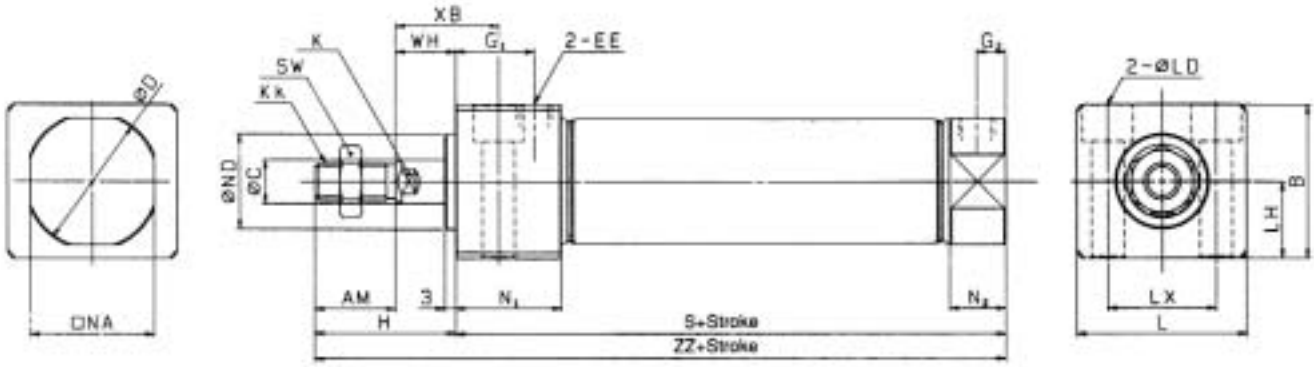

Bore	AM	B	ØC	ØD	EE	G1	G2	H	K	KK	L	ØLD	LH	LX	N1	N2	NA	ØND	S	SW	WH	XB	ZZ
32	20	42.3	12	37.5	G1/8	22	9	36	10	M10	47	Ø9, Ø14 depth of counter bore 10	21	30	29	17	34.5	26 <sup>0</sup> <sub>-0.033</sub>	80	17	16	28	116
40	24	52.3	14	46.5	G1/4	27	12	40	12	M12	58.5	Ø11, Ø17.5 depth of counter bore 12.5	26	38	38	22	42.5	32 <sup>0</sup> <sub>-0.039</sub>	105	19	16	31	145

Rubber Cushion/C76 R B F **Bore** – **Stroke** – B  
Without Magnet, Built-in Magnet

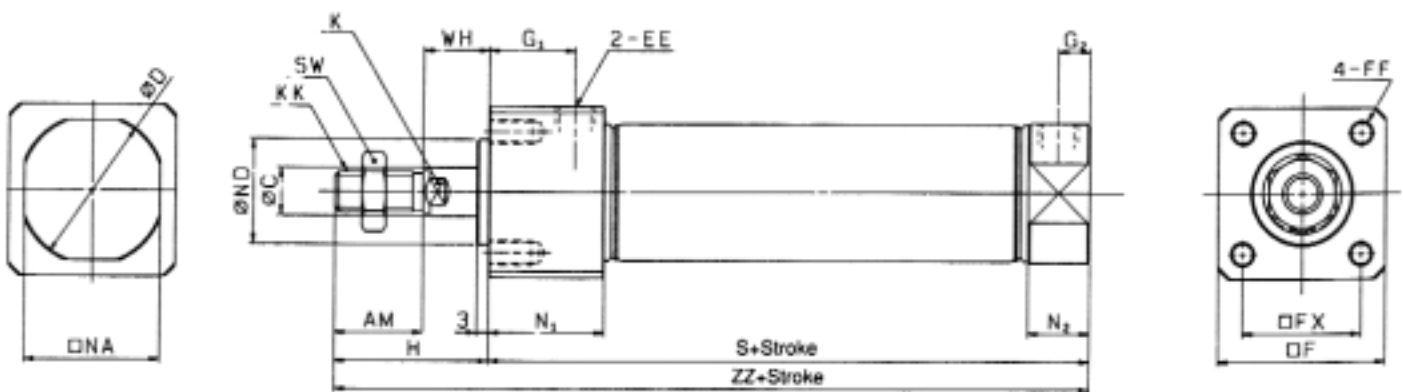

Bore	AM	ØC	ØD	EE	F	FF	FX	G1	G2	H	K	KK	N1	N2	NA	ØND	S	SW	WH	ZZ
32	20	12	37.5	G1/8	42.4	M6 Depht 11	30	22	9	36	10	M10	29	17	34.5	26 <sup>0</sup> <sub>-0.033</sub>	80	17	16	116
40	24	14	46.5	G1/4	52.4	M8 Depht 14	36	27	12	40	12	M12	38	22	42.5	32 <sup>0</sup> <sub>-0.039</sub>	105	19	16	145

Quick Reference Guide

C55

C85

**C76**

CP95

C95

-X (Made to Order)

D- (Auto Switch)

Model Selection Procedures

**Series C76** Direct mounting/ double acting: single rod

**C76R Front Nose In Line Type**

**Dimensions**

Rubber Cushion/C76 R A Y **Bore** – **Stroke** – B  
Without Magnet, Built-in Magnet

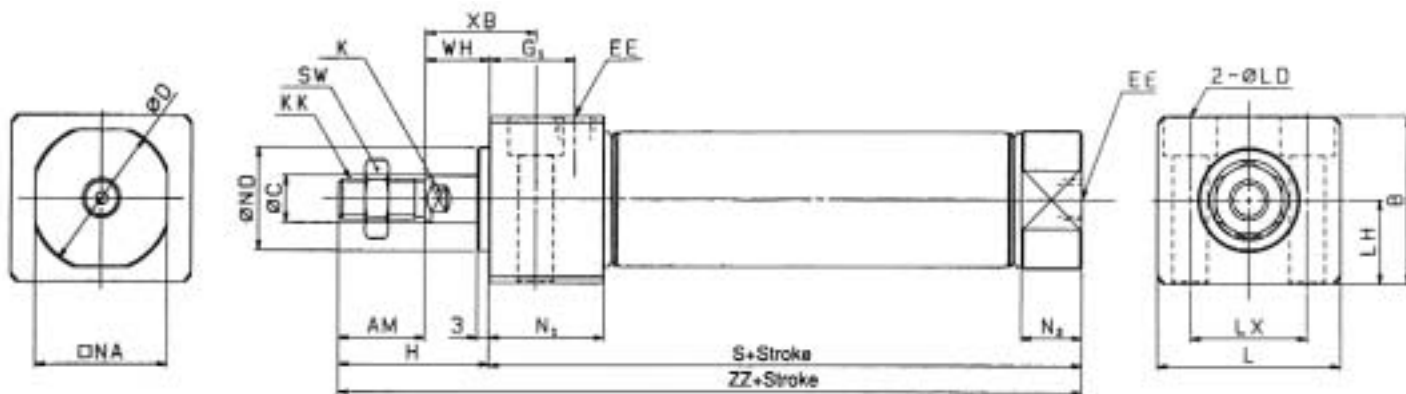

Bore	AM	B	ØC	ØD	EE	G1	H	K	KK	L	ØLD	LH	LX	N1	N2	NA	ØND	S	SW	WH	XB	ZZ
32	20	42.3	12	37.5	G1/8	22	36	10	M10	47	Ø9, Ø14 depth of counter bore 1	21	30	29	17	34.5	26 <sup>0</sup> <sub>-0.033</sub>	80	17	16	28	116
40	24	52.3	14	46.5	G1/4	27	40	12	M12	58.5	Ø11, Ø17.5 depth of counter bore 12.5	26	38	38	22	42.5	32 <sup>0</sup> <sub>-0.039</sub>	105	19	16	31	145

Rubber Cushion/C76 R B Y **Bore** – **Stroke** C – B  
Without Magnet, Built-in Magnet

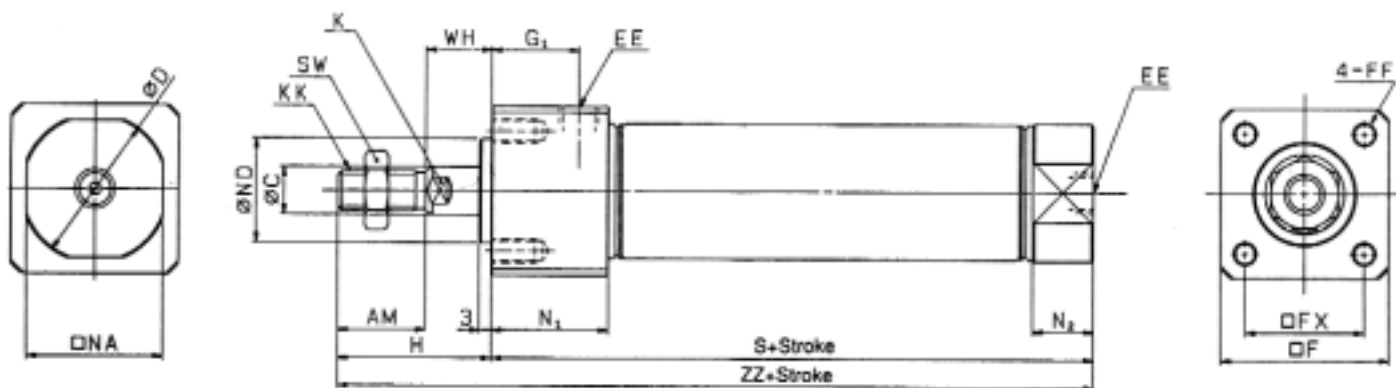

Bore	AM	ØC	ØD	EE	F	FF	FX	G1	H	K	KK	N1	N2	NA	ØND	S	SW	WH	ZZ
32	20	12	37.5	G1/8	42.4	M6 Depht 11	30	22	36	10	M10	29	17	34.5	26 <sup>0</sup> <sub>-0.033</sub>	80	17	16	116
40	24	14	46.5	G1/4	52.4	M8 Depht 14	36	27	40	12	M12	38	22	42.5	32 <sup>0</sup> <sub>-0.039</sub>	105	19	16	145

**Accessories/Dimensions**

**Single Knuckle Joint/DIN648**

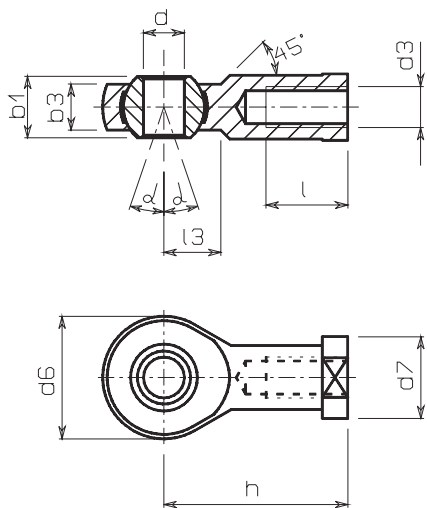

Unit: mm

Bore Size	Model	Thread d3	dH71	h	d6	b3	b1	l	d7	$\alpha^0$	l3
Ø32	KJ10DA	M10	10	43	28	10.5	14	20	19	13	14
Ø40	KJ12DA	M12	12	50	30	12	16	22	22	13	16

**Double Knuckle Joint/DIN71751**

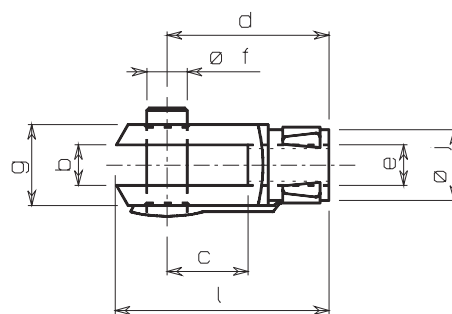

Unit: mm

Bore Size	Model	Thread e	b	d	f	g	c	j	a
Ø32	GKM10-20A	M10	10	40	10	18	20	12	20
Ø40	GKM12-24A	M12	12	48	12	23	24	15	24

**Floating-Joint/Series JA**

**JA25-40**

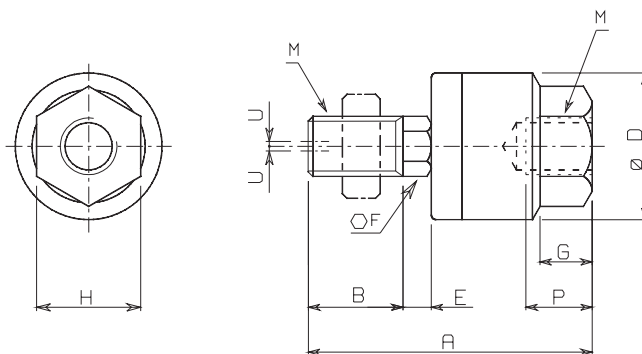

Unit: mm

Bore Size	Model	M		A	B	D	E	F	G	H	Maximum screwed depth P	Allowable eccentricity U	Max. operating tension and compression power kgf (KN)
		Nominal thread dia.	Pitch										
Ø32	JA25-10-150	10	1.5	49.5	19.5	24	5	8	8	17	9	0.5	250 (2.5)
Ø40	JA40-12-175	12	1.75	60	20	31	6	11	11	22	13	0.75	440 (4.4)

Quick Reference Guide  
C55  
C85  
**C76**  
CP95  
C95  
-X (Made to Order)  
D- (Auto Switch)  
Model Selection Procedures

**Series C76** Direct mounting/ double acting: single rod

**Reed Switch Setting Position (Stroke End)**  
(Band Mounted Type)

D-C73L  
D-C80L

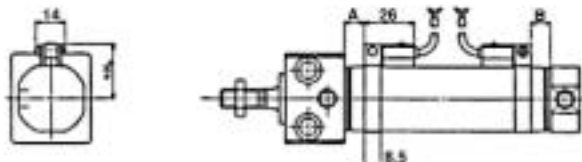

D-C73CN  
D-C80CN

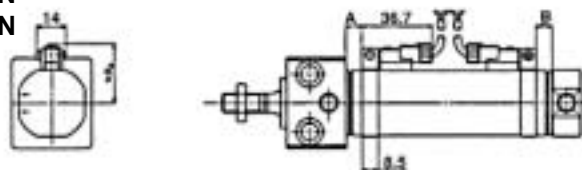

**Solid State Switch Setting Position (Stroke End)**  
(Band Mounted Type)

D-H7A1L  
D-H7A2L  
D-H7BL

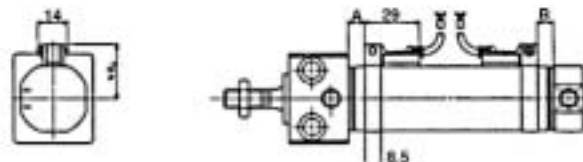

D-H7CN

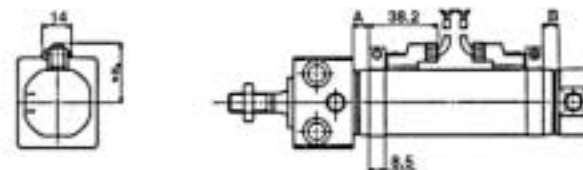

D-H7NWL  
D-H7PWL  
D-H7BWL

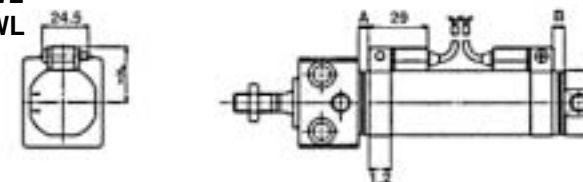

**Auto Switch Mounting, Minimum Possible Cylinder Strokes**

Unit:mm

**Band Mounted Type**

Auto switch model	No. of auto switches				1pc.
	2pcs.		npcs.		
	Different orientation	Same orientation	Different orientation	Same orientation	
D-C73L, D-C80L, D-H7A1L, D-H7A2L, D-H7BL	15	50	$15+45(\frac{n-2}{2})$ (n=2,4...)	$50+45(n-2)$	10
D-C73CN, D-C80CN, D-H7CN	15	65	$15+50(\frac{n-2}{2})$ (n=2,4...)	$65+50(n-2)$	10
D-H7NWL, D-H7PWL, D-H7BWL	15	75	$15+50(\frac{n-2}{2})$ (n=2,4...)	$75+55(n-2)$	10

Bore (mm)	Reed type						Solid state type								
	D-C73L D-C80L			D-C73CN D-C80CN			D-H7A1L D-H7A2L D-H7BL			D-H7CN			D-H7NWL D-H7PWL D-H7BWL		
	A	B	Hs	A	B	Hs	A	B	Hs	A	B	Hs	A	B	Hs
32	8	7	28.5	8	7	31	7	6	28.5	7	6	31.2	5.5	4.5	28.5
40	13	12	32.5	13	12	35	12	11	32.5	12	11	35.2	10.5	9.5	32.5



# Made to Order Common Specifications



Quick Reference  
Guide

C55

C85

C76

CP95

C95

**-X  
(Made to Order)**

D-  
(Auto Switch)

Model Selection  
Procedures

# Made to Order Common Specifications -XA0 to -XA30: Change of Rod End Shape



## 1 Change of Rod End Shape

Series C76: Change of Rod End Shape -XA0, -XA1, -XA10, -XA11

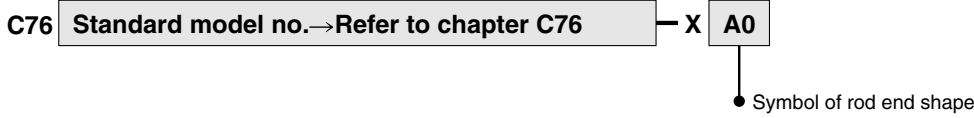

### Rod End Shape

- SMC will make appropriate arrangements if no dimensional, tolerance, or finish instructions are given in the diagram.
- Subtract 1mm from the rod diameter for the dimension marked "\*". Enter any special dimension you desire.

Applicable cylinder	Change of rod end shape/Symbol			
C76	<p>Symbol: <b>A0</b></p>	<p>Symbol: <b>A1</b></p>	<p>Symbol: <b>A10</b></p>	<p>Symbol: <b>A11</b></p>
Non-rotating rod cylinder C76K	<p>Symbol: <b>A0</b></p>	<p>Symbol: <b>A1</b></p>	<p>Symbol: <b>A10</b></p>	<p>Symbol: <b>A11</b></p>

Symbol

-XA0 to XA30

Series C76, C95, CP95: Change of Rod End Shape

-XA0 to XA30



C76 Standard model no. → Details on chapter C76 —X A1

Symbol of rod end shape ●

- SMC will make appropriate arrangements if no dimensional tolerance, or finish instructions are given in the diagram.
- Dimensions of rod diameter "D" marked "\*" is  $D \leq 25.2\text{mm}$  or  $D \geq 25.4\text{mm}$ . Enter any special dimension you desire.
- Note) A24 and A25 for series CQ2 compact cylinder are not available. Contact SMC for bore size  $\phi 12$  to  $\phi 25$ .

### Rod End Shape

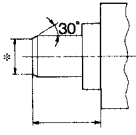
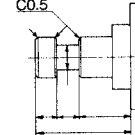
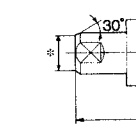
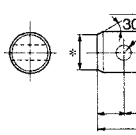
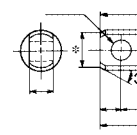
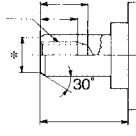
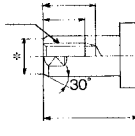
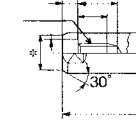
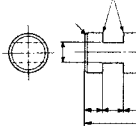
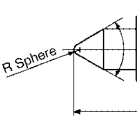
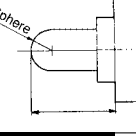
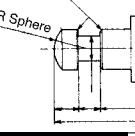
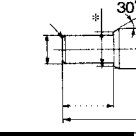
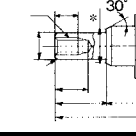
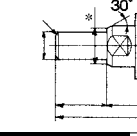
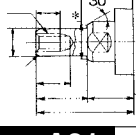
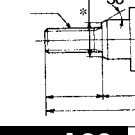
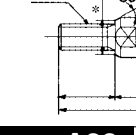
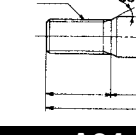
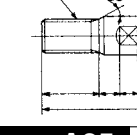
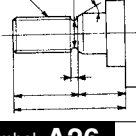
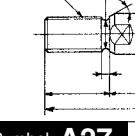
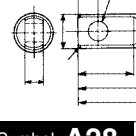
Symbol: A0 Give H, A-dimensions in case rod end shape is the same as standard shape and only H, A-dimensions are different from standard dimensions.

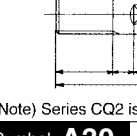
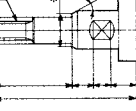
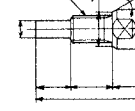
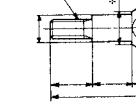
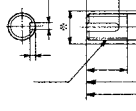
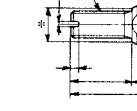
Symbol: <b>A1</b> 	Symbol: <b>A2</b> 	Symbol: <b>A3</b> 	Symbol: <b>A4</b> 	Symbol: <b>A5</b> 
Symbol: <b>A6</b> 	Symbol: <b>A7</b> 	Symbol: <b>A8</b> 	Symbol: <b>A9</b> 	Symbol: <b>A10</b> 
Symbol: <b>A11</b> 	Symbol: <b>A12</b> 	Symbol: <b>A13</b> 	Symbol: <b>A14</b> 	Symbol: <b>A15</b> 
Symbol: <b>A16</b> 	Symbol: <b>A17</b> 	Symbol: <b>A18</b> 	Symbol: <b>A19</b> 	Symbol: <b>A20</b> 
Symbol: <b>A21</b> 	Symbol: <b>A22</b> 	Symbol: <b>A23</b> 	Symbol: <b>A24</b> 	Symbol: <b>A25</b> 
Symbol: <b>A26</b> 	Symbol: <b>A27</b> 	Symbol: <b>A28</b> 	Symbol: <b>A29</b> 	Symbol: <b>A30</b> 

Note) Series CQ2 is not available.

Note) Series CQ2 is not available.

Quick Reference Guide

C55

C85

C76

CP95

C95

-X

(Made to Order)

D-

(Auto Switch)

Model Selection Procedures

# Made to Order Common Specifications -XB6: Heat Resistant Cylinder (150 C)



<b>2</b>	Heat Resistant Cylinder (150°C)	Symbol -XB6
----------	---------------------------------	----------------

**C76** Standard model no. → Details on chapter C76 —XB6  
Heat resistant cylinder

An air cylinder in which the materials of the seals and the grease have been changed so that the cylinder can be operated at high ambient temperatures of up to 150°C.

Note 1) Make sure to use without lubrication.

Note 2) Contact SMC for details on the maintenance intervals for this cylinder, which differ from those of the standard cylinder.

Note 3) It is not possible to manufacture this cylinder with an auto switch.

**⚠ Warning  
Precaution**

Be aware that smoking cigarettes, etc. after your hands have come into contact with the grease used in this cylinder can create a gas that is hazardous to humans.

### Specifications

Applicable cylinder	Air cylinder/Standard
Series	<b>C76</b>
	C76, C76W C76R, C76K
Action	Double acting single rod/double rod
Bore size (mm)	32, 40
Range of ambient temp.	-10°C to +150°C (CS1: 0°C to +150°C)
Packing material	Fluorine rubber
Grease	Heat resistant grease
Additional specifications and dimensions, refer to	Details on chapter C76

# Made to Order Common Specifications

## -XB7: Cold Resistant Cylinder



<b>3</b>	<b>Cold Resistant Cylinder</b>	<b>Symbol</b>	<b>-XB7</b>
----------	--------------------------------	---------------	-------------

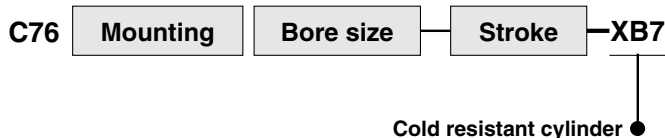

An air cylinder in which the materials of the seals and the grease have been changed so that the cylinder can be operated at ambient temperatures as low as  $-40^{\circ}\text{C}$ .

- Note 1) Make sure to use without lubrication.
- Note 2) To prevent the moisture from freezing, use dry air such as by using a heatless air dryer.
- Note 3) Contact SMC for details on the maintenance intervals for this cylinder, which differ from those of the standard cylinder.
- Note 4) It is not possible to manufacture this cylinder with an auto switch.

### Specifications

Applicable cylinder	Air cylinder/Standard	
Series	<b>C76</b>	<b>C76W</b>
Action		
Bore size (mm)	C76 (32, 40)	
Ambient temp.	$-40^{\circ}\text{C}$ to $+70^{\circ}\text{C}$	
Material	Packing, Bumper - Low nitrile rubber Wearing-Resin	
Grease	Fluorine resin grease	
Auto switch	Unavailable for mounting	
Mounting	Basic Foot Flange Trunnion Clevis	Basic Foot Flange Trunnion
Dimensions, refer to	Details on chapter C76	Details on chapter C□W
Additional specifications, refer to	Details on chapter C76	Details on chapter C□W

- Quick Reference Guide
- C55
- C85
- C76
- CP95
- C95
- X (Made to Order)
- D- (Auto Switch)
- Model Selection Procedures

# Made to Order Common Specifications -XB9: Low Speed Cylinder



<b>4</b>	Low Speed Cylinder	Symbol	-XB9
----------	--------------------	--------	------

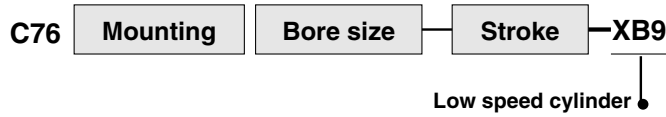

\*Operates smoothly without sticking or slipping even at low speeds of 10 to 50mm/s.  
Note 1) Do not lubricate this cylinder.

## Specifications

Applicable cylinder	Air cylinder/Standard
Series	<b>C76</b>
Action	Double acting single rod
Bore size	C76: (32, 40)
Piston speed	10 to 50mm/s
Cushion	Rubber bumper
Auto switch	Available for mounting
Mounting	Basic, Foot Flange Trunnion Clevis
Dimensions, refer to	Details on chapter C76
Additional specifications, refer to	Details on chapter C76

### **Warning** **Precaution**

Be aware that smoking cigarettes, etc. after your hands have come into contact with the grease used in this cylinder can create a gas that is hazardous to humans.