

Air Cylinder Short Type

New

Compact with a new construction!
New release with full functions

Minimised with shorter total length!

Space saving; bringing reduced equipment size.

Up to

24%
lighter

Up to

51 mm shorter

129 mm

37 mm shorter

NEW CG3

Female thread

NEW CG3

Male thread

Conventional model **CG1**

Male thread

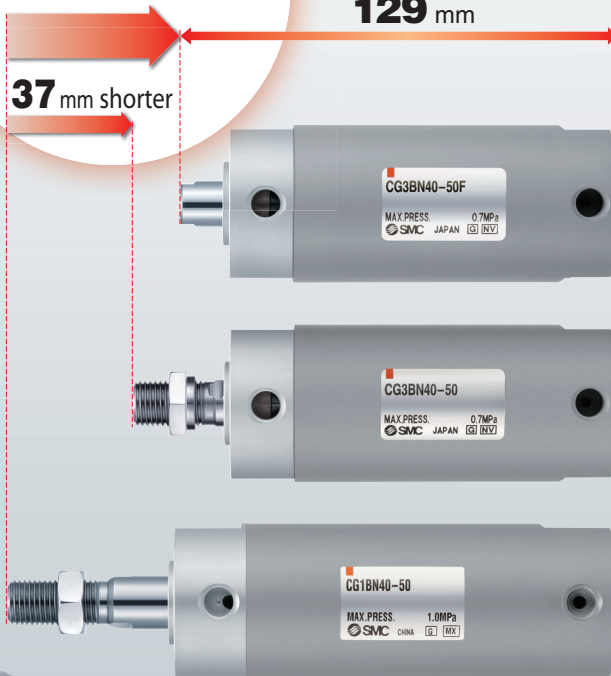

CG3BN40-50 □ stroke



Series **CG3**



Series CG3

Female rod end available as standard

Applications expanded by making it possible to select either male or female thread within the standard model.

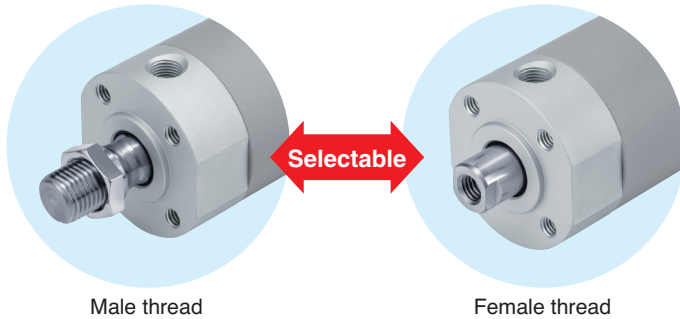

Male thread

Female thread

2-colour indication solid state auto switch mountable

Possible to confirm whether the position is appropriate at a glance.
Increases effectiveness of adjustment time.



A **green** light lights up at the optimum operating range.

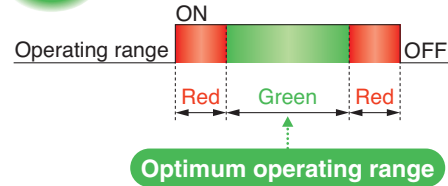

Total length minimised

- The new structure has reduced the total length.
- Up to 37 mm shorter than CG1 series, making the product more compact.
- Integrated structure of head cover and tube

Comparison of the total length with CG1 series

Bore size (mm)	Shortened by
20	27 mm
25	26 mm
32	26 mm
40	37 mm
50	29 mm
63	29 mm
80	31 mm
100	30 mm



* Compared with the basic type with male thread

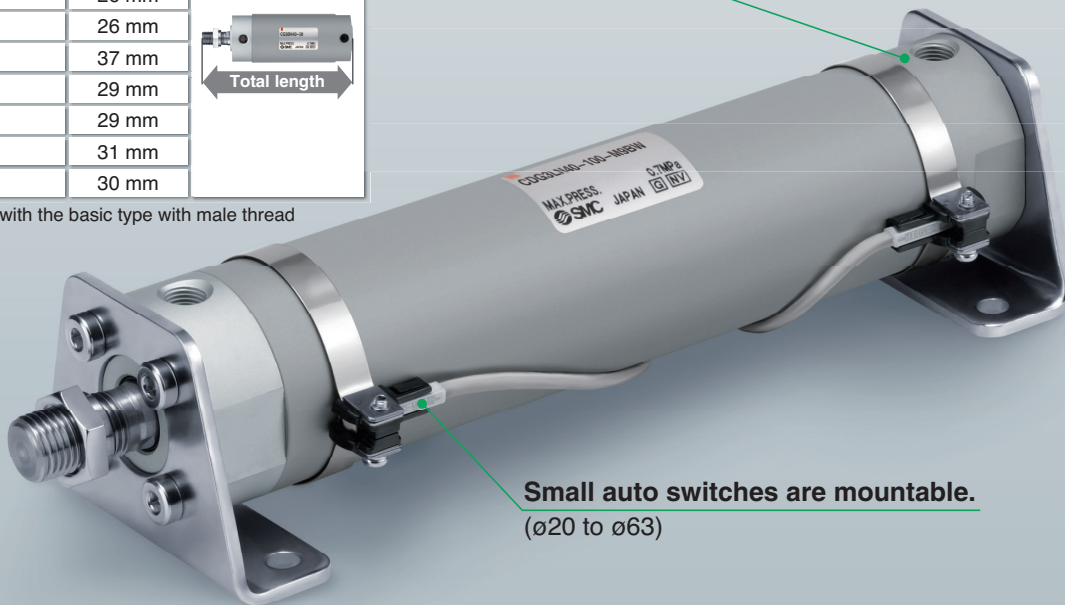

Small auto switches are mountable.
($\varnothing 20$ to $\varnothing 63$)

Series Variations

Series	Bore size (mm)	Standard stroke (mm)	Action	Rod	Mounting	Built-in magnet for auto switch	Rubber bumper	Auto switch
CG3	20	25 to 200	Double acting	Single rod	Basic, Foot, Flange, Clevis	●	●	D-M9□(W), D-A90
	25 to 63	25 to 300						
	80, 100							D-G5□(W), D-K59(W), D-B64

* For the trunnion type, please contact SMC sales representatives.

**Air Cylinder Short Type
Standard: Double Acting, Single Rod**

Series CG3

ø20, ø25, ø32, ø40, ø50, ø63, ø80, ø100

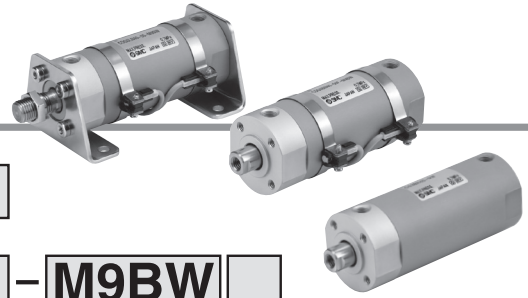

How to Order

CG3

L N 25 - 100

With auto switch

CDG3 L N 25 - 100 - M9BW

With auto switch (Built-in magnet)

Mounting

B	Basic
L	Foot
F	Rod flange
G	Head flange
D	Clevis

* Mounting brackets are shipped together, (but not assembled).

Cushion

N	Rubber bumper
---	---------------

Bore size

20	20 mm	50	50 mm
25	25 mm	63	63 mm
32	32 mm	80	80 mm
40	40 mm	100	100 mm

• Rod end thread

—	Male thread
F	Female thread
G	Long male rod end*

* G: Same rod end dimensions (A, AL, H) as CG1 series.

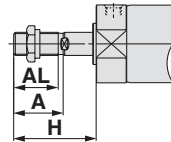

• Number of auto switches

—	2 pcs.
S	1 pc.
n	"n" pcs.

• Auto switch

—	Without auto switch
---	---------------------

* For applicable auto switches, refer to the below table.

• Cylinder stroke (mm)
Refer to the next page for standard strokes.

Built-in Magnet Cylinder Model

If a built-in magnet cylinder without an auto switch is required, there is no need to enter the symbol for the auto switch. (Example) CDG3FN32-100

Applicable Auto Switches/Refer to pages 1263 to 1371 in Best Pneumatics No. 2 for further information on auto switches.

Type	Special function	Electrical entry	Indicator/light	Wiring (Output)	Load voltage		Auto switch model		Lead wire length (m)					Pre-wired connector	Applicable load								
					DC	AC	Applicable bore size		0.5 (—)	1 (M)	3 (L)	5 (Z)	None (N)		IC circuit	Relay, PLC							
Solid state auto switch	—	Grommet	Yes	3-wire (NPN)	5 V, 12 V	—	—	M9N	●	●	●	○	○	○			○	IC circuit					
				3-wire (PNP)				G59	●	●	●	○	○										
		—		G5P	●	—	●	○	○	○													
		2-wire		12 V	—	●	●	●	○	○	○												
	Diagnostic indication (2-colour indication)	Grommet	Yes	3-wire (NPN)	24 V	5 V, 12 V	—	—	M9B	●	●	●	○	○	○	○	IC circuit						
				3-wire (PNP)					H7C	●	●	●	●	○				○					
		—	K59	●	—	●	○	○	○	○													
		2-wire	12 V	—	●	●	●	○	○	○													
		Water resistant (2-colour indication)	Grommet	Yes	3-wire (NPN)	24 V	5 V, 12 V	—	—	M9NW	●	●	●	○	○	○		○					
		3-wire (PNP)			M9PW					●	●	●	○	○	○								
—	Grommet	Yes	2-wire	24 V	12 V	—	—	M9BW	●	●	●	○	○	○	○								
With diagnostic output (2-colour indication)			—					K59W	●	—	●	○	○			○							
Reed auto switch	—	Grommet	Yes	3-wire (NPN equivalent)	24 V	12 V	—	—	A96	●	—	●	—	—	—	IC circuit							
				2-wire					100 V	A93	—	●	—	●	●	—	—	—	IC circuit				
									100 V or less	A90	—	●	—	●	—	—	—	—	IC circuit				
									100 V, 200 V	B54	—	●	—	●	●	—	—	—	—				
									200 V or less	B64	—	●	—	●	—	—	—						
		Connector		Yes	No	2-wire	24 V	12 V	—	—	—	C73C	—	●	—	●	●	—	IC circuit				
												24 V or less	C80C	—	●	—	●	●		●	—		
														—	B59W	—	●	—		●	—	—	—
																—	—	—		—	—	—	
																							—
Grommet	Yes	No	2-wire	24 V	12 V	—	—	—	—	—	—	—	—										

* Lead wire length symbols: 0.5 m — (Example) M9NW
 1 m M (Example) M9NWM
 3 m L (Example) M9NWL
 5 m Z (Example) M9NWZ
 None N (Example) H7CN

* Solid state auto switches marked with "○" are produced upon receipt of order.
 * The D-G5□/K5□/B5□/B6□ types cannot be mounted on the bore size ø40.
 * The D-A9□V/M9□V/M9□WV types and the D-M9□A(V)L type cannot be mounted.

* Since there are other applicable auto switches than listed above, refer to page 12 for details.
 * For details about auto switches with pre-wired connector, refer to pages 1328 and 1329 in Best Pneumatics No. 2.
 * The D-A9□/M9□/M9□W type auto switches are shipped together, (but not assembled). (However, auto switch mounting brackets are assembled when being shipped.)
 * Water resistant type auto switch can be mounted to the models with the above mentioned part numbers, but this does not guarantee the water resistance of the cylinder. A water resistant type cylinder is recommended for use in an environment which requires water resistance.
 * For other applicable auto switches, please contact SMC.

JIS Symbol

Double acting

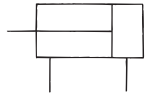

Refer to pages 9 to 12 for cylinders with auto switches.

- Auto switch proper mounting position (detection at stroke end) and its mounting height
- Minimum stroke for auto switch mounting
- Operating range
- Auto switch mounting brackets/Part no.
- Cylinder mounting bracket, By stroke/Auto switch mounting surfaces

Warning

1. Operate the cylinder within the specified cylinder speed, kinetic energy and lateral load at the rod end.

Otherwise, cylinder and seal damage may occur.

2. The allowable kinetic energy is different between the cylinders with male rod end and with female rod end due to the different thread sizes. Refer to page 4.

3. When the cylinder is used as mounted with a single side fixed or free (basic type, flange type), be careful not to apply vibration or impact to the cylinder body. A bending moment will be applied to the cylinder due to the vibration generated at the stroke end, and the cylinder may be damaged. In such a case, mount a bracket to reduce the vibration of the cylinder or use the cylinder at a piston speed low enough to prevent the cylinder from vibrating at the stroke end.

Furthermore, when the cylinder is moved or mounted horizontally and with a single side fixed, use a bracket to fix the cylinder.

4. When female rod end is used, use a washer, etc. to prevent the contact part at the rod end from being deformed depending on the material of the work piece.

Caution

1. Do not use the air cylinder as an air-hydro cylinder.

This will result in oil leakage and damage the product.

2. Use a thin wrench when tightening the piston rod.

3. Check the mounting direction of the rod end nut (for male thread). Refer to Mounting Procedure on page 3 for details.

4. There are some changes in the dimensions and the specifications of this model from the conventional model. Please check them when replacing from the conventional model. Check the operating conditions and interference with workpieces before use.

Specifications

Bore size (mm)		20	25	32	40	50	63	80	100
Action		Double acting, Single rod							
Lubrication		Not required (Non-lube)							
Fluid		Air							
Proof pressure		1.0 MPa							
Maximum operating pressure		0.7 MPa							
Minimum operating pressure		0.05 MPa							
Ambient and fluid temperature		Without auto switch: -10 to 70°C (No freezing)							
		With auto switch: -10 to 60°C (No freezing)							
Piston speed		50 to 1000 mm/s						30 to 700 mm/s	
Stroke length tolerance		20: Up to 200 ^{st+1.4} ₀ mm						Up to 300 ^{st+1.4} ₀ mm	
		25 to 63: 300 ^{st+1.4} ₀ mm							
Cushion		Rubber bumper							
Mounting		Basic, Foot, Rod flange, Head flange, Clevis (Used for changing the port location by 90°)							
Allowable kinetic energy	Male rod end	0.2 J	0.29 J	0.46 J	0.84 J	1.4 J	2.38 J	4.13 J	6.93 J
	Female rod end	0.11 J	0.18 J	0.29 J	0.52 J	0.91 J	1.54 J	2.71 J	4.54 J

* Operate the cylinder within the allowable kinetic energy. Refer to page 4 for details.

Standard Strokes

Bore size (mm)	Standard stroke (mm) ^{Note)}
20	25, 50, 75, 100, 125, 150, 200
25	25, 50, 75, 100, 125, 150, 200, 250, 300
32	
40	
50	
63	
80	
100	

Note) Manufacture of intermediate strokes in 1 mm intervals is possible. (Spacers are not used.)

Accessories

Mounting		Basic	Foot	Rod flange	Head flange	Clevis
Standard	Rod end nut (male thread)	●	●	●	●	●
	Clevis pin	—	—	—	—	●
Option	Single knuckle joint	●	●	●	●	●
	Double knuckle joint (with pin)*	●	●	●	●	●
	Pivoting bracket	—	—	—	—	●

* A double knuckle joint pin and retaining rings are shipped together.

Mounting Brackets/Part No.

Mounting bracket	Order qty.	Bore size (mm)								Contents
		20	25	32	40	50	63	80	100	
Foot	^{Note)} 2	CG-L020	CG-L025	CG-L032	CG-L040	CG-L050	CG-L063	CG-L080	CG-L100	2 feet, 8 mounting bolts
Flange	1	CG-F020	CG-F025	CG-F032	CG-F040	CG-F050	CG-F063	CG-F080	CG-F100	1 flange, 4 mounting bolts
Clevis	1	CG-D020	CG-D025	CG-D032	CG-D040	CG-D050	CG-D063	CG-D080	CG-D100	1 clevis, 4 mounting bolts, 1 clevis pin, 2 retaining rings
Pivoting bracket	1	CG-020-24A	CG-025-24A	CG-032-24A	CG-040-24A	CG-050-24A	CG-063-24A	CG-080-24A	CG-100-24A	1 pivoting bracket

Note) Order 2 feet per cylinder.

Theoretical Output

Unit: N

Bore size D (mm)	Rod size d (mm)	Operating direction	Piston area (mm ²)	Operating pressure (MPa)					
				0.2	0.3	0.4	0.5	0.6	0.7
20	8	OUT	314	62.8	94.2	125.6	157	188.4	219.8
		IN	264	52.8	79.2	105.6	132	158.4	184.8
25	10	OUT	491	98.2	147.3	196.4	245.5	294.6	343.7
		IN	412	82.4	123.6	164.8	206	247.2	288.4
32	12	OUT	804	160.8	241.2	321.6	402	482.4	562.8
		IN	691	138.2	207.3	276.4	345.5	414.6	483.7
40	14	OUT	1257	251.4	377.1	502.8	628.5	754.2	879.9
		IN	1103	220.6	330.9	441.2	551.5	661.8	772.1
50	18	OUT	1964	392.8	589.2	785.6	982	1178.4	1374.8
		IN	1709	341.8	512.7	683.6	854.5	1025.4	1196.3
63	18	OUT	3117	623.4	935.1	1246.8	1558.5	1870.2	2181.9
		IN	2863	572.6	858.9	1145.2	1431.5	1717.8	2004.1
80	22	OUT	5027	1005.4	1508.1	2010.8	2513.5	3016.2	3518.9
		IN	4646	929.2	1393.8	1858.4	2323	2787.6	3252.2
100	26	OUT	7854	1570.8	2356.2	3141.6	3927	4712.4	5497.8
		IN	7323	1464.6	2196.9	2929.2	3661.5	4393.8	5126.1

Weights

(kg)

Bore size (mm)		20	25	32	40	50	63	80	100
Basic weight	Basic	0.09	0.14	0.20	0.32	0.66	0.92	1.75	2.74
	Long male rod end (G)	0.10	0.15	0.21	0.34	0.70	0.97	1.84	2.85
	Female rod end (F)	0.08	0.12	0.19	0.29	0.60	0.85	1.61	2.53
Additional weight for bracket	Foot	0.11	0.13	0.16	0.22	0.48	0.72	0.96	1.75
	Flange	0.08	0.10	0.14	0.20	0.34	0.50	0.71	1.35
	Clevis	0.05	0.08	0.15	0.23	0.40	0.68	0.71	1.28
Pivoting bracket		0.08	0.09	0.17	0.25	0.44	0.80	0.98	1.75
Single knuckle joint		0.05	0.09	0.09	0.10	0.22	0.22	0.39	0.57
Double knuckle joint (with pin)		0.05	0.09	0.09	0.13	0.26	0.26	0.64	1.31
Additional weight per 50 mm of stroke		0.05	0.07	0.09	0.13	0.19	0.23	0.31	0.43
Additional weight for switch magnet		0.01	0.01	0.01	0.01	0.01	0.02	0.02	0.04

Calculation: (Example) **CDG3FN20-100** (Built-in magnet, Flange type, ø20, 100 mm stroke)

- Basic weight 0.09 (Basic type, ø20)
- Additional weight for bracket 0.08 (Flange)
- Additional weight for stroke 0.05/50 mm
- Air cylinder stroke 100 mm
- Additional weight for switch magnet 0.01

$$0.09 + 0.08 + 0.05 \times (100/50) + 0.01 = 0.28 \text{ kg}$$

Mounting Procedure

Mounting procedure for clevis

Follow the procedures below when mounting a pivoting bracket on the clevis type.

ø20 to ø63

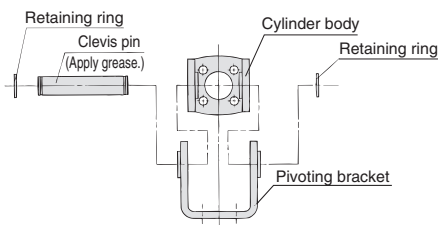

ø80, ø100

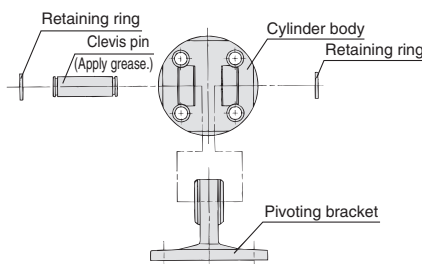

Mounting procedure for rod end nut

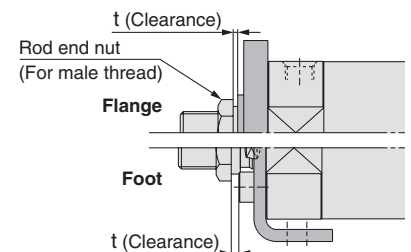

Caution

- 1. Tighten clevis bracket mounting bolts with the following proper tightening torque.**
 ø20: 1.5 N·m, ø25 to ø32: 2.9 N·m, ø40: 4.9 N·m
 ø50: 11.8 N·m, ø63 to ø80: 24.5 N·m, ø100: 42.2 N·m
- 2. For the flange type and the foot type, mount the rod end nut so that distance t (clearance) will be 1 mm or more in order to prevent interference of the nut with the bracket when the rod is retracted.**
- 3. The rod end nut (for male thread) should be mounted so that the hexagon part is on the rod end side. Apply the wrench to the hexagon part.**

Allowable Kinetic Energy

Table (1) Max. Allowable Kinetic Energy [J]

Bore size (mm)	20	25	32	40	50	63	80	100
Male rod end	0.2	0.29	0.46	0.84	1.4	2.38	4.13	6.93
Female rod end	0.11	0.18	0.29	0.52	0.91	1.54	2.71	4.54

Kinetic energy E (J) = $\frac{(m_1 + m_2) V^2}{2}$
 m₁: Mass of cylinder movable parts kg
 m₂: Load mass kg
 V: Piston speed at the end m/s

Table (2) Mass of Cylinder Movable Parts: At Each Rod End/Without Built-in Magnet/0 Stroke [g]

Bore size (mm)	20	25	32	40	50	63	80	100
Basic	30	54	74	121	254	297	603	935
Long male rod end (G)	36	64	89	146	300	343	683	1047
Female rod end (F)	23	40	62	91	184	226	462	728

* Mass of the rod end nut is included for the basic type and the long male rod end type (G).

Table (3) Additional Mass [g]

Bore size (mm)	20	25	32	40	50	63	80	100
Additional mass per 50 mm of stroke	20	31	44	61	99	99	148	207
Switch magnet	4	4	9	13	14	22	24	35

* Do not apply a lateral load over the allowable range to the rod end when it is mounted horizontally.

Calculation: (Example) CDG3BN40-150

- Standard mass of movable parts: Table (2) Rod end [Basic], Bore size [40] 121 g
- Additional mass: Additional mass of stroke 61 x 150/50 = 183 g 183 g
- Switch magnet 13 g

Total 317 g

Allowable Lateral Load at Rod End

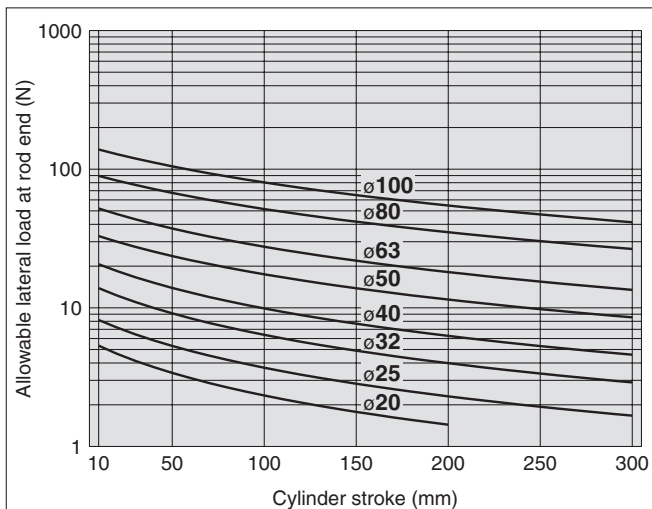

Construction

With rubber bumper

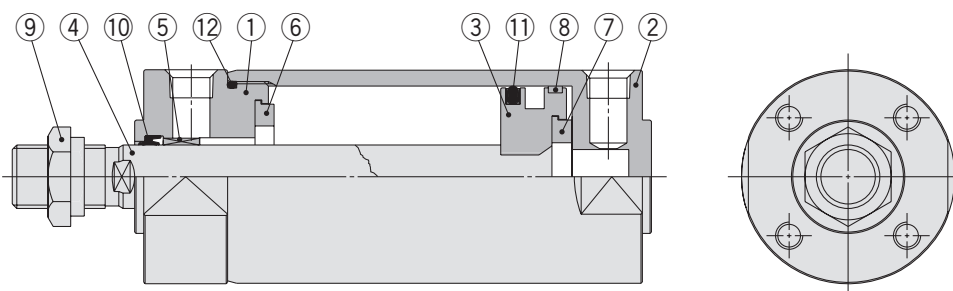

Component Parts

No.	Description	Material	Note
1	Rod cover	Aluminium alloy	Hard anodised
2	Tube cover	Aluminium alloy	Hard anodised
3	Piston	Aluminium alloy	Chromated
4	Piston rod	Iron*	Hard chrome plated*
5	Bushing	Copper alloy	
6	Bumper A	Urethane	
7	Bumper B	Urethane	
8	Wear ring	Resin	
9	Rod end nut	Iron	Nickel plated
10	Rod seal	NBR	
11	Piston seal	NBR	
12	Tube gasket	NBR	

Note) In the case of cylinders with auto switches, magnets are installed in the piston.
 * The material for ø20 and ø25 cylinders with auto switches is made of stainless steel.

Replacement Parts/Seal Kit

Bore size (mm)	Kit no.	Contents
20	CG3N20-PS	Set of the nos. (10, (1), (12)
25	CG3N25-PS	
32	CG3N32-PS	
40	CG3N40-PS	

Note) Refer to the following for disassembly/ replacement. Order with a part number for each type and bore size.
 * The seal kit includes a grease pack (10 g). Order with the following part number when only the grease pack is needed.
Grease pack part no.: GR-S-010 (10 g)

Caution

1. Do not replace the bushings. The bushings are press-fit. To replace them, they must be replaced together with the cover assembly.
2. To replace a seal, apply grease to the new seal before installing it. If the cylinder is put into operation without applying grease to the seal, it could cause the seal to wear significantly, leading to premature air leakage.

3. Cylinders with ø50 or larger bore sizes cannot be disassembled. When disassembling cylinders with bore sizes ø20 through ø40, grip the double flat part of either the head cover or the rod cover with a vise and loosen the other side with a wrench or a monkey wrench, etc., and then remove the cover. When re-tightening, tighten approximately 2 degrees more than the original position. (Cylinders with ø50 or larger bore sizes are tightened with a large tightening torque and cannot be disassembled. If disassembly is required, please contact SMC.)

Dimensions

Basic: CG3BN Bore size – Stroke

With rubber bumper

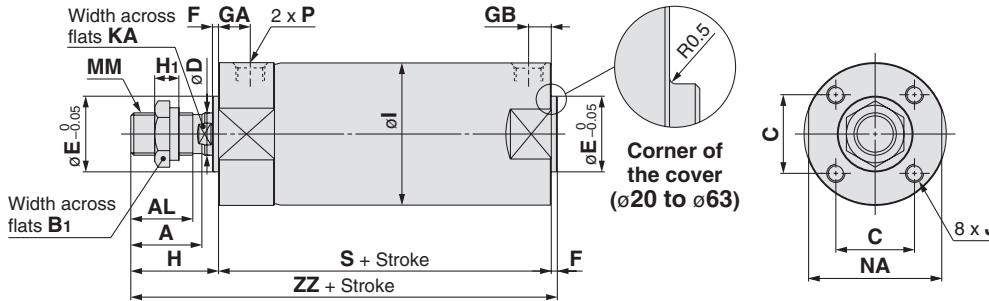

Female Rod End (mm)

Bore size (mm)	Standard stroke	A1	H	MM	ZZ
20	Up to 200	8	13	M4 x 0.7	72
25	Up to 300	8	14	M5 x 0.8	76
32	Up to 300	12	14	M6 x 1	78
40	Up to 300	13	15	M8 x 1.25	79
50	Up to 300	18	16	M10 x 1.5	102
63	Up to 300	18	16	M10 x 1.5	102
80	Up to 300	21	19	M14 x 1.5	126
100	Up to 300	25	22	M16 x 1.5	130

Long Male Rod End *2 (mm)

Bore size (mm)	Standard stroke	A	AL	H	ZZ
20	Up to 200	18	15.5	35	94
25	Up to 300	22	19.5	40	102
32	Up to 300	22	19.5	40	104
40	Up to 300	30	27	50	114
50	Up to 300	35	32	58	144
63	Up to 300	35	32	58	144
80	Up to 300	40	37	71	178
100	Up to 300	40	37	71	179

Female rod end

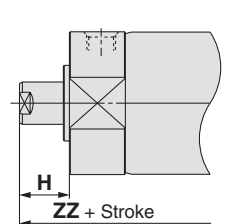

MM

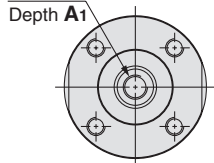

Long male rod end

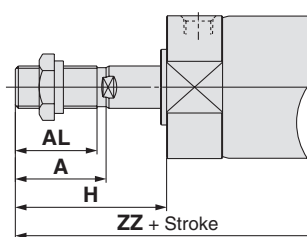

Basic

Bore size (mm)	Standard stroke	A	AL	B1	C	D	E	F	GA	GB	H	H1	I	J	KA	MM	NA	P	S	ZZ
20	Up to 200	14.5	12	13	14	8	12	2	12	6	20	5	26	M4 x 0.7 depth 7	Width across flats 6 length 3.5	M8 x 1.25	24	M5 x 0.8	57	79
25	Up to 300	17.5	15	17	16.5	10	14	2	12.5	7	23	6	31	M5 x 0.8 depth 7.5	Width across flats 8 length 3.5	M10 x 1.25	29	M5 x 0.8	60	85
32	Up to 300	17.5	15	17	20	12	18	2	11	7.5	23	6	38	M5 x 0.8 depth 8	Width across flats 10 length 3.5	M10 x 1.25	35.5	Rc1/8	62	87
40	Up to 300	23.5	20.5	19	26	14	25	2	10.5	7.5	29	8	47	M6 x 1 depth 10	Width across flats 12 length 3.5	M14 x 1.5	44	Rc1/8	62	93
50	Up to 300	29	26	27	32	18	30	2	15	12	35	11	58	M8 x 1.25 depth 16	Width across flats 16 length 4.5	M18 x 1.5	55	Rc1/4	84	121
63	Up to 300	29	26	27	38	18	32	2	15	12	35	11	72	M10 x 1.5 depth 16	Width across flats 16 length 4.5	M18 x 1.5	69	Rc1/4	84	121
80	Up to 300	35.5	32.5	32	50	22	40	3	17	16	44	13	89	M10 x 1.5 depth 22	Width across flats 19 length 4.5	M22 x 1.5	80	Rc1/4	104	151
100	Up to 300	35.5	32.5	41	60	26	50	3	20	16	44	16	110	M12 x 1.75 depth 22	Width across flats 22 length 4.5	M26 x 1.5	100	Rc3/8	105	152

*1 Use a thin wrench when tightening the piston rod.

*2 Long male rod end type (G) is the same rod end dimensions (A, AL, H) as the CG1 series.

*3 When female thread is used, use a washer, etc. to prevent the contact part at the rod end from being deformed depending on the material of the work piece.

Foot: CG3LN Bore size – Stroke

With rubber bumper

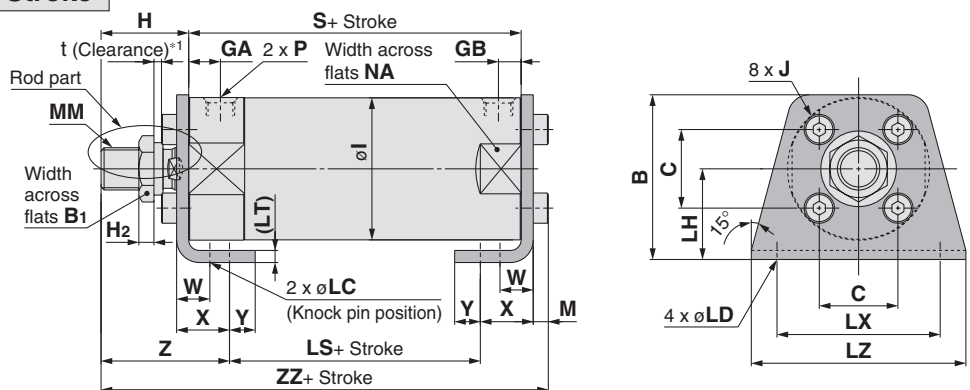
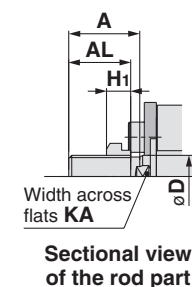

*1 The rod end nut should be mounted in the position t (clearance) so that it will have a clearance of 1 mm or more in order to prevent interference of the nut with the bolt for mounting bracket when the rod is retracted.

Foot

Symbol	A	AL	B	B1	C	D	GA	GB	H	H1	H2	I	J	KA	LCL	LDL	LHL	LS	LT	LX	LZ	M	MM	NA	P	S	W	X	Y	Z	ZZ
20	14.5	12	34	13	14	8	12	6	20	5	4	26	M4 x 0.7	Width across flats 6 length 3.5	4	6	20	33	(3)	32	44	3	M8 x 1.25	24	M5 x 0.8	57	10	15	7	32	83
25	17.5	15	38.5	17	16.5	10	12.5	7	23	6	4	31	M5 x 0.8	Width across flats 8 length 3.5	4	6	22	36	(3)	36	49	3.5	M10 x 1.25	29	M5 x 0.8	60	10	15	7	35	89.5
32	17.5	15	45	17	20	12	11	7.5	23	6	4	38	M5 x 0.8	Width across flats 10 length 3.5	4	7	25	36	(3)	44	58	3.5	M10 x 1.25	35.5	Rc1/8	62	10	16	8	36	91.5
40	23.5	20.5	54.5	19	26	14	10.5	7.5	29	8	5.5	47	M6 x 1	Width across flats 12 length 3.5	4	7	30	35	(3)	54	71	4	M14 x 1.5	44	Rc1/8	62	10	16.5	8.5	42.5	98
50	29	26	70.5	27	32	18	15	12	35	11	8	58	M8 x 1.25	Width across flats 16 length 4.5	5	10	40	49	(4.5)	66	86	5	M18 x 1.5	55	Rc1/4	84	17.5	22	11	52.5	128.5
63	29	26	82.5	27	38	18	15	12	35	11	8	72	M10 x 1.5	Width across flats 16 length 4.5	5	12	45	49	(4.5)	82	106	5	M18 x 1.5	69	Rc1/4	84	17.5	22	13	52.5	128.5
80	35.5	32.5	101	32	50	22	17	16	44	13	9.5	89	M10 x 1.5	Width across flats 19 length 4.5	6	11	55	56	(4.5)	100	125	5	M22 x 1.5	80	Rc1/4	104	20	28.5	14	68	157.5
100	35.5	32.5	121	41	60	26	20	16	44	16	9.5	110	M12 x 1.75	Width across flats 22 length 4.5	6	14	65	57	(6)	120	150	7	M26 x 1.5	100	Rc3/8	105	20	30	16	68	162

* Use a thin wrench when tightening the piston rod.

* Refer to the dimensions of the basic type for the female rod end type and the long male rod end type.

Series CG3

Dimensions

Rod Flange: CG3FN Bore size – Stroke

With rubber bumper

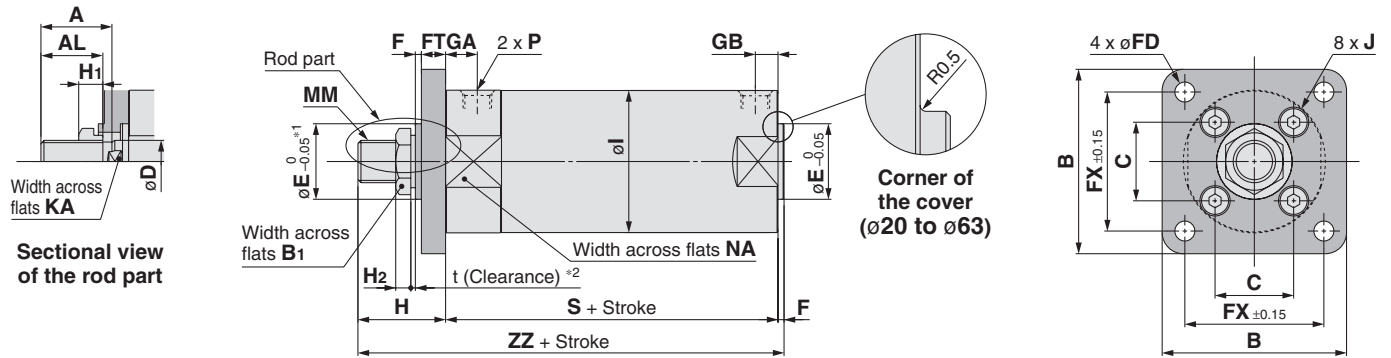

*1 End boss is machined on the flange for øE.

*2 The rod end nut should be mounted in the position t (clearance) so that it will have a clearance of 1 mm or more in order to prevent interference of the nut with the bolt for mounting bracket when the rod is retracted.

Rod Flange

Symbol	A	AL	B	B ₁	C	D	E	F	FX	FD	FT	GA	GB	H	H ₁	H ₂	I	J	KA	MM	NA	P	S	ZZ
20	14.5	12	40	13	14	8	12	2	28	5.5	6	12	6	20	5	4	26	M4 x 0.7	Width across flats 6 length 3.5	M8 x 1.25	24	M5 x 0.8	57	79
25	17.5	15	44	17	16.5	10	14	2	32	5.5	7	12.5	7	23	6	4	31	M5 x 0.8	Width across flats 8 length 3.5	M10 x 1.25	29	M5 x 0.8	60	85
32	17.5	15	53	17	20	12	18	2	38	6.6	7	11	7.5	23	6	4	38	M5 x 0.8	Width across flats 10 length 3.5	M10 x 1.25	35.5	Rc1/8	62	87
40	23.5	20.5	61	19	26	14	25	2	46	6.6	8	10.5	7.5	29	8	5.5	47	M6 x 1	Width across flats 12 length 3.5	M14 x 1.5	44	Rc1/8	62	93
50	29	26	76	27	32	18	30	2	58	9	9	15	12	35	11	8	58	M8 x 1.25	Width across flats 16 length 4.5	M18 x 1.5	55	Rc1/4	84	121
63	29	26	92	27	38	18	32	2	70	11	9	15	12	35	11	8	72	M10 x 1.5	Width across flats 16 length 4.5	M18 x 1.5	69	Rc1/4	84	121
80	35.5	32.5	104	32	50	22	40	3	82	11	11	17	16	44	13	9.5	89	M10 x 1.5	Width across flats 19 length 4.5	M22 x 1.5	80	Rc1/4	104	151
100	35.5	32.5	128	41	60	26	50	3	100	14	14	20	16	44	16	9.5	110	M12 x 1.75	Width across flats 22 length 4.5	M26 x 1.5	100	Rc3/8	105	152

* Use a thin wrench when tightening the piston rod.

* Refer to the dimensions of the basic type for the female rod end type and the long male rod end type.

Head Flange: CG3GN Bore size – Stroke

With rubber bumper

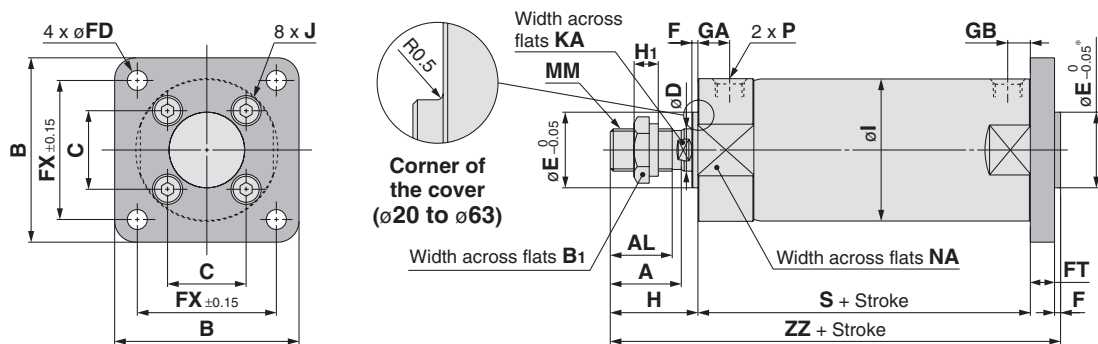

* End boss is machined on the flange for øE.

Head Flange

Bore size (mm)	Standard stroke	A	AL	B	B ₁	C	D	E	F	FX	FD	FT	GA	GB	H	H ₁	I	J	KA	MM	NA	P	S	ZZ
20	Up to 200	14.5	12	40	13	14	8	12	2	28	5.5	6	12	6	20	5	26	M4 x 0.7	Width across flats 6 length 3.5	M8 x 1.25	24	M5 x 0.8	57	85
25	Up to 300	17.5	15	44	17	16.5	10	14	2	32	5.5	7	12.5	7	23	6	31	M5 x 0.8	Width across flats 8 length 3.5	M10 x 1.25	29	M5 x 0.8	60	92
32	Up to 300	17.5	15	53	17	20	12	18	2	38	6.6	7	11	7.5	23	6	38	M5 x 0.8	Width across flats 10 length 3.5	M10 x 1.25	35.5	Rc1/8	62	94
40	Up to 300	23.5	20.5	61	19	26	14	25	2	46	6.6	8	10.5	7.5	29	8	47	M6 x 1	Width across flats 12 length 3.5	M14 x 1.5	44	Rc1/8	62	101
50	Up to 300	29	26	76	27	32	18	30	2	58	9	9	15	12	35	11	58	M8 x 1.25	Width across flats 16 length 4.5	M18 x 1.5	55	Rc1/4	84	130
63	Up to 300	29	26	92	27	38	18	32	2	70	11	9	15	12	35	11	72	M10 x 1.5	Width across flats 16 length 4.5	M18 x 1.5	69	Rc1/4	84	130
80	Up to 300	35.5	32.5	104	32	50	22	40	3	82	11	11	17	16	44	13	89	M10 x 1.5	Width across flats 19 length 4.5	M22 x 1.5	80	Rc1/4	104	162
100	Up to 300	35.5	32.5	128	41	60	26	50	3	100	14	14	20	16	44	16	110	M12 x 1.75	Width across flats 22 length 4.5	M26 x 1.5	100	Rc3/8	105	166

* Use a thin wrench when tightening the piston rod.

* Refer to the dimensions of the basic type for the female rod end type and the long male rod end type.

Dimensions

Clevis: CG3DN Bore size – Stroke (ø20 to ø63)

With rubber bumper

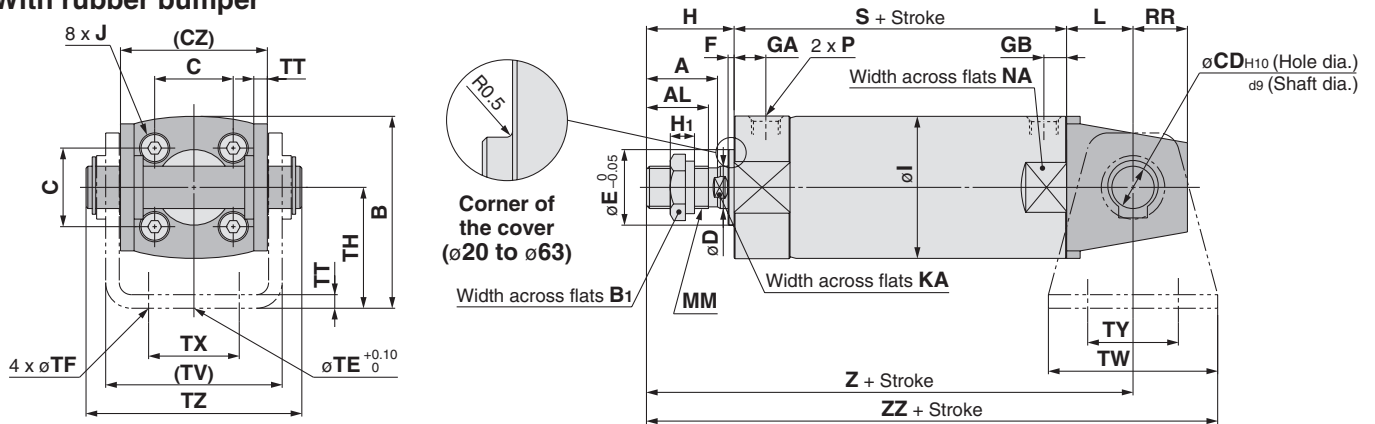

Clevis (ø20 to ø63)

Bore size (mm)	Standard stroke	A	AL	B	B ₁	C	CD	CZ	D	E	F	GA	GB	H	H ₁	I	J	KA	L	MM
20	Up to 200	14.5	12	38	13	14	8	(29)	8	12	2	12	6	20	5	26	M4 x 0.7	Width across flats 6 length 3.5	14	M8 x 1.25
25	Up to 300	17.5	15	45.5	17	16.5	10	(33)	10	14	2	12.5	7	23	6	31	M5 x 0.8	Width across flats 8 length 3.5	16	M10 x 1.25
32	Up to 300	17.5	15	54	17	20	12	(40)	12	18	2	11	7.5	23	6	38	M5 x 0.8	Width across flats 10 length 3.5	20	M10 x 1.25
40	Up to 300	23.5	20.5	63.5	19	26	14	(49)	14	25	2	10.5	7.5	29	8	47	M6 x 1	Width across flats 12 length 3.5	22	M14 x 1.5
50	Up to 300	29	26	79	27	32	16	(60)	18	30	2	15	12	35	11	58	M8 x 1.25	Width across flats 16 length 4.5	25	M18 x 1.5
63	Up to 300	29	26	96	27	38	18	(74)	18	32	2	15	12	35	11	72	M10 x 1.5	Width across flats 16 length 4.5	30	M18 x 1.5

Bore size (mm)	Standard stroke	NA	P	RR	S	TE	TF	TH	TT	TV	TW	TX	TY	TZ	Z	ZZ	Applicable pin part no.
20	Up to 200	24	M5 x 0.8	11	57	10	5.5	25	3.2	(35.8)	42	16	28	43.4	91	112	CD-G02
25	Up to 300	29	M5 x 0.8	13	60	10	5.5	30	3.2	(39.8)	42	20	28	48	99	120	CD-G25
32	Up to 300	35.5	Rc1/8	15	62	10	6.6	35	4.5	(49.4)	48	22	28	59.4	105	129	CD-G03
40	Up to 300	44	Rc1/8	18	62	10	6.6	40	4.5	(58.4)	56	30	30	71.4	113	141	CD-G04
50	Up to 300	55	Rc1/4	20	84	20	9	50	6	(72.4)	64	36	36	86	144	176	CD-G05
63	Up to 300	69	Rc1/4	22	84	20	11	60	8	(90.4)	74	46	46	105.4	149	186	CD-G06

* Use a thin wrench when tightening the piston rod. * Refer to the dimensions of the basic type for the female rod end type and the long male rod end type.
* Refer to page 8 for pivoting bracket.

Clevis: CG3DN Bore size – Stroke (ø80, ø100)

With rubber bumper

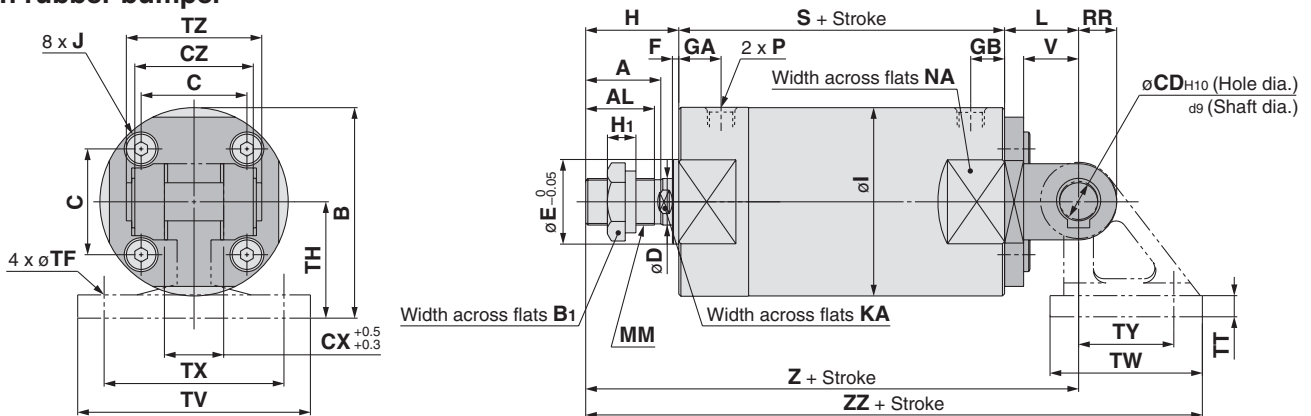

Clevis (ø80, ø100)

Bore size (mm)	Standard stroke	A	AL	B	B ₁	C	CD	CX	CZ	D	E	F	GA	GB	H	H ₁	I	J	KA	L
80	Up to 300	35.5	32.5	99.5	32	50	18	28	56	22	40	3	17	16	44	13	89	M10 x 1.5	Width across flats 19 length 4.5	35
100	Up to 300	35.5	32.5	120	41	60	22	32	64	26	50	3	20	16	44	16	110	M12 x 1.75	Width across flats 22 length 4.5	43

Bore size (mm)	Standard stroke	MM	NA	P	RR	S	TF	TH	TT	TV	TW	TX	TY	TZ	V	Z	ZZ	Applicable pin part no.
80	Up to 300	M22 x 1.5	80	Rc1/4	18	104	11	55	11	110	72	85	45	64	26	183	241.5	IY-G08
100	Up to 300	M26 x 1.5	100	Rc3/8	22	105	13.5	65	12	130	93	100	60	72	32	192	268.5	IY-G10

* Use a thin wrench when tightening the piston rod. * Refer to the dimensions of the basic type for the female rod end type and the long male rod end type.
* Refer to page 8 for pivoting bracket.

Auto Switch Proper Mounting Position (Detection at stroke end) and Its Mounting Height

Reed auto switch

D-A9□

∅20 to ∅63

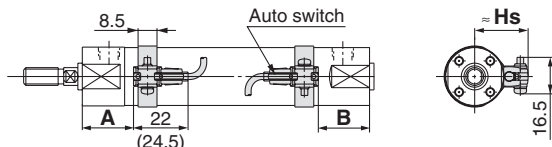

() : Dimensions of D-A93 type

D-C73C/C80C

∅20 to ∅63

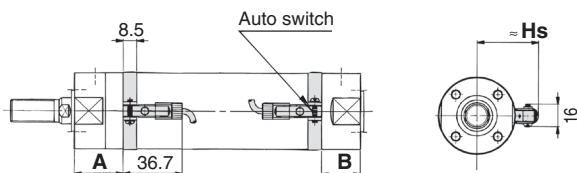

D-B54/B64/B59W

∅20 to ∅100

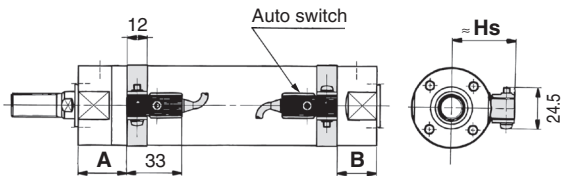

Solid state auto switch

D-M9□

D-M9□W

∅20 to ∅63

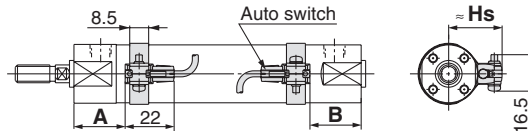

D-G5□/K59/G5□W/G5BAL,

D-K59W/G59F/G5NTL

∅20 to ∅100

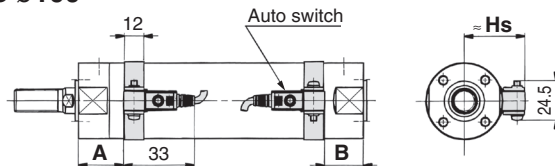

D-H7NF/H7BAL

∅20 to ∅63

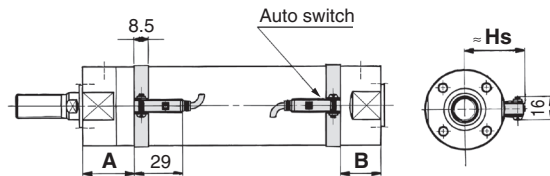

D-H7C

∅20 to ∅63

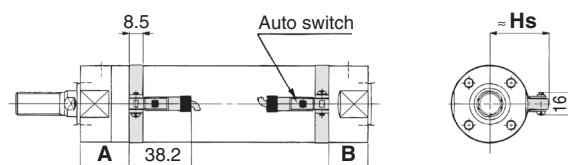

Auto Switch Proper Mounting Position

(mm)

Auto switch model	D-M9□ D-M9□W		D-A9□		D-C73C D-C80C		D-B54 D-B64		D-B59W		D-H7C D-H7BAL D-H7NF		D-G5□W D-K59W D-G59F D-G5□ D-K59 D-G5NTL D-G5BAL	
	A	B	A	B	A	B	A	B	A	B	A	B	A	B
Bore size 20	28.5	16.5	24.5	12.5	25	13	19	8	22	10	24	12	20.5	8.5
25	29	19	25	15	25.5	15.5	19.5	9.5	22.5	12.5	24.5	14.5	21	11
32	30.5	19.5	26.5	15.5	27	16	21	10	24	13	26	15	22.5	11.5
40	31	19	27	15	27.5	15.5	—	—	—	—	26.5	14.5	—	—
50	42.5	29.5	38.5	25.5	39	26	33	20	36	23	38	25	34.5	21.5
63	42.5	29.5	38.5	25.5	39	26	33	20	36	23	38	25	34.5	21.5
80	—	—	—	—	—	—	44	29	47	31.5	—	—	45.5	30.5
100	—	—	—	—	—	—	44	30	47	32.5	—	—	45.5	31.5

Auto Switch Mounting Height

(mm)

Auto switch model	D-M9□ D-M9□W D-A9□		D-H7NF D-H7BAL	D-C73C D-C80C	D-B54/B64 D-B59W D-G5□/K59 D-G5□W D-K59W D-G5NTL D-G59F D-H7C D-G5BAL
	Hs	Hs	Hs	Hs	Hs
Bore size 20	24	24.5	27	27.5	27.5
25	26.5	27	29.5	30	30
32	30	30.5	33	33.5	33.5
40	34.5	35	37.5	—	—
50	40	40.5	43	43.5	43.5
63	47	47.5	50	50.5	50.5
80	—	—	—	59	59
100	—	—	—	69.5	69.5

Note 1) Adjust the auto switch after confirming the operating condition in the actual setting.

Note 2) For the combination of the following auto switches, bore sizes and mounting positions, the auto switch cannot be mounted to the port side.

- D-H7□ type ... On the head side of the bore size ∅20, ∅25, ∅32, ∅40, ∅50, ∅63
- D-A9□/C7□/C8 types ... On the head side of the bore size ∅20, ∅32, ∅40
- D-G5□/K5□/B59W types ... On the head side of the bore size ∅20, ∅25, ∅32, ∅50, ∅63
- D-B5□/B6□ types ... On the head side of the bore size ∅20, ∅25, ∅32, ∅50, ∅63, ∅80, ∅100 and the rod side of the bore size ∅20, ∅25, ∅32

Minimum Stroke for Auto Switch Mounting

n: Number of auto switches (mm)

Auto switch model	Number of auto switches				
	With 1 pc.	With 2 pcs.		With n pcs.	
		Different surfaces	Same surface	Different surfaces	Same surface
D-M9□ D-M9□W D-A9□	10	15 <small>Note 1)</small>	45 <small>Note 1)</small>	$15 + 45 \frac{(n-2)}{2}$ (n = 2, 4, 6...)	45 + 45 (n - 2)
D-H7BAL D-H7NF	10	15	60	$15 + 45 \frac{(n-2)}{2}$ (n = 2, 4, 6...)	60 + 45 (n - 2)
D-C73C D-C80C	10	15	65	$15 + 50 \frac{(n-2)}{2}$ (n = 2, 4, 6...)	65 + 50 (n - 2)
D-B54 D-B64 D-G5□ D-G5□W D-K59 D-K59W D-G5BAL D-G59F D-G5NTL	10	15	75	$15 + 50 \frac{(n-2)}{2}$ (n = 2, 4, 6...)	75 + 55 (n - 2)
D-B59W	15	20	75	$20 + 50 \frac{(n-2)}{2}$ (n = 2, 4, 6...)	75 + 55 (n - 2)

Note 1) Auto switch mounting

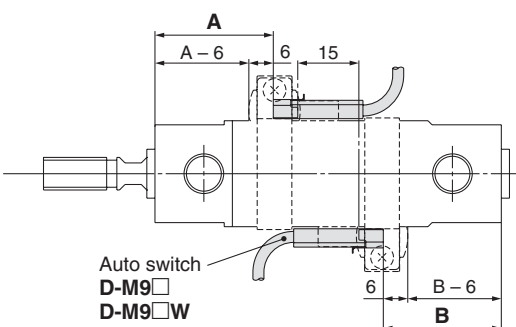
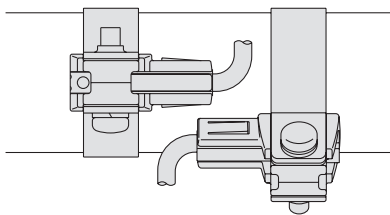
Auto switch model	With 2 auto switches	
	Different surfaces <small>Note 1)</small>	Same surface <small>Note 1)</small>
 <p>The auto switch proper mounting position is 6 mm inward from the switch holder edge.</p>	 <p>The auto switch is mounted by slightly displacing it in a direction (cylinder tube circumferential exterior) so that the auto switch and lead wire do not interfere with each other.</p>	
D-M9□ D-M9□W	Less than 20 mm stroke <small>Note 2)</small>	Less than 55 mm stroke <small>Note 2)</small>
D-A93	—	Less than 50 mm stroke <small>Note 2)</small>

Note 2) Minimum stroke for auto switch mounting in styles other than those mentioned in Note 1

Operating Range

(mm)

Auto switch model	Bore size							
	20	25	32	40	50	63	80	100
D-M9□ D-M9□W	4.5	5.0	4.5	5.5	5.0	5.5	—	—
D-A9□	7	6	8	8	8	9	—	—
D-C73C/C80C	8	10	9	10	10	11	—	—
D-B54/B64	8	10	9	—	10	11	11	11
D-B59W	13	13	14	—	14	17	16	18
D-H7NF/H7BAL	4	4	4.5	5	6	6.5	—	—
D-H7C	7	8.5	9	10	9.5	10.5	—	—
D-G5□/G5□W/G59F D-G5BAL/K59/K59W	4	4	4.5	—	6	6.5	6.5	7
D-G5NTL	4	4	4.5	—	6	6.5	6.5	7
D-G5NBL	35	40	40	—	45	45	45	50

* Values which include hysteresis are for guideline purposes only, they are not a guarantee (assuming approximately ±30% dispersion) and may change substantially depending on the ambient environment.

Auto Switch Mounting Brackets/Part No.

Auto switch model	Bore size (mm)							
	ø20	ø25	ø32	ø40	ø50	ø63	ø80	ø100
D-M9□ D-M9□W D-A9□	Note 1) ① BMA2-020 ② BJ3-1	Note 1) ① BMA2-025 ② BJ3-1	Note 1) ① BMA2-032 ② BJ3-1	Note 1) ① BMA2-040 ② BJ3-1	Note 1) ① BMA2-050 ② BJ3-1	Note 1) ① BMA2-063 ② BJ3-1	—	—
D-C73C D-C80C D-H7BAL D-H7NF	BMA2-020	BMA2-025	BMA2-032	BMA2-040	BMA2-050	BMA2-063	—	—
D-B54/B64 D-B59W D-G5□/K59 D-G5□W/K59W D-G5BAL/G59F D-G5NTL D-G5NBL	BA-01	BA-02	BA-32	—	BA-05	BA-06	BA-08	BA-10

Note 1) Two kinds of auto switch mounting brackets are used as a set.

[Stainless Steel Mounting Screw]

The following set of stainless steel mounting screws is available. Use them in accordance with the operating environment. (Since auto switch mounting brackets are not included, order them separately.)

BBA3: For D-B5/B6/G5/K5 types

BBA4: For D-C7/C8/H7 types

Note 2) Refer to pages 1357 and 1358 in Best Pneumatics No. 2 for details of BBA3 and BBA4 screws.

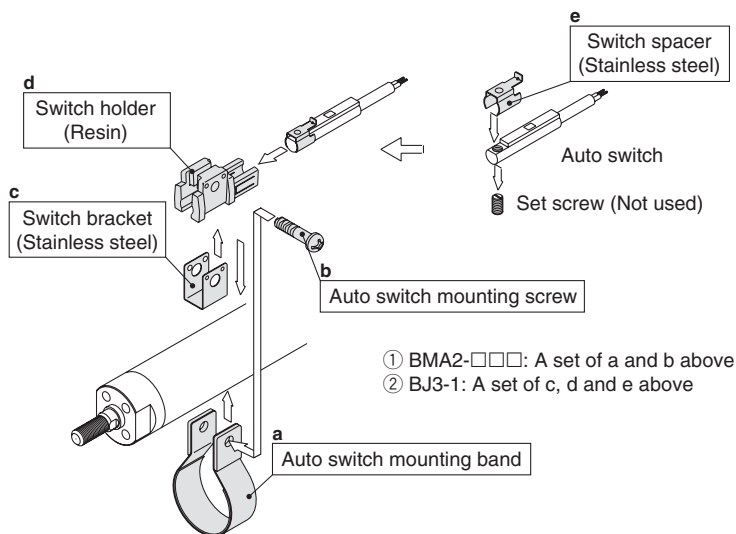

The above stainless steel screws are used when a cylinder is shipped with the D-H7BAL/G5BAL auto switches.

When only an auto switch is shipped independently, BBA3 or BBA4 screws are attached.



Cylinder Mounting Bracket, by Stroke/Auto Switch Mounting Surfaces

st: Stroke (mm)

Auto switch model	Basic, Foot, Flange, Clevis		
	With 1 pc. (Rod cover side)	With 2 pcs. (Different surfaces)	With 2 pcs. (Same surface)
Auto switch mounting surface	Port side 	Port side 	Port side 
Auto switch model			
D-M9□ D-M9□W D-A9□	10 st or more	15 to 44 st	45 st or more
D-H7BAL/H7NF	10 st or more	15 to 59 st	60 st or more
D-C73C/C80C/H7C	10 st or more	15 to 64 st	65 st or more
D-B54/B64/G5□/K59 D-G5□W/K59W/G5BAL D-G59F/G5NTL	10 st or more	15 to 74 st	75 st or more
D-B59W	15 st or more	20 to 74 st	75 st or more

Other than the auto switches listed in the “How to Order”, the following auto switches can also be mounted. Refer to pages 1263 to 1371 in Best Pneumatics No. 2 for detailed specifications.

- * With pre-wired connector is also available for solid state auto switches. For details, refer to pages 1328 and 1329 in Best Pneumatics No. 2.
- * Normally closed (NC = b contact) solid state auto switches (D-F9G/F9H) are also available. For details, refer to page 1290 in Best Pneumatics No. 2.
- * Solid state auto switch with timer (D-G5NTL) is also available. For details, refer to page 1313 in Best Pneumatics No. 2.
- * Wide range detection type, solid state auto switch (D-G5NBL) is also available. For details, refer to page 1320 in Best Pneumatics No. 2.

Prior to Use

Auto Switch Connection and Example

Basic Wiring

Solid state 3-wire, NPN

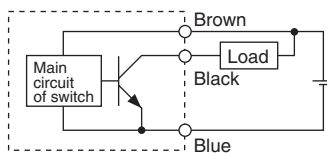

Solid state 3-wire, PNP

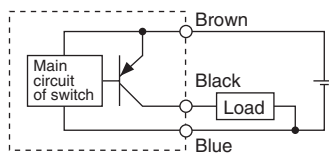

2-wire (Solid state)

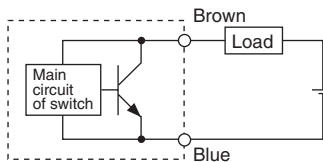

2-wire (Reed)

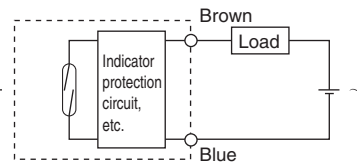

(Power supply for switch and load are separate.)

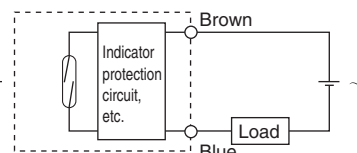
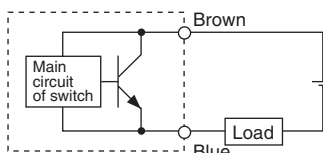
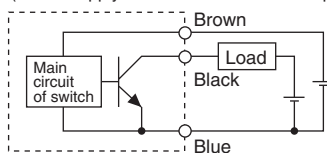

Example of Connection with PLC (Programmable Logic Controller)

• Sink input specifications 3-wire, NPN

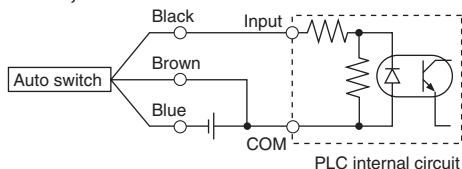

• Source input specifications 3-wire, PNP

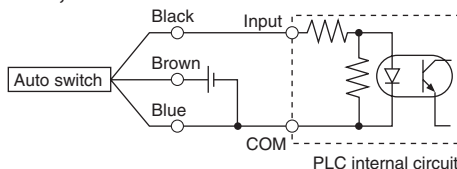

Connect according to the applicable PLC input specifications, as the connection method will vary depending on the PLC input specifications.

2-wire

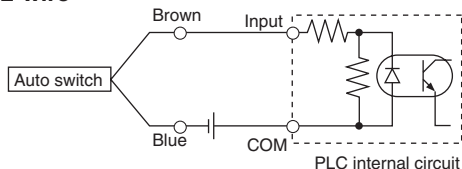

2-wire

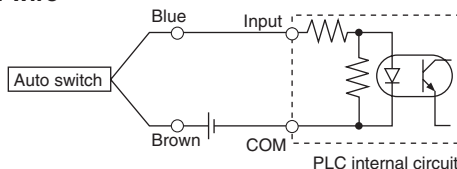

Example of AND (Series) and OR (Parallel) Connection

• 3-wire

AND connection for NPN output (Using relays)

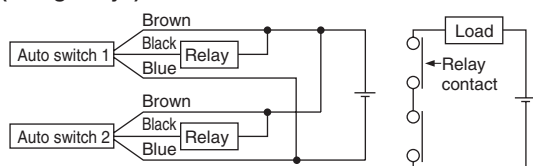

AND connection for NPN output (Performed with auto switches only)

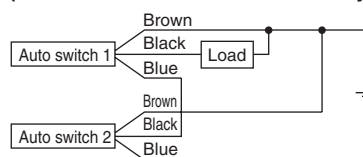

OR connection for NPN output

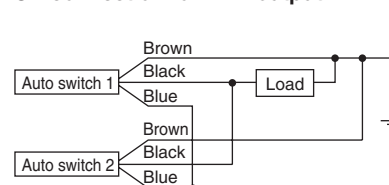

The indicator lights will light up when both of the auto switches are in the ON state.

• 2-wire

2-wire with 2-switch AND connection

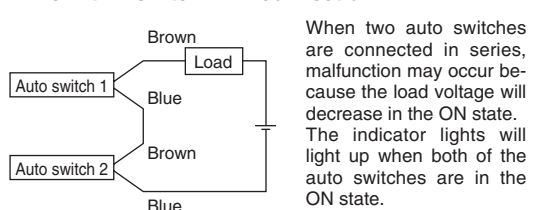

When two auto switches are connected in series, malfunction may occur because the load voltage will decrease in the ON state. The indicator lights will light up when both of the auto switches are in the ON state.

$$\begin{aligned} \text{Load voltage at ON} &= \text{Power supply voltage} - \text{Residual voltage} \times 2 \text{ pcs.} \\ &= 24 \text{ V} - 4 \text{ V} \times 2 \text{ pcs.} \\ &= 16 \text{ V} \end{aligned}$$

Example: Power supply voltage 24 VDC
Auto switch internal voltage drop 4 V

2-wire with 2-switch OR connection

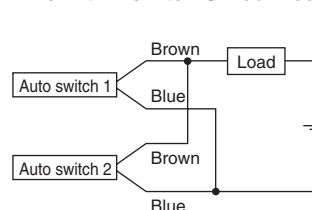

(Solid state)
When two auto switches are connected in parallel, malfunction may occur because the load voltage will increase in the OFF state.



$$\begin{aligned} \text{Load voltage at OFF} &= \text{Leakage current} \times 2 \text{ pcs.} \times \text{Load impedance} \\ &= 1 \text{ mA} \times 2 \text{ pcs.} \times 3 \text{ k}\Omega \\ &= 6 \text{ V} \end{aligned}$$

Example: Load impedance 3 kΩ
Auto switch leakage current 1 mA

(Reed)
Because there is no leakage current, the load voltage will not increase in the OFF state. However, depending on the number of auto switches in the ON state, the indicator lights may sometimes grow dim or not light up, due to the dispersion and reduction of the current flowing to the auto switches.

Safety Instructions

These safety instructions are intended to prevent hazardous situations and/or equipment damage. These instructions indicate the level of potential hazard with the labels of “**Caution**,” “**Warning**” or “**Danger**.” They are all important notes for safety and must be followed in addition to International Standards (ISO/IEC)*1), and other safety regulations.

-  **Caution:** **Caution** indicates a hazard with a low level of risk which, if not avoided, could result in minor or moderate injury.
-  **Warning:** **Warning** indicates a hazard with a medium level of risk which, if not avoided, could result in death or serious injury.
-  **Danger:** **Danger** indicates a hazard with a high level of risk which, if not avoided, will result in death or serious injury.

- *1) ISO 4414: Pneumatic fluid power – General rules relating to systems.
 ISO 4413: Hydraulic fluid power – General rules relating to systems.
 IEC 60204-1: Safety of machinery – Electrical equipment of machines.
 (Part 1: General requirements)
 ISO 10218-1: Manipulating industrial robots - Safety.
 etc.

Warning

- 1. The compatibility of the product is the responsibility of the person who designs the equipment or decides its specifications.**
 Since the product specified here is used under various operating conditions, its compatibility with specific equipment must be decided by the person who designs the equipment or decides its specifications based on necessary analysis and test results. The expected performance and safety assurance of the equipment will be the responsibility of the person who has determined its compatibility with the product. This person should also continuously review all specifications of the product referring to its latest catalogue information, with a view to giving due consideration to any possibility of equipment failure when configuring the equipment.
- 2. Only personnel with appropriate training should operate machinery and equipment.**
 The product specified here may become unsafe if handled incorrectly. The assembly, operation and maintenance of machines or equipment including our products must be performed by an operator who is appropriately trained and experienced.
- 3. Do not service or attempt to remove product and machinery/equipment until safety is confirmed.**
 1. The inspection and maintenance of machinery/equipment should only be performed after measures to prevent falling or runaway of the driven objects have been confirmed.
 2. When the product is to be removed, confirm that the safety measures as mentioned above are implemented and the power from any appropriate source is cut, and read and understand the specific product precautions of all relevant products carefully.
 3. Before machinery/equipment is restarted, take measures to prevent unexpected operation and malfunction.
- 4. Contact SMC beforehand and take special consideration of safety measures if the product is to be used in any of the following conditions.**
 1. Conditions and environments outside of the given specifications, or use outdoors or in a place exposed to direct sunlight.
 2. Installation on equipment in conjunction with atomic energy, railways, air navigation, space, shipping, vehicles, military, medical treatment, combustion and recreation, or equipment in contact with food and beverages, emergency stop circuits, clutch and brake circuits in press applications, safety equipment or other applications unsuitable for the standard specifications described in the product catalogue.
 3. An application which could have negative effects on people, property, or animals requiring special safety analysis.
 4. Use in an interlock circuit, which requires the provision of double interlock for possible failure by using a mechanical protective function, and periodical checks to confirm proper operation.

Caution

- 1. The product is provided for use in manufacturing industries.**
 The product herein described is basically provided for peaceful use in manufacturing industries.
 If considering using the product in other industries, consult SMC beforehand and exchange specifications or a contract if necessary.
 If anything is unclear, contact your nearest sales branch.

Limited warranty and Disclaimer/ Compliance Requirements

The product used is subject to the following “Limited warranty and Disclaimer” and “Compliance Requirements”.
 Read and accept them before using the product.

Limited warranty and Disclaimer

1. The warranty period of the product is 1 year in service or 1.5 years after the product is delivered.*2)
 Also, the product may have specified durability, running distance or replacement parts. Please consult your nearest sales branch.
2. For any failure or damage reported within the warranty period which is clearly our responsibility, a replacement product or necessary parts will be provided.
 This limited warranty applies only to our product independently, and not to any other damage incurred due to the failure of the product.
3. Prior to using SMC products, please read and understand the warranty terms and disclaimers noted in the specified catalogue for the particular products.

*2) **Vacuum pads are excluded from this 1 year warranty.**

A vacuum pad is a consumable part, so it is warranted for a year after it is delivered.
 Also, even within the warranty period, the wear of a product due to the use of the vacuum pad or failure due to the deterioration of rubber material are not covered by the limited warranty.

Compliance Requirements

1. The use of SMC products with production equipment for the manufacture of weapons of mass destruction (WMD) or any other weapon is strictly prohibited.
2. The exports of SMC products or technology from one country to another are governed by the relevant security laws and regulations of the countries involved in the transaction. Prior to the shipment of a SMC product to another country, assure that all local rules governing that export are known and followed.

Safety Instructions

Be sure to read “Handling Precautions for SMC Products” (M-E03-3) before using.