

## Standards-based cylinders DSBG, ISO 15552



This is the advised replacement for the DNG series\*  
\*Please check your specifications carefully!

**FESTO**

Standards-based cylinders DSBG, ISO 15552









Key features

At a glance

- 

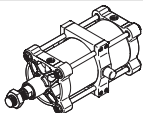
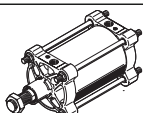

  - Standards-based cylinders to ISO 15552 (corresponds to the withdrawn standards ISO 6431, DIN ISO 6431, VDMA24562, NFE49003.1 and UNI 10290)
  - Sturdy tie rod design
  - Double-acting
  - For contactless position sensing
  - EX4: for use in potentially explosive areas
  - An extensive range of accessories enables the cylinders to be installed virtually anywhere
  - Choice of two cushioning types:
    - Elastic cushioning: elastic cushioning rings/pads at both ends
    - PPV cushioning: pneumatic cushioning, adjustable at both ends
  - The variants can be configured according to individual needs using a modular product system
  - Excellent flexibility thanks to the wide range of variants

Variants from the modular product system

Symbol	Key features	Description
	T Through piston rod	For working at both ends with the same force in the forward and return stroke, for attaching external stops
	F Female piston rod thread	–
	R3 High corrosion protection	All external cylinder surfaces comply with corrosion resistance class 3 to Festo standard 940 070. The piston rod is made from corrosion and acid-resistant steel
	T1 Heat-resistant seals	Temperature range 0 ... +120°C
	T4 Heat-resistant seals	Temperature range 0 ... +150°C
	...E Extended piston rod	1 ... 500 mm
	...L Extended piston rod thread	1 ... 100 mm
	...S Shortened piston rod thread	1 ... 86 mm
	M... Piston rod thread	Piston rod thread version: M16/M16x1.5/M20/M20x1.5/M24/M27/M27x2/M30x2/M36/ M36x2/M42/M42x2/M48
	A6 Scraper variant	Metal scraper: The cylinder is fitted with a hard-chrome plated piston rod and a metal scraper, which scrapes off hard particles (e.g. welding spatter) sticking to the piston rod. For use in welding systems, for example
	V Central swivel mounting	<ul style="list-style-type: none"> <li>• For piston diameter 160, 200</li> <li>• Swivel mounting, clamped centrally between the cylinder end caps</li> <li>• Position can be moved at any time</li> </ul>
	...Y Trunnion flange mounting position	<ul style="list-style-type: none"> <li>• For piston diameter 250, 320</li> <li>• Swivel mounting, position freely selectable, positive-locking screw connection</li> <li>• Position cannot be changed at a later date</li> </ul>
	B Integrated spacer bolts	<ul style="list-style-type: none"> <li>• B1: at both ends</li> <li>• B2: on the bearing cap</li> <li>• B3: on the end cap</li> </ul>
	Thread length of spacer bolts: ...LB2 on the bearing cap ...LB3 on the end cap	<ul style="list-style-type: none"> <li>• Variable thread length: 32 ... 140 mm</li> <li>• Optionally on the bearing or end cap</li> </ul>

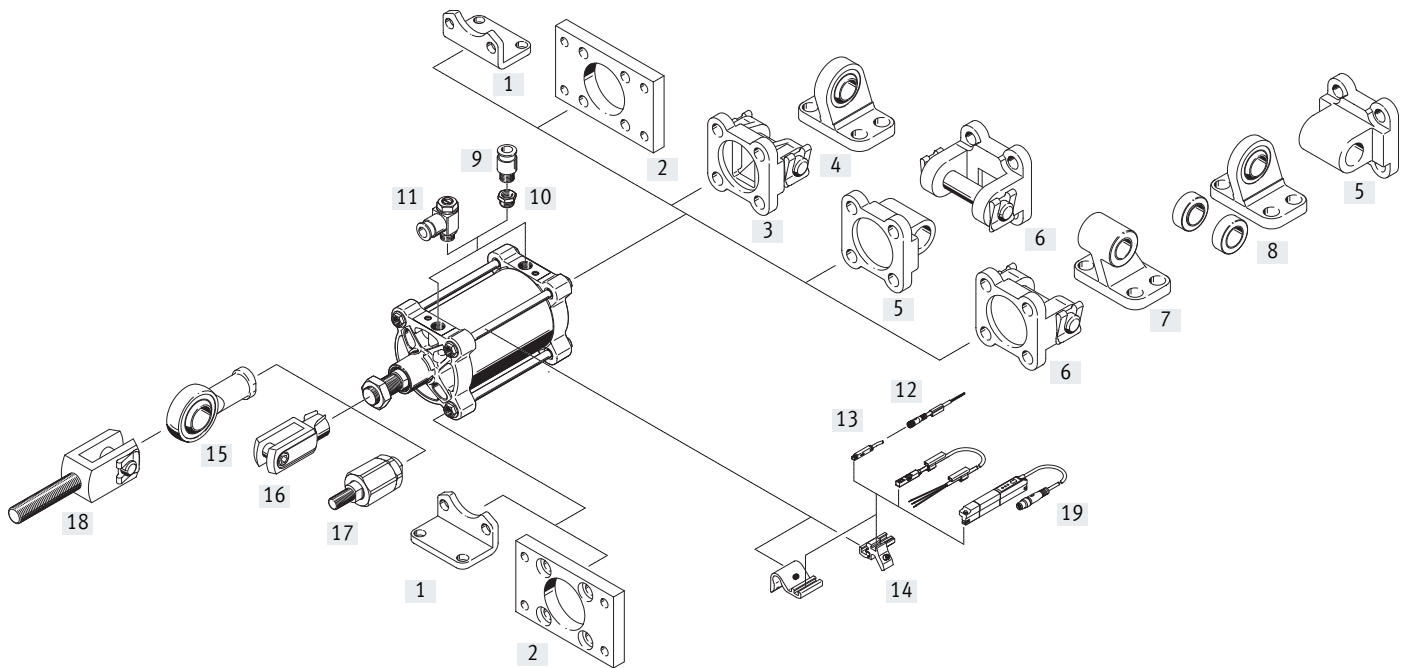
Peripherals overview



**Mounting components and accessories**

	For diameter	Description	→ Page/ Internet
[1] Foot mounting HNG	160 ... 320	For bearing and end caps, corresponds to MS1 to ISO 15552	17
[2] Flange mounting FNG	160 ... 320	For bearing or end caps, corresponds to MF1/MF2 to ISO 15552	17
[3] Swivel flange SNG	160, 200	For end caps	18
[4] Clevis foot LSNG	160, 200	With spherical bearing	20
[5] Swivel flange SNGL	160, 200	For end cap, corresponds to MP2 to ISO 15552	19
[6] Swivel flange SNGB	160 ... 320	For end cap, corresponds to MP2 to ISO 15552	18
[7] Clevis foot LN/LNG	160 ... 320	For swivel flange SNGB	18
[8] Clevis foot LSN	160 ... 320	With spherical bearing	20
[9] Push-in fitting QS	160, 200	For connecting tubing with standard outside diameters	20
[10] Reducing nipple NPFC	160, 200	For connecting QS fittings with thread G1/2 to cylinders with thread G3/4	20
Reducing nipple D	250, 320	For connecting QS fittings with thread G1/2 to cylinders with thread G1	
[11] One-way flow control valve GRIA	160, 200	For speed regulation	grla
[12] Connecting cable NEBU	160 ... 320	-	21
[13] Proximity switch SME/SMT-8	160 ... 320	For sensing the piston position	21
[14] Sensor bracket DASP	160 ... 320	For proximity switch SME/SMT-8	22
[15] Rod eye SGS	160 ... 320	With spherical bearing	20
[16] Rod clevis SG	160 ... 320	Permits a swivelling movement of the cylinder in one plane	20
[17] Self-aligning rod coupler FK	160, 200	For compensating radial and angular deviations	20
[18] Rod clevis SGA	160, 200	Suitable for spherical mounting of cylinders in conjunction with rod eye SGS	20
[19] Position transmitter SDAT	160, 200	<ul style="list-style-type: none"> <li>Continuously senses the position of the piston</li> <li>Has an analogue output</li> </ul>	22
- Trunnion support LNZG	160 ... 320	For mounting the cylinder in combination with central swivel mounting or trunnion flange mounting position	19

## Standards-based cylinders DSBG, ISO 15552

### Type codes

<b>001</b>	<b>Series</b>	
<b>DSBG</b>	Standards-based cylinder, double-acting, based on ISO 15552	
<b>002</b>	<b>Central swivel mounting</b>	
	None	
<b>V</b>	Central, clamped	
<b>003</b>	<b>Piston diameter</b>	
<b>160</b>	160	
<b>200</b>	200	
<b>250</b>	250	
<b>320</b>	320	
<b>004</b>	<b>Stroke</b>	
<b>...</b>	25 ... 500	
<b>005</b>	<b>Piston rod type</b>	
	At one end	
<b>T</b>	Through piston rod	
<b>006</b>	<b>Piston rod thread type</b>	
	Male thread	
<b>F</b>	Female thread	
<b>007</b>	<b>Cushioning</b>	
<b>P</b>	Elastic cushioning rings/plates on both sides	
<b>PPV</b>	Pneumatic cushioning, adjustable at both ends	
<b>008</b>	<b>Position sensing</b>	
	None	
<b>A</b>	For proximity sensor	
<b>009</b>	<b>Standard</b>	
	Not according to standard	
<b>N3</b>	Conforms to ISO 15552	
<b>010</b>	<b>Corrosion protection</b>	
	Standard	
<b>R3</b>	High corrosion protection	
<b>011</b>	<b>Temperature range</b>	
	Standard	
<b>T1</b>	Heat-resistant seals max. 120°C	
<b>T4</b>	0 ... +150°C	
<b>012</b>	<b>Scraper variant</b>	
	None	
<b>A6</b>	Metal scraper	

<b>013</b>	<b>EU certification</b>	
	None	
<b>EX4</b>	II 2GD	
<b>014</b>	<b>Trunnion flange mounting position, positive locking</b>	
	None	
<b>...Y</b>	With	
<b>015</b>	<b>Piston rod extension</b>	
	None	
<b>...E</b>	1 ... 500 mm	
<b>016</b>	<b>Piston rod thread extension</b>	
<b>...L</b>	1 ... 70 mm	
<b>017</b>	<b>Piston rod thread shortening</b>	
	None	
<b>...S</b>	0 ... 86 mm	
<b>018</b>	<b>Piston rod thread</b>	
	Standard	
<b>M16</b>	M16	
<b>M16P</b>	M16x1.5	
<b>M20</b>	M20	
<b>M20P</b>	M20x1.5	
<b>M24</b>	M24	
<b>M27</b>	M27	
<b>M36P</b>	M36x2	
<b>M42P</b>	M42x2	
<b>M48</b>	M48	
<b>M42</b>	M42	
<b>M27P</b>	M27x2	
<b>M30P</b>	M30x2	
<b>M36</b>	M36	
<b>019</b>	<b>Integrated spacer bolts</b>	
	None	
<b>B1</b>	Both sides	
<b>B2</b>	In the bearing cover	
<b>B3</b>	In the end cap	
<b>020</b>	<b>Thread length of spacer bolts on bearing cap</b>	
	Without spacer bolt	
<b>...LB2</b>	20 ... 140 mm	
<b>021</b>	<b>Thread length of spacer bolts on end cap</b>	
	Without spacer bolt	
<b>...LB3</b>	20 ... 140 mm	

Data sheet

Function

Elastic cushioning

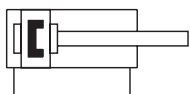

PPV cushioning

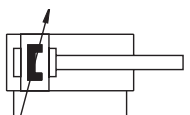

∅ - Diameter  
160 ... 320 mm

- | - Stroke length  
1 ... 2700 mm

www.festo.com

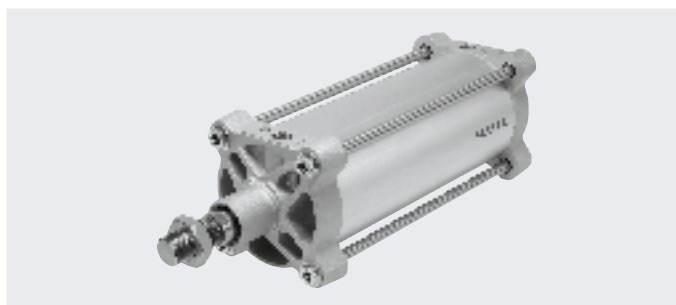

General technical data					
Piston diameter		160	200	250	320
Design	Piston/piston rod/cylinder barrel				
Mode of operation	Double-acting				
Pneumatic connection		G3/4	G3/4	G1	G1
Stroke <sup>1)</sup>					
DSBG-...	[mm]	1 ... 2700		1 ... 2250	
DSBG-...-...E	[mm]	1 ... 2000			
DSBG-...-...L	[mm]	1 ... 2000			
Cushioning					
DSBG-...-P	Elastic cushioning rings/pads at both ends				
DSBG-...-PPV	Pneumatic cushioning, adjustable at both ends				
Cushioning length	[mm]	48	55	65	
Position sensing	Via proximity switch				
Type of mounting	With female thread/accessories				
Mounting position	Any				

1) In combination with the position sensing option, the minimum stroke is 10 mm

Operating and environmental conditions					
Piston diameter		160	200	250	320
Operating medium	Compressed air to ISO 8573-1:2010 [7:4:4]				
Note on operating/pilot medium	Lubricated operation possible (in which case lubricated operation will always be required)				
Operating pressure	[bar]	0.6 ... 10			
Ambient temperature <sup>1)</sup>					
DSBG-...	[°C]	-20 ... +80			
DSBG-...-T1	[°C]	0 ... +120			
DSBG-...-T4	[°C]	0 ... +150		-	
DSBG-...-EX4	[°C]	-20 ... +60			
Corrosion resistance CRC					
DSBG-...		2 <sup>2)</sup>			
DSBG-...-R3		3 <sup>3)</sup>			

1) Note operating range of proximity switches

2) Corrosion resistance class CRC 2 to Festo standard FN 940070

Moderate corrosion stress. Indoor applications in which condensation can occur. External visible parts with primarily decorative surface requirements which are in direct contact with a normal industrial environment.

3) Corrosion resistance class CRC 3 to Festo standard FN 940070

High corrosion stress. Outdoor exposure under moderate corrosive conditions. External visible parts with primarily functional surface requirements which are in direct contact with a normal industrial environment.

## Standards-based cylinders DSBG, ISO 15552

### Data sheet

ATEX <sup>1)</sup>	
ATEX category for gas	II 2G
Type of ignition protection for gas	Ex h IIC T4 Gb
ATEX category for dust	II 2D
Type of ignition protection for dust	Ex h IIIC T120°C Db
Explosion-proof ambient temperature	-20°C ≤ Ta ≤ +60°C
CE marking (see declaration of conformity)	To EU Explosion Protection Directive (ATEX)
UKCA marking (see declaration of conformity)	To UK EX instructions
Explosion protection certification outside the EU	EPL Gb (GB)
	EPL Db (GB)

1) Note the ATEX certification of the accessories.

Forces [N] and impact energy [J]				
Piston diameter	160	200	250	320
Theoretical force at 6 bar, advancing	12064	18850	29452	48255
Theoretical force at 6 bar, retracting	11310	18096	28274	46385
Max. impact energy in the end positions				
DSBG-...	3.3	4.8	7.2	12.6
DSBG-...-T1/-T4	2.3	4	4.2	6

Permissible impact velocity: 
$$v = \sqrt{\frac{2 \cdot E}{m_1 + m_2}}$$

Maximum permissible mass: 
$$m_2 = \frac{2 \cdot E}{v^2} - m_1$$

V perm. impact velocity  
 E max. impact energy  
 m1 Moving mass (drive)  
 m2 Moving payload

Weights [g]				
Piston diameter	160	200	250	320
<b>DSBG-...</b>				
Product weight with 0 mm stroke	11751	15493	29313	50231
Additional weight per 10 mm stroke	208	246	384	623
Moving mass with 0 mm stroke	4292	5348	9978	16912
Moving mass per 10 mm stroke	97	97	157	249
<b>DSBG-...-T</b>				
Product weight with 0 mm stroke	13487	17356	31979	54775
Additional weight per 10 mm stroke	304	343	541	872
Moving mass with 0 mm stroke	6028	7210	12643	21455
Moving mass per 10 mm stroke	194	194	314	499

Data sheet

Max. transverse force  $F_q$  as a function of stroke length  $l$

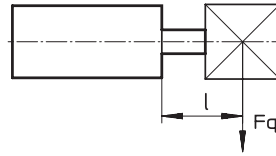
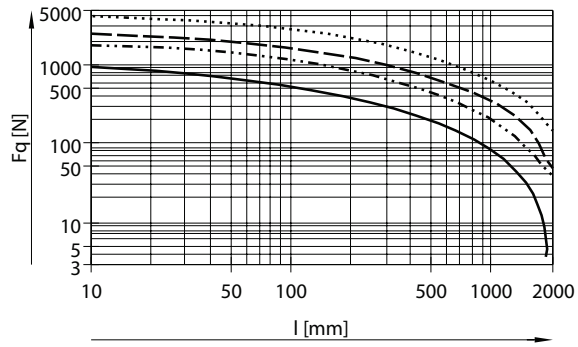

- Ø 160/200
- Ø 250
- Ø 320

Data sheet

**Materials**

Sectional view

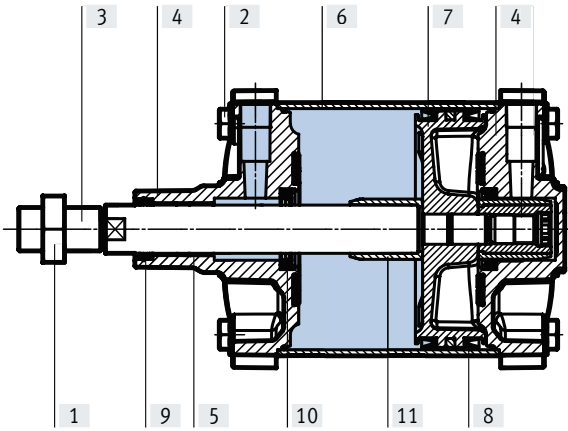

Normcilinder

[1]	Nut	
	DSBG-...	Galvanised steel
	DSBG-...-R3	High-alloy stainless steel
[2]	Collar nut	Galvanised steel
[3]	Piston rod	
	DSBG-...	Steel, high-alloy
	DSBG-...-R3	High-alloy stainless steel
	DSBG-...-A6	Hard-chrome-plated tempered steel
[4]	Cover	Coated die-cast aluminium
[5]	Bearing	
	DSBG-...	Metal polymer compound
	DSBG-...-EX4	Bronze
[6]	Cylinder barrel	Anodised wrought aluminium alloy
[7]	Piston	Coated die-cast aluminium
[8]	Piston seal	
	DSBG-...	NBR
	DSBG-...-T1/-T4	FPM
[9]	Piston rod wiper seal	
	DSBG-...	NBR
	DSBG-...-T1/-T4	FPM
[10]	Buffer seal	
	DSBG-...	POM
	DSBG-...-T1/-T4	Wrought aluminium alloy
[11]	Cushion piston	
	DSBG-...	POM
	DSBG-...-T1/-T4	Wrought aluminium alloy
-	Tie rods	
	DSBG-...	Steel, high-alloy
	DSBG-...-R3	High-alloy stainless steel
	Rod wiper seal	
	DSBG-...-A6	CuZn
	Spacer bolt	
	DSBG-...-B1/-B2/-B3/-LB2/-LB3	High-alloy steel
	DSBG-...-R3-B1/-R3-B2/-R3-B3/-R3-LB2/-R3-LB3	High-alloy stainless steel
	Swivel mounting	
	DSBG-160/200-...-V/-...V	Painted spheroidal graphite cast iron
	DSBG-250/320-...-Y/-...Y	Galvanised steel
	Collar nut	Galvanised steel
	Note on materials	
	DSBG-...	RoHS-compliant
	DSBG-...-T4	Contains paint-wetting impairment substances



Data sheet

Dimensions

Download CAD data → [www.festo.com](http://www.festo.com)

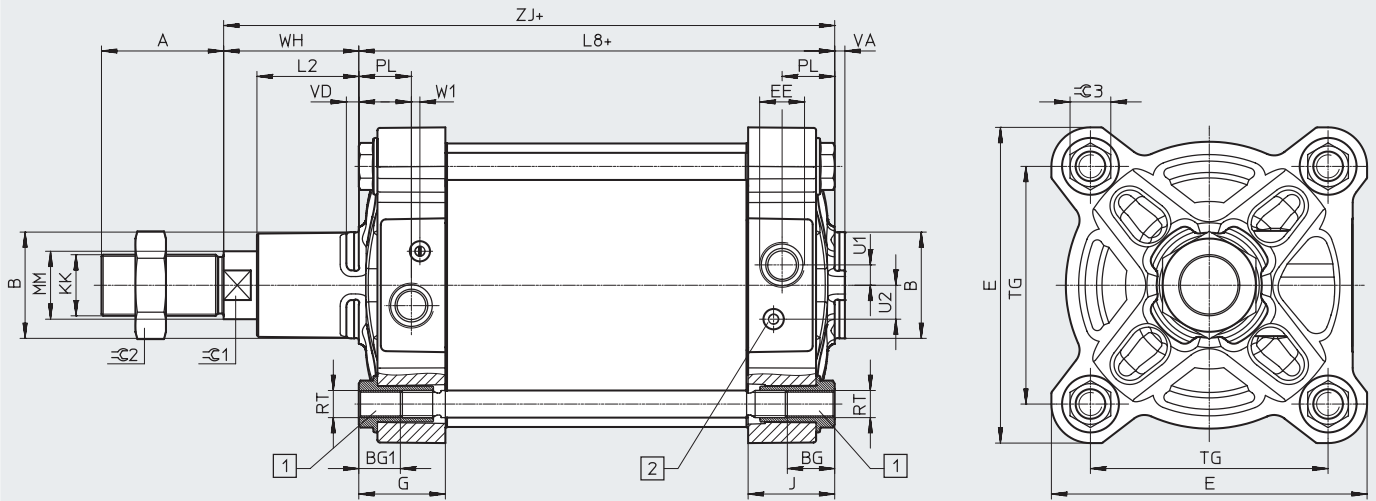

+ = plus stroke length

[1] Special outer hex nut with female thread for mounting components

[2] Adjusting screw for adjustable end-position cushioning (PPV)

∅	A	B ∅	BG	BG1	E	EE	G	J
[mm]	-0.5	d11	min.	±0.5	±0.9			
160	72	65	24	25	186	G3/4	50.7	50.7
200	72	75	24	25	230	G3/4	46.9	46.7
250	84	90	25	26	284	G1	51.2	51.2
320	96	110	28	29	347	G1	58.2	58.2

∅	L2	L8	MM	PL	RT	TG	U1	U2
[mm]						±1.1		
160	60	180±1	40	31	M16	140	12	20
200	70	180±1.2	40	30	M16	175	12	20
250	80	200±1.6	50	32	M20	220	25	25
320	90	220±2.2	63	37.5	M24	270	25	25

∅	VA	VD	W1	WH	ZJ	∅C1	∅C2	∅C3
[mm]	-1				±1			
160	6	7	5	80±1.3	260	36	55	24 <sub>h13</sub>
200	6	6.5	5	95±1.4	275	36	55	24 <sub>h13</sub>
250	10	13.7	3	105±1.5	305	46	65	41 <sub>h14</sub>
320	10	10.7	1.5	120±1.5	340	55	75	50 <sub>h14</sub>

∅	KK	
	DSBG...	-M... <sup>1)</sup>
[mm]		
160	M36x2	M16/M16x1.5/M20/M20x1.5/M24/M27/M27x2/M30x2/M36
200	M36x2	M20/M20x1.5/M24/M27/M27x2/M30x2/M36
250	M42x2	M24/M27/M27x2/M30x2/M36x2/M42
320	M48x2	M27/M27x2/M30x2/M36x2/M42x2/M48

1) Threads with smaller nominal diameter than in the basic version can generally not withstand such high loads. If necessary, the screw connection must be engineered.

Data sheet

**Dimensions – Variants**

Download CAD data → [www.festo.com](http://www.festo.com)

T – Through piston rod

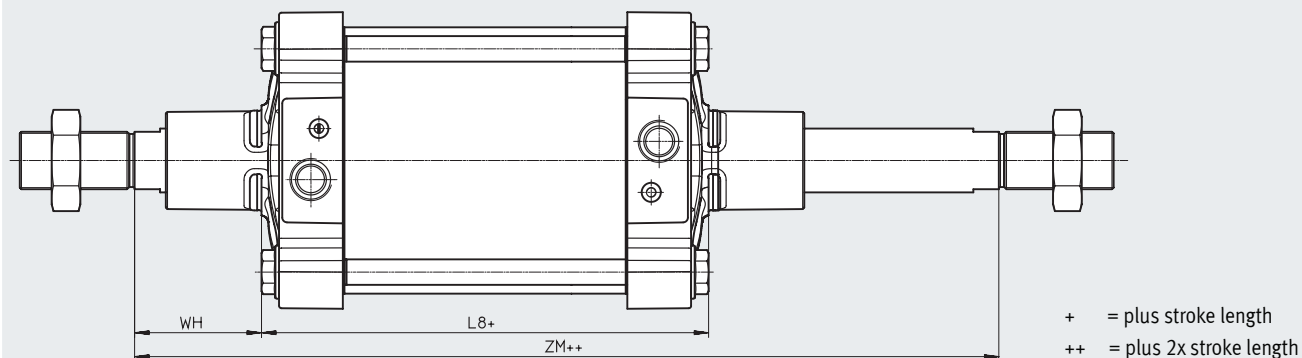

∅	L8	WH	ZM
[mm]			
160	180±1.1	80±1.3	342±1
200	180±1	95±1.4	372±1.2
250	200±1	105±1.5	410±1.6
320	220±2.2	120±1.5	462±1

Data sheet

F – Female thread

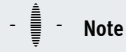
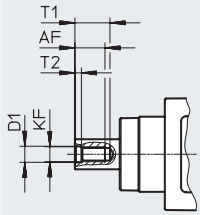

**Note**  
Female thread at both ends in combination with the variant T.

...E – Extended piston rod

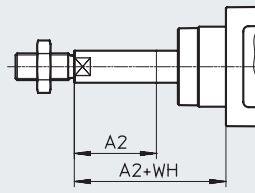

**Note**  
Piston rod thread is extended at one end in combination with the variant T.

...L – Extended piston rod thread

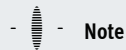
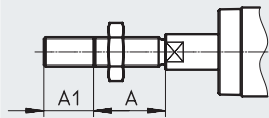

**Note**  
Piston rod thread is extended at both ends in combination with variant T.

...S – Shortened piston rod thread

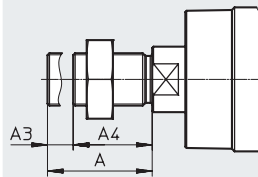

**Note**  
Piston rod is shortened at both ends in combination with variant T.

Effective thread length:  $A4 = A - A3$

∅	A	A1		A2		A3	
		min.	max.	min.	max.	min.	max.
160	72	1	70	1	500	1	62
200	72	1	70	1	500	1	62
250	84	1	100	1	500	1	74
320	96	1	100	1	500	1	86

∅	AF	D1	KF	T1	T2	WH
[mm]		H9				
160	36	25	M24	40	10	80±1.3
200	36	25	M24	40	10	95±1.4
250	50	31	M30	60	10	105±1.5
320	55	37	M36	65	13	120±1.5

Data sheet

**Dimensions – Variants**

Download CAD data → [www.festo.com](http://www.festo.com)

V – Central swivel mounting

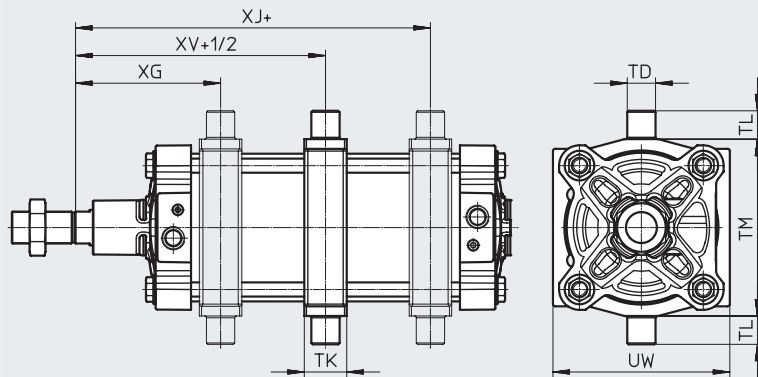

- **Note**

The swivel mounting is mounted centrally on delivery but can be moved at any time.

+ = plus stroke length  
+1/2 = plus half stroke length

∅	TD	TK	TL	TM	UW	XG	XJ	XV
[mm]	∅ e8		h14	h14		±0.5	±0.5	
160	32	48	32	200	200	157.5	182.5	170
200	32	48	32	250	240	169	200.5	185

...Y – Trunnion flange mounting position

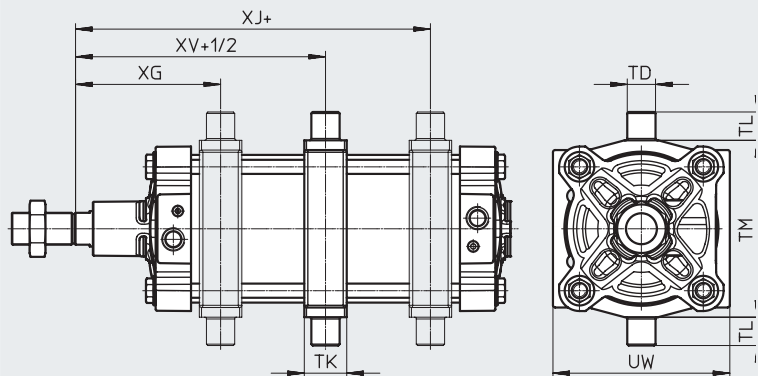

- **Note**

The dimensions for the trunnion flange mounting position (...Y) refer to the basic design without extended piston rod thread.

The swivel mounting has a positive-locking screw connection. This means that the position cannot be changed at a later date.

+ = plus stroke length  
+1/2 = plus half stroke length

∅	TD	TK	TL	TM	UW	XG	XJ	XV
[mm]	∅ e8		h14	h14		±2.4	±2.4	±2.4
250	40	60	40	320	319	198	209	205
320	50	70	50	400	385	226	233	230

Data sheet

**Dimensions – Variants**

Download CAD data → [www.festo.com](http://www.festo.com)

B1/B2/B3 – Integrated spacer bolt

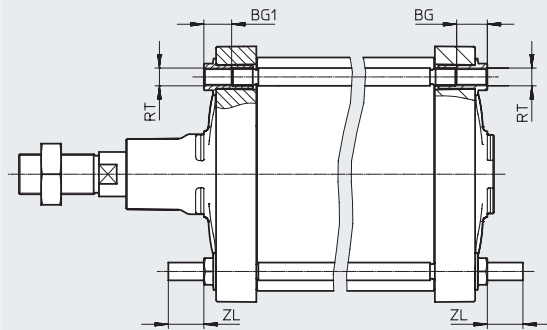

∅	BG	BG1	RT	ZL	ZL1 <sup>1)</sup>
[mm]	min.	±0.5		±0.5	
160	24	25	M16	32	32
200	24	25	M16	32	32
250	25	26	M20	40	40
320	28	29	M24	50	50

1) Tolerances depending on variant:  
B1: ZL1 = +1/-2; B3: ZL1 = ±0.5

...LB2/-LB3 – Thread length of spacer bolts

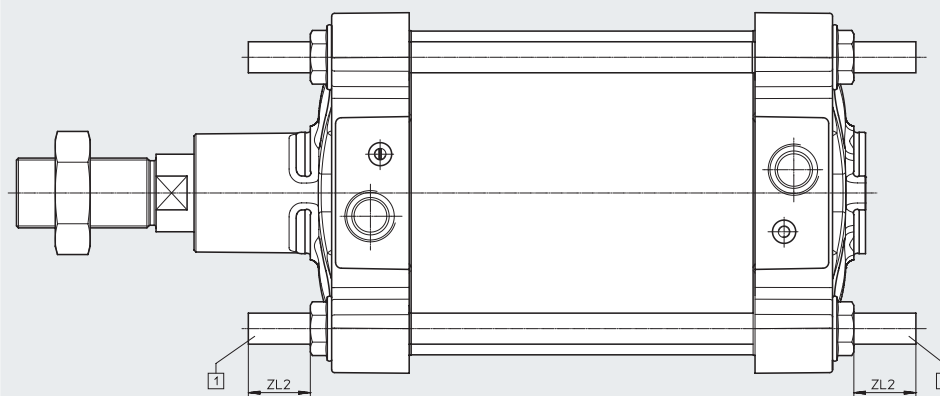

[1] = DSBG-...-LB2 (on the bearing cap)  
[2] = DSBG-...-LB3 (on the end cap)

∅	ZL2	
	min.	max.
160	32	140
200	32	140
250	40	140
320	50	140

Standards-based cylinders DSBG, ISO 15552

Data sheet

Ordering data					
Piston diameter [mm]	Stroke [mm]	With PPV cushioning With position sensing		With elastic cushioning Without position sensing	
		Part no.	Type	Part no.	Type
160	25	2029462	DSBG-160-25-PPVA-N3	2536747	DSBG-160-25-P-N3
	40	2029463	DSBG-160-40-PPVA-N3	2536748	DSBG-160-40-P-N3
	50	2029464	DSBG-160-50-PPVA-N3	2536749	DSBG-160-50-P-N3
	80	2029465	DSBG-160-80-PPVA-N3	2536750	DSBG-160-80-P-N3
	100	2029466	DSBG-160-100-PPVA-N3	2536751	DSBG-160-100-P-N3
	125	2029467	DSBG-160-125-PPVA-N3	2536752	DSBG-160-125-P-N3
	160	2029468	DSBG-160-160-PPVA-N3	2536753	DSBG-160-160-P-N3
	200	2029469	DSBG-160-200-PPVA-N3	2536754	DSBG-160-200-P-N3
	250	2029470	DSBG-160-250-PPVA-N3	2536755	DSBG-160-250-P-N3
	320	2029471	DSBG-160-320-PPVA-N3	2536756	DSBG-160-320-P-N3
	400	2029472	DSBG-160-400-PPVA-N3	2536758	DSBG-160-400-P-N3
	500	2029473	DSBG-160-500-PPVA-N3	2536759	DSBG-160-500-P-N3
	1 ... 2700 <sup>1)</sup>	2035926	DSBG-160-...-PPVA-N3	2537196	DSBG-160-...-P-N3
200	25	2390139	DSBG-200-25-PPVA-N3	2537448	DSBG-200-25-P-N3
	40	2390140	DSBG-200-40-PPVA-N3	2537449	DSBG-200-40-P-N3
	50	2390141	DSBG-200-50-PPVA-N3	2537450	DSBG-200-50-P-N3
	80	2390142	DSBG-200-80-PPVA-N3	2537451	DSBG-200-80-P-N3
	100	2390143	DSBG-200-100-PPVA-N3	2537452	DSBG-200-100-P-N3
	125	2390144	DSBG-200-125-PPVA-N3	2537454	DSBG-200-125-P-N3
	160	2390145	DSBG-200-160-PPVA-N3	2537455	DSBG-200-160-P-N3
	200	2390146	DSBG-200-200-PPVA-N3	2537456	DSBG-200-200-P-N3
	250	2390147	DSBG-200-250-PPVA-N3	2537457	DSBG-200-250-P-N3
	320	2390148	DSBG-200-320-PPVA-N3	2537458	DSBG-200-320-P-N3
	400	2390149	DSBG-200-400-PPVA-N3	2537459	DSBG-200-400-P-N3
	500	2390150	DSBG-200-500-PPVA-N3	2537460	DSBG-200-500-P-N3
	1 ... 2700 <sup>1)</sup>	2389803	DSBG-200-...-PPVA-N3	2537445	DSBG-200-...-P-N3
250	1 ... 2250 <sup>1)</sup>	2865078	DSBG-250-...-PPVA-N3	2865145	DSBG-250-...-P-N3
320	1 ... 2250 <sup>1)</sup>	3150987	DSBG-320-...-PPVA-N3	3178601	DSBG-320-...-P-N3

1) In combination with the position sensing option, the minimum stroke is 10 mm.

 **Note**

Other variants in the modular product system → page 15

## Ordering data – Modular product system

Ordering table							
Size	160	200	250	320	Conditions	Code	Enter code
Module no.	<b>2036032</b>	<b>2344936</b>	<b>2732003</b>	<b>2776472</b>			
Function	Standards-based cylinder, double-acting, based on ISO 15552					<b>DSBG</b>	DSBG
Central swivel mounting	None						
	Centrally clamped		–			<b>-V</b>	
Piston diameter [mm]	160	200	250	320		<b>-...</b>	
Stroke [mm]	1 ... 2700		1 ... 2250		[1]	<b>-...</b>	
Piston rod type	At one end						
	Through piston rod					<b>-T</b>	
Piston rod thread type	Male thread						
	Female thread				[2]	<b>-F</b>	
Cushioning	Elastic cushioning rings/pads at both ends					<b>-P</b>	
	Pneumatic cushioning, adjustable at both ends					<b>-PPV</b>	
Position sensing	None						
	Via proximity switch					<b>A</b>	
Standard	Corresponds to ISO 15552					<b>-N3</b>	
Corrosion protection	Standard						
	High corrosion protection				[3]	<b>R3</b>	
Temperature range	Standard						
	[°C]	Heat-resistant seals up to max. 120					<b>T1</b>
	[°C]	0 ... +150		–	[4]	<b>T4</b>	
Scraper variant	None						
	Metal scraper		–			<b>A6</b>	
EU certification	None						
	II 2GD				[45]	<b>EX4</b>	
Trunnion flange mounting position [mm]	None						
	–		198 ... 2459	226 ... 2483	[6]	<b>-...Y</b>	

- [1] ... In combination with the position sensing option A, the minimum stroke is 10 mm  
 [2] F Not with N3, ...L, M...  
 [3] R3 Not with V, ...Y  
 [4] T4 Not with A6  
 [5] EX4 Not with V, P, T1, T4, B1, B2, B3, ...LB2, ...LB3  
 [6] ...Y Not with ...LB2, ...LB3

Ordering data – Modular product system

Ordering table		160	200	250	320	Conditions	Code	Enter code	
Size									
Extended piston rod	[mm]	None							
		1 ... 500				[7]	-...E		
Extended piston rod thread	[mm]	None							
		1 ... 70		1 ... 100		[7]	-...L		
Shortened piston rod thread	[mm]	None							
		1 ... 62		1 ... 74	1 ... 86		-...S		
Piston rod thread		Standard (→ 9)							
		M16		-		[9]	-M16		
		M16x1.5		-		[9]	-M16P		
		M20		-		[9]	-M20		
		M20x1.5		-		[9]	-M20P		
		M24		-		[9]	-M24		
		M27		-		[9]	-M27		
		M27x2		-		[9]	-M27P		
		M30x2		-		[9]	-M30P		
		M36		-		[9]	-M36		
		M36x2		-		[9]	-M36P		
		-		M42		-	[9]	-M42	
		-		M42x2		-	[9]	-M42P	
-		-		M48	[9]	-M48			
Integrated spacer bolts		None							
		At both ends				[8] [9]	-B1		
		On the bearing cap				[8] [9]	-B2		
		On the end cap				[8] [9]	-B3		
Thread length of spacer bolts	[mm]	None							
		On the bearing cap				[9]	-...LB2		
		32 ... 140		40 ... 140	50 ... 140				
		On the end cap				[9]	-...LB3		
32 ... 140		40 ... 140	50 ... 140						

- [7] ...E, ...L      Only up to stroke 2000 mm.  
Not with N3
- [8] B1, B2, B3      Not with ...LB2, ...LB3
- [9] M..., B..., LB...      Not with N3

 - **Note**  
If a thread smaller than the standard thread is selected for feature M... (piston rod thread), this may reduce the load capacity.

 - **Note**  
When characteristic M... is selected, the piston rod nut is not included.



**Accessories**

**Foot mounting HNG**

Material:  
Galvanised steel  
Free of copper and PTFE

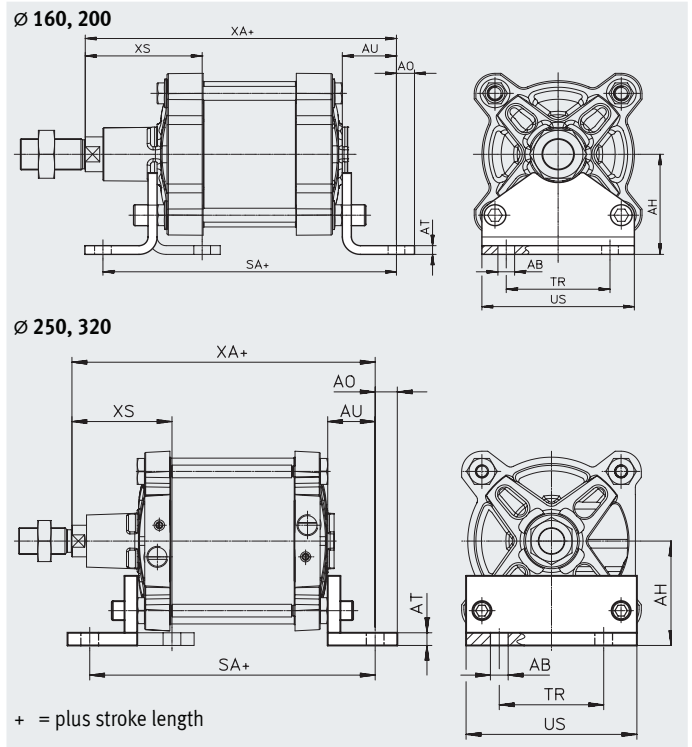

Dimensions and ordering data														
For diameter [mm]	AB Ø	AH	AO	AT	AU	SA	TR	US	XA	XS	CRC <sup>1)</sup>	Weight [g]	Part no.	Type
160	18.5	115	20	10	60	300	115	169	320	130	2	3931	<b>34476</b>	<b>HNG-160</b>
200	24	135	30	12	70	320	135	214	345	153	2	6896	<b>34477</b>	<b>HNG-200</b>
250	28	165	35	20	75	350	165	270	380	160	2	17084	<b>157510</b>	<b>HNG-250</b>
320	35	200	40	25	85	390	200	340	425	180	2	29968	<b>157511</b>	<b>HNG-320</b>

1) Corrosion resistance class CRC 2 to Festo standard FN 940070  
Moderate corrosion stress. Indoor applications in which condensation can occur. External visible parts with primarily decorative surface requirements which are in direct contact with a normal industrial environment.

**Flange mounting FNG**

Material:  
Painted spheroidal graphite cast iron  
Free of copper and PTFE  
RoHS-compliant

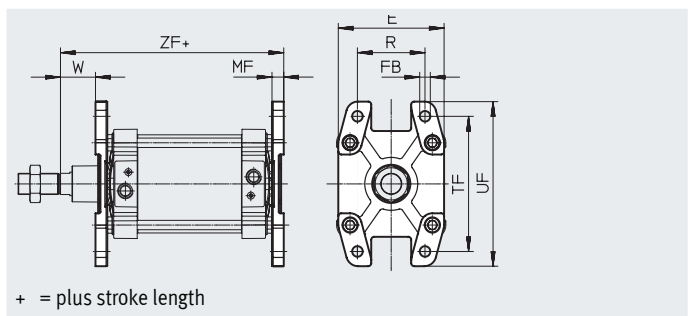
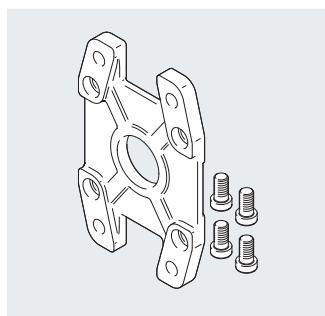

Dimensions and ordering data													
For diameter [mm]	E	FB Ø H13	MF	R	TF	UF	W	ZF	CRC <sup>1)</sup>	Weight [g]	Part no.	Type	
160	<b>180</b>	<b>18</b>	<b>20</b>	<b>115</b>	<b>230</b>	<b>280</b>	<b>60</b>	<b>280</b>	1	3550	<b>34478</b>	<b>FNG-160</b>	
200	<b>220</b>	<b>22</b>	<b>25</b>	<b>135</b>	<b>270</b>	<b>320</b>	<b>70</b>	<b>300</b>	1	5321	<b>34479</b>	<b>FNG-200</b>	
250	<b>270</b>	<b>26</b>	<b>25</b>	<b>165</b>	<b>330</b>	<b>390</b>	<b>80</b>	<b>330</b>	1	8657	<b>157508</b>	<b>FNG-250</b>	
320	<b>340</b>	<b>33</b>	<b>30</b>	<b>200</b>	<b>400</b>	<b>470</b>	<b>90</b>	<b>370</b>	1	15109	<b>157509</b>	<b>FNG-320</b>	

1) Corrosion resistance class CRC 1 to Festo standard FN 940070  
Low corrosion stress. Dry internal application or transport and storage protection. Also applies to parts behind covers, in the non-visible interior area, and parts which are covered in the application (e.g. drive trunnions).

Standards-based cylinders DSBG, ISO 15552

Accessories

**Swivel flange SNG**

Material:  
Die-cast aluminium  
Free of copper and PTFE  
RoHS-compliant

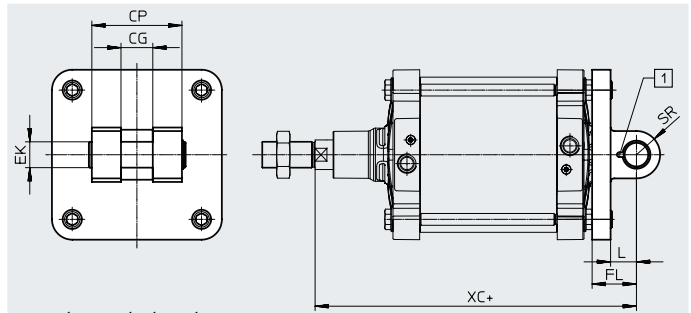

+ = plus stroke length

[1] The pivot pin is secured against rotation with a spring pin.

**Dimensions and ordering data**

For diameter [mm]	CG	CP	EK $\varnothing$ F7 h9	FL $\pm 0.2$	L	SR	XC	CRC <sup>1)</sup>	Weight [g]	Part no.	Type
160	H14	d12	35	55	35	max.	315	2	3577	<b>152597</b>	<b>SNG-160</b>
200	H14	d12	35	60	35	max.	335	2	5160	<b>152598</b>	<b>SNG-200</b>

1) Corrosion resistance class CRC 2 to Festo standard FN 940070

Moderate corrosion stress. Indoor applications in which condensation can occur. External visible parts with primarily decorative surface requirements which are in direct contact with a normal industrial environment.

**Swivel flange SNGB**

Material:  
 $\varnothing 160$ : Die-cast aluminium  
 $\varnothing 200$ : Galvanised steel  
 $\varnothing 250/320$ : Spheroidal graphite cast iron  
Free of copper and PTFE  
RoHS-compliant

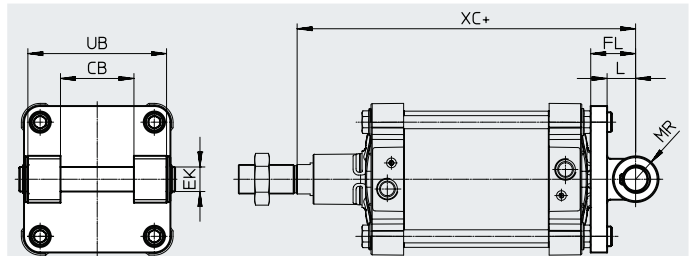

+ = plus stroke length

**Dimensions and ordering data**

For diameter [mm]	CB $\varnothing$ H14	EK $\varnothing$ E10	FL $\pm 0.2$	L	MR	UB h14	XC	CRC <sup>1)</sup>	Weight [g]	Part no.	Type
160	90	30	55	37	30	170	315	2	3445	<b>34547</b>	<b>SNGB-160</b>
200	90	30	60	40	25	170	335	2	10020	<b>562455</b>	<b>SNGB-200-B</b>
250	110	40	70	47	40	200	375	1	16141	<b>157512</b>	<b>SNGB-250</b>
320	120	45	80	52	45	220	420	1	26636	<b>157513</b>	<b>SNGB-320</b>

1) Corrosion resistance class CRC 1 to Festo standard FN 940070

Low corrosion stress. Dry internal application or transport and storage protection. Also applies to parts behind covers, in the non-visible interior area, and parts which are covered in the application (e.g. drive trunnions).

Corrosion resistance class CRC 2 to Festo standard FN 940070

Moderate corrosion stress. Indoor applications in which condensation can occur. External visible parts with primarily decorative surface requirements which are in direct contact with a normal industrial environment.

**Accessories**

**Swivel flange SNGL**

Material:  
Die-cast aluminium  
Free of copper and PTFE

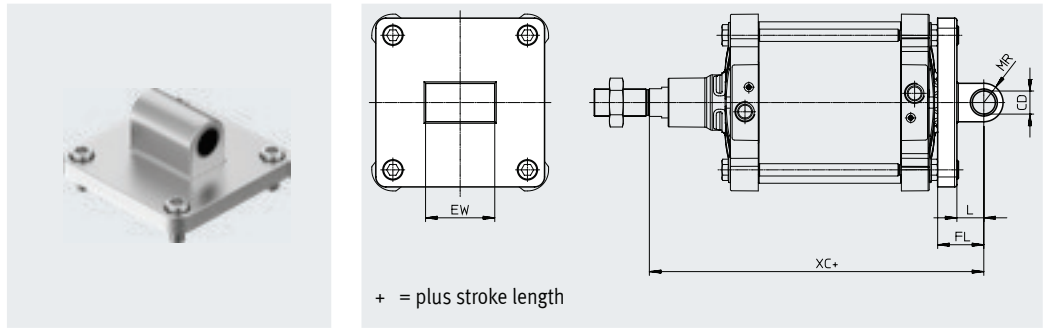

Dimensions and ordering data										
For diameter [mm]	CD ∅ H9	EW -0.5/-1.2	FL ±0.2	L	MR	XC	CRC <sup>1)</sup>	Weight [g]	Part no.	Type
160	30	90	55	35	25	315	2	2358	<b>151534</b>	<b>SNGL-160</b>
200	30	90	60	35	25	335	2	3713	<b>151535</b>	<b>SNGL-200</b>

1) Corrosion resistance class CRC 2 to Festo standard FN 940070  
Moderate corrosion stress. Indoor applications in which condensation can occur. External visible parts with primarily decorative surface requirements which are in direct contact with a normal industrial environment.

**Trunnion support LNZG**

Material:  
Mounting: Galvanised steel  
Plain bearing: Plastic  
Free of copper and PTFE  
RoHS-compliant

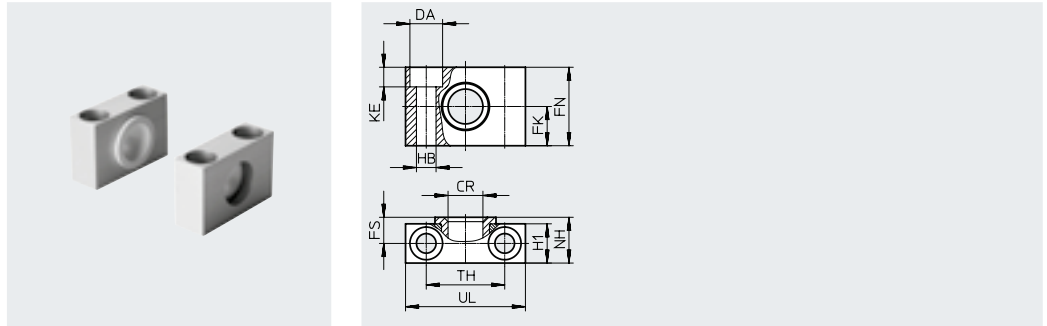



Dimensions and ordering data									
For diameter [mm]	CR ∅	DA ∅ H13	FK ∅ ±0.2	FN	FS	H1	HB ∅ H13	KE	
160, 200	32 <sup>D11</sup>	26	30	60	22.5	36	18	17	
250	40 <sup>G7</sup>	33	35	70	27.5	45	22	21.5	
320	50 <sup>G7</sup>	40	40	80	32.5	55	26	25.5	

For diameter [mm]	NH	TH ±0.3	UL	CRC <sup>1)</sup>	Weight [g]	Part no.	Type
160, 200	40	60	92	2	659	<b>35780</b>	<b>LNZG-16 0/200</b>
250	50	90	140	2	2218	<b>157516</b>	<b>LNZG-250</b>
320	60	100	150	2	2934	<b>157517</b>	<b>LNZG-320</b>

1) Corrosion resistance class CRC 2 to Festo standard FN 940070  
Moderate corrosion stress. Indoor applications in which condensation can occur. External visible parts with primarily decorative surface requirements which are in direct contact with a normal industrial environment.

### Accessories



#### Ordering data – Mounting components

Designation	For diameter	Part no.	Type
<b>Clevis foot LN/LNG</b>			
	160	<b>9037</b>	<b>LN-160</b>
	200	<b>33898</b>	<b>LNG-200</b>
	250	<b>9039</b>	<b>LN-250</b>
	320	<b>9040</b>	<b>LN-320</b>
<b>Clevis foot LSNG</b>			
	160	<b>152599</b>	<b>LSNG-160</b>
	200	<b>152600</b>	<b>LSNG-200</b>

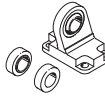
Data sheets → Internet: mounting component

Designation	For diameter	Part no.	Type
<b>Clevis foot LSN</b>			
	160	<b>6988</b>	<b>LSN-160</b>
	200	<b>6989</b>	<b>LSN-200</b>
	250	<b>6990</b>	<b>LSN-250</b>
	320	<b>6991</b>	<b>LSN-320</b>

#### Ordering data – Piston rod attachments

Designation	For diameter	Part no.	Type
<b>Rod eye SGS</b>			
	160, 200	<b>10775</b>	<b>SGS-M36x2</b>
	250	<b>10776</b>	<b>SGS-M42x2</b>
	320	<b>10777</b>	<b>SGS-M48x2</b>
<b>Rod eye SG</b>			
	160, 200	<b>9581</b>	<b>SG-M36x2</b>
	250	<b>9582</b>	<b>SG-M42x2</b>
	320	<b>9583</b>	<b>SG-M48x2</b>

Data sheets → Internet: piston rod attachment

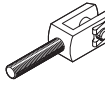
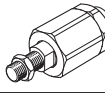
Designation	For diameter	Part no.	Type
<b>Rod clevis SGA</b>			
	160, 200	<b>10771</b>	<b>SGA-M36x2</b>
<b>Self-aligning rod coupler FK</b>			
	160, 200	<b>10746</b>	<b>FK-M36x2</b>

#### Ordering data – Push-in fittings

	For diameter	Connection		Part no.	Type	PE <sup>1)</sup>
		Thread	Tubing O.D.			
<b>G thread with external hexagon</b>						
	160, 200	G3/4	22	<b>8040613</b>	<b>QS-G3/4-22</b>	1

Data sheets → Internet: qs

1) Packaging unit

#### Ordering data – Reducing nipple



	For diameter	Description	Part no.	Type	PE <sup>1)</sup>
	<b>Reducing nipple NPFC</b>				
	160, 200	For connecting QS fittings with thread G1/2 to cylinders with thread G3/4	<b>8030313</b>	<b>NPFC-R-G34-G12-MF</b>	1
<b>Reducing nipple D</b>					
	250, 320	For connecting QS fittings with thread G1/2 to cylinders with thread G1	<b>197634</b>	<b>D-1/2I-1A</b>	1

1) Packaging unit

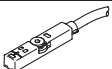
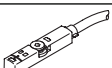
## Accessories

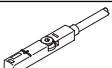
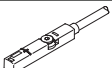
Ordering data – Proximity switch for T-slot, magneto-resistive						Data sheets → Internet: smt
	Type of mounting	Switching output	Electrical connection	Cable length [m]	Part no.	Type
<b>N/O contact</b>						
	Inserted in the slot from above, flush with the cylinder profile, short design	PNP	Cable, 3-wire	2.5	574335	SMT-8M-A-PS-24V-E-2.5-OE
			Plug M8x1, 3-pin	0.3	574334	SMT-8M-A-PS-24V-E-0.3-M8D
		NPN	Plug M12x1, 3-pin	0.3	574337	SMT-8M-A-PS-24V-E-0.3-M12
			Cable, 3-wire	2.5	574338	SMT-8M-A-NS-24V-E-2.5-OE
			Plug M8x1, 3-pin	0.3	574339	SMT-8M-A-NS-24V-E-0.3-M8D
<b>N/C contact</b>						
	Inserted in the slot from above, flush with the cylinder profile, short design	PNP	Cable, 3-wire	7.5	574340	SMT-8M-A-PO-24V-E-7.5-OE

Ordering data – Proximity switches for T-slot, magnetic reed						Data sheets → Internet: sme
	Type of mounting	Switching output	Electrical connection	Cable length [m]	Part no.	Type
<b>N/O contact</b>						
	Inserted in the slot from above, flush with the cylinder profile	Contacting	Cable, 3-wire	2.5	543862	SME-8M-DS-24V-K-2.5-OE
			5.0	543863	SME-8M-DS-24V-K-5.0-OE	
			Cable, 2-wire	2.5	543872	SME-8M-ZS-24V-K-2.5-OE
			Plug M8x1, 3-pin	0.3	543861	SME-8M-DS-24V-K-0.3-M8D
<b>N/C contact</b>						
	Inserted in the slot from above, flush with the cylinder profile	Contacting	Cable, 3-wire	7.5	546799	SME-8M-DO-24V-K-7.5-OE

Ordering data – Connecting cables						Data sheets → Internet: nebu
	Electrical connection, left	Electrical connection, right	Cable length [m]	Part no.	Type	
	Straight socket, M8x1, 3-pin	Cable, open end, 3-wire	2.5	541333	NEBU-M8G3-K-2.5-LE3	
			5	541334	NEBU-M8G3-K-5-LE3	
	Straight socket, M12x1, 5-pin	Cable, open end, 3-wire	2.5	541363	NEBU-M12G5-K-2.5-LE3	
			5	541364	NEBU-M12G5-K-5-LE3	
	Angled socket, M8x1, 3-pin	Cable, open end, 3-wire	2.5	541338	NEBU-M8W3-K-2.5-LE3	
			5	541341	NEBU-M8W3-K-5-LE3	
	Angled socket, M12x1, 5-pin,	Cable, open end, 3-wire	2.5	541367	NEBU-M12W5-K-2.5-LE3	
			5	541370	NEBU-M12W5-K-5-LE3	

Accessories

**Position transmitter**

The position transmitter continuously senses the position of the piston.

It has an analogue output with an output signal in proportion to the piston position.

**Ordering data – Position transmitter for T-slot**

Data sheets → Internet: position transmitter

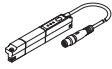
	For diameter	Position measuring range	Analogue output [mA]	Type of mounting	Electrical connection	Cable length [m]	Part no.	Type
	160, 200	0 ... 50	4 ... 20	Inserted in the slot from above	Plug M8x1, 4-pin, in-line	0.3	<b>1531265</b>	<b>SDAT-MHS-M50-1L-SA-E-0.3-M8</b>
		0 ... 80					<b>1531266</b>	<b>SDAT-MHS-M80-1L-SA-E-0.3-M8</b>
		0 ... 100					<b>1531267</b>	<b>SDAT-MHS-M100-1L-SA-E-0.3-M8</b>
		0 ... 125					<b>1531268</b>	<b>SDAT-MHS-M125-1L-SA-E-0.3-M8</b>
		0 ... 160					<b>1531269</b>	<b>SDAT-MHS-M160-1L-SA-E-0.3-M8</b>

**Ordering data – Connecting cables**

Data sheets → Internet: nebu

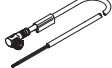
	Electrical connection, left	Electrical connection, right	Cable length [m]	Part no.	Type
	Straight socket, M8x1, 4-pin	Cable, open end, 4-wire	2.5	<b>541342</b>	<b>NEBU-M8G4-K-2.5-LE4</b>
			5	<b>541343</b>	<b>NEBU-M8G4-K-5-LE4</b>
	Angled socket, M8x1, 4-pin	Cable, open end, 4-wire	2.5	<b>541344</b>	<b>NEBU-M8W4-K-2.5-LE4</b>
			5	<b>541345</b>	<b>NEBU-M8W4-K-5-LE4</b>

**Ordering data – Sensor bracket for proximity switches**

	For diameter	Materials	Part no.	Type
	160, 200	Rail: anodised wrought aluminium alloy Screws: high-alloy stainless steel	<b>1553813</b>	<b>DASP-M4-160-A</b>
	250		<b>1456781</b>	<b>DASP-M4-250-A</b>
	320		<b>3015256</b>	<b>DASP-M4-320-A</b>