

Linear drives DGC

FESTO



Linear drives DGC

Key features

General information

- Compact – fitting length relative to stroke
- Loads and devices can be directly mounted on the slide
- Three types of cushioning available:
 - Elastic cushioning
 - Pneumatic cushioning
 - Hydraulic cushioning
- All settings accessible from one side:
 - Precision end-position adjustment
 - Position of proximity sensors
 - Mounting of drive
 - Speed regulation
 - Pneumatic end-position cushioning
- Optional: NSF-H1 lubricant for the food industry

The linear drive is of limited suitability for the food industry. More information on suitability for use in the food industry → Manufacturer's declaration.

Not approved for use in the food industry are:

- DGC-...-GP (protected version)
- DGC-... with integrated shock absorbers

- Sealing system

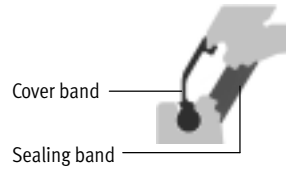

Advantages of the sealing system:

- Long strokes with no restrictions
- Virtually no leakage

Wide choice of variants

Compact design DGC-K



- Piston \varnothing 18 ... 80 mm
- Stroke lengths from 1 ... 8,500 mm
- 30% narrower than the DGC-G
- Low moving dead weight
- Symmetrical design

Basic design DGC-G



- Piston \varnothing 8 ... 63 mm
- Stroke lengths from 1 ... 8,500 mm
- Guide backlash = 0.2 mm
- For small loads
- Operating behaviour with torque load = average

Plain-bearing guide DGC-GF



- Piston \varnothing 18 ... 63 mm
- Stroke lengths from 1 ... 8,500 mm
- Guide backlash = 0.05 mm
- For small and medium loads
- Operating behaviour with torque load = average

Recirculating ball bearing guide DGC-KF



- Piston \varnothing 8 ... 63 mm
- Stroke lengths from 1 ... 8,500 mm
- Guide backlash = 0 mm
- For medium and large loads
- Precision mounting interface with stainless steel slide
- Operating behaviour under torque load = very good

Heavy-duty guide DGC-HD

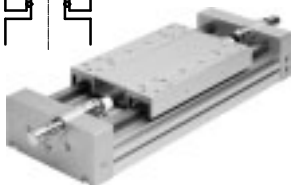

- Piston \varnothing 18, 25, 40 mm
- Stroke lengths from 10 ... 5,000 mm
- Guide backlash = 0 mm
- For large loads
- Operating behaviour under torque load = very good

Passive guide axis DGC-FA



- Without drive
- Piston \varnothing 8 ... 63 mm
- Stroke lengths from 1 ... 8,500 mm
- Guide backlash = 0 mm
- Precision guide, suitable for the DGC-KF. Can be used as a machine component or as a twin guide with the DGC-KF

Linear drives DGC

Key features

Versatile

1 Supply ports

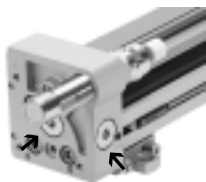

- Options on two sides (on the end face or at the front)
- For DGC-G/DGC-GF/DGC-KF

2 Proximity sensor G/H/I/J

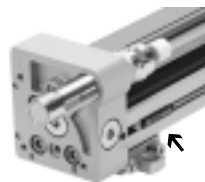

- Proximity sensors can be integrated, which means there is no projection. Cable can be guided through the slot behind a second sensor
- For DGC-G/DGC-GF/DGC-KF

3 Precision end-position adjustment

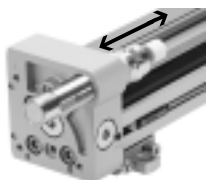

- Between 0 ... 25 mm per side
- For DGC-GF/DGC-KF/DGC-FA

4 Profile mounting M



- Profile mounting remains on the base plate after the drive is dismantled. This means faster assembly and removal without repeat adjustment
- For DGC-G/DGC-GF/DGC-KF/DGC-FA

5 Mechanical end-position limiter YWZ



- For variable stroke adjustment, e.g. for format adjustments
- The end stop can be mounted at any position along the stroke
- For DGC-GF/DGC-KF/DGC-FA

6 Intermediate position module Z1/Z2/Z3

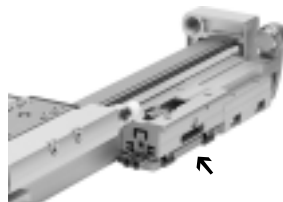

- Enables variable intermediate positions
- The intermediate position module can be mounted at any position along the stroke
- Precision repetition accuracy (0.02 mm) with high dynamic response
- For DGC-KF

Moment compensator FK



- Compensates for inaccuracies during mounting of the linear drive and external guide
- Max. offset 2.5 mm
- For DGC-G

Example

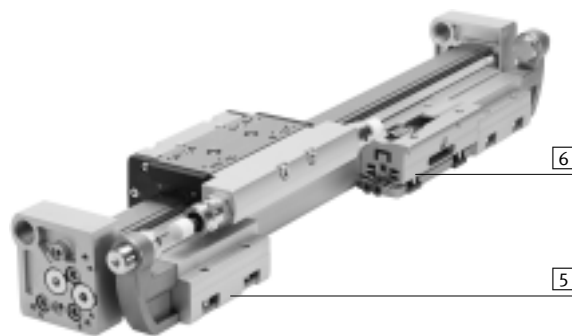
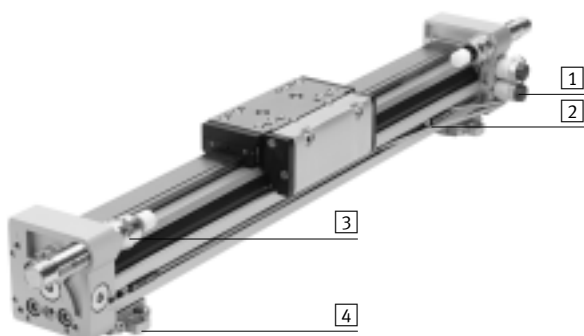

Linear drives DGC

Key features

Options

C – Central lubrication

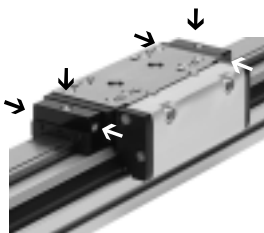

The lubrication adapter enables the guide of the linear drive DGC-KF to be permanently lubricated in applications in humid or wet ambient conditions using semi or fully automatic relubrication devices.

The adapters are suitable for oils and greases.

- For piston \varnothing 25, 32, 40, 63 mm
- For DGC-KF
- Connections:
 - On both sides of the slide
 - In three places (front, top, rear) on each side

Technical data → 51

1H-PN – Clamping unit



- 1-channel design, for holding loads
- Reliable holding is guaranteed since the forces act directly on the slide
- A limited number of emergency braking operations are permissible with the sizes 40 and 50

- For piston \varnothing 25, 32, 40, 50 mm
- For DGC-KF

Technical data → 48

DL – Supply port at the left end or at both ends

The linear drive is actuated at the right end or at both ends by default.

The linear drive can be actuated at the left end or at both ends by specifying the order code DL in the modular product system.

- For piston \varnothing 18, 25, 32, 40, 50, 63 mm
- For DGC-G, DGC-GF, DGC-KF

Linear drives DGC

Key features

Product variants

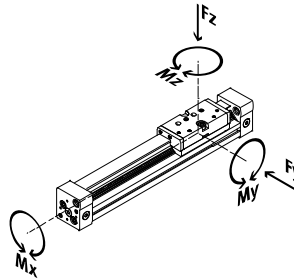

	Piston Ø [mm]	Theoretical force at 6 bar [N]	Guide characteristics					→ Page/ Internet
			Fy [N]	Fz [N]	Mx [Nm]	My [Nm]	Mz [Nm]	
Compact design DGC-K								
	18	153	–	120	0.8	11	1	dgc-k
	25	295	–	330	1.2	20	3	
	32	483	–	480	1.9	40	5	
	40	754	–	800	3.8	60	8	
	50	1,178	–	1,200	6	120	15	
	63	1,870	–	1,600	5.7	150	24	
	80	3,016	–	2,500	30.6	400	100	
Basic design DGC-G								
	8	30	150	150	0.5	2	2	6
	12	68	300	300	1.3	5	5	
	18	153	70	340	1.9	12	4	
	25	295	180	540	4	20	5	
	32	483	250	800	9	40	12	
	40	754	370	1,100	12	60	25	
	50	1,178	480	1,600	20	150	37	
	63	1,870	650	2,000	26	150	48	
Plain-bearing guide DGC-GF								
	18	153	440	540	3.4	20	8.5	22
	25	295	640	1,300	8.5	40	20	
	32	483	900	1,800	15	70	33	
	40	754	1,380	2,000	28	110	54	
	50	1,178	1,500	2,870	54	270	103	
	63	1,870	2,300	4,460	96	450	187	
Recirculating ball bearing guide DGC-KF								
	8	30	300	300	1.7	4.5	4.5	42
	12	68	650	650	3.5	10	10	
	18	153	1,850	1,850	16	51	51	
	25	295	3,050	3,050	36	97	97	
	32	483	3,310	3,310	54	150	150	
	40	754	6,890	6,890	144	380	380	
	50	1,178	6,890	6,890	144	634	634	
	63	1,870	15,200	15,200	529	1,157	1,157	
Heavy-duty guide DGC-HD								
	18	153	3,650	3,650	140	275	275	dgc-hd
	25	295	5,600	5,600	300	500	500	
	40	754	13,000	13,000	900	1,450	1,450	

Linear drives DGC-G

Peripherals overview

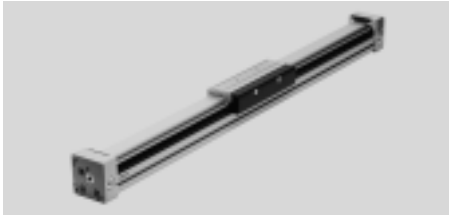

DGC-8/-12

-  - Note

1) End stops or shock absorbers must not be removed.

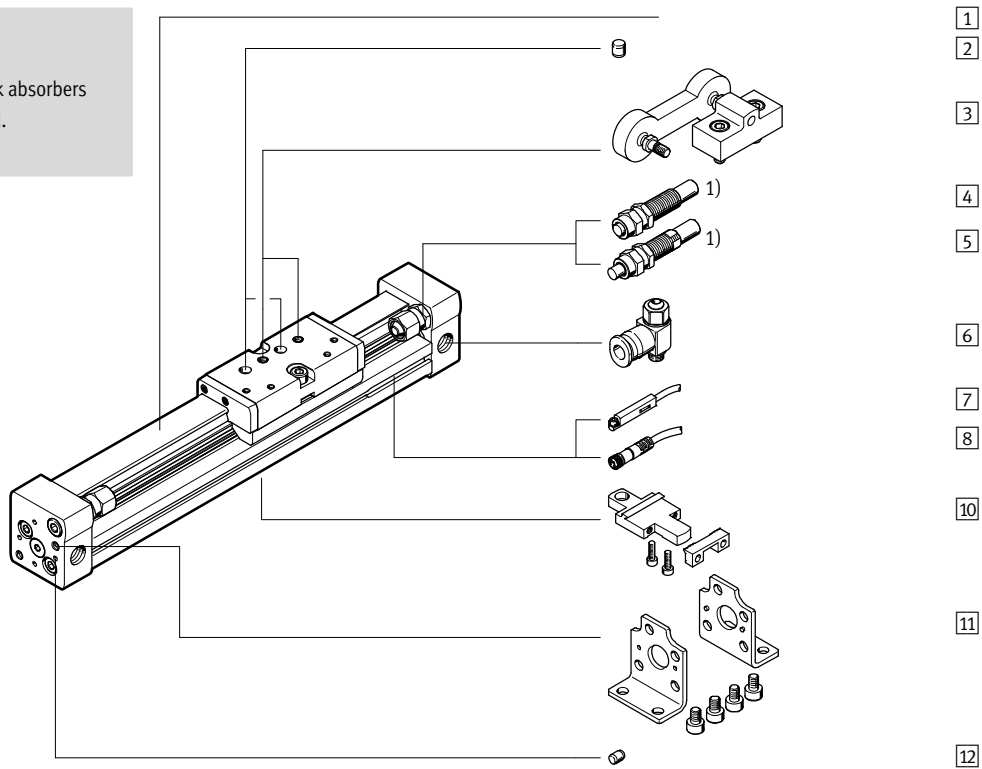

DGC-18 ... 63

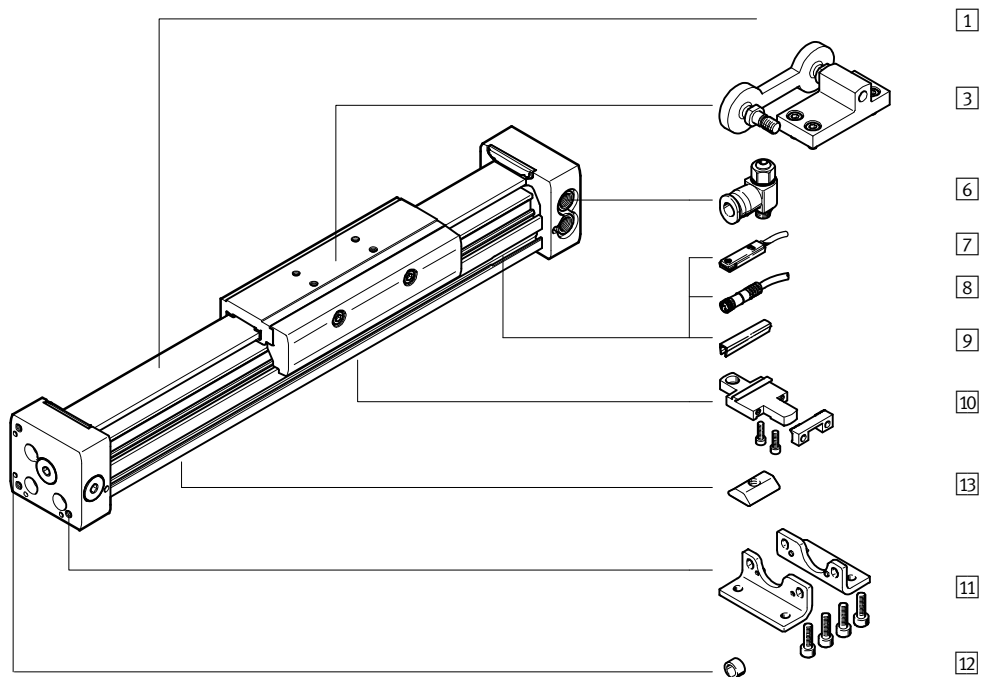

Linear drives DGC-G

Peripherals overview

Variants and accessories			
Type	For piston \varnothing	Brief description	→ Page/Internet
1) Linear drive DGC-G	8 ... 63	Linear drive without accessories, basic design	10
2) Centring pin ¹⁾ ZBS	8, 12	For centring loads and attachments on the slide	78
3) Driver FK	8 ... 63	Compensates inaccuracies in the mounting of the linear drive and external guide	72
– Cushioning P	8, 12	Non-adjustable, flexible cushioning. Used only at low speeds	21
– Cushioning PPV	18 ... 63	Adjustable pneumatic end position cushioning. Used at medium speeds	21
4) Shock absorber YSR	8, 12	Self-adjusting hydraulic shock absorber with spring return and linear cushioning characteristic	21
5) Shock absorber YSRW	8, 12	Self-adjusting hydraulic shock absorber with spring return and progressive cushioning characteristic	21
6) One-way flow control valve GRLA	8 ... 63	For regulating speed	78
7) Proximity sensor G/H/I/J	8 ... 63	For sensing the slide position	79
8) Cable with socket V	8 ... 63	For proximity sensor	79
9) Slot cover L	18 ... 63	For protecting against ingress of dirt and securing proximity sensor cables	78
10) Profile mounting M	8 ... 63	Simple and precise mounting option via dovetail connection	70
11) Foot mounting F	8 ... 63	For mounting on end cap	68
12) Centring pin/sleeve ZBS/ZBH	8, 12, 50, 63	For centring the drive without foot mountings (user-specific)	78
13) Slot nut B	25 ... 63	For mounting attachments	78

1) Included in the scope of delivery of the drive

Linear drives DGC-G

Type codes

		DGC	-	25	-	1000	-	G	-	PPV	-	A	-		-	
Type																
DGC	Linear drive															
Piston Ø [mm]																
Stroke [mm]																
Guide																
G	Basic design															
Cushioning																
P	Flexible cushioning, non-adjustable															
PPV	Adjustable end position cushioning															
YSR	Linear shock absorber, self-adjusting															
YSRW	Shock absorber, progressive, self-adjusting															
Position sensing																
A	For proximity sensor															
Compressed air supply																
-	At right side only or at both ends															
DL	At left side only or at both ends															
Lubrication																
-	Standard															
H1	For food industry															

Linear drives DGC-G

Type codes

→		+ ZUB	-	F			2B	2G		2L	
Accessories											
ZUB	Accessories supplied loose										
Foot mounting											
F	Foot mounting										
Profile mounting											
...M	Profile mounting										
Driver											
FK	Moment compensator										
Slot nut											
...B	For mounting slot										
Proximity sensor											
...G	With cable, 2.5 m										
...H	With plug										
...I	Contactless with cable, 2.5 m										
...J	Contactless, with plug										
Cable with socket											
...V	2.5 m										
Slot cover											
...L	For sensor slot										
User manual											
0	Express waiver – no operating instructions to be included										

Linear drives DGC-G

Technical data

Function

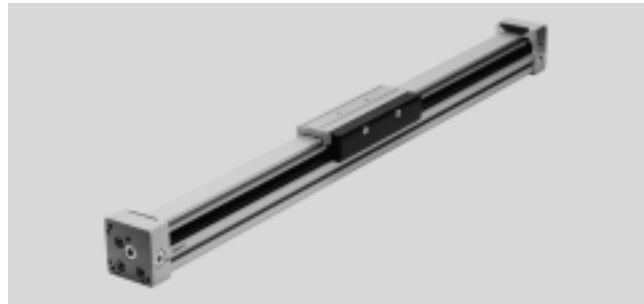
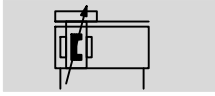

- - Diameter
8 ... 63 mm
- - Stroke length
1 ... 8,500 mm

General technical data								
Piston \varnothing	8	12	18	25	32	40	50	63
Stroke [mm]	1 ... 1,500		1 ... 2,000		1 ... 3,000		1 ... 8,500	
Pneumatic connection	M5			G $\frac{1}{8}$		G $\frac{1}{4}$		G $\frac{3}{8}$
Mode of operation	Double-acting							
Design	Rodless drive							
Moment compensator principle	Slotted cylinder, mechanically coupled							
Guide	Basic design							
Mounting position	Any							
Cushioning \rightarrow 13								
DGC-...-P	Non-adjustable at both ends		-					
DGC-...-PPV	-		Adjustable at both ends					
DGC-...-YSR...	Self-adjusting at both ends		-					
Cushioning length with PPV cushioning [mm]	-		16.5	15.5	17.5	29.5	29.8	31.1
Position sensing	Via proximity sensor							
Type of mounting	Profile mounting							
	Foot mounting							
	Direct mounting							
Max. speed [m/s]	1	1.2	3					

Note: This product conforms to ISO 1179-1 and to ISO 228-1

Operating and environmental conditions									
Piston \varnothing	8	12	18	25	32	40	50	63	
Operating pressure [bar]	2.5 ... 8		2 ... 8			1.5 ... 8			
Operating medium	Compressed air in accordance with ISO 8573-1:2010 [7:-:-]								
Note on operating/pilot medium	Operation with lubricated medium possible (in which case lubricated operation will always be required)								
Ambient temperature ¹⁾ [°C]	+5 ... +60		-10 ... +60						
Suitability for use in the food industry ²⁾	As per manufacturer's declaration								
Corrosion resistance class CRC ³⁾	2								
ATEX	Specified types \rightarrow www.festo.com								

1) Note operating range of proximity sensors

2) Additional information www.festo.com/sp \rightarrow User documentation.

3) CRC2: Corrosion resistance class to Festo standard 940 070

Components with medium corrosion exposure. Externally visible components with significant decorative function in direct contact with normal industrial atmosphere or media such as coolants and lubricants.

Forces [N] and impact energy [J]								
Piston \varnothing	8	12	18	25	32	40	50	63
Theoretical force at 6 bar	30	68	153	295	483	754	1,178	1,870
Impact energy in the end positions	\rightarrow 13							

Linear drives DGC-G

Technical data

Weight [g]								
Piston Ø	8	12	18	25	32	40	50	63
Basic weight with 0 mm stroke	170	290	546	1,004	2,126	4,121	9,050	14,040
Additional weight per 10 mm stroke	9	12	22	34	54	77	116	150
Moving load	36	65	178	287	508	1,312	2,850	4,330

Adjustable end-position range d [mm]

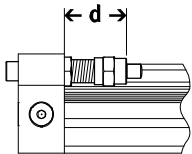

- - Note

The permissible kinetic energy decreases if the stroke is reduced

with PPV adjustable cushioning at both ends.

Piston Ø	8	12	18	25	32	40	50	63
Cushioning								
DGC-...-P/PPV	11.3 ... 16.3	12.7 ... 17.7	-					
DGC-...-YSR/YSRW	12.8 ... 22.8	14 ... 24	-					

Materials

Sectional view

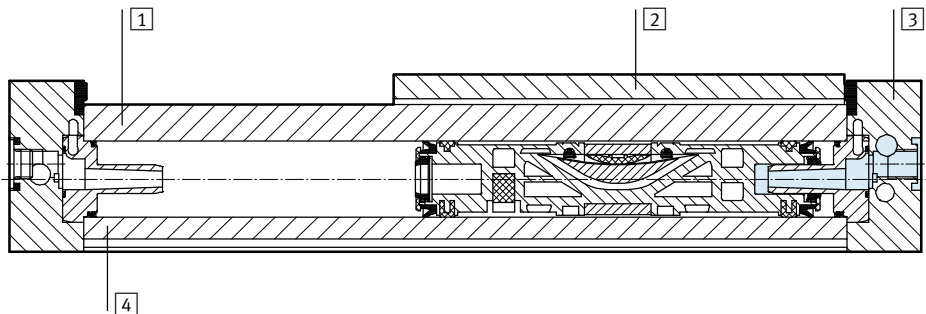

Linear drives		
1	Guide rail	Anodised aluminium
2	Slide	Anodised aluminium
3	End cap	Anodised aluminium
4	Cylinder barrel	Anodised aluminium
-	Piston seal	Polyurethane
-	Sealing band/cover band	Polyurethane
-	Slide elements	Polyacetal
-	Note on materials	RoHS compliant

Influence of ferritic materials on proximity sensors

Ferritic materials (steel parts or panels) directly next to the proximity sensors can cause sensing malfunctions.

The following safety distances must be observed.

The distance depends on the position of the proximity sensor (see 1 and 2).

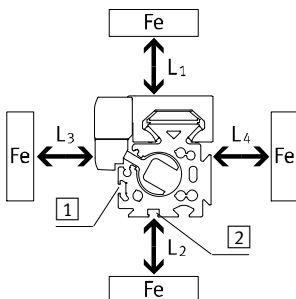

Piston Ø		8	12	18	25	32	40	50	63
Distance L1	1 [mm]	0	0	0	0	0	0	0	0
	2 [mm]	-	-	0	0	0	0	0	0
Distance L2	1 [mm]	20	10	10	10	0	0	0	0
	2 [mm]	-	-	25	25	25	25	25	25
Distance L3	1 [mm]	30	25	25	25	25	25	25	25
	2 [mm]	-	-	10	10	0	0	0	0
Distance L4	1 [mm]	0	0	0	0	0	0	0	0
	2 [mm]	-	-	0	0	0	0	0	0

Linear drives DGC-G

Technical data

Characteristic load values

The indicated forces and torques refer to the centre of the slide surface.

These values must not be exceeded during dynamic operation. Special attention must be paid to the cushioning phase.

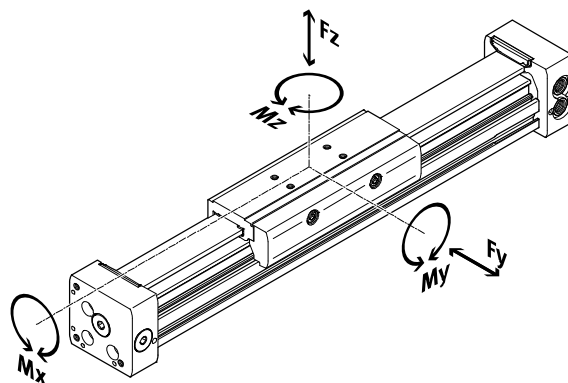

 Note

In order to avoid frictional restraint of the guide in the case of the basic drive DGC-G when used in vertical mode and with a high torque load, the variant with the recirculating ball bearing guide DGC-KF → 42 is recommended.

If the drive is simultaneously subjected to several of the indicated forces and torques, the following equation must be satisfied in addition to the indicated maximum loads:

$$\frac{F_y}{F_{y_{max}}} + \frac{F_z}{F_{z_{max}}} + \frac{M_x}{M_{x_{max}}} + \frac{M_y}{M_{y_{max}}} + \frac{M_z}{M_{z_{max}}} \leq 1$$

Permissible forces and torques		8	12	18	25	32	40	50	63
Piston Ø		8	12	18	25	32	40	50	63
F _y _{max.}	[N]	150	300	70	180	250	370	480	650
F _z _{max.}	[N]	150	300	340	540	800	1,100	1,600	2,000
M _x _{max.}	[Nm]	0.5	1.3	1.9	4	9	12	20	26
M _y _{max.}	[Nm]	2	5	12	20	40	60	150	150
M _z _{max.}	[Nm]	2	5	4	5	12	25	37	48

Linear drives DGC-G

Technical data

Maximum permissible piston speed v as a function of effective load m and distance r_{max} from centre of gravity of load

Piston \varnothing 8/12 with P cushioning

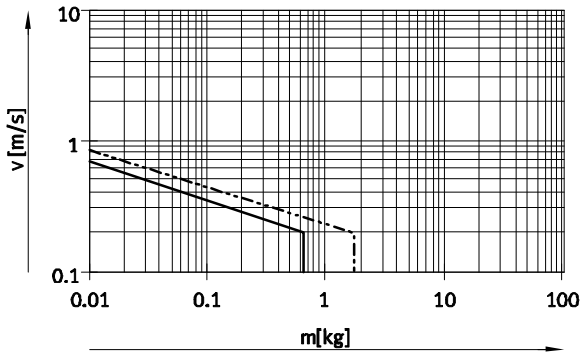

Piston \varnothing 18 ... 63 with PPV cushioning

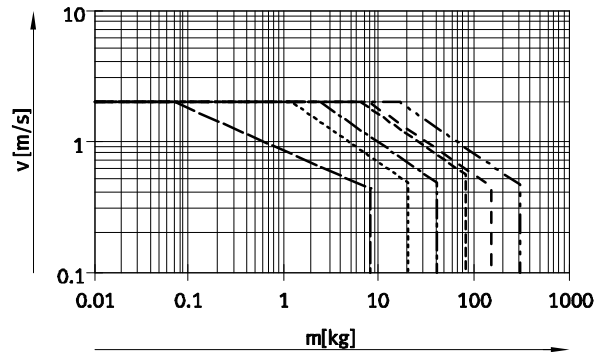

Piston \varnothing 8/12 with YSR cushioning

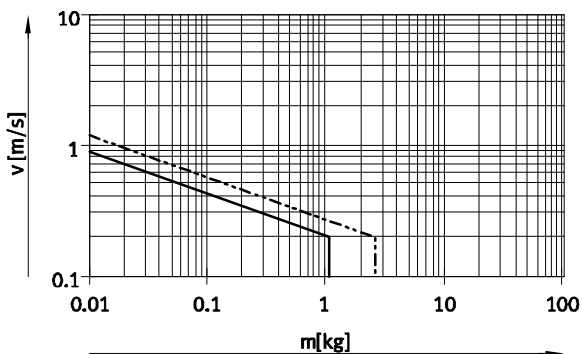

Piston \varnothing 8/12 with YSRW cushioning

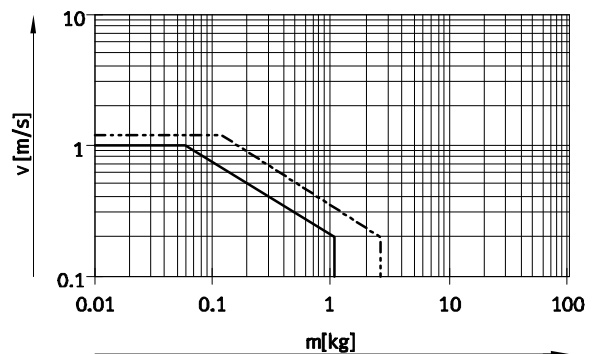

- \varnothing 8 - - - - \varnothing 18 - - - - \varnothing 40
- - - - \varnothing 12 - \varnothing 25 - - - - \varnothing 50
- \varnothing 32 - - - - \varnothing 63

Note
This data represents the maximum values that can be achieved. In practice, values fluctuate relative to the position of the effective load and mounting position.

Operating range of cushioning

The end-position cushioning must be adjusted to ensure jerk-free operation. If the operating conditions are outside the permissible range, the load to be moved must be cushioned using suitable equipment (external shock absorbers), preferably at the centre of gravity of the load.

Note
To avoid distortion in the slide, the attachments must maintain a flatness of at least 0.03 mm.

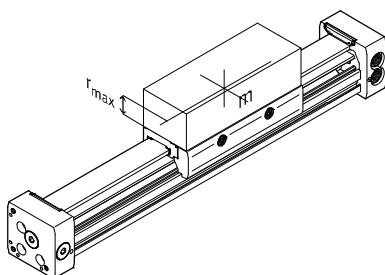

Specifications for horizontal mounting position:

Piston \varnothing	8	12	18	25	32	40	50	63
Distance r_{max} [mm]	25	35	35	50	50	50	50	50

Linear drives DGC-G

Technical data

Number of profile mountings MUC as a function of force due to weight F and support spacing l

In order to limit deflection in the case of large strokes, the drive may need to be supported. The following graphs

help to determine the maximum permissible support spacing as a function

of mounting position, force due to weight and normal force.

Horizontal mounting position

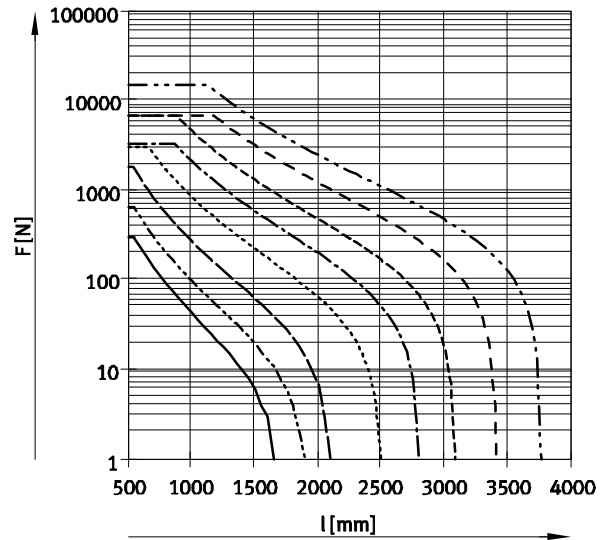
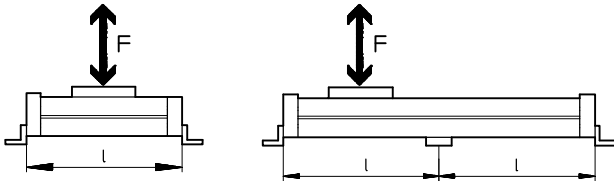

Vertical mounting position

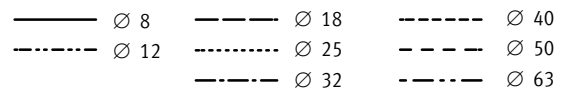
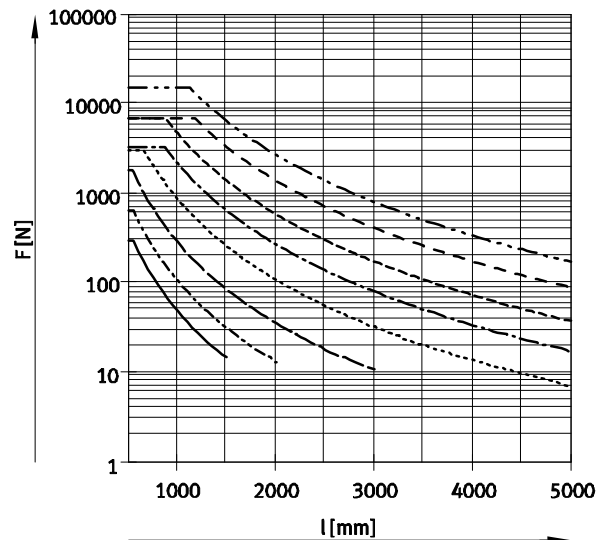
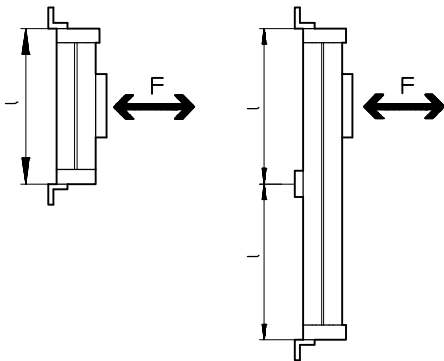

Example:

The drive DGC-25-1500 is subjected to a force of 300 N in a horizontal mounting position.

The drive has an overall length of:

$$\begin{aligned}
 l &= \text{stroke length} + L1 \\
 &= 1,500 \text{ mm} + 200 \text{ mm} \\
 &= 1,700 \text{ mm}
 \end{aligned}$$

According to the graph, the max. support spacing for the drive DGC-25 with a force of 300 N is 1,300 mm.

In this example, profile mountings are required as the max. support spacing (1,300 mm) is smaller than the overall length of the drive (1,700 mm).

Linear drives DGC-G

Technical data

Dimensions

Download CAD data → www.festo.com

∅ 8 and 12

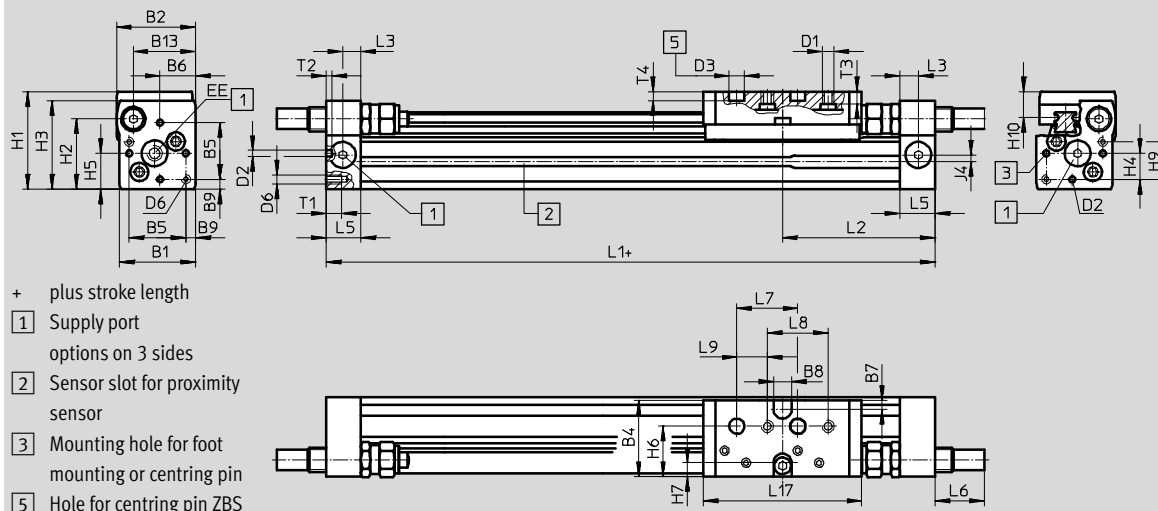

+ plus stroke length

- 1 Supply port options on 3 sides
- 2 Sensor slot for proximity sensor
- 3 Mounting hole for foot mounting or centring pin
- 5 Hole for centring pin ZBS

∅	B1	B2	B4	B5	B6	B7	B8	B9	B13	D1	D2	D3	D6
[mm]							±0.05	±0.1			∅ H8	∅ H7	
8	25	26	25.5	18.6	11.7	3	6	3.2	20.5	M4	2	5	M3
12	30.2	31	30.5	20.6	13.5	3	8	4.8	25	M4	2	5	M4

∅	EE	H1	H2	H3	H4	H5	H6	H7	H9	H10	J4	L1	L2
[mm]													
8	M5	32	23	29	8.5	11.7	16.5	4.5	12.3	8.7	2.2	100	50.1
12	M5	37.5	28.5	34.5	8.7	13.5	20.5	5	14.7	9.8	3	125	62.1

∅	L3	L5	L6			L7	L8	L9	L17	T1	T2	T3	T4	Stroke tolerance
			P	YSR	YSRW									
[mm]						±0.03	±0.1	±0.1					+0.2	
8	6	11.5	0	16	16.2	20	20	10	52	5	2	4	3	0 ... 1.7
12	8	16	0	11.3	12.3	20	20	10	65	6	2	5	3	

Profile barrel

∅ 8

∅ 12



1 Sensor slot for proximity sensor

Linear drives DGC-G

Technical data

FESTO

Dimensions

Download CAD data → www.festo.com

∅ 18 ... 40

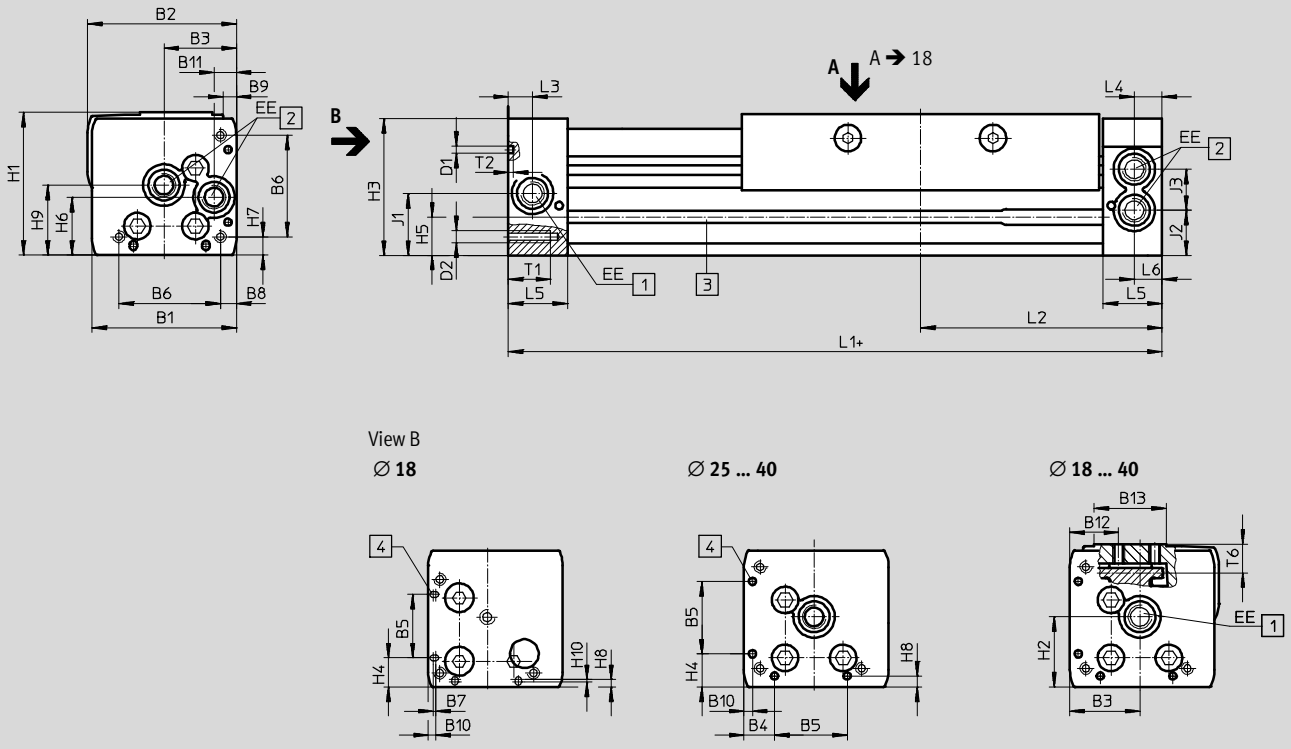

∅ 50/63

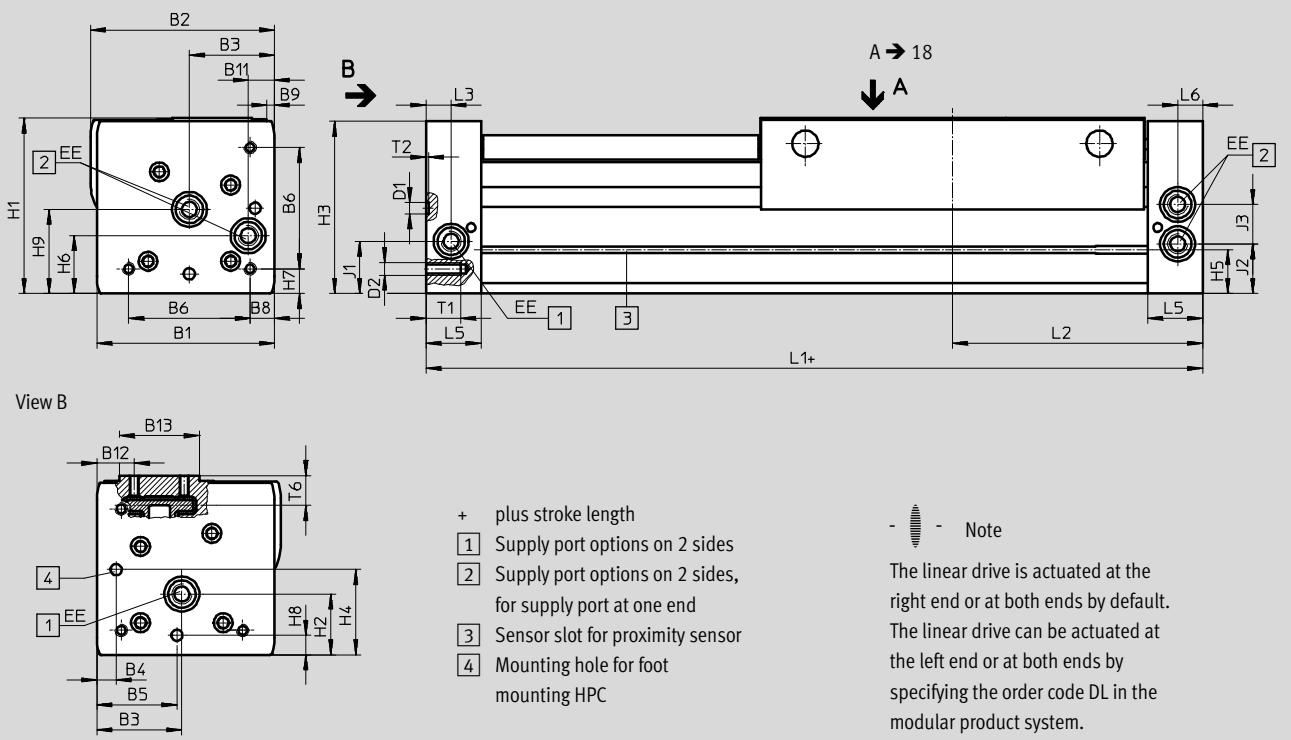

Linear drives DGC-G

Technical data

∅	B1	B2	B3	B4	B5	B6	B7	B8	B9	B10
[mm]					±0.05					
18	44.5	46.3	19.5	8.8	21	31	0.3	3.8	3.3	2.4
25	59.8	61.6	30	12.65	30	42		6.65	5.6	3.5
32	73	75.5	38.5	5.7	63.1	57.5		8.5	5	14
40	91	94.5	45	17.2	55	65		12.2	5.3	8
50	113	122	60	8	52.8	81.6	-	12	0	-
63	142	147	68	15.5	68	97	-	19.5	6	-

∅	B11	B12	B13	D1	D2	EE	H1	H2	H3	H4
[mm]				∅						±0.2
18	5.5	19.3	20	2±0.05	M4	M5	49.8	23.1	48.3	10.3
25	9.3	20.15	30	3±0.05	M5	G $\frac{1}{8}$	58.5	29	56.5	13
32	14.9	20.5	35	3±0.05	M6	G $\frac{1}{8}$	73	30	71.5	5.7
40	16.5	19.8	45	4±0.05	M6	G $\frac{1}{4}$	88	41.5	85	17.2
50	21	24	64	9 ^{H7}	M8	G $\frac{1}{4}$	120	38.5	116	52.8
63	21	30	64	9 ^{H7}	M10	G $\frac{3}{8}$	140	48.5	137.5	68

∅	H5	H6	H7	H8	H9	H10	J1	J2	J3	L1
[mm]										
18	13.4	20	5.3	2.4	25.2	0.4	20	16.5	11	150
25	15.8	24	7	4.5	29		26.1	18.6	17	200
32	17	27.7	8.5	14	35.2		30	22	18.5	250
40	25	36.5	12.2	8	44		35	26	26	300
50	29.3	36	12	8	53	-	30.5	30.5	28	350
63	34.8	46	19.5	15.5	67	-	41.5	39.5	31.5	400

∅	L2	L3	L4	L5	L6	T1	T2	T6	Stroke tolerance
[mm]									
18	74.5	5.7	5.8	15	5.5	9	2	10.7	0 ... 2.5
25	100	10.5	10.6	24.5	10.6	17.5	2	12	
32	124.8	14.5	14.5	30.5	14.5	15	2	13.8	
40	150	14.6	14.6	33.5	14.6	20	3	16.8	
50	175	17	-	41	17	24	2.1 ^{+0.2}	20.75	
63	200	20	-	44	20	27.5	2.1 ^{+0.2}	20.75	

· | - Note: This product conforms to ISO 1179-1 and to ISO 228-1

Linear drives DGC-G

Technical data

FESTO

Dimensions

Download CAD data → www.festo.com

Slide – View A

Ø 18

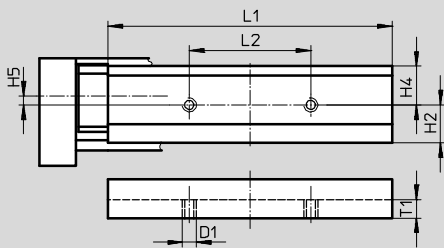

Ø 25

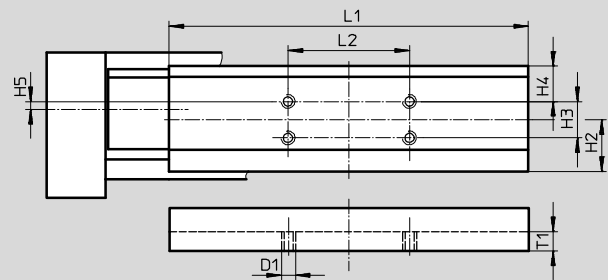

Ø 32

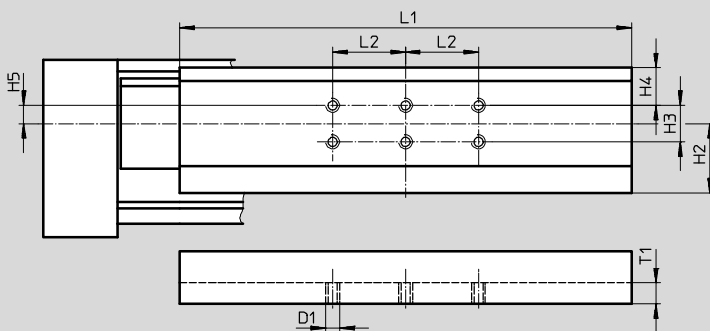

Ø 40

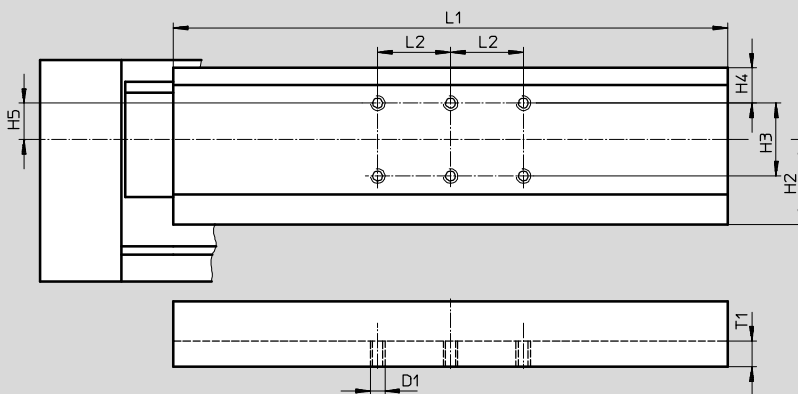

Ø 50

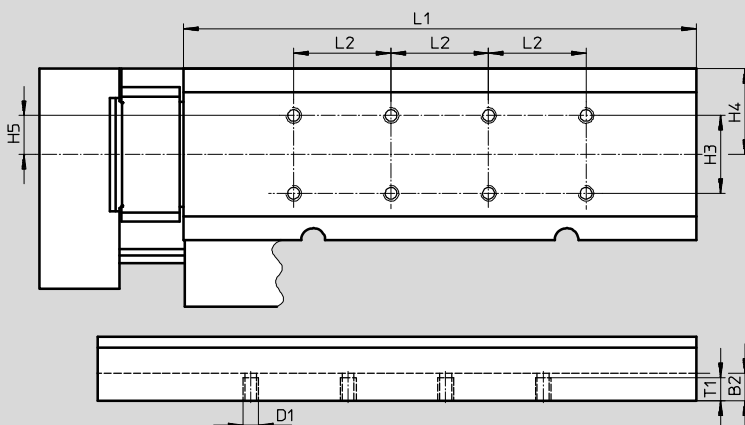

Linear drives DGC-G

Technical data

Dimensions

Download CAD-Daten → www.festo.com

Slide – View A

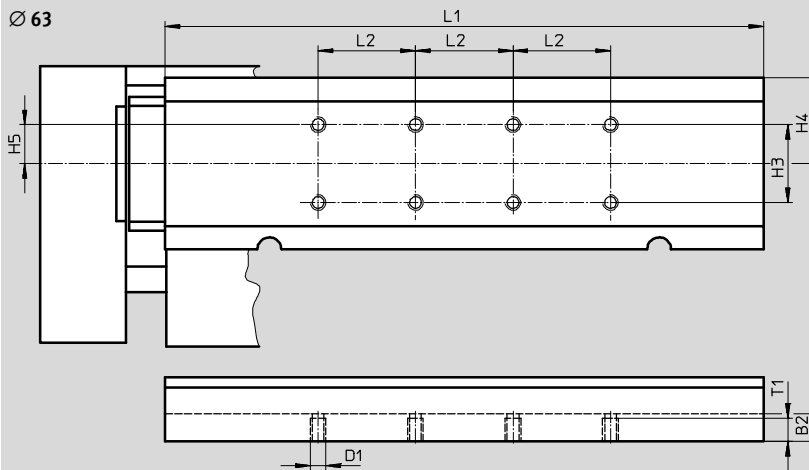

Ø [mm]	B2	D1	H2 ±0.1	H3 ±0.1	H4	H5	L1	L2 ±0.1	T1
18	-	M5	15.6	-	16	2	117±0.05	50	7
25	-	M5	21.35	15	14.55	4.85	148±0.05	50	8
32	-	M5	28.5	15	15.5	7.5	186±0.05	30	8.6
40	-	M6	35	30	14.5	15	228±0.05	30	10.5
50	14	M8	-	40	44	20	263±0.1	50	13
63	14	M8	-	40	44	20	307±0.1	50	13

Profile barrel

Ø 18

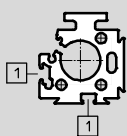

Ø 25

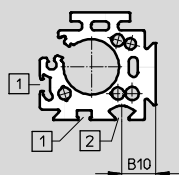

Ø 32

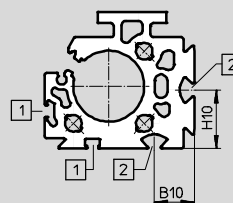

Ø 40

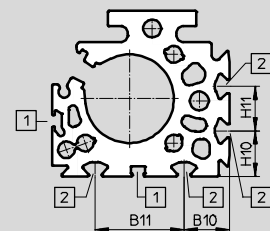

Ø 50

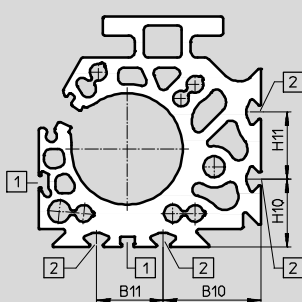

Ø 63

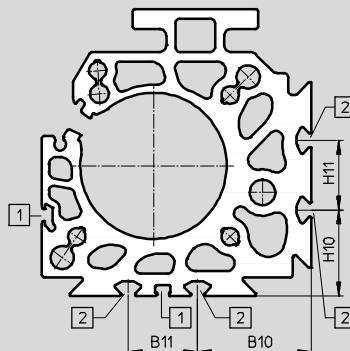

- 1 Sensor slot for proximity sensor
- 2 Mounting slot for slot nut

Ø [mm]	B10	B11	H10	H11
25	15.23	-	-	-
32	18	-	26.5	-
40	20.5	40	20.5	20
50	43.8	30	30.5	30
63	49	30	37	30

Linear drives DGC-G

Ordering data – Modular products

Order code

Mandatory data/options

DGC-8/-12

-  - Note

1) End stops or shock absorbers must not be removed.

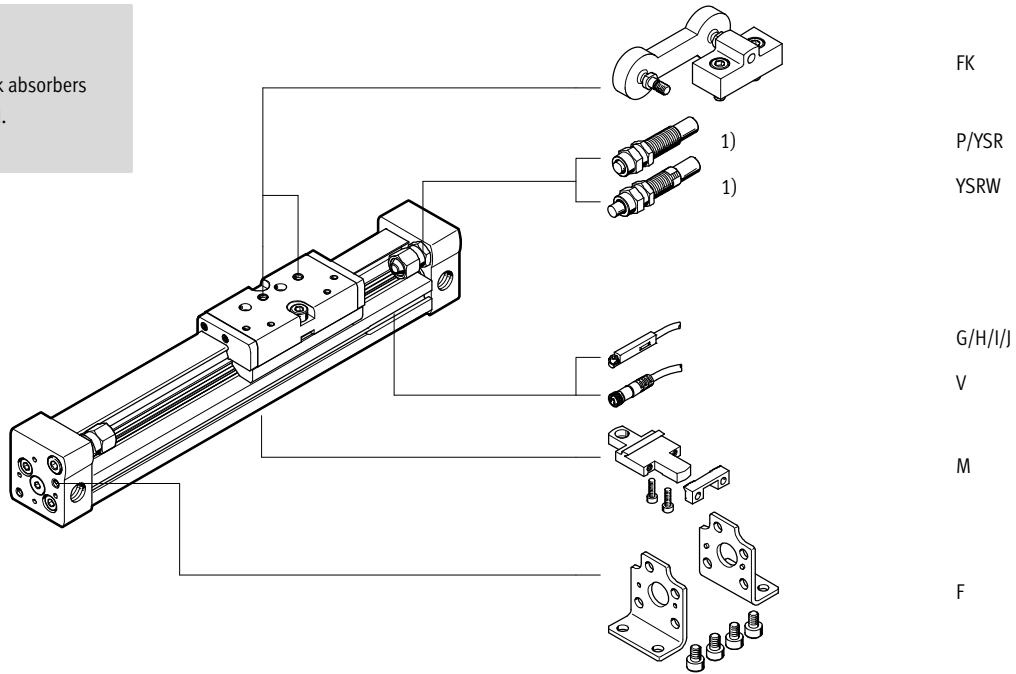

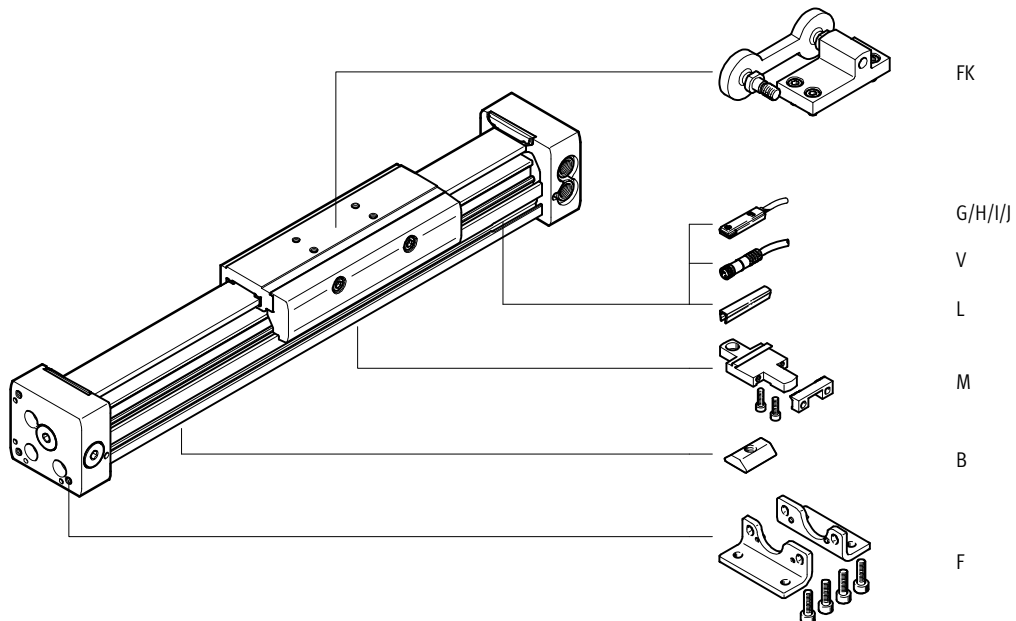

DGC-18 ... 63

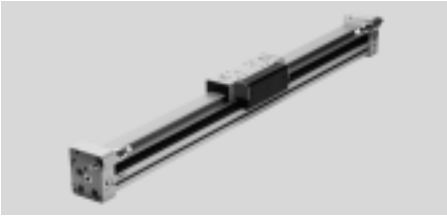

Linear drives DGC-GF, with plain-bearing guide

Peripherals overview



-  - Note
 1) End stops or shock absorbers must not be removed.

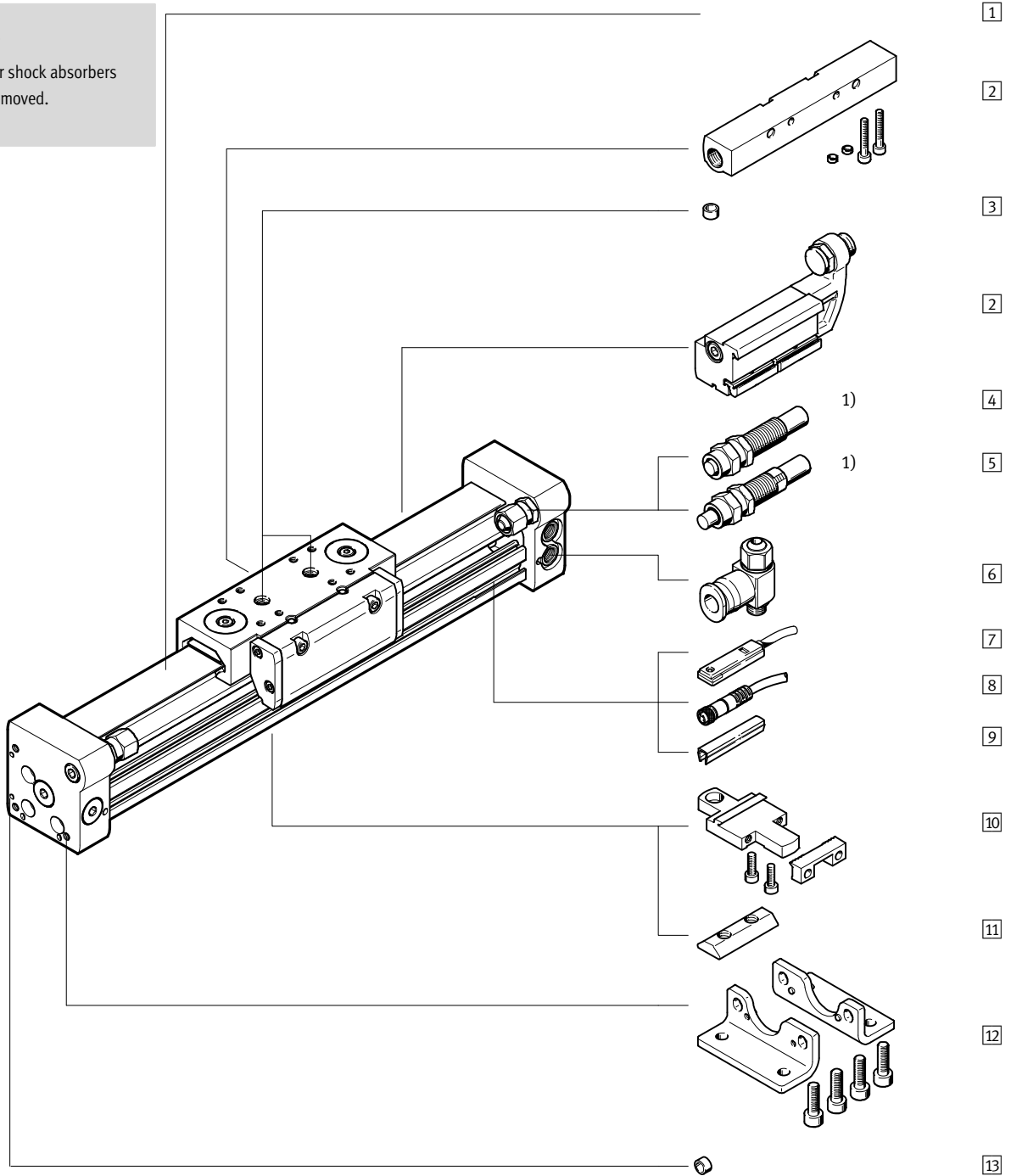

Linear drives DGC-GF, with plain-bearing guide

Peripherals overview

Variants and accessories			
Type	For piston \varnothing	Brief description	→ Page/Internet
1 Linear drive DGC-GF	18 ... 63	Linear drive without accessories, plain-bearing guide	26
2 Mechanical end position limiter YWZ	18 ... 63	For variable end position adjustment, e.g. for format adjustments	74
3 Centring pin/sleeve ¹⁾ ZBS/ZBH	18 ... 63	For centring loads and attachments on the slide	78
- Cushioning PPV	18 ... 63	Adjustable pneumatic end position cushioning. Used at medium speeds	41
4 Shock absorber YSR	18 ... 63	Self-adjusting hydraulic shock absorber with spring return and linear cushioning characteristic	41
5 Shock absorber YSRW	18 ... 63	Self-adjusting hydraulic shock absorber with spring return and progressive cushioning characteristic	41
6 One-way flow control valve GRLA	18 ... 63	For regulating speed	78
7 Proximity sensor G/H/I/J	18 ... 63	For sensing the slide position	79
8 Cable with socket V	18 ... 63	For proximity sensor	79
9 Slot cover L	18 ... 63	For protecting against ingress of dirt and securing proximity sensor cables	78
10 Profile mounting M	18 ... 63	Simple and precise mounting option via dovetail connection	70
11 Slot nut B	25 ... 63	For mounting attachments	78
12 Foot mounting F	18 ... 63	For mounting on end cap	68
13 Centring sleeve ZBH	50, 63	For centring the drive without foot mountings (user-specific)	78

1) Included in the scope of delivery of the drive

Linear drives DGC-GF, with plain-bearing guide

Type codes

		DGC	-	25	-	1000	-	GF	-	YSR	-	A	-		-	
Type																
DGC	Linear drive															
Piston Ø [mm]																
Stroke [mm]																
Guide																
GF	Plain-bearing guide															
Cushioning																
PPV	Adjustable end position cushioning															
YSR	Linear shock absorber, self-adjusting															
YSRW	Shock absorber, progressive, self-adjusting															
Position sensing																
A	For proximity sensor															
Compressed air supply																
-	At right side only or at both ends															
DL	At left side only or at both ends															
Lubrication																
-	Standard															
H1	For food industry															

Linear drives DGC-GF, with plain-bearing guide

Type codes

➔	+ ZUB	-	F	2B	2G	2L
Accessories						
ZUB	Accessories supplied loose					
Foot mounting						
F	Foot mounting					
Profile mounting						
...M	Profile mounting					
Slot nut						
...B	For mounting slot					
Proximity sensor						
...G	With cable, 2.5 m					
...H	With plug					
...I	Contactless with cable, 2.5 m					
...J	Contactless, with plug					
Cable with socket						
...V	2.5 m					
Slot cover						
...L	For sensor slot					
Mechanical end position limiter						
YWZ1	Variable end position, at one end					
YWZ2	Variable end position, at both ends					
User manual						
0	Express waiver – no operating instructions to be included					

Linear drives DGC-GF, with plain-bearing guide

Technical data

Function

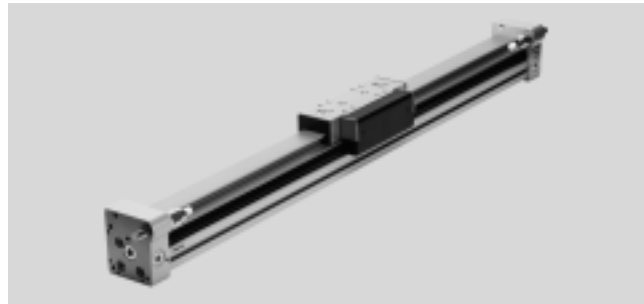
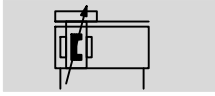

- - Diameter
18 ... 63 mm
- - Stroke length
1 ... 8,500 mm

General technical data						
Piston \varnothing	18	25	32	40	50	63
Stroke [mm]	1 ... 3,000		1 ... 8,500		1 ... 5,000	
Pneumatic connection	M5	G $\frac{1}{8}$		G $\frac{1}{4}$		G $\frac{3}{8}$
Mode of operation	Double-acting					
Design	Rodless drive					
Moment compensator principle	Slotted cylinder, mechanically coupled					
Guide	Plain-bearing guide					
Mounting position	Any					
Cushioning \rightarrow 29						
DGC-...-PPV	Adjustable at both ends					
DGC-...-YSR...	Self-adjusting at both ends					
Cushioning length with PPV cushioning [mm]	16.5	15.5	17.5	29.5	29.8	31.1
Position sensing	Via proximity sensor					
Type of mounting	Profile mounting					
	Foot mounting					
	Direct mounting					
Max. speed [m/s]	3					

Note: This product conforms to ISO 1179-1 and to ISO 228-1

Operating and environmental conditions						
Piston \varnothing	18	25	32	40	50	63
Operating pressure [bar]	2 ... 8			1.5 ... 8		
Operating medium	Compressed air in accordance with ISO 8573-1:2010 [7:-:-]					
Note on operating/pilot medium	Operation with lubricated medium possible (in which case lubricated operation will always be required)					
Ambient temperature ¹⁾ [°C]	-10 ... +60					
Suitability for use in the food industry ²⁾	As per manufacturer's declaration					
Corrosion resistance class CRC ³⁾	2					
ATEX	Specified types \rightarrow www.festo.com					

1) Note operating range of proximity sensors

2) Additional information www.festo.com/sp \rightarrow User documentation.

3) CRC2: Corrosion resistance class to Festo standard 940 070

Components with medium corrosion exposure. Externally visible components with significant decorative function in direct contact with normal industrial atmosphere or media such as coolants and lubricants.

Forces [N] and impact energy [J]						
Piston \varnothing	18	25	32	40	50	63
Theoretical force at 6 bar	153	295	483	754	1,178	1,870
Impact energy in the end positions	\rightarrow 29					

Linear drives DGC-GF, with plain-bearing guide

Technical data

Weight [g]						
Piston Ø	18	25	32	40	50	63
Basic weight with 0 mm stroke	763	1,609	2,532	5,252	10,065	16,308
Additional weight per 10 mm stroke	23	35	55	76	117	180
Moving load	267	526	824	1,725	3,319	5,226

Adjustable end-position range d [mm]

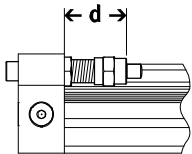

The permissible kinetic energy decreases if the stroke is reduced

with PPV adjustable cushioning at both ends.

Piston Ø	18	25	32	40	50	63
Cushioning						
DGC-...-PPV	13.8 ... 15.8	21.1 ... 25.1	25.2 ... 30.2	28.7 ... 33.7	28.7 ... 33.7	38.8 ... 43.8
DGC-...-YSR/YSRW	14.5 ... 24.5	22.5 ... 32.5	27.3 ... 37.3	31 ... 41	31 ... 56	41 ... 76

Materials

Sectional view

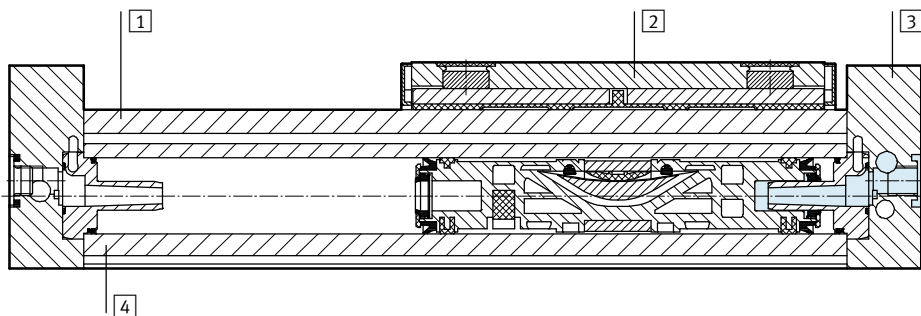

Linear drives		
1	Guide rail	Anodised aluminium
2	Slide	Anodised aluminium
3	End cap	Anodised aluminium
4	Cylinder barrel	Anodised aluminium
-	Piston seal	Polyurethane
-	Sealing band/cover band	Polyurethane
-	Slide elements	Polyacetal
-	Note on materials	RoHS compliant

Influence of ferritic materials on proximity sensors

Ferritic materials (steel parts or panels) directly next to the proximity sensors can cause sensing malfunctions.

The following safety distances must be observed.

The distance depends on the position of the proximity sensor (see 1 and 2).

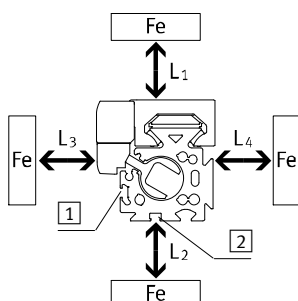

Piston Ø		8	12	18	25	32	40	50	63
Distance L1	1 [mm]	0	0	0	0	0	0	0	0
	2 [mm]	-	-	0	0	0	0	0	0
Distance L2	1 [mm]	20	10	10	10	0	0	0	0
	2 [mm]	-	-	25	25	25	25	25	25
Distance L3	1 [mm]	30	25	25	25	25	25	25	25
	2 [mm]	-	-	10	10	0	0	0	0
Distance L4	1 [mm]	0	0	0	0	0	0	0	0
	2 [mm]	-	-	0	0	0	0	0	0

Linear drives DGC-GF, with plain-bearing guide

Technical data

Characteristic load values

The indicated forces and torques refer to the centre of the slide surface.

These values must not be exceeded during dynamic operation. Special attention must be paid to the cushioning phase.

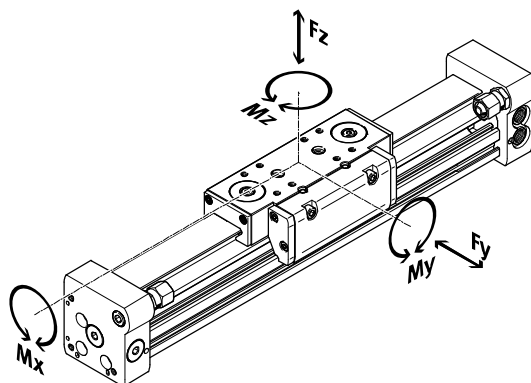

 Note

In order to avoid frictional restraint of the guide in the case of the drive DGC-GF with plain-bearing guide when used in vertical mode and with a high torque load, the variant with the recirculating ball bearing guide DGC-KF → 42 is recommended.

If the drive is simultaneously subjected to several of the indicated forces and torques, the following equation must be satisfied in addition to the indicated maximum loads:

$$\frac{F_y}{F_{y_{max}}} + \frac{F_z}{F_{z_{max}}} + \frac{M_x}{M_{x_{max}}} + \frac{M_y}{M_{y_{max}}} + \frac{M_z}{M_{z_{max}}} \leq 1$$

Permissible forces and torques in relation to a travel speed of 0.2 m/s							
Piston Ø		18	25	32	40	50	63
F _y _{max.}	[N]	440	640	900	1,380	1,500	2,300
F _z _{max.}	[N]	540	1,300	1,800	2,000	2,870	4,460
M _x _{max.}	[Nm]	3.4	8.5	15	28	54	96
M _y _{max.}	[Nm]	20	40	70	110	270	450
M _z _{max.}	[Nm]	8.5	20	33	54	103	187

Linear drives DGC-GF, with plain-bearing guide

Technical data

Number of profile mountings MUC as a function of force due to weight F and support spacing l

In order to limit deflection in the case of large strokes, the drive may need to be supported. The following graphs

help to determine the maximum permissible support spacing as a

function of mounting position, force due to weight and normal force.

Horizontal mounting position

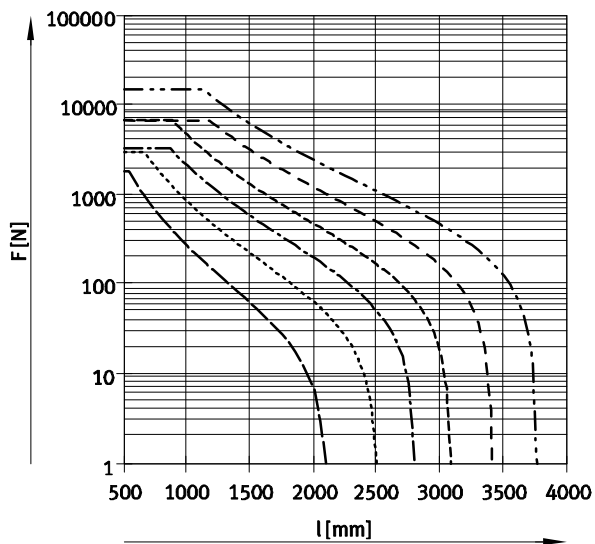
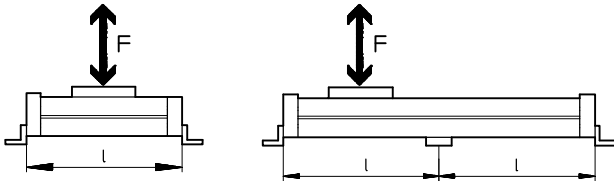

Linear drives DGC-GF, with plain-bearing guide

Technical data

Number of profile mountings MUC as a function of force due to weight F and support spacing l

In order to limit deflection in the case of large strokes, the drive may need to be supported. The following graphs help to determine the maximum permissible support spacing as a function of mounting position, force due to weight and normal force.

Vertical mounting position

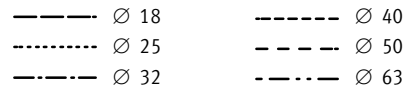
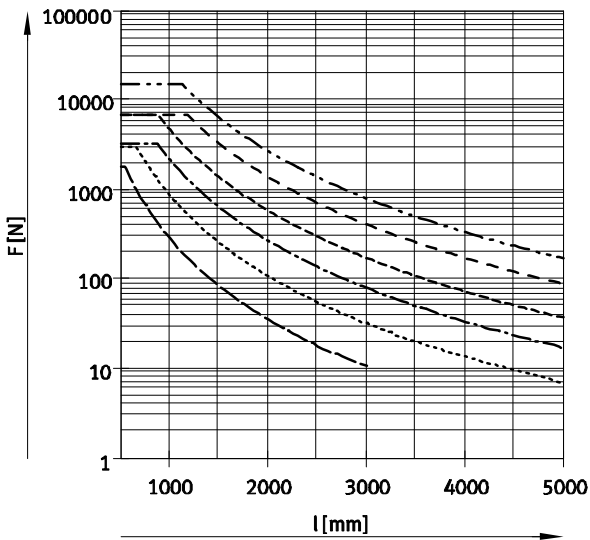
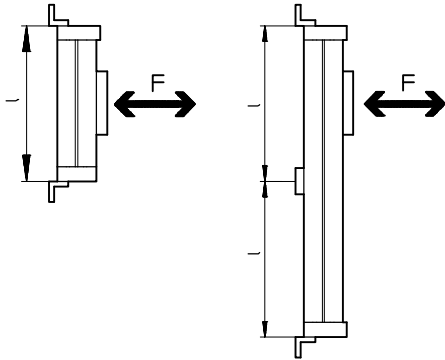

Example:

The drive DGC-25-1500 is subjected to a force of 300 N in a horizontal mounting position.

The drive has an overall length of:
 $l = \text{stroke length} + L1$
 (see dimensions)
 $= 1,500 \text{ mm} + 200 \text{ mm}$
 $= 1,700 \text{ mm}$

According to the graph, the max. support spacing for the drive DGC-25 with a force of 300 N is 1,300 mm.

In this example, profile mountings are required as the max. support spacing (1,300 mm) is smaller than the overall length of the drive (1,700 mm).

Linear drives DGC-GF, with plain-bearing guide

Technical data

FESTO

Dimensions

Download CAD data → www.festo.com

∅ 18 ... 40

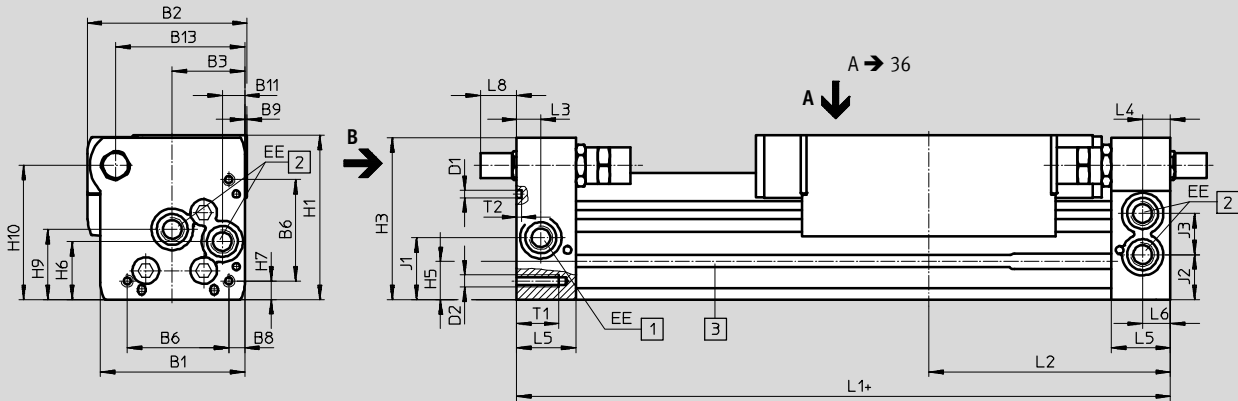

View B
∅ 18

∅ 25 ... 40

∅ 18 ... 40

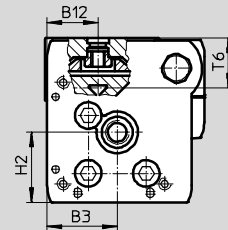
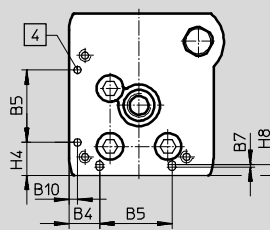
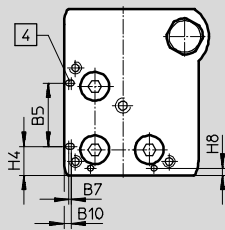

+ plus stroke length

- 1 Supply port options on 2 sides
- 2 Supply port options on 2 sides, for supply port at one end
- 3 Sensor slot for proximity sensor
- 4 Mounting hole for foot mounting HPC

- Note

The linear drive is actuated at the right end or at both ends by default. The linear drive can be actuated at the left end or at both ends by specifying the order code DL in the modular product system.

Linear drives DGC-GF, with plain-bearing guide

Technical data

∅ [mm]	B1	B2	B3	B4	B5 ±0.05	B6	B7	B8	B9	B10	B11
18	44.5	49.9	19.5	8.8	21	31	0.8	3.8	1	2.4	5.5
25	59.8	66	30	12.65	30	42	1	6.65	1	3.5	9.3
32	73	79	38.5	5.7	63.1	57.5	–	8.5	1.5	14	14.9
40	91	98.5	45	17.2	55	65	–	12.2	2	8	16.5

∅ [mm]	B12	B13	D1 ∅ ±0.05	D2	EE	H1	H2	H3	H4 ±0.2	H5	H6
18	15.5	39	2	M4	M5	56.3	23.1	55	9.6	13.4	20
25	21	53.5	3	M5	G $\frac{1}{8}$	68	29	67	13.65	15.8	24
32	18	66.5	3	M6	G $\frac{1}{8}$	78.5	30	77	5.7	17	27.7
40	24.8	80.5	4	M6	G $\frac{1}{4}$	99.5	41.5	97.5	17.2	25	36.5

∅ [mm]	H7	H8	H9	H10	J1	J2	J3	L1	L2	L3	L4
18	4.6	2.4	25.2	46	20	16.5	11	150	74.5	5.7	5.8
25	7.65	4.5	29	55.5	26.1	18.6	17	200	100	10.5	10.6
32	8.5	14	35.2	63.8	30	22	18.5	250	124.8	14.5	14.5
40	12.2	8	44	81.5	35	26	26	300	150	14.6	14.6

∅ [mm]	L5	L6	L8			T1	T2	T6	Stroke tolerance
			PPV	YSR	YSRW				
18	15	5.5	0	15.9	19.4	9	2	17.1	0 ... 2.5
25	24.5	10.6	0	12.5	15	17.5	2	20.5	
32	30.5	14.5	0	8.5	15.5	15	2	21.3	
40	33.5	14.6	0	12.8	21	20	3	30.7	

– † – Note: This product conforms to ISO 1179-1 and to ISO 228-1

Linear drives DGC-GF, with plain-bearing guide

Technical data

Dimensions

Download CAD data → www.festo.com

∅ 50/63

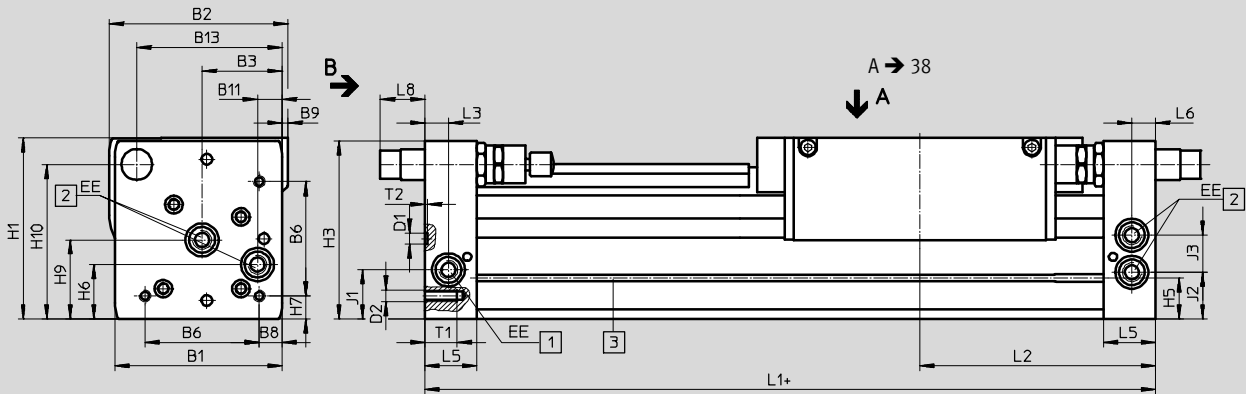

View B

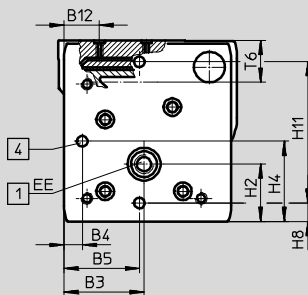

+ plus stroke length

1 Supply port options on 2 sides

2 Supply port options on 2 sides, for supply port at one end

3 Sensor slot for proximity sensor

4 Mounting hole for foot mounting HPC

- Note

The linear drive is actuated at the right end or at both ends by default.

The linear drive can be actuated at the left end or at both ends by specifying the order code DL in the modular product system.

Linear drives DGC-GF, with plain-bearing guide

Technical data

∅	B1	B2	B3	B4	B5	B6	B8	B9	B11	B12	B13	D1 ∅ H7	D2
[mm]					±0.05								
50	113	126.5	60	8	52.8	81.6	12	-	21	24	97	9	M8
63	142	149	68	15.5	68	97	19.5	5	21	30	123.5	9	M10

∅	EE	H1	H2	H3	H4	H5	H6	H7	H8	H9	H10	H11	J1
[mm]												±0.05	
50	G¼	124.5	38.5	122.5	52.8	29.3	36	12	8	53	104.5	100	30.5
63	G¾	153.5	48.5	151	68	34.8	46	19.5	15.5	67	131	120	41.5

∅	J2	J3	L1	L2	L3	L5	L6	L8			T1	T2	T6	Stroke tolerance
								PPV	YSR	YSRW				
[mm]												+0.2		
50	30.5	28	350	175	17	41	17	0	31	36.3	24	2.1	30.4	0 ... 2.5
63	39.5	31.5	400	200	20	44	20	0	38.3	48.3	27.5	2.1	36.2	

· || - Note: This product conforms to ISO 1179-1 and to ISO 228-1

Linear drives DGC-GF, with plain-bearing guide

Technical data

FESTO

Dimensions

Download CAD data → www.festo.com

Slide

∅ 18

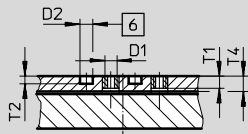

View A

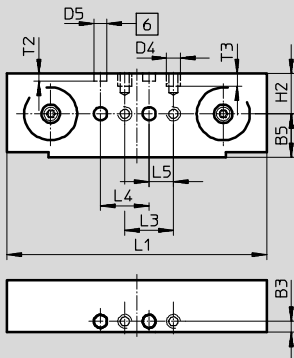

- 5 Hole for centring sleeve ZBH
- 6 Hole for centring pin ZBS

∅ 25

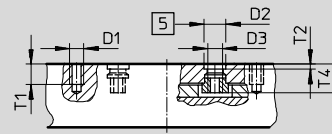

View A

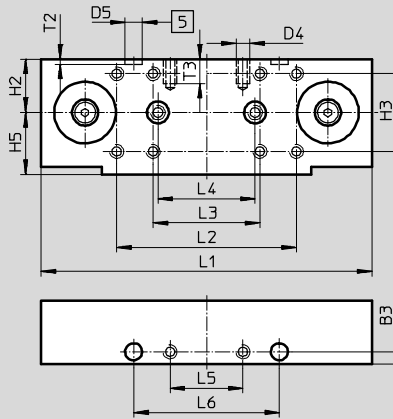

∅	B3	D1	D2	D3	D4	D5	H2	H3	H4	H5	L1
[mm]	±0.05		∅ H7			∅ H7			±0.03	±0.1	±0.1
18	4.5	M5	5	-	M5	5	16.5	-	-	18	107
25	5	M5	9	M6	M5	7	22	32±0.2	-	25.5	136

∅	L2	L3	L4	L5	L6	L7	T1	T2	T3	T4
[mm]	±0.1		±0.03	±0.1	±0.05	±0.1				
18	-	20±0.1	20	10	-	-	5	3.1±0.1	5	6.3
25	74	44±0.2	40	30	60	-	8.5	2.1+0.2	10	11.8

Linear drives DGC-GF, with plain-bearing guide

Technical data

Dimensions

Download CAD data → www.festo.com

Slide

Ø 32

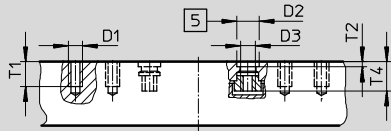

Ø 40

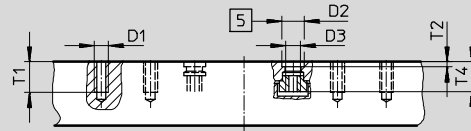

View A

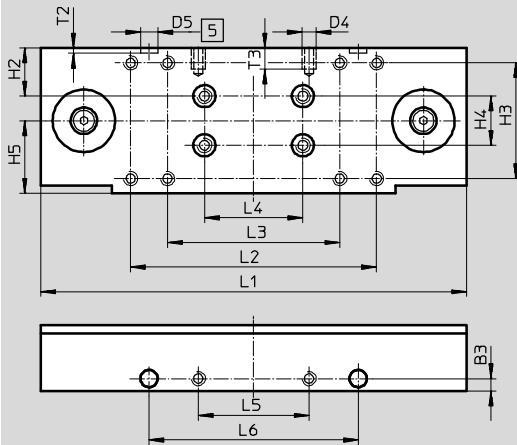

View A

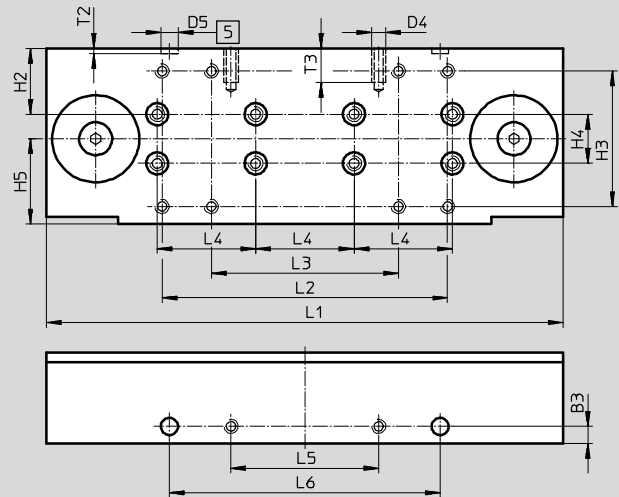

5 Hole for centring sleeve ZBH

Ø	B3	D1	D2	D3	D4	D5	H2	H3	H4	H5	L1
[mm]	±0.05		Ø H7			Ø H7			±0.03	±0.1	±0.1
32	5	M5	9	M6	M5	7	19.5	47±0.2	20	29.5	173
40	7	M5	9	M6	M6	7	26.8	55±0.2	20	34.7	210

Ø	L2	L3	L4	L5	L6	L7	T1	T2	T3	T4
[mm]	±0.1		±0.03	±0.1	±0.05	±0.1				
32	100	70±0.2	40	45	85	–	10	2.1±0.2	8.5	11.8
40	116	76±0.2	40	60	110	–	12.5	2.1±0.2	14	12.1

Linear drives DGC-GF, with plain-bearing guide

Technical data

FESTO

Dimensions

Download CAD data → www.festo.com

Slide

Ø 50

Ø 63

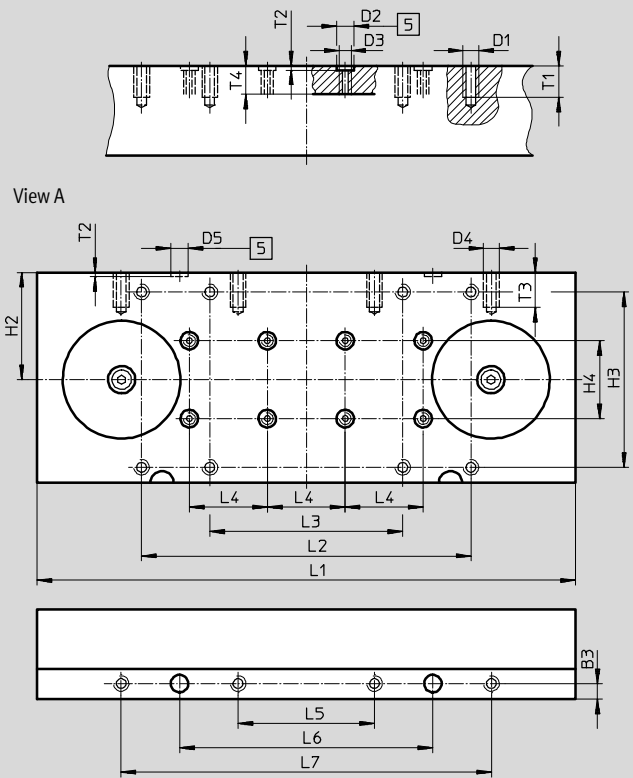
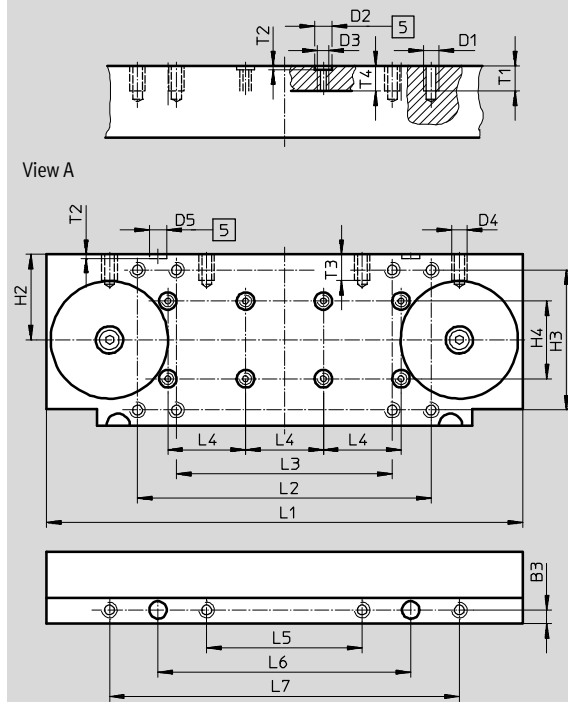

5 Hole for centring sleeve ZBH

Ø	B3	D1	D2	D3	D4	D5	H2	H3	H4	H5	L1
[mm]	±0.05		Ø H7			Ø H7			±0.03	±0.1	±0.1
50	7	M8	9	M6	M8	9	44	72±0.3	40	-	245
63	8	M8	9	M6	M8	9	55	90±0.3	40	-	276

Ø	L2	L3	L4	L5	L6	L7	T1	T2	T3	T4
[mm]	±0.1		±0.03	±0.1	±0.05	±0.1				
50	151	111±0.2	40	80	130	180	13	2.1+0.2	13.5	13
63	169	99±0.2	40	70	130	190	16	2.1+0.2	18	14.5

Linear drives DGC-GF, with plain-bearing guide

Technical data

Dimensions

Download CAD data → www.festo.com

Profile barrel

∅ 18

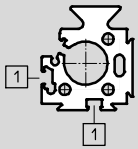

∅ 25

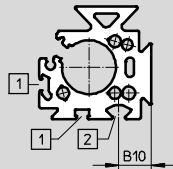

∅ 32

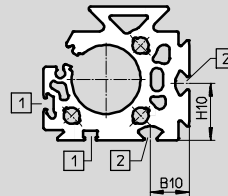

∅ 40

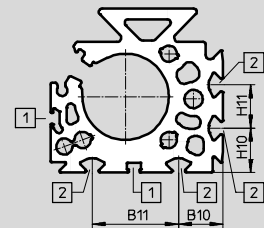

∅ 50

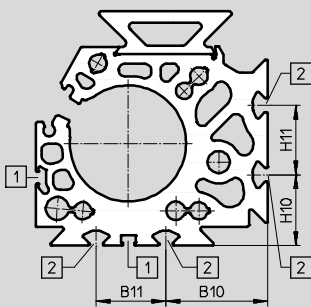

∅ 63

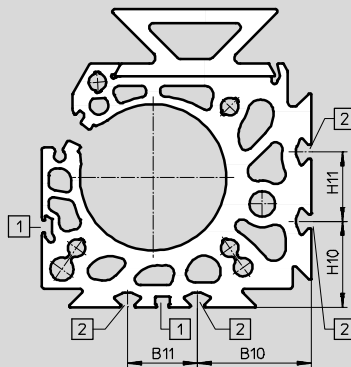

- 1 Sensor slot for proximity sensor
- 2 Mounting slot for slot nut

∅	B10	B11	H10	H11
[mm]				
25	15.23	-	-	-
32	18	-	26.5	-
40	20.5	40	20.5	20
50	43.8	30	30.5	30
63	49	30	37	30

Linear drives DGC-GF, with plain-bearing guide

Ordering data – Modular products

Order code

Mandatory data/options

-  - Note

1) End stops or shock absorbers must not be removed.

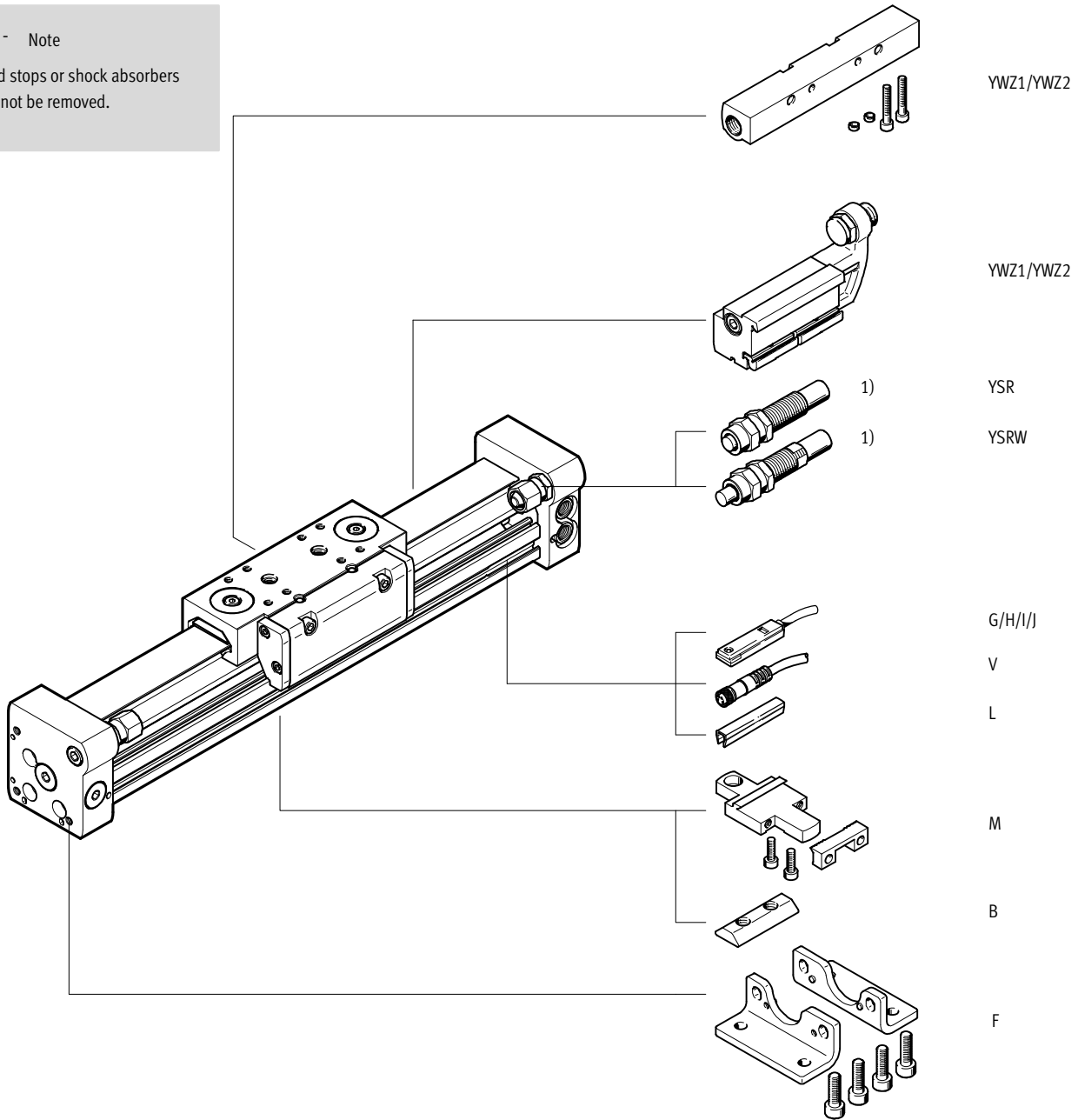

Linear drives DGC-GF, with plain-bearing guide

Ordering data – Modular products

Ordering table									
Size	18	25	32	40	50	63	Condi- tions	Code	Enter code
M Module No.	532 446	532 447	532 448	532 449	532 450	532 451			
Function	Linear drive							DGC	DGC
Piston Ø [mm]	18	25	32	40	50	63		-...	
Stroke [mm]	1 ... 3000	1 ... 8500			1 ... 5000		1	-...	
Guide	Plain-bearing guide							-GF	-GF
Cushioning	Pneumatic cushioning, adjustable at both ends							-PPV	
	Shock absorber, self-adjusting							-YSR	
	Shock absorber, self-adjusting, progressive							-YSRW	
Position sensing	For proximity sensor							-A	-A
O Compressed air supply	At right side only or at both ends								
	At left side only or at both ends							-DL	
Lubrication	Standard								
	For food industry						1	-H1	
O Accessories	Supplied loose (can be retrofitted)							ZUB-	ZUB-
Foot mounting	1							F	
Profile mounting	1 ... 9							...M	
Slot nut for mounting slot	-	1 ... 9						...B	
Proximity sensor	Cable, 2.5 m	1 ... 9						...G	
	M8 plug	1 ... 9						...H	
Proximity sensor, contactless, PNP	Cable, 2.5 m	1 ... 9						...I	
	M8 plug	1 ... 9						...J	
Cable with socket	M8, 2.5 m	1 ... 9						...V	
Slot cover for sensor slot	1 ... 9							...L	
Mechanical end position limiter	Variable end position, at one end						2	YWZ1	
	Variable end position, at both ends						2	YWZ2	
User manual	Express waiver – no operating instructions to be included (already available)							-O	

- 1 H1** Not with cushioning YSR or YSRW
2 YWZ1, YWZ2 Only with cushioning YSR or YSRW

Transfer order code

DGC - - - **GF** - - **A** - - **ZUB** - -

Linear drives DGC-KF, with recirculating ball bearing guide

Peripherals overview

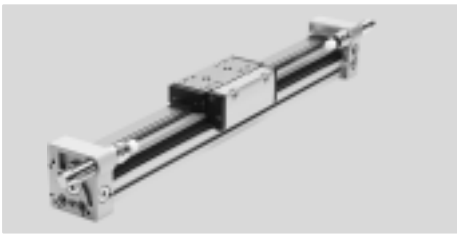

-  - Note
 1) End stops or shock absorbers must not be removed.

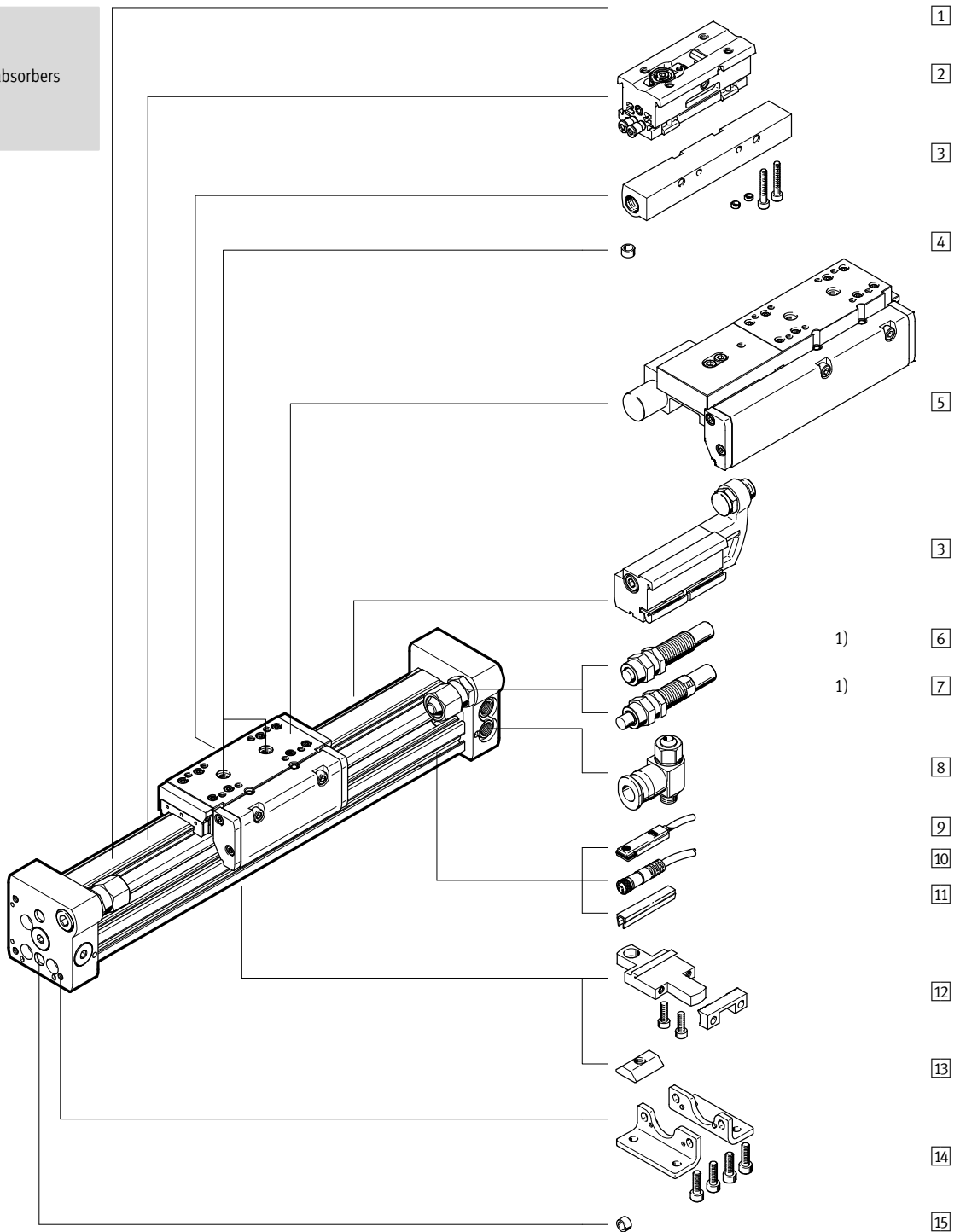

Linear drives DGC-KF, with recirculating ball bearing guide

Peripherals overview

Variants and accessories			
Type	For piston \varnothing	Brief description	→ Page/Internet
1 Linear drive DGC-KF	8 ... 63	Linear drive without accessories, with recirculating ball bearing guide	46
2 Intermediate position Z1/Z2/Z3	25, 32, 40	Enables up to three intermediate positions	76
3 Mechanical end-position limiter YWZ	18 ... 63	For variable end-position adjustment, e.g. for format adjustments	74
4 Centring pin/sleeve ¹⁾ ZBS/ZBH	8 ... 63	For centring loads and attachments on the slide	78
5 Clamping unit 1H-PN	25, 32, 40, 50	For holding loads	48
– Cushioning P	8, 12	Non-adjustable, elastic cushioning. Used only at low speeds	66
– Cushioning PPV	18 ... 63	Adjustable pneumatic end-position cushioning. Used at medium speeds	66
6 Shock absorber YSR	8 ... 63	Self-adjusting hydraulic shock absorber with spring return and linear cushioning characteristic	66
7 Shock absorber YSRW	8 ... 63	Self-adjusting hydraulic shock absorber with spring return and progressive cushioning characteristic	66
8 One-way flow control valve GRLA	8 ... 63	For regulating speed	78
9 Proximity sensor G/H/I/J	8 ... 63	For sensing the slide position	79
10 Connecting cable V	8 ... 63	For proximity sensor	79
11 Slot cover L	18 ... 63	For protecting against ingress of dirt and securing proximity sensor cables	78
12 Profile mounting M	8 ... 63	Simple and precise mounting option via dovetail connection	70
13 Slot nut B	25 ... 63	For mounting attachments	78
14 Foot mounting F	8 ... 63	For mounting on end cap	68
15 Centring pin/sleeve ZBS/ZBH	8 ... 63	For centring the drive without foot mountings (user-specific)	78

1) Included in the scope of delivery of the drive

Linear drives DGC-KF, with recirculating ball bearing guide

Type codes

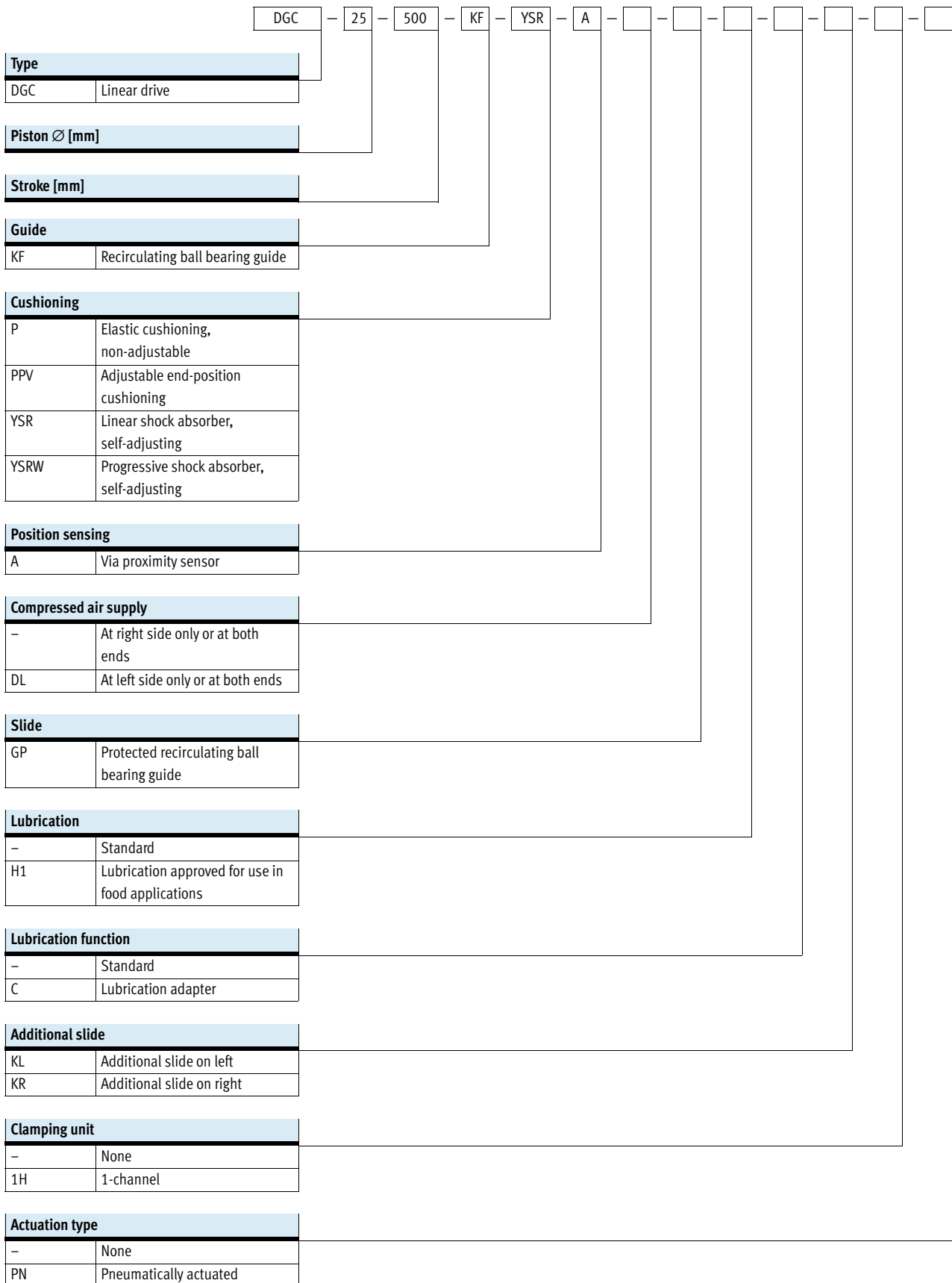

Linear drives DGC-KF, with recirculating ball bearing guide

Type codes



+ ZUB - F [] 2B 2G 2V [] [] [] []

Accessories

ZUB	Accessories enclosed separately
-----	---------------------------------

Foot mounting

F	Foot mounting
---	---------------

Profile mounting

...M	Profile mounting
------	------------------

Slot nut

...B	For mounting slot
------	-------------------

Proximity sensor

...G	With cable, 2.5 m
------	-------------------

...H	With plug
------	-----------

...I	Contactless with cable, 2.5 m
------	-------------------------------

...J	Contactless with plug
------	-----------------------

Connecting cable

...V	2.5 m
------	-------

Slot cover

...L	For sensor slot
------	-----------------

Mechanical end-position limiter

YWZ1	Variable end position, at one end
------	-----------------------------------

YWZ2	Variable end position, at both ends
------	-------------------------------------

Intermediate position

Z1	1 intermediate position
----	-------------------------

Z2	2 intermediate positions
----	--------------------------

Z3	3 intermediate positions
----	--------------------------

Manual

0	Express waiver – no operating instructions to be included
---	---

Linear drives DGC-KF, with recirculating ball bearing guide

Technical data

Function

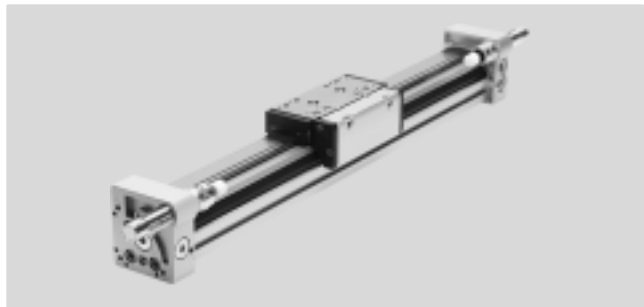
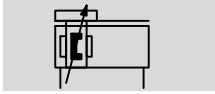

- - Diameter
8 ... 63 mm
- - Stroke length
1 ... 8,500 mm

General technical data								
Piston \varnothing	8	12	18	25	32	40	50	63
Stroke [mm]	1 ... 1,300		1 ... 1,900		1 ... 3,000		1 ... 8,500	
Pneumatic connection	M5			G $\frac{1}{8}$		G $\frac{1}{4}$		G $\frac{3}{8}$
Mode of operation	Double-acting							
Design	Rodless drive							
Moment compensator principle	Slotted cylinder, mechanically coupled							
Guide	External recirculating ball bearing guide							
Mounting position	Any							
Cushioning \rightarrow 49								
DGC-...-P	Non-adjustable at both ends		-					
DGC-...-PPV	-		Adjustable at both ends					
DGC-...-YSR...	Self-adjusting at both ends							
Cushioning length with PPV cushioning [mm]	-		16.5	15.5	17.5	29.5	29.8	31.1
Position sensing	Via proximity sensor							
Type of mounting	Profile mounting							
	Foot mounting							
	Direct mounting							
Max. speed [m/s]	1	1.2	3					
Repetition accuracy [mm]	0.02 (with shock absorber YSR/YSRW)							

- - Note: This product conforms to ISO 1179-1 and to ISO 228-1

Operating and environmental conditions								
Piston \varnothing	8	12	18	25	32	40	50	63
Operating pressure [bar]	2.5 ... 8		2 ... 8			1.5 ... 8		
Operating medium	Compressed air in accordance with ISO 8573-1:2010 [7:-:-]							
Note on operating/pilot medium	Lubricated operation possible (required during subsequent operation)							
Ambient temperature ¹⁾ [°C]	-10 ... +60							
Suitability for use in the food industry ²⁾	As per manufacturer's declaration							
Corrosion resistance class CRC ³⁾	1							
ATEX	Specified types \rightarrow www.festo.com							

1) Note operating range of proximity sensors

2) Additional information www.festo.com/sp \rightarrow User documentation.

3) CRC1: Corrosion resistance class to Festo standard 940 070

Components with light corrosion exposure. Protection for transport and storage. Components without significant decorative function or surface, e.g. installed out of sight internally or behind covers.

Forces [N]								
Piston \varnothing	8	12	18	25	32	40	50	63
Theoretical force at 6 bar	30	68	153	295	483	754	1,178	1,870
Impact energy in the end positions	\rightarrow 49							

Linear drives DGC-KF, with recirculating ball bearing guide

Technical data

Weight [g]								
Piston Ø	8	12	18	25	32	40	50	63
DGC-...								
Basic weight with 0 mm stroke	225	391	975	2,113	2,837	6,996	13,342	22,220
Additional weight per 10 mm stroke	11	16	31	49	74	117	153	236
Moving load	77	149	331	732	1,146	2,330	4,511	8,225
DGC-...-1H-PN – With clamping unit								
Basic weight with 0 mm stroke	–	–	–	3,134	4,272	12,009	19,394	–
Additional weight per 10 mm stroke	–	–	–	49	74	117	153	–
Moving load	–	–	–	1,405	2,059	5,494	8,411	–

Adjustable end-position range d [mm]

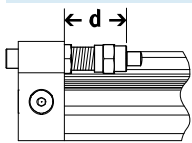

- Note

The permissible kinetic energy decreases if the stroke is reduced with PPV adjustable cushioning at both ends.

Piston Ø	8	12	18	25	32	40	50	63
Cushioning								
DGC-...-P/PPV	11.3 ... 16.3	12.7 ... 17.7	13.8 ... 15.8	21.1 ... 25.1	25.2 ... 30.2	28.7 ... 33.7	28.7 ... 33.7	38.8 ... 43.8
DGC-...-P/PPV-GP	–	–	16.9 ... 18.9	23.6 ... 27.6	25.2 ... 30.2	34.7 ... 39.7	–	–
DGC-...-YSR/YSRW	12.8 ... 22.8	14 ... 24	14.5 ... 34.5	22.5 ... 47.5	27.3 ... 52.3	31 ... 56	31 ... 56	41 ... 76

Materials

Sectional view

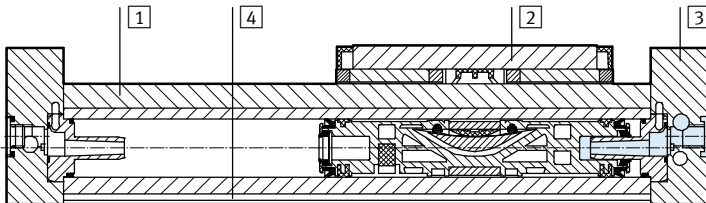

Linear drives

1	Guide rail	High-alloy steel
2	Slide	High-alloy steel
3	End cap	Anodised aluminium
4	Cylinder barrel	Anodised aluminium
–	Piston seal	Polyurethane
–	Sealing band/cover band	Polyurethane
Note on materials		RoHS-compliant, free of copper and PTFE

Influence of ferritic materials on proximity sensors

Ferritic materials (steel parts or panels) directly next to the proximity sensors can cause sensing

malfunctions. The following safety distances must be observed.

The distance depends on the position of the proximity sensor (see 1 and 2).

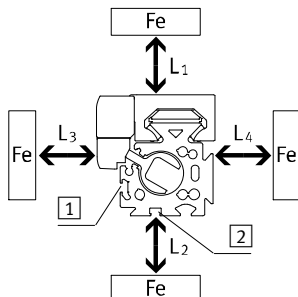

Piston Ø		8	12	18	25	32	40	50	63
Distance L1	1 [mm]	0	0	0	0	0	0	0	0
	2 [mm]	–	–	0	0	0	0	0	0
Distance L2	1 [mm]	20	10	10	10	0	0	0	0
	2 [mm]	–	–	25	25	25	25	25	25
Distance L3	1 [mm]	30	25	25	25	25	25	25	25
	2 [mm]	–	–	10	10	0	0	0	0
Distance L4	1 [mm]	0	0	0	0	0	0	0	0
	2 [mm]	–	–	0	0	0	0	0	0

Linear drives DGC-KF, with recirculating ball bearing guide

Technical data

Characteristic load values

The indicated forces and torques refer to the centre of the slide surface.

These values must not be exceeded during dynamic operation. Special attention must be paid to the cushioning phase.

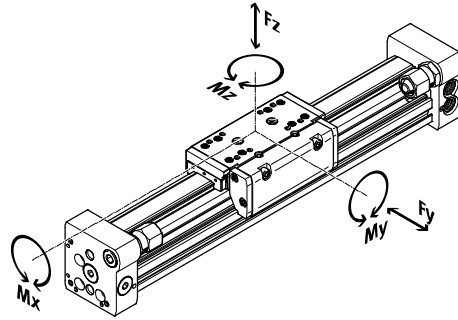

If the drive is simultaneously subjected to several of the indicated forces and torques, the following equation must be satisfied in addition to the indicated maximum loads:

$$\frac{F_y}{F_{y_{max.}}} + \frac{F_z}{F_{z_{max.}}} + \frac{M_x}{M_{x_{max.}}} + \frac{M_y}{M_{y_{max.}}} + \frac{M_z}{M_{z_{max.}}} \leq 1$$

Permissible forces and torques

Piston Ø		8	12	18	25	32	40	50	63
F _y _{max.}	[N]	300	650	1,850	3,050	3,310	6,890	6,890	15,200
F _z _{max.}	[N]	300	650	1,850	3,050	3,310	6,890	6,890	15,200
M _x _{max.}	[Nm]	1.7	3.5	16	36	54	144	144	529
M _y _{max.}	[Nm]	4.5	10	51	97	150	380	634	1,157
M _z _{max.}	[Nm]	4.5	10	51	97	150	380	634	1,157

Technical data – Clamping unit

Dimensions → 62

Size		25	32	40	50
Pneumatic connection		M5	M5	M5	M5
Clamping type		Clamping via spring force, released via compressed air			
Static holding force	[N]	320	500	1,200	1,200
Max. number of emergency braking operations ¹⁾ at reference energy	[Nm]	–	–	750	750
Number of clamping operations under nominal load	[million switching cycles]	0.45	0.55	0.05	0.05

1) Emergency braking refers to braking the effective load if the drive axis loses power.

Operating and environmental conditions – Clamping unit

Operating medium		Compressed air according to ISO 8573-1:2010 [7:4:4]
Operating pressure		
Clamping unit opened	[bar]	4.5 ... 8
Clamping unit closed	[bar]	Pressureless
Ambient temperature	[°C]	–10 ... +60

Linear drives DGC-KF, with recirculating ball bearing guide

Technical data

Maximum permissible piston speed v as a function of effective load m and distance r_{max} from centre of gravity of load

Piston \varnothing 8/12 with P cushioning

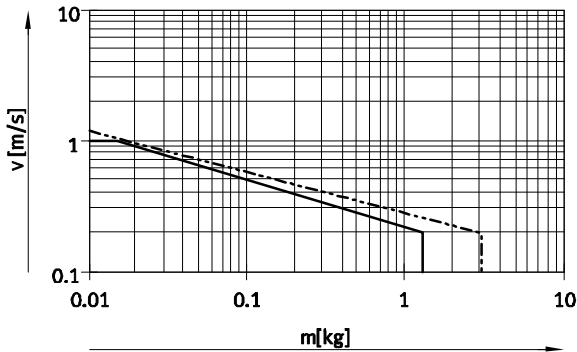

Piston \varnothing 18 ... 63 with PPV cushioning

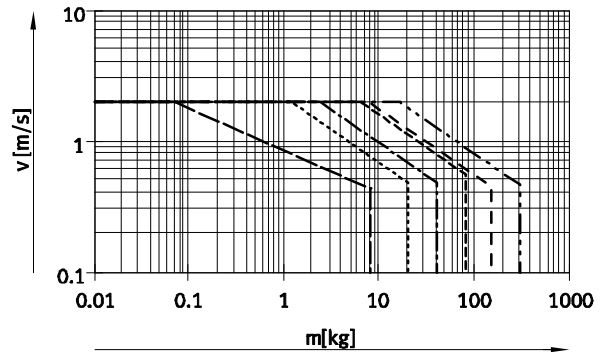

Piston \varnothing 8 ... 63 with YSR cushioning

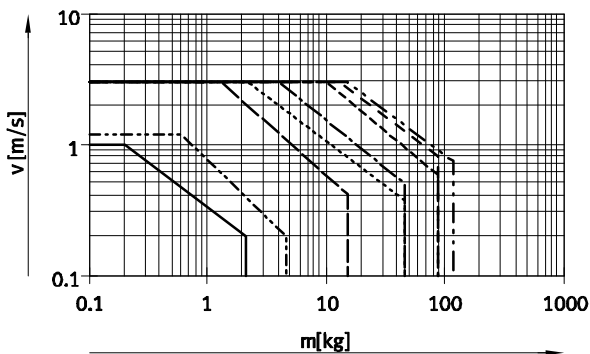

Piston \varnothing 8 ... 63 with YSRW cushioning

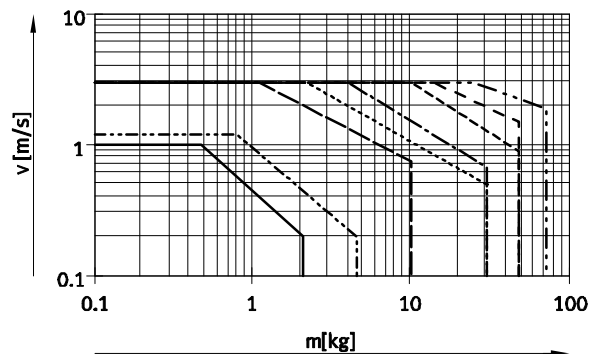

- \varnothing 8 - - - - \varnothing 18 - - - - \varnothing 40
- - - - \varnothing 12 - \varnothing 25 - - - - \varnothing 50
- · — · \varnothing 32 - - - - \varnothing 63

Note
This data represents the maximum values that can be achieved. In practice, values fluctuate relative to the position of the effective load and mounting position.

Operating range of cushioning

The end-position cushioning must be adjusted to ensure jerk-free operation. If the operating conditions are outside the permissible range, the load to be moved must be cushioned using suitable equipment (shock absorbers, stops, etc.), preferably at the centre of gravity of the load.

Note
To avoid distortion in the slide, the bearing surfaces of the attachments must maintain a flatness of at least 0.01 mm.

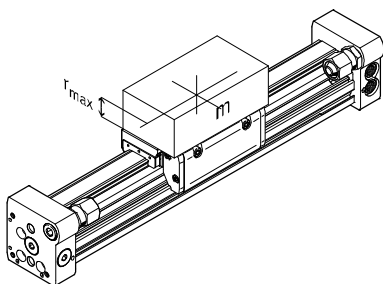

The specifications apply to a horizontal mounting position:

Piston \varnothing	8	12	18	25	32	40	50	63
Distance r_{max} [mm]	25	35	35	50	50	50	50	50

Linear drives DGC-KF, with recirculating ball bearing guide

FESTO

Technical data

Number of profile mountings MUC as a function of force due to weight F and support spacing l

In order to limit deflection in the case of large strokes, the drive may need to be supported. The following graphs

help to determine the maximum permissible support spacing as a

function of mounting position, force due to weight and normal force.

Horizontal mounting position

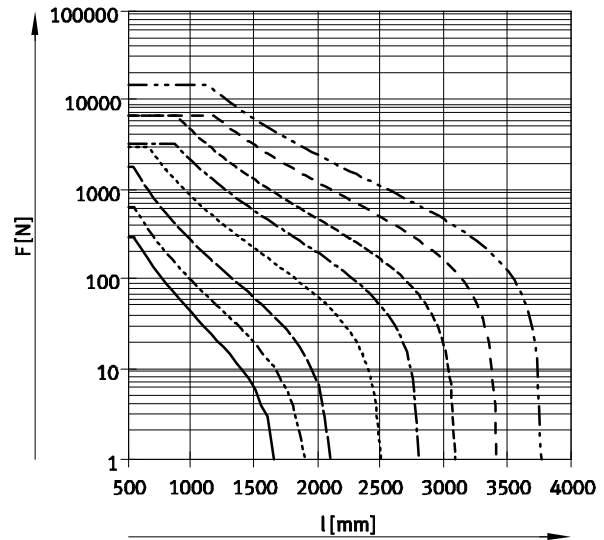
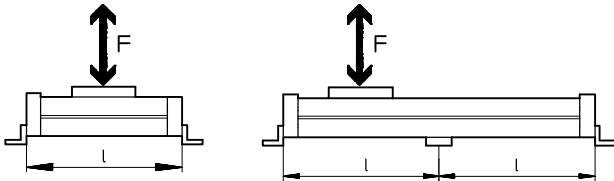

Vertical mounting position

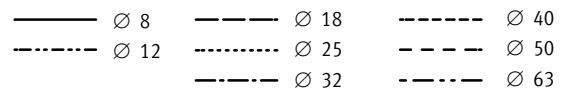
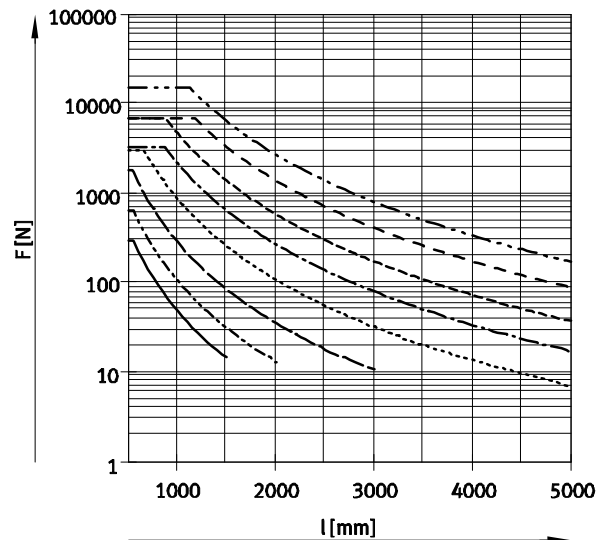
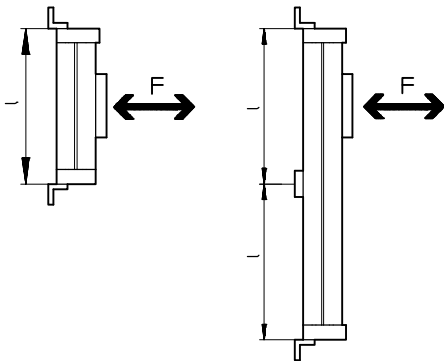

Example:

The drive DGC-25-1500 is subjected to a force of 300 N in a horizontal mounting position.

The drive has an overall length of:
 $l = \text{stroke length} + L1$
 (see dimensions)
 $= 1,500 \text{ mm} + 200 \text{ mm}$
 $= 1,700 \text{ mm}$

According to the graph, the max. support spacing for the drive DGC-25 with a force of 300 N is 1,300 mm.

In this example, profile mountings are required as the max. support spacing (1,300 mm) is smaller than the overall length of the drive (1,700 mm).

Linear drives DGC-KF, with recirculating ball bearing guide

Technical data

Central lubrication

The lubrication adapter enables the guide of the linear drive DGC-KF to be permanently lubricated in applications in humid or wet ambient conditions using semi or fully automatic relubrication devices.

- For piston \varnothing 25, 32, 40, 63
- The modules are suitable for oils and greases
- The dimensions of the linear drive DGC-KF are the same with and without central lubrication modules
- Both lubrication adapters must be connected
- There are three connection options on each side
- Can be used in combination with:
 - Standard slide GK
 - Additional slide KL, KR
- Cannot be used in combination with:
 - Protected recirculating ball bearing guide GP

Slide dimensions
→ 60

Order code C in the modular product system → 67

Connection options

Only the connection at the rear or on the top can be used in combination with shock absorbers in the end caps.

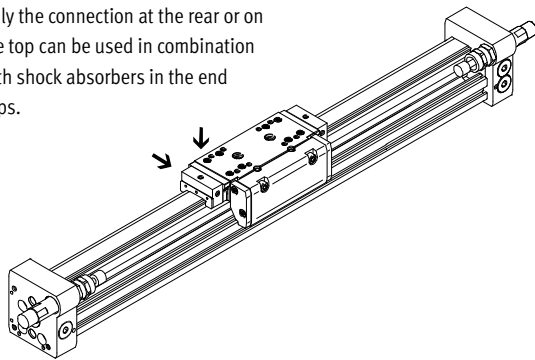

Only the connection on the front or top can be used in combination with shock absorber retainer DADP.

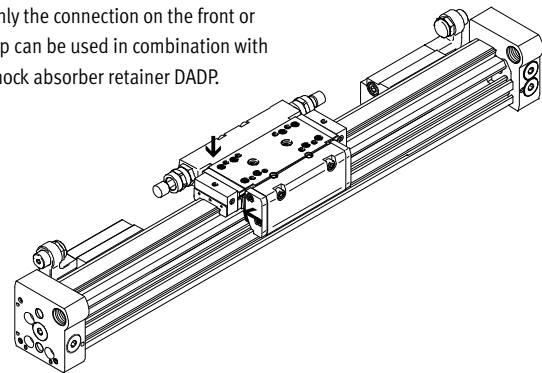

Connection option for customer design

The drawing opposite shows the connection option on the top lubrication interface using a customer design.

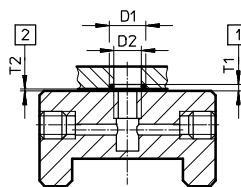

- D1 8^{+0.2} mm
- D2 6 mm
- T1 0.6_{-0.05} mm
- T2 0.1^{+0.2} mm
- O-ring \varnothing 6x1 mm (DIN3771)

- 1 Slot depth for O-ring
- 2 Required air gap

Additional dimensions → 60

Structure of a central lubrication system

A central lubrication system requires various additional components. The illustration shows different options (using a hand pump, pneumatic container pump or electric container pump) required as a minimum for designing a central lubrication system. Festo does not sell these additional components, however they can be obtained from the following companies:

- Lincoln
- Bielomatik
- SKF (Vogel)

Festo recommends these companies because they can supply all the necessary components.

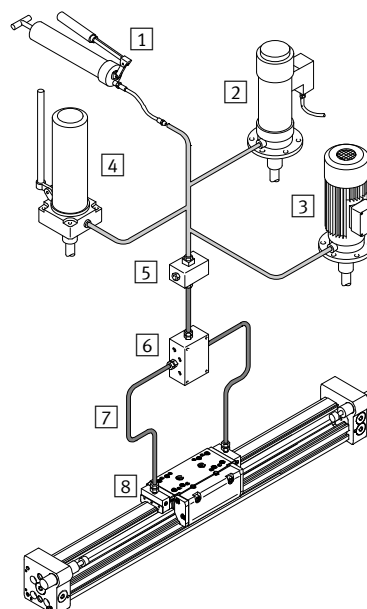

- 1 Hand pump
- 2 Pneumatic container pump
- 3 Electric container pump
- 4 Manually operated container pump
- 5 Nipple block
- 6 Distributor block
- 7 Tubing or piping
- 8 Fittings

Linear drives DGC-KF, with recirculating ball bearing guide

Technical data

FESTO

Dimensions

Download CAD data → www.festo.com

∅ 8 and 12

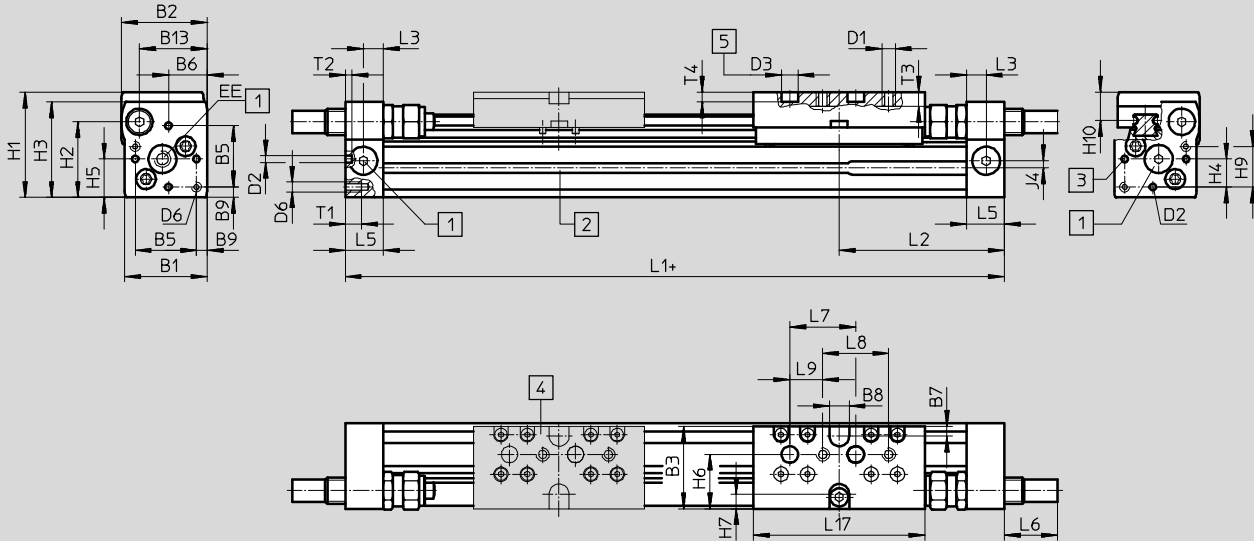

+ = plus stroke length

- 1 Supply port
options on 3 sides
- 2 Sensor slot for proximity
sensor
- 3 Mounting hole for foot
mounting or centring pin
- 4 Additional slide KL
- 5 Hole for centring pin ZBS

Linear drives DGC-KF, with recirculating ball bearing guide

Technical data

∅	B1	B2	B3	B5	B6	B7	B8	B9	B13	D1	D2	D3	D6
[mm]							±0.05	±0.1			∅ H8	∅ H7	
8	25	26	25	18.6	11.7	3	6	3.2	20.5	M4	2	5	M3
12	30.2	31	31	20.6	13.5	3	8	4.8	25	M4	2	5	M4

∅	EE	H1	H2	H3	H4	H5	H6	H7	H9	H10	J4	L1	L2
[mm]													
8	M5	32	23	29	8.5	11.7	16.5	4.5	12.3	8.7	2.2	100	50.1
12	M5	37.5	28.5	34.5	8.7	13.5	20.5	5	14.7	9.8	3	125	62.1

∅	L3	L5	L6			L7	L8	L9	L17	T1	T2	T3	T4	Stroke tolerance
			P	YSR	YSRW									
[mm]						±0.03	±0.1	±0.1					+0.2	
8	6	11.5	0	16	16.2	20	20	10	52	5	2	4.3	3	0 ... 1.7
12	8	16	0	11.3	12.3	20	20	10	65	6	2	5	3	

Profile barrel

∅ 8

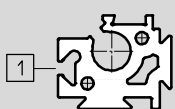

∅ 12

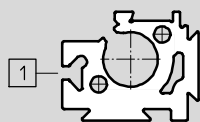

1 Sensor slot for proximity sensor

Linear drives DGC-KF, with recirculating ball bearing guide

Technical data

FESTO

Dimensions

Download CAD data → www.festo.com

Ø 18 ... 40

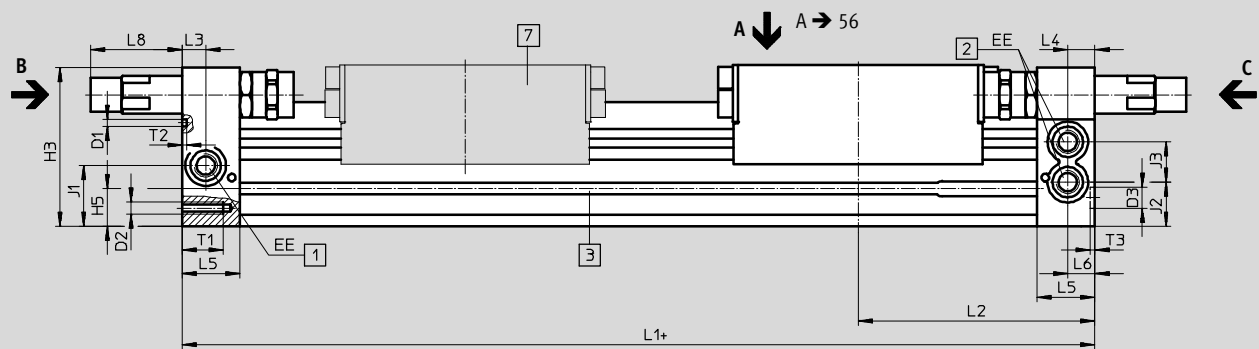

View C

Ø 18 ... 40

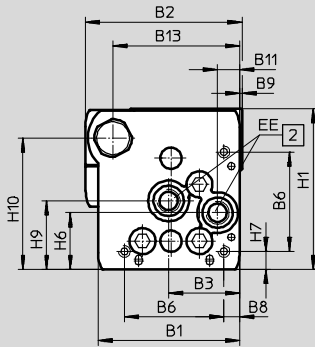

View B

Ø 18

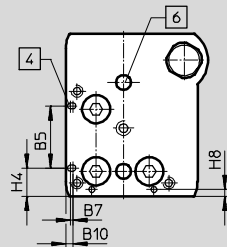

Ø 25 ... 40

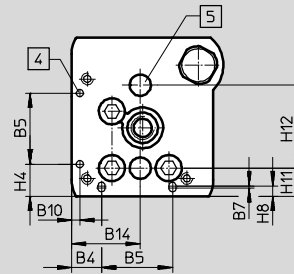

Ø 18 ... 40

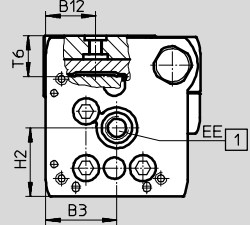

Ø 50/63

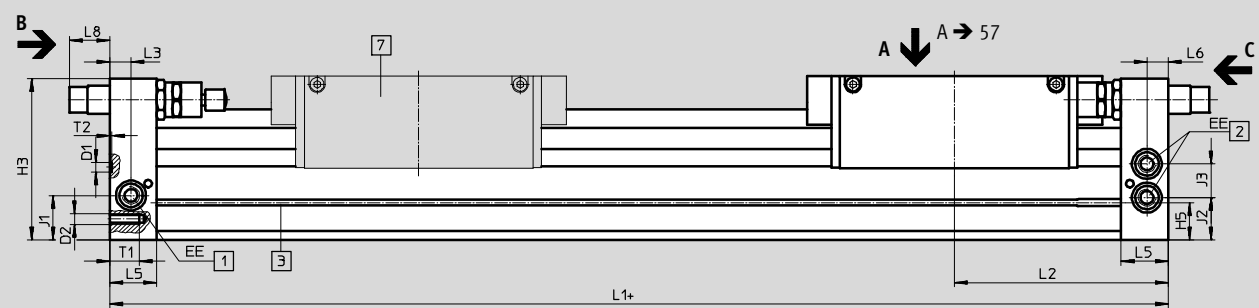

View C

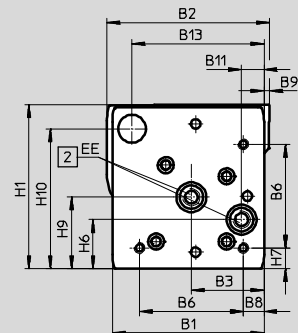

View B

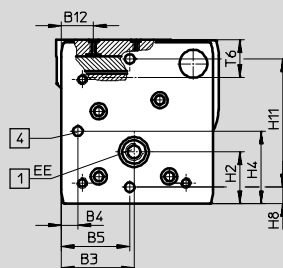

+ = plus stroke length

- 1 Supply port options on 2 sides
- 2 Supply port options on 2 sides, for supply port at one end
- 3 Sensor slot for proximity sensor
- 4 Mounting hole for foot mounting HPC
- 5 Hole for centring sleeve ZBH
- 6 Hole for centring pin ZBS
- 7 Additional slide

- Note

The linear drive is actuated at the right end or at both ends by default. The linear drive can be actuated at the left end or at both ends by specifying the order code DL in the modular product system.

Linear drives DGC-KF, with recirculating ball bearing guide

Technical data

∅ [mm]	B1	B2	B3	B4	B5 ±0.05	B6	B7	B8	B9	B10	B11
18	44.5	49.9	19.5	8.8	21	31	0.8	3.8	1	2.4	5.5
25	59.8	66	30	12.65	30	42	1	6.65	1	3.5	9.3
32	73	79	38.5	5.7	63.1	57.5	–	8.5	1.5	14	14.9
40	91	98.5	45	17.2	55	65	–	12.2	2	8	16.5
50	113	126.5	60	8	52.8	81.6	–	12	–	–	21
63	142	149	68	15.5	68	97	–	19.5	5	–	21

∅ [mm]	B12	B13	B14	D1 ∅	D2	D3 ∅ H7	EE	H1	H2	H3
18	15.5	39	19.5	2±0.05	M4	5	M5	56.3	23.1	55
25	21	53	29	3±0.05	M5	9	G $\frac{1}{8}$	68	29	67
32	18	65	38.5	3±0.05	M6	9	G $\frac{1}{8}$	78.5	30	77
40	24.8	80.5	45	4±0.05	M6	9	G $\frac{1}{4}$	99.5	41.5	97.5
50	24	97	–	9 ^{H7}	M8	–	G $\frac{1}{4}$	124.5	38.5	122.5
63	30	123.5	–	9 ^{H7}	M10	–	G $\frac{3}{8}$	153.5	48.5	151

∅ [mm]	H4 ±0.2	H5	H6	H7	H8	H9	H10	H11	H12 ±0.05	J1
18	9.6	13.4	20	4.6	2.4	25.2	46	8.5±0.15	30	20
25	13.65	15.8	24	7.65	4.5	29	55.5	12±0.15	35	26.1
32	5.7	17	27.7	8.5	14	35.2	63.8	11.45±0.15	50	30
40	17.2	25	36.5	12.2	8	44	81.5	15±0.15	60	35
50	52.8	29.3	36	12	8	53	104.5	100±0.05	–	30.5
63	68	34.8	46	19.5	15.5	67	131	120±0.05	–	41.5

∅ [mm]	J2	J3	L1			L2			L3	L4
			KF	KF-GP	1H-PN	KF	KF-GP	1H-PN		
18	16.5	11	150	157	–	74.5	78	–	5.7	5.8
25	18.6	17	200	205	271	100	102.5	100	10.5	10.6
32	22	18.5	250	250	320.5	124.8	124.8	124.8	14.5	14.5
40	26	26	300	312	458	150	156	150	14.6	14.6
50	30.5	28	350	–	555.8	175	–	–	17	–
63	39.5	31.5	400	–	–	200	–	–	20	–

∅ [mm]	L5	L6	L8			T1	T2	T3	T6	Stroke tolerance
			PPV	YSR	YSRW					
18	15	5.5	0	29.9	32.4	9	2	3.1 ^{+0.2}	15	0 ... 2.5
25	24.5	10.6	0	35.6	38.6	17.5	2	2.1 ^{+0.2}	17.3	
32	30.5	14.5	0	19.5	28	15	2	2.1 ^{+0.2}	20	
40	33.5	14.6	0	38.5	43.5	20	3	2.1 ^{+0.2}	25.7	
50	41	17	0	31	36.3	24	2.1 ^{+0.2}	–	28.75	
63	44	20	0	38.3	48.3	27.5	2.1 ^{+0.2}	–	36.1	

– || – Note: This product conforms to ISO 1179-1 and to ISO 228-1

Linear drives DGC-KF, with recirculating ball bearing guide

Technical data

FESTO

Dimensions

Download CAD data → www.festo.com

Slide

Ø 18

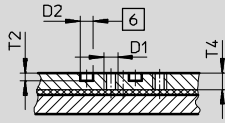

View A

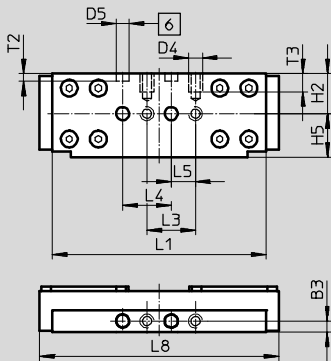

Ø 25

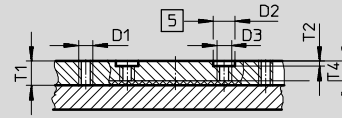

View A

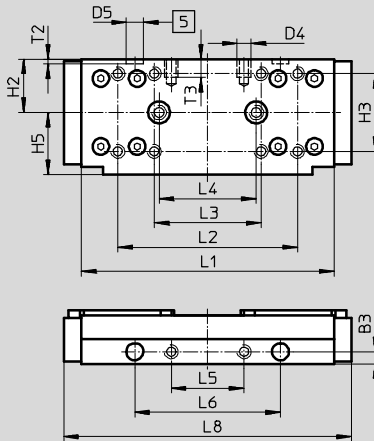

Ø 32

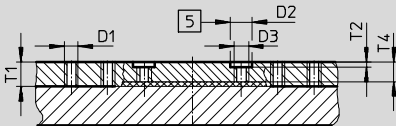

View A

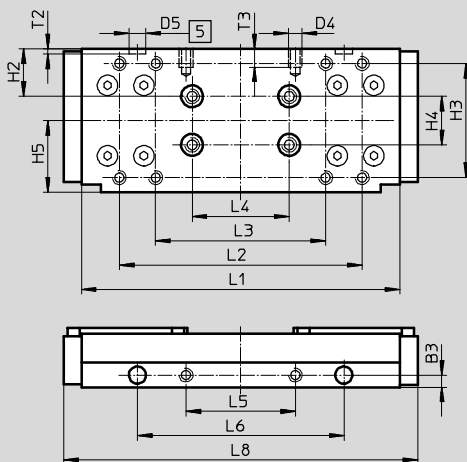

Ø 40

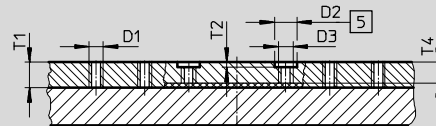

View A

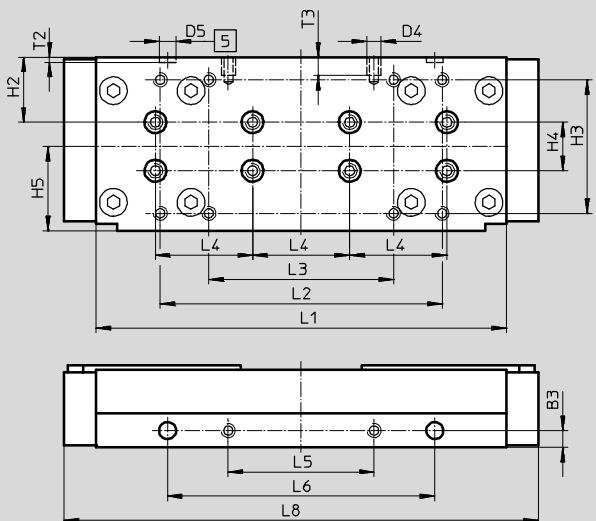

5 Hole for centring sleeve ZBH

6 Hole for centring pin ZBS

Linear drives DGC-KF, with recirculating ball bearing guide

Technical data

Dimensions

Download CAD data → www.festo.com

Slide

Ø 50

Ø 63

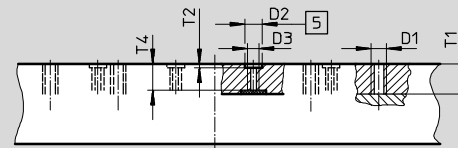
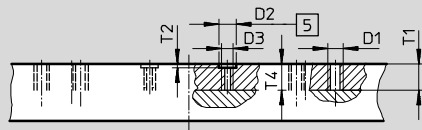

View A

View A

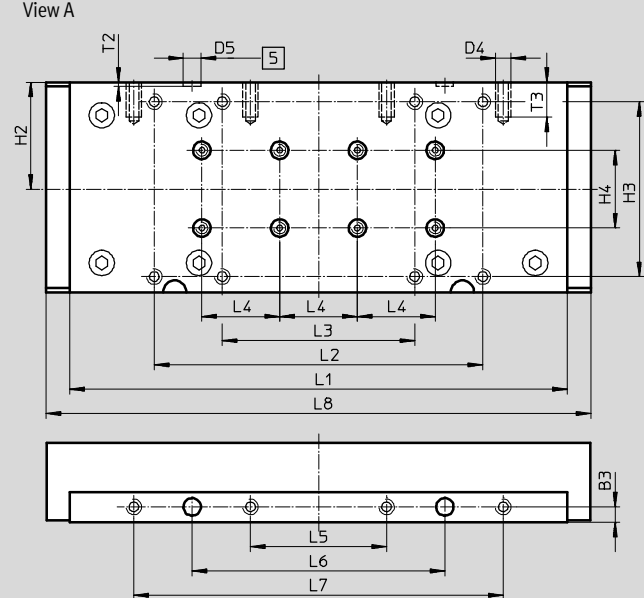
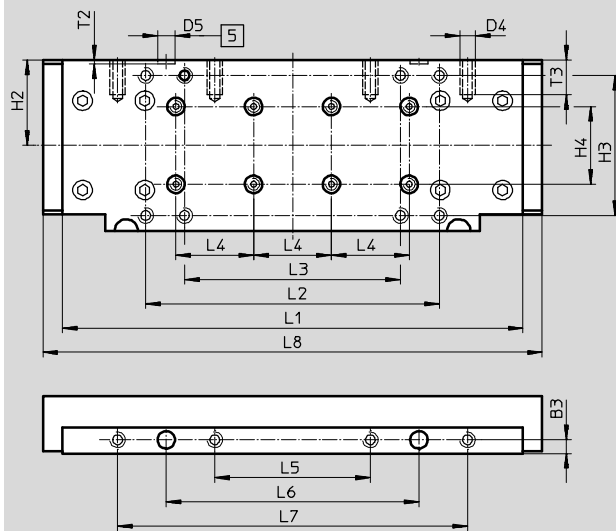

- 5 Hole for centring sleeve ZBH
- 6 Hole for centring pin ZBS

Ø	B3	D1	D2	D3	D4	D5	H2	H3	H4	H5	L1
[mm]	±0.05		Ø H7			Ø H7			±0.03	±0.1	
18	4.5	M5	5	–	M5	5	16.5	–	–	18	88±0.1
25	5	M5	9	M6	M5	7	22	32±0.2	–	25.5	104±0.2
32	5	M5	9	M6	M5	7	19.5	47±0.2	20	29.5	131±0.2
40	7	M5	9	M6	M6	7	26.8	55±0.2	20	34.7	169±0.2
50	7	M8	9	M6	M8	9	44	72±0.3	40	–	237±0.1
63	8	M8	9	M6	M8	9	55	90±0.3	40	–	256±0.1

Ø	L2	L3	L4	L5	L6	L7	L8	T1	T2	T3	T4
[mm]	±0.2		±0.03	±0.1	±0.05	±0.1					
18	–	20±0.1	20	10	–	–	99	–	3.1±0.1	7.5	6.7
25	74	44±0.2	40	30	60	–	118.5	10	2.1±0.2	7.5	8
32	100	70±0.2	40	45	85	–	145.7	10	2.1±0.2	7.5	8
40	116	76±0.2	40	60	110	–	195.4	10.5	2.1±0.2	7.5	8.5
50	151	111±0.2	40	80	130	180	256.8	13.5	2.1±0.2	18	13.5
63	169	99±0.2	40	70	130	190	280	15.5	2.1±0.2	18	13.6

Linear drives DGC-KF, with recirculating ball bearing guide

Technical data

FESTO

Dimensions

Download CAD data → www.festo.com

Slide, variant GP – Protected recirculating ball bearing guide

Ø 18

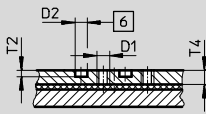

View A

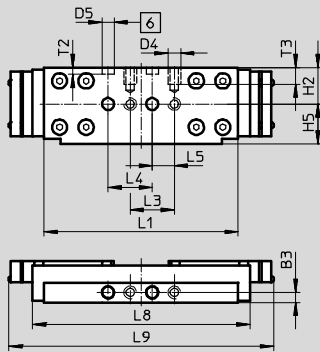

Ø 25

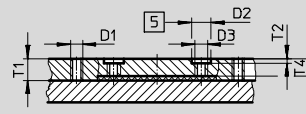

View A

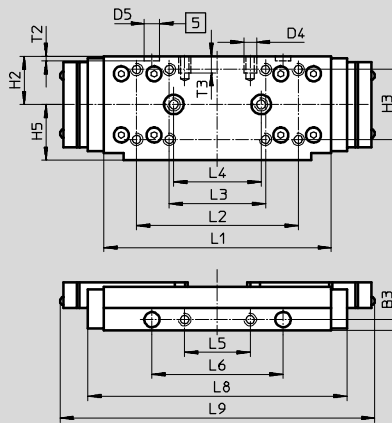

Ø 32

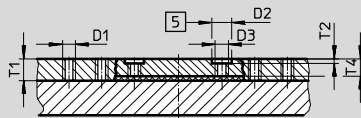

View A

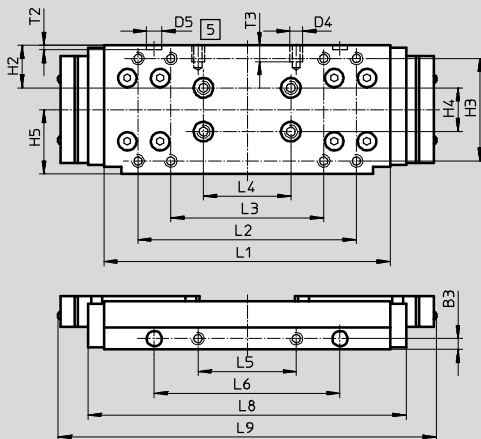

Ø 40

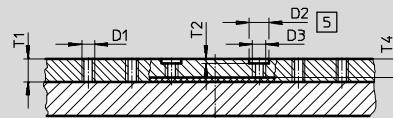

View A

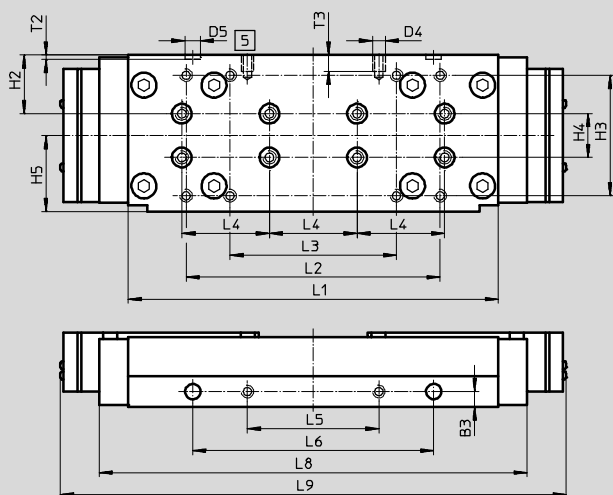

5 Hole for centring sleeve ZBH

6 Hole for centring pin ZBS

Linear drives DGC-KF, with recirculating ball bearing guide

Technical data

∅ [mm]	B3 ±0.05	D1	D2 ∅ H7	D3	D4	D5 ∅ H7	H2	H3
18	4.5	M5	5	–	M5	5	16.5	–
25	5	M5	9	M6	M5	7	22	32±0.2
32	5	M5	9	M6	M5	7	19.5	47±0.2
40	7	M5	9	M6	M6	7	26.8	55±0.2

∅ [mm]	H4 ±0.03	H5 ±0.1	L1	L2 ±0.2	L3	L4 ±0.03	L5 ±0.1	L6 ±0.05
18	–	18	88±0.1	–	20±0.1	20	10	–
25	–	25.5	104±0.2	74	44±0.2	40	30	60
32	20	29.5	131±0.2	100	70±0.2	40	45	85
40	20	34.7	169±0.2	116	76±0.2	40	60	110

∅ [mm]	L7 ±0.1	L8	L9	T1	T2	T3	T4
18	–	99	120	–	3.1±0.1	7.5	6.7
25	–	118.5	144	10	2.1±0.2	7.5	8
32	–	145.7	173	10	2.1±0.2	7.5	8
40	–	195.4	231	10.5	2.1±0.2	7.5	8.5

Linear drives DGC-KF, with recirculating ball bearing guide

Technical data

FESTO

Dimensions

Download CAD data → www.festo.com

Slide, variant C – Lubrication adapter

Ø 25

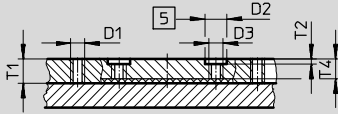

View A

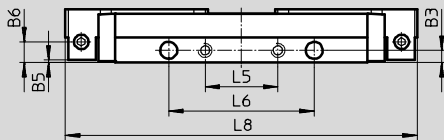
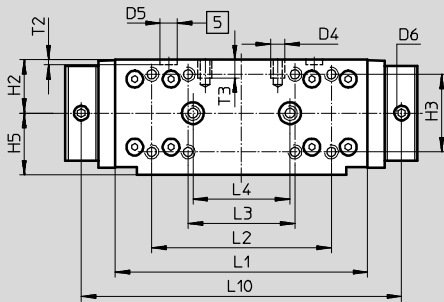

Ø 32

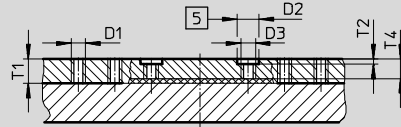

View A

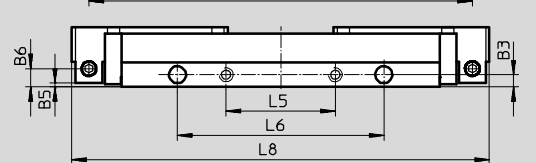
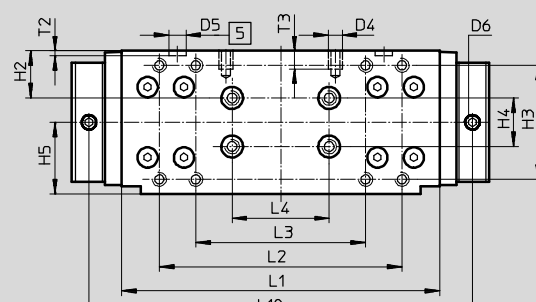

Ø 40

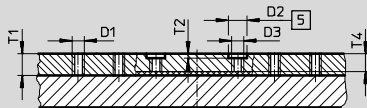

View A

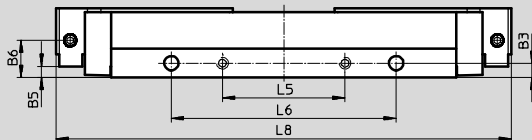
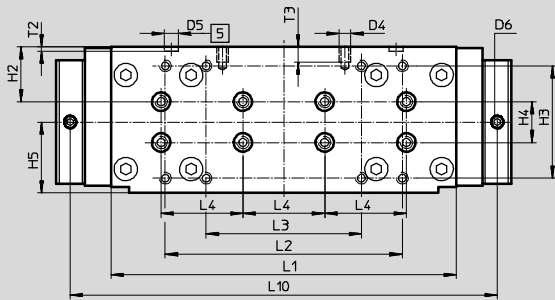

Ø 63

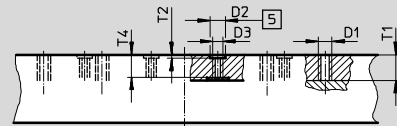

View A

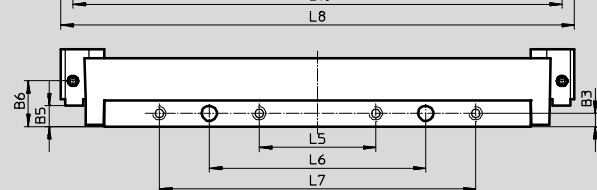
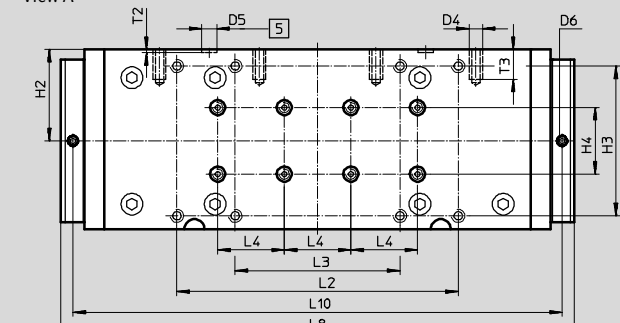

5 Hole for centring sleeve ZBH

Linear drives DGC-KF, with recirculating ball bearing guide

FESTO

Technical data

∅	B3	B5	B6	D1	D2	D3	D4	D5	D6	H2	H3	H4	H5
[mm]	±0.05	±0.05			∅ H7			∅ H7				±0.03	±0.1
25	5	1	8.5	M5	9	M6	M5	7	M6x1	22	32±0.2	-	25.5
32	5	1.5	7.5	M5	9	M6	M5	7	M6x1	19.5	47±0.2	20	29.5
40	7	18.2	18.2	M5	9	M6	M6	7	M6x1	26.8	55±0.2	20	34.7
63	8	12.5	27.5	M8	9	M6	M8	9	M6x1	55	90±0.3	40	-

∅	L1	L2	L3	L4	L5	L6	L7	L8	L10	T1	T2	T3	T4
[mm]		±0.2	±0.2	±0.03	±0.1	±0.05	±0.1				±0.2		
25	104±0.2	74	44	40	30	60	-	145	132	10	2.1	7.5	8
32	131±0.2	100	70	40	45	85	-	172	158	10	2.1	7.5	8
40	169±0.2	116	76	40	60	110	-	223	209	10.5	2.1	7.5	8.5
63	256±0.1	169	99	40	70	130	190	308.4	293.8	15.5	2.1	18	13.6

Profile barrel

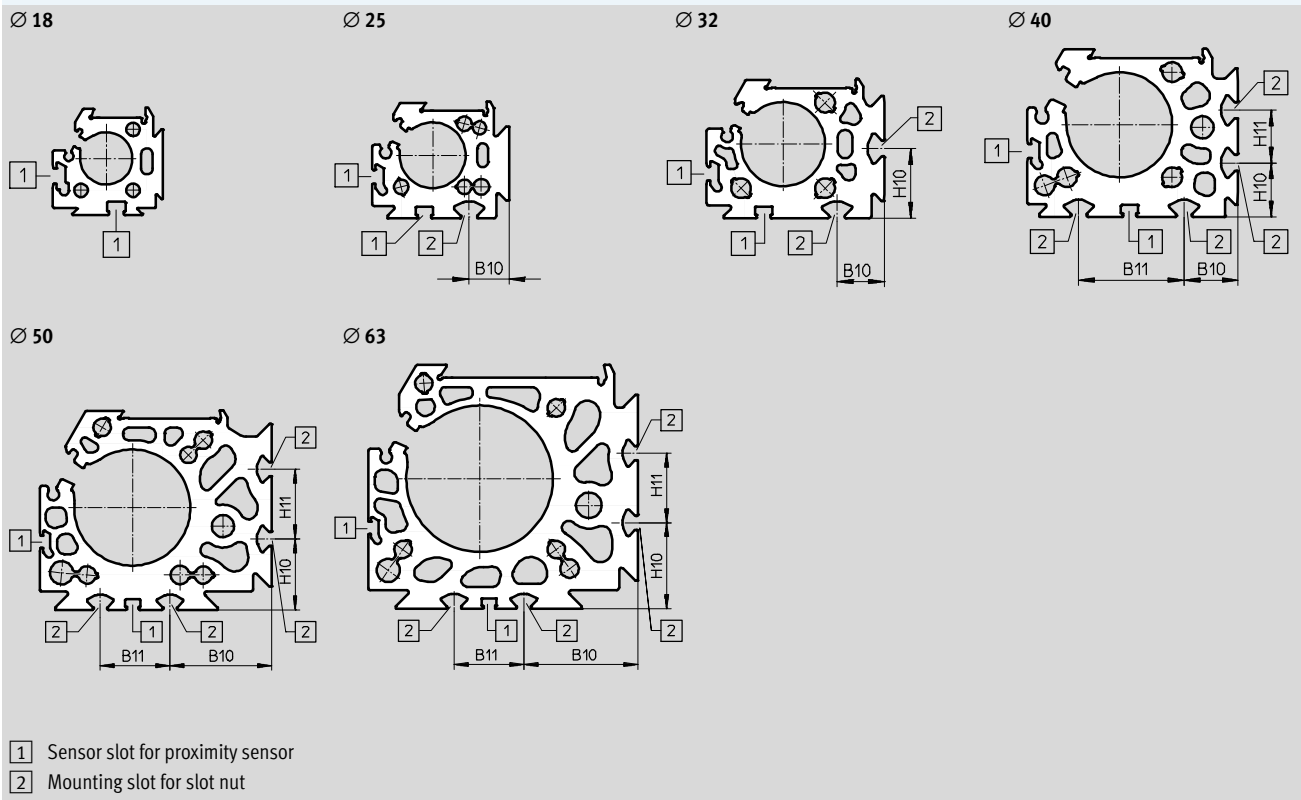

∅	B10	B11	H10	H11
[mm]				
25	15.23	-	-	-
32	18	-	26.5	-
40	20.5	40	20.5	20
50	43.8	30	30.5	30
63	49	30	37	30

Linear drives DGC-KF, with recirculating ball bearing guide

Technical data

FESTO

Dimensions

Download CAD data → www.festo.com

1H – With clamping unit

Size 25/32

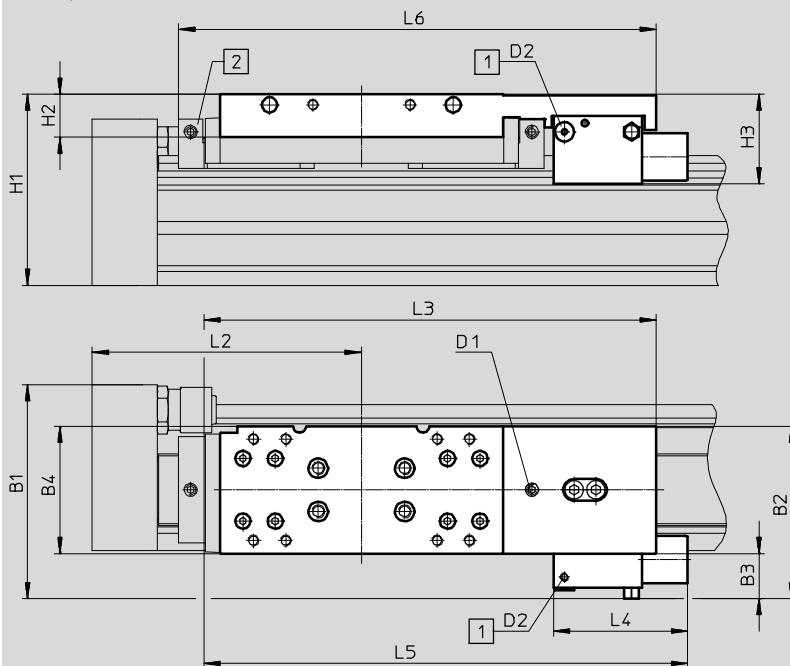

- Note

Total length L1 with stroke = 0 mm

→ 54

1 Supply port

2 Lubrication adapter

Type	B1	B2	B3	B4	H1	H2	H3	D1	D2	L2	L3	L4	L5	L6
DGC-25-...-1H-PN	83.6	64.9	17.6	47.5	79	21	39.5	M6	M5	100	182.3	63	198	-
DGC-25-...-C-1H-PN														193.8
DGC-32-...-1H-PN	99.9	79.9	20.9	59	88.5	20	41.5	M6	M5	124.8	209.4	62	223.9	-
DGC-32-...-C-1H-PN														221

Linear drives DGC-KF, with recirculating ball bearing guide

Technical data

Dimensions

Download CAD data → www.festo.com

1H – With clamping unit

Size 40/50

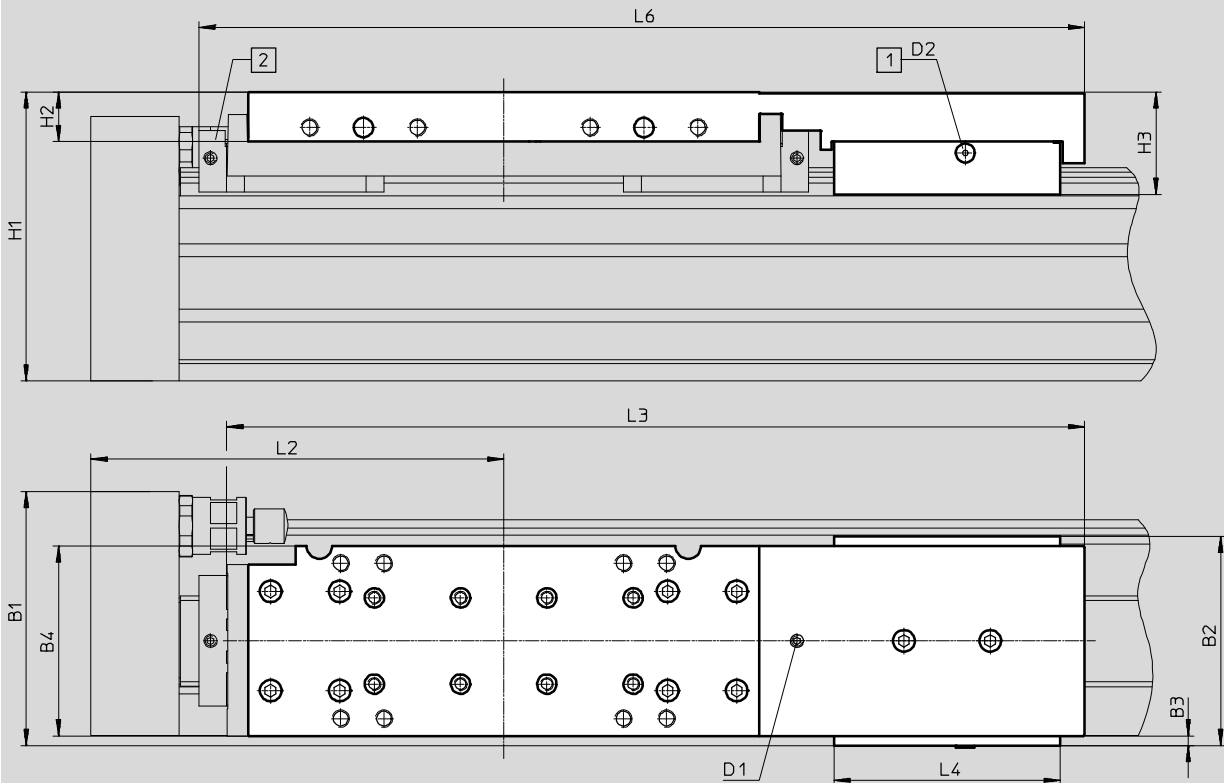

- Note

Total length L1 with stroke = 0 mm

→ 54

1 Supply port

2 Lubrication adapter

Type	B1	B2	B3	B4	H1	H2	H3	D1	D2	L2	L3	L4	L6
DGC-40-...-1H-PN	109.9	97	11.7	69.4	113.5	28	48.9	M6	M5	150	331.2	105	-
DGC-40-...-C-1H-PN													345.7
DGC-50-...-1H-PN	117.8	97	4.5	88	134	23	47.4	M6	M5	175	397.6	105	-
DGC-50-...-C-1H-PN													412.1

Linear drives DGC-KF, with recirculating ball bearing guide

Ordering data – Modular products

Order code

Mandatory data/options

-  - Note

1) End stops or shock absorbers must not be removed.

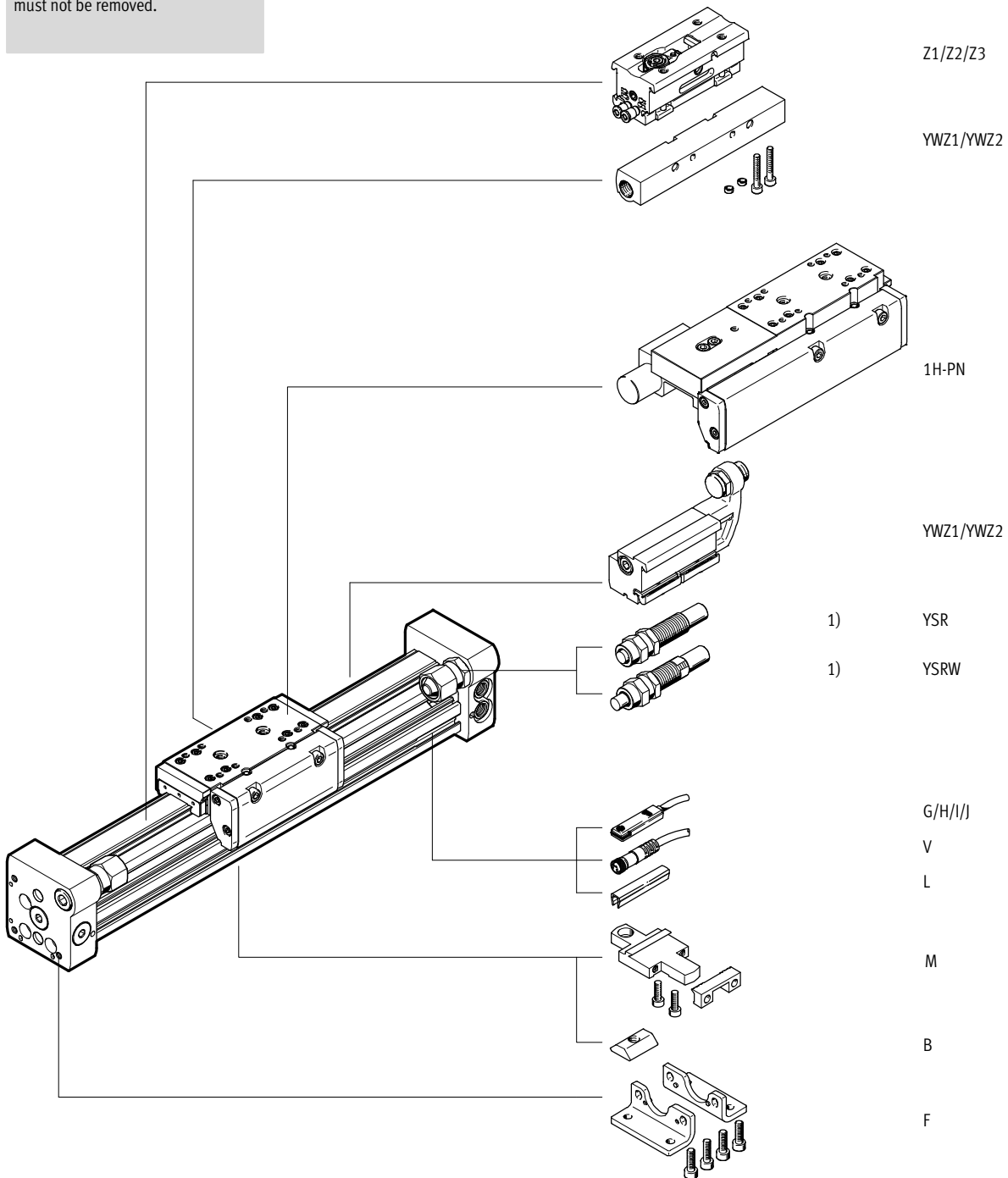

Linear drives DGC-KF, with recirculating ball bearing guide

Ordering data – Modular products

Order code

KL/KR – With additional slide

GP – With protected recirculating ball bearing guide

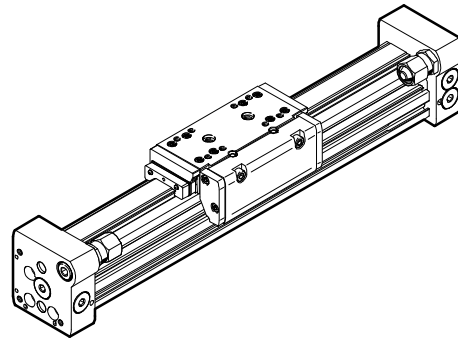
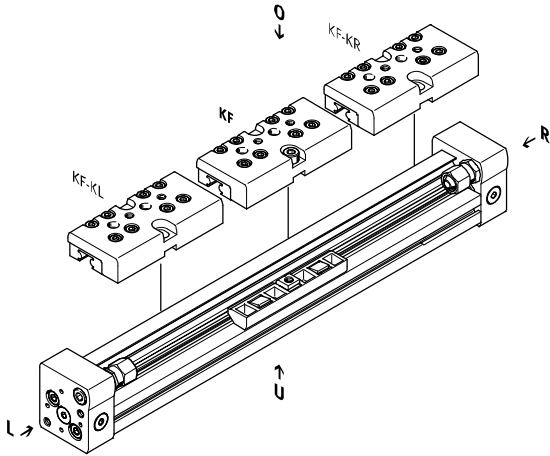

Working stroke reduction when ordering an additional slide KL or KR

With a linear drive DGC with additional slide, the working stroke is reduced by the length of the additional

slide and the distance between both slides.

Given:

DGC-12-500-...

L = 20 mm

L17 = 65 mm

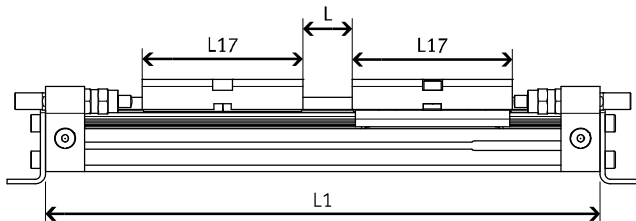

∅ [mm]	8	12	18	25	32	40	50	63
L17	52	65	99	118.5	145.7	195.4	256.8	280

The working stroke is reduced to
 $415 \text{ mm} = 500 \text{ mm} - 20 \text{ mm} - 65 \text{ mm}$

Linear drives DGC-KF, with recirculating ball bearing guide

Ordering data – Modular products

Ordering table											
Size	8	12	18	25	32	40	50	63	Condi- tions	Code	Enter code
M Module No.	530 906	530 907	532 446	532 447	532 448	532 449	532 450	532 451			
Function	Linear drive									DGC	DGC
Piston Ø [mm]	8	12	18	25	32	40	50	63		-...	
Stroke [mm]	1 ... 1,300	1 ... 1,900	1 ... 3,000	1 ... 8,500			1 ... 5,000			-...	
Guide	Recirculating ball bearing guide									-KF	-KF
Cushioning	Elastic cushioning rings/pads at both ends		-	-	-	-	-	-		-P	
	-		Pneumatic cushioning, adjustable at both ends							-PPV	
	Shock absorber, self-adjusting									-YSR	
	Shock absorber, self-adjusting, progressive									-YSRW	
Position sensing	Via proximity sensor									-A	-A
0 Compressed air supply	At right side only or at both ends										
	-		At left side only or at both ends							-DL	
Slide	-		Protected recirculating ball bearing guide			-		-		1	-GP
Lubrication	-		Standard								
	-		Lubrication approved for use in food applications						2	-H1	
Lubrication function	Standard										
	-		-		Lubrication adapter					3	-C
Additional slide on left	Additional slide, standard, on left									4	-KL
Additional slide on right	Additional slide, standard, on right									4	-KR
Clamping unit	-		-		None			-			
	-		-		1-channel			-		5	-1H
Actuation type	-		-		None			-			
	-		-		Pneumatic			-		5	-PN

- 1 GP** Not with cushioning YSR, YSRW
Not with additional slide KL, KR
- 2 H1** Not with protected version GP, cushioning YSR, YSRW or clamping unit 1H
Not with slide GP
- 3 C** For size 50 only with clamping unit 1H
- 4 KL, KR** With a linear drive DGC with additional slide, the effective stroke is reduced by the length of the additional slide and the distance between both slides
Not with cushioning PPV
- 5 1H, PN** Not with intermediate position Z1, Z2, Z3; end-position limiter YWZ1, YWZ2; protected version GP; additional slide KL, KR or lubrication H1
Only with cushioning YSRW
1H only with PN

Transfer order code

DGC - - - **KF** - - **A** - - - - - - - - - - - - -

Linear drives DGC-KF, with recirculating ball bearing guide

Ordering data – Modular products

Ordering table											
Size	8	12	18	25	32	40	50	63	Condi- tions	Code	Enter code
Accessories	Enclosed separately (can be retrofitted)									ZUB-	ZUB-
Foot mounting	1									F	
Profile mounting	1 ... 9									...M	
Slot nut for mounting slot	-	-	-	1 ... 9						...B	
Proximity sensor	2.5 m cable		1 ... 9							...G	
	M8 plug		1 ... 9							...H	
Proximity sensor, contactless, PNP	2.5 m cable		1 ... 9							...I	
	M8 plug		1 ... 9							...J	
Connecting cable	M8, 2.5 m		1 ... 9							...V	
Slot cover for sensor slot	-	-	1 ... 9							...L	
Mechanical end-position limiter	-		Variable end position, at one end					[6]	YWZ1		
	-		Variable end position, at both ends					[6]	YWZ2		
Intermediate position	-		-		1 intermediate position		-	-	[7]	-Z1	
	-		-		2 intermediate positions		-	-	[7]	-Z2	
	-		-		3 intermediate positions		-	-	[7]	-Z3	
Manual	Express waiver – no operating instructions to be included (already available)									-0	

[6] **YWZ1, YWZ2** Only with cushioning YSR or YSRW

[7] **Z1, Z2, Z3** Only with cushioning YSR or YSRW and mechanical end-position limiter YWZ1 or YWZ2

Transfer order code

- ZUB -

Linear drives DGC

Accessories

Foot mounting HPC
(order code: F)

Material:
Galvanised steel

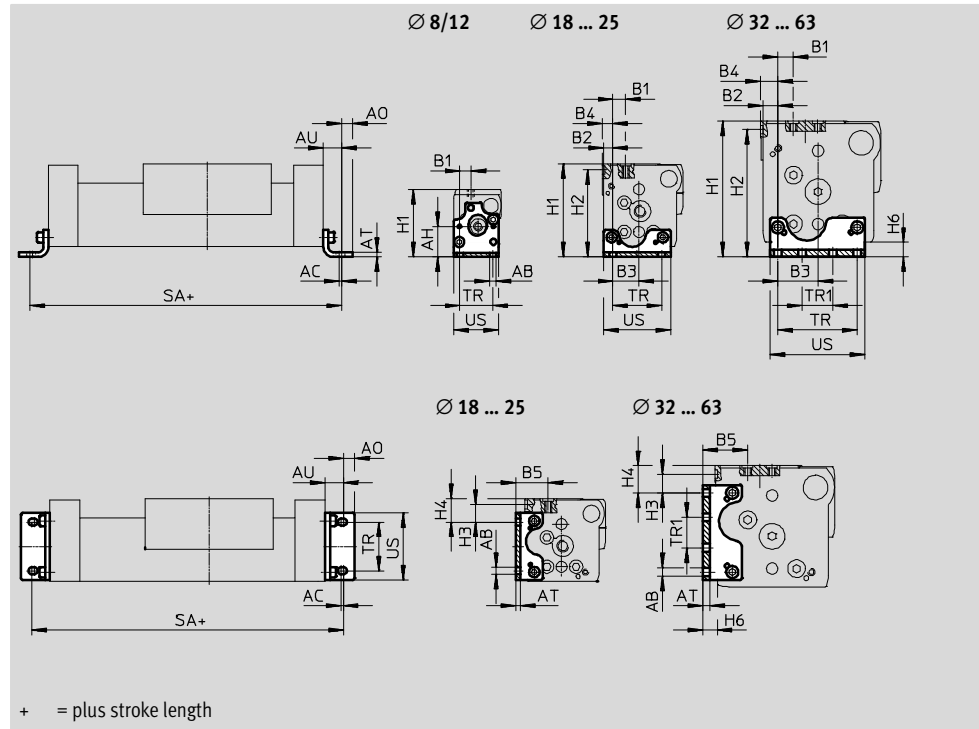

Dimensions and ordering data

For Ø [mm]	AB Ø	AC	AH	AO	AT	AU	B1		B2
							G	GF/KF	
8	3.4	1.5	16.7	3	2	9	6	6	–
12	4.5	2	18.5	4.5	2	11.5	5.4	5.4	–
18	5.5	2	–	6.75	3	13.25	15	11.2	4.3
25	5.5	2	–	9	4	15	12.5	13.35	7.65
32	6.6	2	–	10	5	19	11.5	9	9
40	6.6	2	–	10	6	20	7.6	12.6	12.2
50	9	3	–	11	8	25	12.5	12.5	11.5
63	11	3	–	13.5	8	28	17.5	17.5	12.5

For Ø [mm]	B3	B4		B5		H1	
		GF	KF	G	GF/KF	G	GF/KF
8	–	–	–	–	–	37	37
12	–	–	–	–	–	42.5	42.5
18	15.2	–	5.3	27	23.2	57.5	64
25	21.35	–	8.65	28.65	29.5	67	76.5
32	29.5	–	10.5	29.5	27	82	87.5
40	32.8	–	14.2	31.8	36.8	100	111.5
50	48.5	11.5	11.5	41	41	137	141.5
63	55.5	6.5	17.5	49	49	159	172.5

Linear drives DGC

Accessories

Dimensions and ordering data						
For Ø	H2	H3	H4		H6	SA
[mm]	GF/KF	GF/KF	G	GF/KF		-0.2
8	-	-	-	-	5	118
12	-	-	-	-	5	148
18	59.5	16	14	21.2	7.7	176.5
25	71.5	14.35	9.85	19.35	8.5	230
32	82.5	8	7.5	13	9	288
40	104.5	15.3	10.8	22.3	12	340
50	134.5	23.4	25.9	30.4	17	400
63	164.5	22	24	30	19	456

For Ø	TR	TR1	US	Weight	Part No.	Type
[mm]	±0.1	±0.1		[g]		
8	18	-	24.4	25	526385	HPC-8
12	20	-	29.6	41	526388	HPC-12
18	30	-	38.6	58	533667	HPC-18
25	40	-	55	131	533668	HPC-25
32	56.5	19.5	68	239	533669	HPC-32
40	65	25	78	348	533670	HPC-40
50	82.6	47.4	102	754	545236	HPC-50
63	111	39	133	1,245	545237	HPC-63

Linear drives DGC

Accessories

FESTO

Profile mounting MUC
(order code: M)

Material:
High-alloy steel

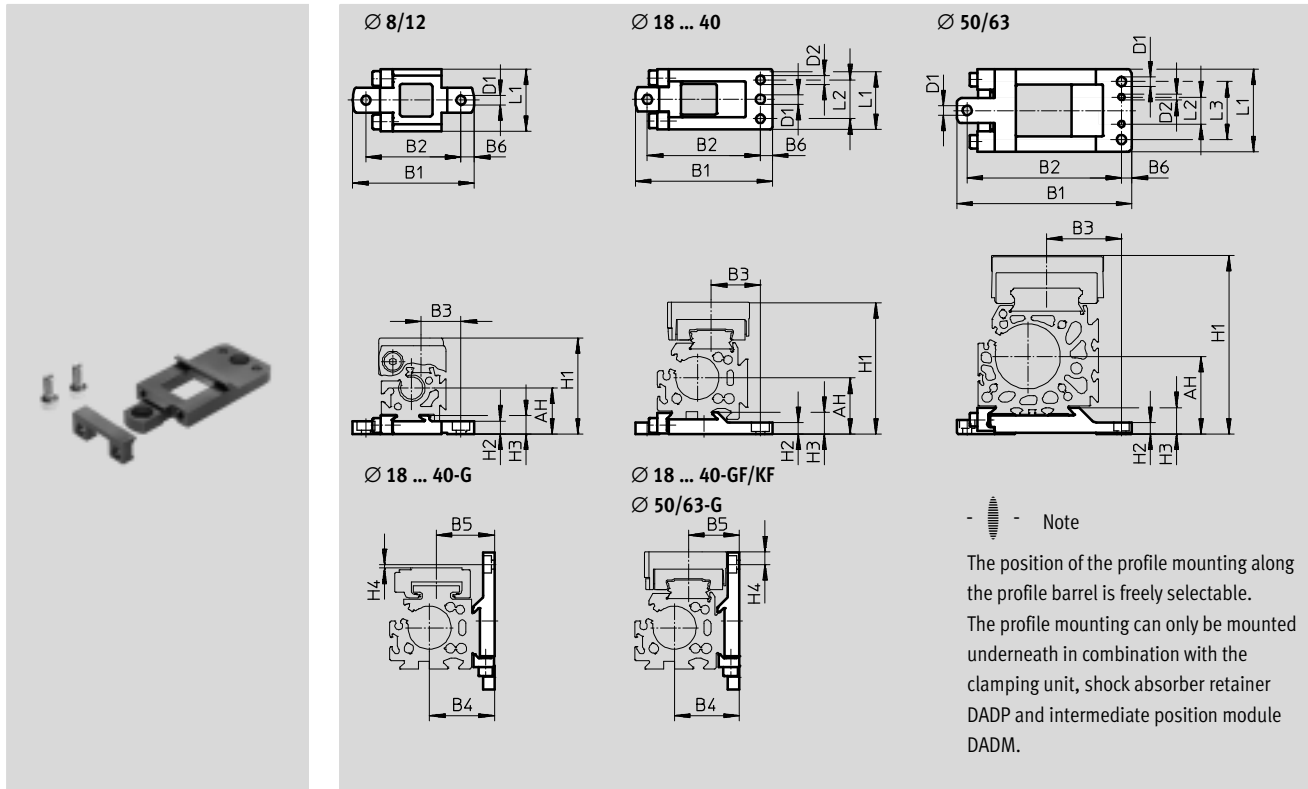

Dimensions and ordering data						
For Ø	AH	B1	B2	B3		B4
[mm]				G	GF/KF	
8	17.7	47	36.7	15.35	15.35	–
12	18.5	52.5	42.2	16.5	16.5	–
18	27.2	67.8±0.2	56±0.15	30.5	28.7	27.2
25	32.5	79.5±0.2	65.5±0.15	32.5	28.5	37.5
32	37.5	94±0.2	80±0.15	35	35	47.5
40	47	110.5±0.2	96±0.15	43	43	57
50	61	145±0.5	125±0.2	56	56	77
63	75	169±0.5	149±0.2	72.5	72.5	87

For Ø	B5		B6	D1	D2	H1	
[mm]	G	GF/KF		Ø H13	Ø H7	G	GF/KF
8	–	–	5.1	3.5	–	37	37
12	–	–	5.1	3.5	–	42.5	42.5
18	25	23.2	5.7	5.5	5	57.5	64
25	33.5	29.5	7	5.5	5	67	76.5
32	37	37	7	5.5	5	82	87.5
40	46.8	46.8	7	6.5	6	100	111.5
50	61	61	7	9	6	137	141.5
63	69	69	10	9	6	159	172.5

Linear drives DGC

Accessories

Dimensions and ordering data					
For Ø	H2	H3	H4		L1
[mm]			G	GF/KF	
8	5	7	–	–	24
12	4.5	7	–	–	24
18	5.7 _{-0.2}	9.9 _{±0.1}	0.1	6.4	33 _{±0.1}
25	6.5 _{-0.2}	12.5 _{±0.1}	2.07	7.43	35 _{±0.1}
32	6.5 _{-0.2}	13 _{±0.1}	1.5	4	45 _{±0.1}
40	8.5 _{-0.2}	16 _{±0.1}	0.2	11.3	60 _{±0.1}
50	11	23.5	4.7	9.2	80 _{±0.4}
63	11	25.5	1.5	15	80 _{±0.4}

For Ø	L2	L3	Weight	Part No.	Type
[mm]	±0.05	±0.2	[g]		
8	–	–	28	526384	MUC-8
12	–	–	32	526387	MUC-12
18	20.5	–	78	531752	MUC-18
25	22.5	–	113	531753	MUC-25
32	30	–	174	531754	MUC-32
40	44	–	346	531755	MUC-40
50	26	56	874	531756	MUC-50
63	26	56	1,080	531757	MUC-63

Linear drives DGC

Accessories

Driver FKC
(order code: FK)
for DGC-G

Materials:
Plate: Wrought aluminium alloy

Joint: Polyamide
Ball pin: High-alloy steel



For $\varnothing 8 \dots 40$

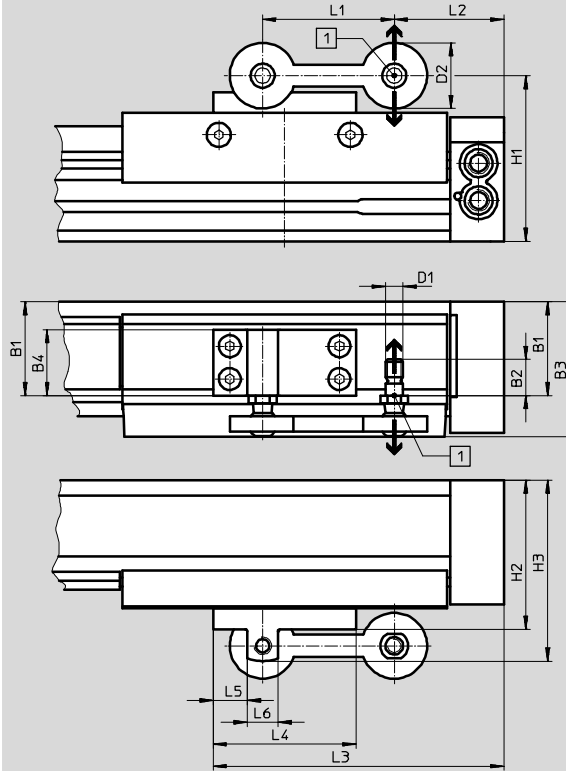

-  - Note

Compensation possible in direction of arrow.

- 1 Radial deflection:
with $\varnothing 8 \dots 40$: ± 2.5 mm
with $\varnothing 50/63$: ± 4 mm

For $\varnothing 50/63$

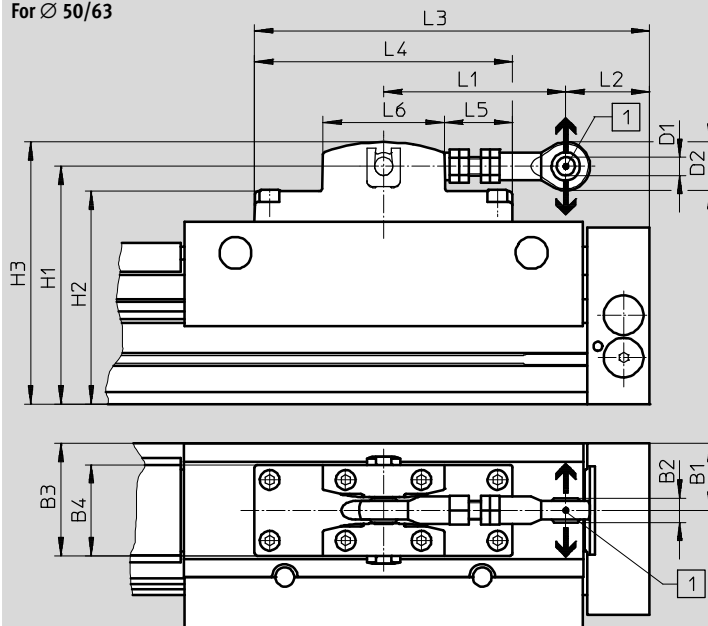

Linear drives DGC

Accessories

Dimensions and ordering data				
For Ø [mm]	Max. offset between linear drive and external guide [mm]	Max. permissible load in direction of force		Ambient temperature
		[N]		[°C]
8	±2.5	550	Backlash-free	-10 ... +60
12		550	Backlash-free	
18		1,400	Backlash-free	
25		1,400	Backlash-free	
32		1,400	Backlash-free	
40		1,400	Backlash-free	
50	±4	5,000	Low-backlash	
63		5,000	Low-backlash	

For Ø [mm]	B1	B2	B3	B4	D1	D2	H1	H2	H3	L1
8	17.5	10.2	30	16	M5	20	43.5	42	48	40
12	18.5	10.2	31	16	M5	20	49	47.5	53.5	40
18	29.3	16.5	47.8	20	M8	30	66.8	59.8	73.8	60
25	42.65	16.5	61.15	30	M8	30	75.5	68	82.5	60
32	43	16.5	61.5	30	M8	30	90	82.5	97	60
40	57.3	16.5	75.8	45	M8	30	105	97.5	113	60
50	44	16	74	60	12 ^{H7}	32	156.5	140	172.4	120 ... 125
63	50	16	80	60	12 ^{H7}	32	176.5	161.5	192.4	120 ... 125

For Ø [mm]	L2	L3	L4	L5	L6	CRC ¹⁾	Weight [g]	Part No.	Type
8	5.1	62.6	35	13	9	1	29	529350	FKC-8/12
12	17.1	74.6	35	13	9	1	29	529350	FKC-8/12
18	24.5	107	65	15.5	14	1	97	538714	FKC-18
25	50	132.5	65	15.5	14	1	119	538715	FKC-25
32	77.5	162	75	17.5	14	1	122	538961	FKC-32
40	103	187.5	75	17.5	14	1	180	538962	FKC-40
50	50 ... 55	260	170	45	80	1	1,200	545240	FKC-50/63
63	75 ... 80	260	170	45	80	1	1,200	545240	FKC-50/63

1) Corrosion resistance class 1 to Festo standard 940 070
Components requiring low corrosion resistance. Transport and storage protection. Parts that do not have primarily decorative surface requirements, e.g. in internal areas that are not visible or behind covers

Linear drives DGC

Accessories

Shock absorber retainer DADP Stop KYC

(order code: YWZ1 or YWZ2)
For DGC-GF, DGC-KF, DGC-FA

Materials: Stop
Housing: Anodised aluminium
Stop bracket: Stainless steel casting
Clamp: High-alloy steel
Free of copper and PTFE

Materials: Shock absorber retainer
Housing: Anodised aluminium
Free of copper and PTFE

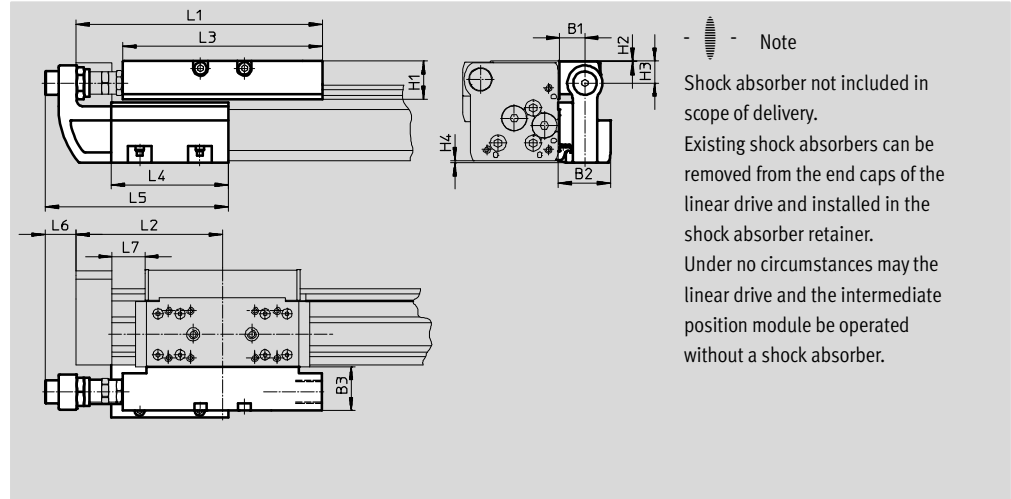

Dimensions								
For Ø [mm]		B1	B2	B3	H1	H2	H3	H4
18	GF	16	34.5	29	20.7	0.2	12.5	0.7
	KF							
25	GF	16.5	35	28	25.5	0.5	15	1.4
				KF				
32	GF	16.5	35	28	25.5	0.5	15	1.7
				KF				
40	GF	16	35.7	29	32	0.5	21.5	1.6
				KF	35			37
50	GF	25	50	41	40.5	0.5	24	0
63	GF	25	50	40	51.5	1.5	33	0

For Ø [mm]		L1	L2	L3	L4	L5	L6	L7 min.
18	GF	128	74.5	107	80	118.5	23.5	14.5
25	GF	168	100	136	80	125	20.5	22.5
32	GF	206.8	124.8	164	120	165	14.5	42.8
								KF
40	GF	255	150	210	156	220.5	31	30.8
								KF
50	GF	301	175	252	170	238	27	31
63	GF	328	200	256	200	268	24	41

Linear drives DGC

Accessories

Technical data and ordering codes

Precision adjustment

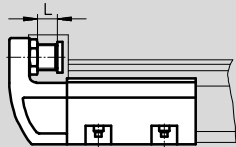

-  - Note

The stop KYC can be used in both directions.

Installation example

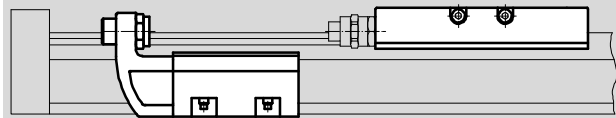

-  - Note

The stop KYC can be mounted at any position within the stroke.

For \varnothing [mm]		Max. impact force [N]	Ambient temperature [°C]	CRC ¹⁾	Weight [g]	Part No.	Type
Shock absorber retainer							
18	GF	1,100	-10 ... +80	2	140	541725	DADP-DGC-18-GF
	KF				130	541729	DADP-DGC-18-KF
25	GF	1,400			205	541726	DADP-DGC-25-GF
	KF				180	541730	DADP-DGC-25-KF
32	GF	1,700			225	541727	DADP-DGC-32-GF
	KF				215	541731	DADP-DGC-32-KF
40	GF	3,500			380	541728	DADP-DGC-40-GF
	KF				460	541732	DADP-DGC-40-KF
50	GF	3,500			890	545244	DADP-DGC-50
	KF						
63	GF	4,300			1,080	545245	DADP-DGC-63
	KF						

1) Corrosion resistance class 2 to Festo standard 940 070

Components subject to moderate corrosion stress. Externally visible parts with primarily decorative surface requirements which are in direct contact with a normal industrial environment or media such as coolants or lubricating agents

For \varnothing [mm]	Precision adjustment L [mm]	Ambient temperature [°C]	CRC ¹⁾	Weight [g]	Part No.	Type
Stop						
18	10	-10 ... +80	2	400	541691	KYC-18
25	10			560	541692	KYC-25
32	10			790	541693	KYC-32
40	15			1,525	541694	KYC-40
50	15			2,270	545242	KYC-50
63	15			2,950	545243	KYC-63

1) Corrosion resistance class 2 to Festo standard 940 070

Components subject to moderate corrosion stress. Externally visible parts with primarily decorative surface requirements which are in direct contact with a normal industrial environment or media such as coolants or lubricating agents

Linear drives DGC

Accessories

Intermediate position module DADM

(order code: Z1, Z2 or Z3)

For DGC-KF

Materials:

Housing: Anodised aluminium

Stop screw, nut:

Galvanised steel

Clamp, lever:

High-alloy steel

Free of copper and PTFE

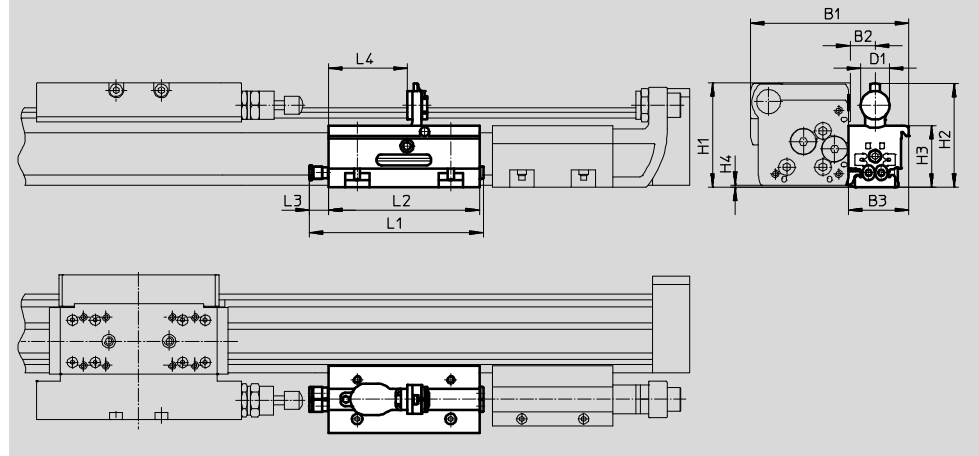

Dimensions												
For \varnothing [mm]	B1	B2	B3	D1	H1	H2	H3	H4	L1	L2	L3	L4
25	105	16.5	40	19	69.4	68.6	41	1.4	116	100	13.4	52.2
32	117.5	16.5	40	19	80.2	79.7	52	1.7	116	100	13.4	52.2
40	137.5	16	41	27	101.6	101.1	63	2.1	186	170	13.4	76.5

Minimum distance

between end stop and intermediate position

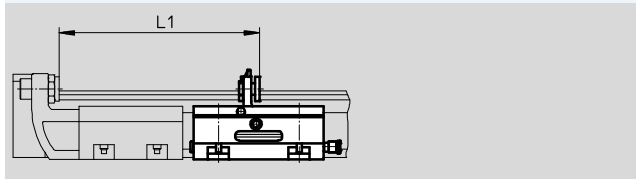

For \varnothing [mm]	L1
25	145.3
32	185.3
40	271.5

between two intermediate positions

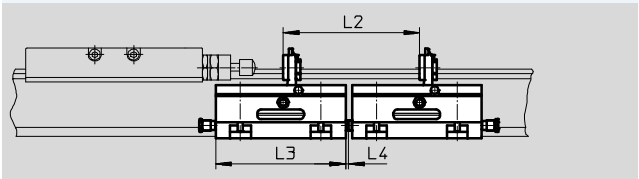

For \varnothing [mm]	L2	L3	L4
25	105	100	2.5
32	105	100	2.5
40	175	170	2.5

- - Note

- Shock absorber not included in scope of delivery. Existing shock absorbers can be removed from the end caps of the linear drive and installed in the shock absorber retainer. Under no circumstances may the

linear drive and the intermediate position module be operated without a shock absorber.

- A shock absorber retainer DADP and a stop KYC are additionally needed when using an intermediate position module.

- The projection (dimension H4) must be noted when using the drive in combination with the intermediate position module DADM. Mounting via foot mountings HP or profile mountings MUC is recommended in this case.

- The position of the stop lever can be detected using proximity sensors SME/SMT-10 → 79.

Linear drives DGC

Accessories

Precision adjustment L



-  - Note

The intermediate position module DADM can be used in both directions. A shock absorber retainer DADP and a stop KYC are additionally needed when using an intermediate position module.

Installation example

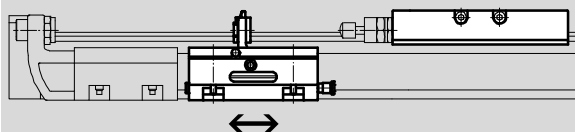

-  - Note

The intermediate position module DADM can be mounted at any position within the stroke.

Technical data

For Ø	[mm]	25	32	40
Pneumatic connection		QS-4		
Operating pressure	[bar]	2.5 ... 8		
Mounting position		Any		
Impact velocity	[m/s]	→ 49		
Swivel time	[ms]	≤100	≤100	≤300
Precision adjustment L	[mm]	2	2	4
Repetition accuracy	[mm]	0.02		
Position sensing		For proximity sensor SME/SMT-10		
Weight	[g]	430	530	970
Ambient temperature	[°C]	-10 ... +60		
Corrosion resistance class CRC ¹⁾		2		
Note on material		Free of copper and PTFE		
		Conforms to RoHS		--

1) Corrosion resistance class 2 to Festo standard 940 070

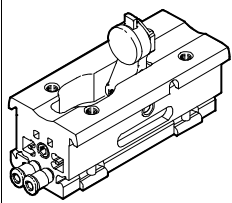

Components subject to moderate corrosion stress. Externally visible parts with primarily decorative surface requirements which are in direct contact with a normal industrial environment or media such as coolants or lubricating agents.

Ordering codes

	For Ø [mm]	Part No.	Type
	25	541700	DADM-DGC-25-A
	32	541701	DADM-DGC-32-A
	40	541702	DADM-DGC-40-A

Linear drives DGC

Accessories

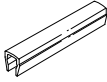
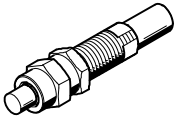
Ordering data						
	For Ø	Remarks	Order code	Part No.	Type	PU ¹⁾
Slot nut NST Technical data → Internet: hmbn						
	25 ... 40	For mounting slot	B	547264	HMBN-5-1M5	10
	50, 63			186566	HMBN-5-2M5	
Centring pin/sleeve ZBS/ZBH Technical data → Internet: zbs, zbh						
	For DGC-G					
	8, 12	For slide	-	150928	ZBS-5	10
	8, 12	For end cap	-	525273	ZBS-2	
	50, 63			150927	ZBH-9	
	For DGC-GF					
	18	For slide	-	150928	ZBS-5	10
	25 ... 63			150927	ZBH-9	
	50, 63	For end cap	-	150927	ZBH-9	
	For DGC-KF					
	8, 12, 18	For slide	-	150928	ZBS-5	10
	25 ... 63			150927	ZBH-9	
	8, 12	For end cap	-	525273	ZBS-2	
18	150928			ZBS-5		
25 ... 63	150927			ZBH-9		
50, 63	150927			ZBH-9		
Slot cover ABP-S Technical data → Internet: abp						
	18 ... 63	For sensor slot each 0.5 m	L	151680	ABP-5-S	2
Shock absorber YSRW Technical data → Internet: ysrw						
	8	For DGC basic version and recirculating ball bearing guide	YSRW	540344	YSRW-DGC-8	1
	12			540345	YSRW-DGC-12	
	18			540346	YSRW-DGC-18-GF	
	25			540348	YSRW-DGC-25-GF	
	32			540350	YSRW-DGC-32-GF	
	40			540352	YSRW-DGC-40-GF	
	50			1232870	YSRW-DGC-40/50-B	
	63	543069		YSRW-DGC-63		
	18	For DGC with recirculating ball bearing guide		540347	YSRW-DGC-18-KF	
	25			540349	YSRW-DGC-25-KF	
	32			540351	YSRW-DGC-32-KF	
	40, 50			1232870	YSRW-DGC-40/50-B	
	63			543069	YSRW-DGC-63	

1) Packaging unit quantity

Linear drives DGC

Accessories

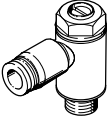

FESTO

Ordering data						
	For Ø	Remarks	Order code	Part No.	Type	PU ¹⁾
One-way flow control valve GRLA			Technical data → Internet: grla			
	8 ... 18	Metal design	-	193137	GRLA-M5-QS-3-D	1
	25, 32			193138	GRLA-M5-QS-4-D	
				193142	GRLA-1/8-QS-3-D	
	40, 50			193143	GRLA-1/8-QS-4-D	
				193144	GRLA-1/8-QS-6-D	
	63			193145	GRLA-1/8-QS-8-D	
				193146	GRLA-1/4-QS-6-D	
	193147			GRLA-1/4-QS-8-D		
	193148			GRLA-1/4-QS-10-D		
	193149			GRLA-3/8-QS-6-D		
193150	GRLA-3/8-QS-8-D					
193151	GRLA-3/8-QS-10-D					

1) Packaging unit quantity

Proximity sensors for piston Ø 8/12 and intermediate position module DADM

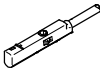
Ordering data – Proximity sensors for C-slot, magneto-resistive						Technical data → Internet: smt	
	Type of mounting	Switch output	Electrical connection, connection direction	Cable length [m]	Part No.	Type	
N/O contact							
	Insertable in the slot from above	PNP	Plug M8x1, 3-pin, in-line	0.3	551375	SMT-10M-PS-24V-E-0,3-L-M8D	
			Cable, 3-wire, in-line	2.5	551373	SMT-10M-PS-24V-E-2,5-L-OE	

Ordering data – Proximity sensors for C-slot, magnetic reed						Technical data → Internet: sme	
	Type of mounting	Switch output	Electrical connection, connection direction	Cable length [m]	Part No.	Type	
N/O contact							
	Insertable in the slot from above	Contacting	Plug M8x1, 3-pin, in-line	0.3	551367	SME-10M-DS-24V-E-0,3-L-M8D	
			Cable, 3-wire, in-line	2.5	551365	SME-10M-DS-24V-E-2,5-L-OE	
			Cable, 2-wire, in-line	2.5	551369	SME-10M-ZS-24V-E-2,5-L-OE	
	Insertable in the slot lengthwise	Contacting	Plug M8x1, 3-pin, in-line	0.3	173212	SME-10-SL-LED-24	
			Cable, 3-wire, in-line	2.5	173210	SME-10-KL-LED-24	

Proximity sensors for piston Ø 18 ... 63

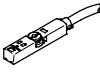
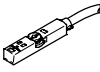
Ordering data – Proximity sensors for T-slot, magneto-resistive						Technical data → Internet: smt	
	Type of mounting	Switch output	Electrical connection	Cable length [m]	Part No.	Type	
N/O contact							
	Insertable in the slot from above, flush with cylinder profile, short design	PNP	Cable, 3-wire	2.5	574335	SMT-8M-A-PS-24V-E-2,5-OE	
			Plug M8x1, 3-pin	0.3	574334	SMT-8M-A-PS-24V-E-0,3-M8D	
			Plug M12x1, 3-pin	0.3	574337	SMT-8M-A-PS-24V-E-0,3-M12	
		NPN	Cable, 3-wire	2.5	574338	SMT-8M-A-NS-24V-E-2,5-OE	
			Plug M8x1, 3-pin	0.3	574339	SMT-8M-A-NS-24V-E-0,3-M8D	
N/C contact							
	Insertable in the slot from above, flush with cylinder profile, short design	PNP	Cable, 3-wire	7.5	574340	SMT-8M-A-PO-24V-E-7,5-OE	



Linear drives DGC

Accessories

FESTO

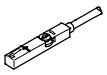
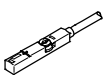
Proximity sensors for piston $\varnothing 18 \dots 63$

Ordering data – Proximity sensors for T-slot, magnetic reed					Technical data → Internet: sme	
	Type of mounting	Switch output	Electrical connection	Cable length [m]	Part No.	Type
N/O contact						
	Insertable in the slot from above, flush with cylinder profile	Contacting	Cable, 3-wire	2.5	543862	SME-8M-DS-24V-K-2,5-OE
				5.0	543863	SME-8M-DS-24V-K-5,0-OE
			Cable, 2-wire	2.5	543872	SME-8M-ZS-24V-K-2,5-OE
			Plug M8x1, 3-pin	0.3	543861	SME-8M-DS-24V-K-0,3-M8D
N/C contact						
	Insertable in the slot from above, flush with cylinder profile	Contacting	Cable, 3-wire	7.5	546799	SME-8M-DO-24V-K-7,5-OE

Ordering data – Connecting cables				Technical data → Internet: nebu	
	Electrical connection, left	Electrical connection, right	Cable length [m]	Part No.	Type
	Straight socket, M8x1, 3-pin	Cable, open end, 3-wire	2.5	541333	NEBU-M8G3-K-2.5-LE3
			5	541334	NEBU-M8G3-K-5-LE3
	Straight socket, M12x1, 5-pin	Cable, open end, 3-wire	2.5	541363	NEBU-M12G5-K-2.5-LE3
			5	541364	NEBU-M12G5-K-5-LE3
	Angled socket, M8x1, 3-pin	Cable, open end, 3-wire	2.5	541338	NEBU-M8W3-K-2.5-LE3
			5	541341	NEBU-M8W3-K-5-LE3
	Angled socket, M12x1, 5-pin	Cable, open end, 3-wire	2.5	541367	NEBU-M12W5-K-2.5-LE3
			5	541370	NEBU-M12W5-K-5-LE3