

Miniature Guide Rod Cylinder



Series MGJ

Actual size (MGJ6-5)

Non-rotating accuracy: $\pm 0.1^\circ$

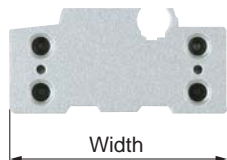

- Mounting from 2 directions

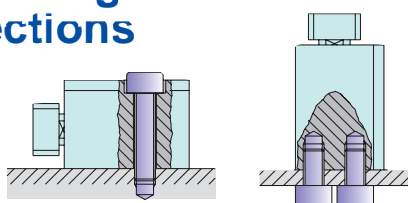

- Two auto switches can be mounted even for 5 mm strokes
- Integral wiring/piping to one direction



Dimensions

Bore size	Overall length	Width	Height
6	23 + Stroke	29	14.5
10	25 + Stroke	33	17

Unit: mm

Weight

Bore size (mm)	Standard stroke (mm)			
	5	10	15	20
6	27.3	33.0	38.4	—
10	40.6	48.0	55.6	63.2

Unit: g

Series Variations

Series	Bore size (mm)	Guide rod size (mm)	Standard stroke (mm)				Cushion	Auto switch
			5	10	15	20		
MGJ	6	5	●	●	●	—	Rubber bumper (Both sides)	D-F8□
	10	6	●	●	●	●		

Miniature Guide Rod Cylinder

Series MGJ

∅6, ∅10

How to Order

Miniature Guide Rod Cylinder

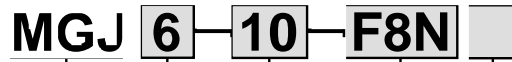

Miniature Guide Rod Cylinder

Bore size

6	6 mm
10	10 mm

Cylinder stroke (mm)
Refer to the following table ① and ②.

Number of auto switches

Nil	2 pcs.
S	1 pc.

Auto switch type

Nil	Without auto switch (built-in magnet cylinder)
-----	--

- * Select the applicable auto switch from the table below.
- * Auto switches shipped together (not assembled).

Table ① Standard strokes

Bore size (mm)	Standard stroke (mm)
6	5, 10, 15
10	5, 10, 15, 20

Table ② Intermediate stroke by the 1 mm stroke

Bore size (mm)	Applicable stroke (mm)
6	1 to 15 (Spacer type)
10	1 to 20 (Spacer type)
Example	Model no.: MGJ6-9 Installing a 1 mm width spacer for MGJ6-10 External size: same as MGJ6-10

* Minimum stroke for auto switch mounting is 4 mm.

Table ③ Applicable auto switches/Refer to page 3 for detailed auto switch specifications.

Type	Special function	Electrical entry	Indicator light	Wiring (output)	Load voltage		Auto switch part no.			Applicable load		
					DC	Direct mounting	Lead wire length (m)					
							0.5 (Nil)	3 (L)	5 (Z)			
Solid state switch	-	Grommet (Perpendicular)	Yes	3-wire (NPN)	24 V	5 V 12 V	F8N	●	●	○	IC circuit	Relay PLC
				3-wire (PNP)			F8P	●	●	○		
				2-wire	12 V	F8B	●	●	○	-		

* Lead wire length symbols: J, S, H, Z
 Nil
 Example) F8N
 Example) F8NL
 Example) F8NZ

- * Auto switches marked with ○ are produced upon receipt of order.
- * When using non-applicable auto switches, please consult with SMC.



⚠ Caution

This product should not be used as a stopper.

Specifications

Bore size (mm)	6	10
Action	Double acting	
Fluid	Air	
Proof pressure	1.05 MPa	
Maximum operating pressure	0.7 MPa	
Minimum operating pressure	0.15 MPa	
Ambient and fluid temperature	-10 to 60°C (with no freezing)	
Cushion	Rubber bumper at both ends	
Lubrication	Non-lube	
Piston speed	50 to 500 mm/s ^{Note)}	
Thread tolerance	JIS class 2	
Stroke length tolerance	+1.0 mm 0	
Port size	M3	
Guide size	ø5	ø6

Note) Within allowable kinetic energy use only

Theoretical Output

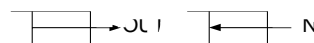

Unit: V

Bore size (mm)	Rod size (mm)	Operating direction	Piston area (mm ²)	Operating pressure (MPa)			
				0.15	0.3	0.5	0.7
6	3	OUT	28.3	4.24	8.48	14.15	19.81
		IN	21.2	3.18	6.36	10.60	14.84
10	5	OUT	78.5	11.77	23.55	39.25	54.95
		IN	58.9	8.83	17.67	29.45	41.23

Weight

Unit: g

Bore size (mm)	Standard stroke (mm)			
	5	10	15	20
6	27.3	33.0	38.4	—
10	40.6	48.0	55.6	63.2

Allowable Rotational Torque of Plate

For the rotational torque (T) added to the plate (rod end), use a value no more than the values in the table. Operation outside of this range may cause excessive impact, which may result in the damage of the devices.

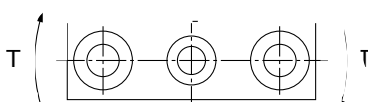

Unit: N·m

Bore size (mm)	Stroke (mm)			
	5	10	15	20
6	0.92	0.73	0.61	—
10	4.75	3.96	3.36	2.87

Plate Non-rotating Accuracy

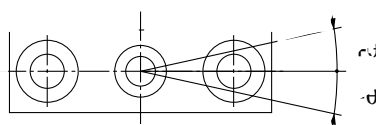

Bore size (mm)	Non-rotating accuracy θ
6	±0.1°
10	

* When extending the cylinder (initial value), non-rotating accuracy θ, without bias and deflection of guide rods, θ should be a value no more than the value in the table as a guide.

Series MGJ

Allowable Kinetic Energy

When driving the cylinder with inertial load, keep kinetic energy no more than the allowable value. The area between bold lines in the below graphic shows the relation between load weight and maximum speed.

Bore size (mm)	6	10
Operating piston speed (m/s)	0.05 to 0.5	
Allowable kinetic energy (J)	0.012	0.035

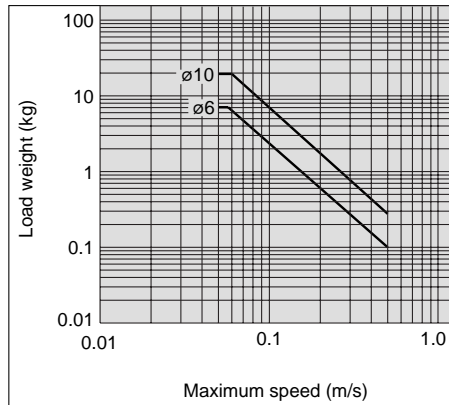
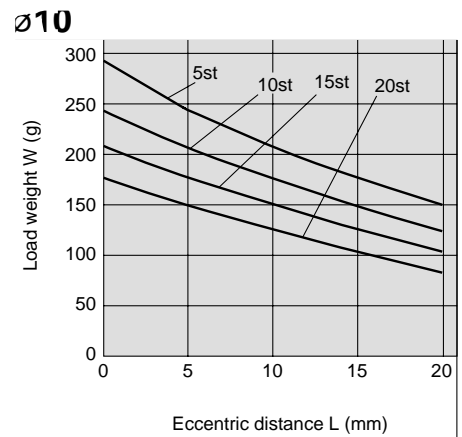
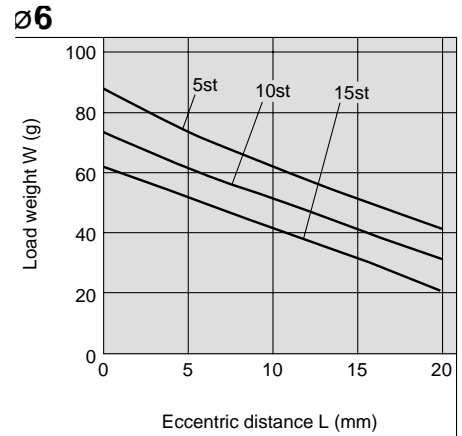
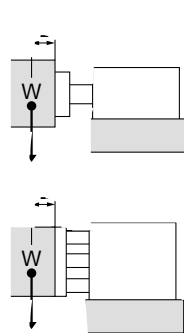
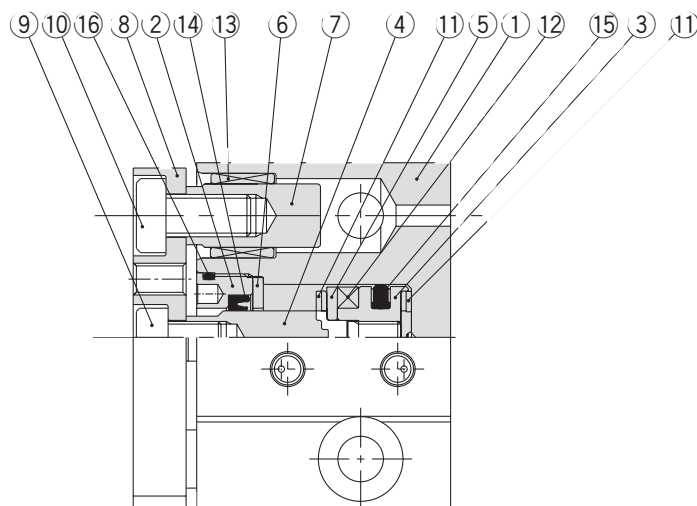

Plate Allowable Lateral Load

When the eccentric distance L , generates from the plate (rod end), be sure to keep the load weight W no more than a value in the below graphic. Operation outside of this range may cause excessive impact, which may result in the damage to the devices.



Construction



Parts list

No.	Description	Material	Note
1	Body	Aluminum alloy	Hard anodized
2	Rod cover	Aluminum alloy	Chromate
3	Piston	Aluminum alloy	Chromate
4	Piston rod	Stainless steel	
5	Magnet retainer	Aluminum alloy Stainless steel	Chromate, n case of 10 n case of 11
6	Seal retainer	Aluminum alloy Stainless steel	Chromate, n case of 16 n case of 11
7	Guide rod	Constructional steel	Hard chromium electroplate
8	Plate	Aluminum alloy	Hard anodized
9	Torque socket head bolt	Constructional steel	Nickel plated, n case of 10
10	Hexagon socket head cap screw	Constructional steel	Nickel plated, n case of 10
11	Brazier head hexagon socket bolt	Constructional steel	Nickel plated
12	Bumper	Resin	
13	Magnet	Magnet	
14	Bushing	Sintered oil-impregnated bearing	
15	Rod seal	NBR	
16	Piston seal	NBR	
17	O-ring	NBR	

Dimensions

ø6

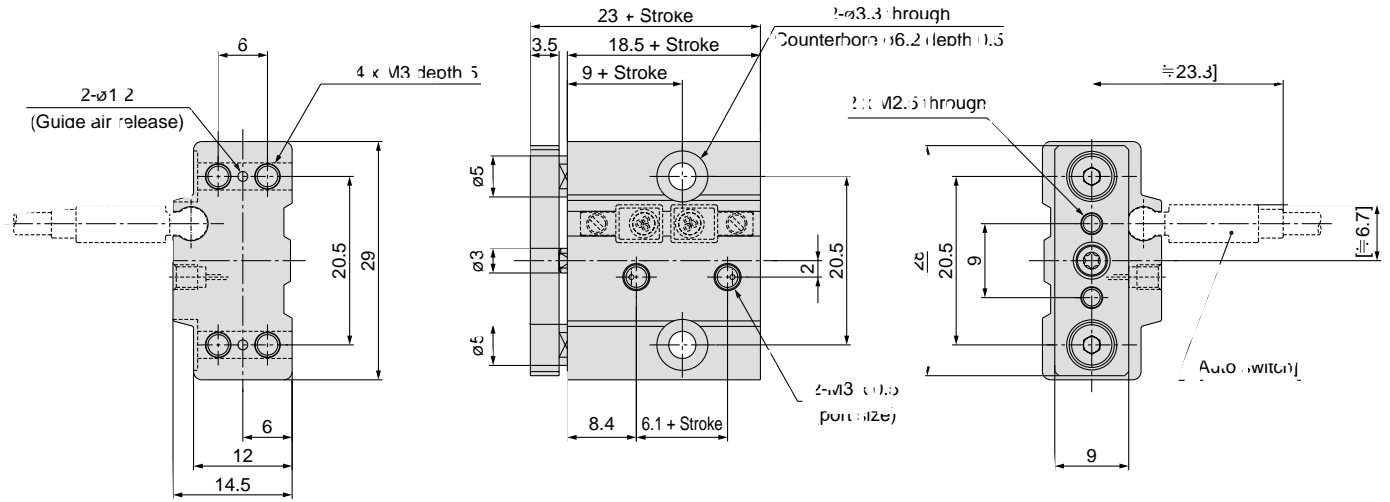

ø10

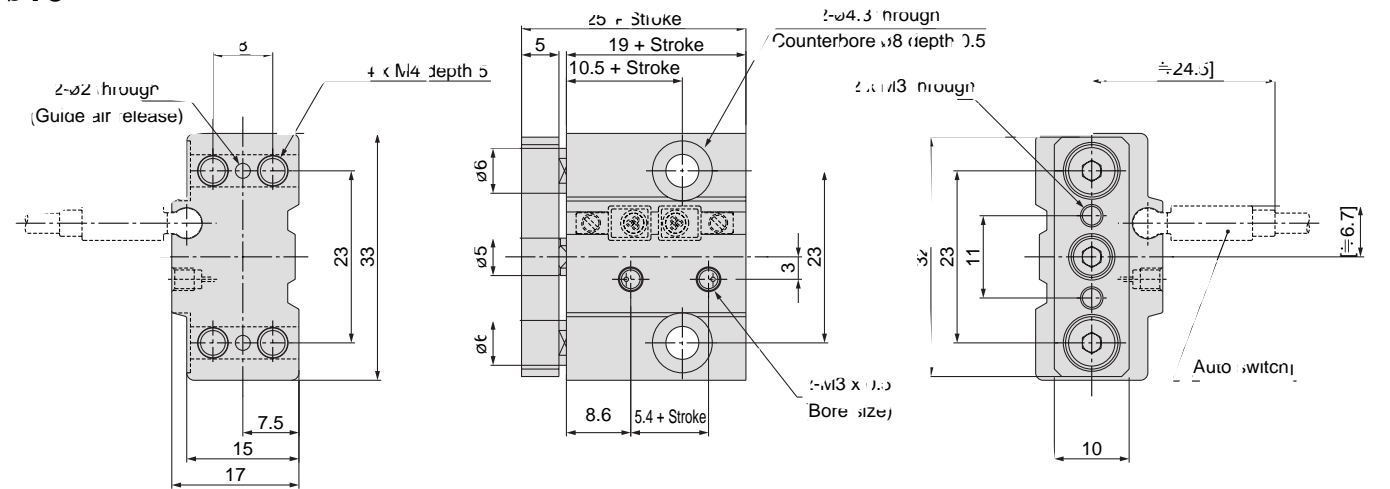

Series MGJ

Auto Switches/Proper Mounting Position for Stroke End Detection

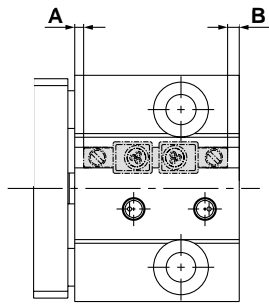

Bore size	A	B	Operating range (mm)
ø6	1.6	0.9	3
ø10	1.3	1.7	4

Auto Switch Mounting

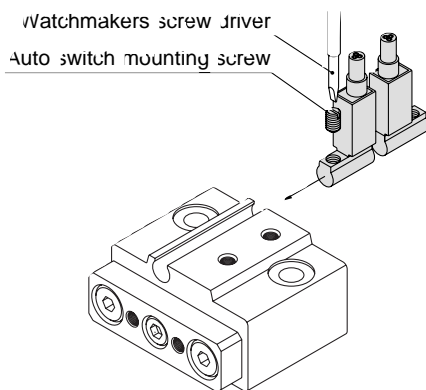

- Use a watchmakers screw driver with a handle about 50-60 mm in diameter when tightening the auto switch mounting screw.
- Tightening torque of auto switch mounting screw should be set 0.11 to 0.20 N·m.

Auto Switch Common Specifications

Auto Switch Common Specifications

Type	Solid state switch
Operating time	1 ms or less
Impact resistance	1000 m/s ²
Insulation resistance	50 MΩ or more at 500 VDC M (between lead wire and case)
Withstand voltage	1000 VAC for 1 minute (between lead wire and case)
Ambient temperature	-10 to 60°C
Enclosure	IEC529 standard IP67, JISC0920 waterproof construction

Lead Wire Length

Lead wire length indication

(Example)

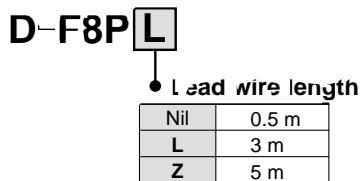

Note 1) Lead wire length Z: 5 m applicable auto switch
Solid state switch: All types are produced upon receipt of order.
Note 2) For solid state with flexible wire specification, add "61" after the lead wire length.

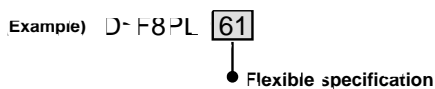

Lead Wire Colour Change

Lead wire colours of SMC switches have been changed for production beginning September 1996 and thereafter. Please refer to the tables provided. Special care should be taken regarding wire polarity during the time that the old colours still coexist with the new colours.

2-wire

	Old	New
Output (+)	Red	Brown
Output (-)	Black	Blue

3-wire

	Old	New
Power supply (+)	Red	Brown
Power supply GND	Black	Blue
Output	White	Black

Series MGJ Auto Switch Connections and Examples

Basic Wiring

Solid state 3-wire, NPN

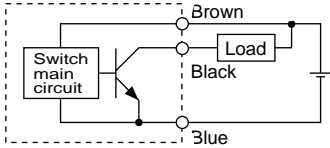

(Power supplies for switch and load are separate.)

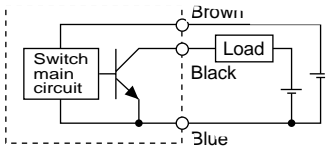

Solid state 3-wire, PNP

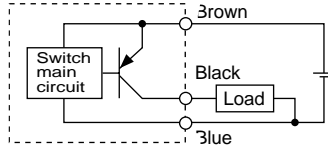

2-wire

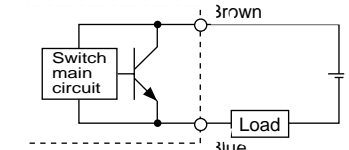
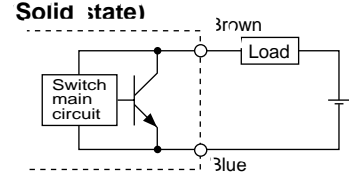

Examples of Connection to PLC (Programable Logic Controller)

• Sink input specifications
3-wire, NPN

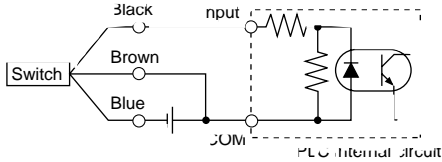

2-wire

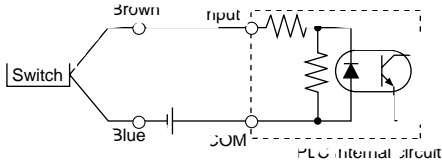

• Source input specifications
3-wire, PNP

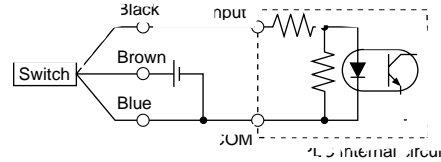

2-wire

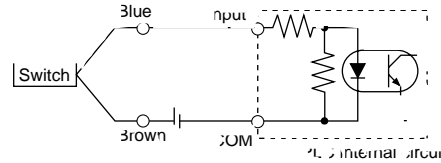

Connect according to the applicable PLC input specifications, as the connection method will vary depending on the PLC input specifications.

Connection Examples for AND (Series) and OR (Parallel)

• 3-wire

AND connection for NPN output (using relays)

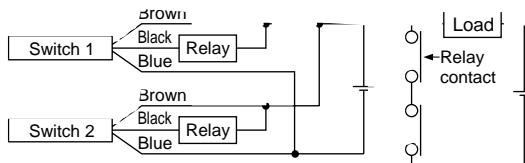

AND connection for NPN output (performed with switches only)

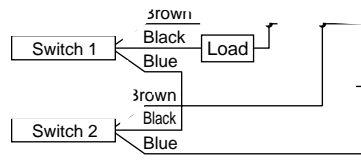

OR connection for NPN output

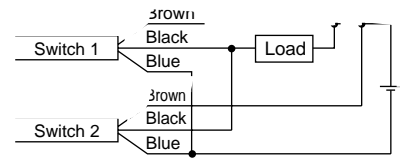

The indicator lights will light up when both switches are turned ON.

2-wire with 2-switch AND connection

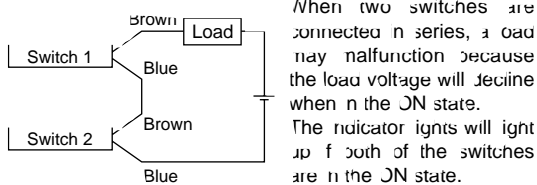

When two switches are connected in series, a load may malfunction because the load voltage will decrease when in the ON state. The indicator lights will light up if both of the switches are in the ON state.

Load voltage at ON Power supply voltage Internal voltage drop < 2 pcs.

24 V + 4 V x 2 pcs.

13 V

Example: Power supply is 24 V/DC.

Internal voltage drop in switches is 4 V.

2-wire with 2-switch OR connection

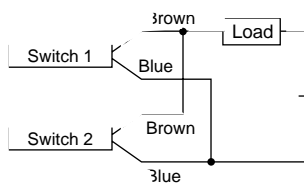

Solid state

When two switches are connected in parallel, malfunction may occur because the load voltage will increase when in the OFF state.

Load voltage at OFF Package current (2 pcs.) Load impedance

11 A (2 pcs.) 3 Ω

5 V

Example: Load impedance is 3 Ω.

Package current from switches is 11 A.

Solid State Switches: Direct Mounting Type D-F8N/D-F8P/D-F8B



Refer to www.smcworld.com for details of products compatible with overseas standards.

Auto Switch Specifications

PLC: Programmable Logic Controller

Auto switch part No.	D-F8N	D-F8P	D-F8B
Electrical entry direction	Perpendicular	Perpendicular	Perpendicular
Wiring type	3-wire		2-wire
Output type	NPN	PNP	—
Applicable load	IC circuit, 24 VDC relay, PLC		24 VDC relay, PLC
Power supply voltage	5, 12, 24 VDC (4.5 to 28 VDC)		—
Current consumption	10 mA or less		—
Load voltage	28 VDC or less	—	24 VDC (10 to 28 VDC)
Load current	40 mA or less	80 mA or less	2.5 to 40 mA
Internal voltage drop	1.5 V or less (0.8 V or less at 10 mA load current)	0.8 V or less	4 V or less
Leakage current	100 μ A or less at 24 VDC		0.8 mA or less at 24 VDC
Indicator light	Red LED lights when ON		

Grommet



Caution

Operating precautions

Fix the switch with appropriate screw installed on the switch body. If using other screws, switch may be damaged.

Lead wires

All lead wires are provided with heavy insulation cable, 2.0 mm ϕ .

D-F8N, D-F8P: 3-core (Brown, Black, Blue Red, White, Black), 3.0 mm ϕ

D-F8B: 2-core (Brown, Blue Red, Black), 3.0 mm ϕ

Note 1) Refer to page 10 for auto switch common specifications.

Note 2) Refer to page 10 for lead wire lengths.

Auto switch internal circuit

D-F8N

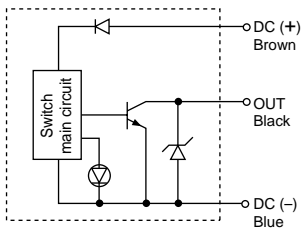

D-F8P

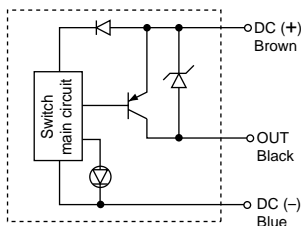

D-F8B

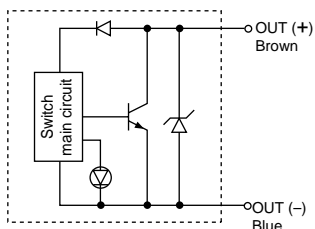

Weight

(unit: g)

Auto switch part No.	D-F8N	D-F8P	D-F8B
Lead wire length (m)	0.5	7	7
	3	32	32
	5	52	52

Dimensions

D-F8N, D-F8P, D-F8B

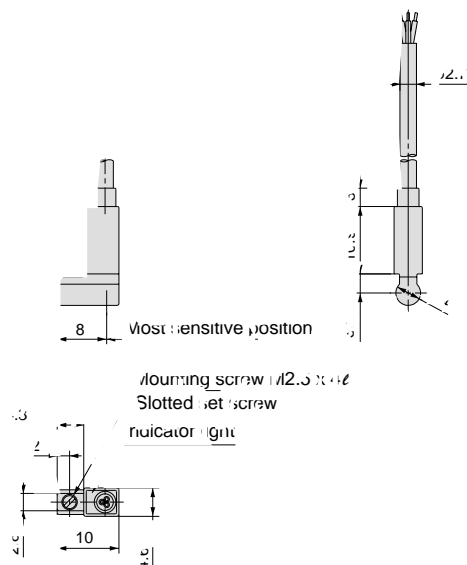



Series MGJ

Safety Instructions

These safety instructions are intended to prevent a hazardous situation and/or equipment damage. These instructions indicate the level of potential hazard by a label of “Caution”, “Warning” or “Danger”. To ensure safety, be sure to observe ISO 4414 ^{Note 1)}, JIS B 8370 ^{Note 2)} and other safety practices.

⚠ Caution : Operator error could result in injury or equipment damage.

⚠ Warning : Operator error could result in serious injury or loss of life.

⚠ Danger : In extreme conditions, there is a possible result of serious injury or loss of life.

Note 1) ISO 4414: Pneumatic fluid power – General rules relating to systems

Note 2) JIS B 8370: Pneumatic System Axiom

⚠ Warning

1. The compatibility of pneumatic equipment is the responsibility of the person who designs the pneumatic system or decides its specifications.

Since the products specified here are used in various operating conditions, their compatibility with the specific pneumatic system must be based on specifications or after analysis and/or tests to meet your specific requirements. The expected performance and safety assurance will be the responsibility of the person who has determined the compatibility of the system. This person should continuously review the suitability of all items specified, referring to the latest catalogue information with a view to giving due consideration to any possibility of equipment failure when configuring a system.

2. Only trained personnel should operate pneumatically operated machinery and equipment.

Compressed air can be dangerous if handled incorrectly. Assembly, handling, or maintenance of pneumatic systems should be performed by trained and experienced operators.

3. Do not service machinery/equipment or attempt to remove components until safety is confirmed.

1. Inspection and maintenance of machinery/equipment should only be performed once measures to prevent falling or runaway of the driven object have been confirmed.
2. When equipment is to be removed, confirm the safety process as mentioned above. Cut the supply pressure for this equipment and exhaust all residual compressed air in the system.
3. Before machinery/equipment is restarted, take measures to prevent shooting-out of cylinder piston rod, etc.

3. Contact SMC if the product is to be used in any of the following conditions:

1. Conditions and environments beyond the given specifications, or if product is used outdoors.
2. Installation on equipment in conjunction with atomic energy, railway, air navigation, vehicles, medical equipment, food and beverages, recreation equipment, emergency stop circuits, clutch and brake circuits in press applications, or safety equipment.
3. An application which has the possibility of having negative effects on people, property, or animals, requiring special safety analysis.



Series MGJ

Actuator Precautions 1

Be sure to read before handling.

Design

Warning

1. There is a possibility of dangerous sudden action by air cylinders if sliding parts of machinery are twisted due to external forces, etc.

In such cases, human injury may occur; e.g., by catching hands or feet in the machinery, or damage to the machinery itself may occur. Therefore, the machine should be adjusted to operate smoothly and designed to avoid such dangers.

2. A protective cover is recommended to minimize the risk of personal injury.

If a stationary object and moving parts of a cylinder are in close proximity, personal injury may occur. Design the structure to avoid contact with the human body.

3. Securely tighten all stationary parts and connected parts so that they will not become loose.

Especially when a cylinder operates with high frequency or is installed where there is a lot of vibration, ensure that all parts remain secure.

4. A deceleration circuit or shock absorber may be required.

When a driven object is operated at high speed or the load is heavy, a cylinder's cushion will not be sufficient to absorb the impact. Install a deceleration circuit to reduce the speed before cushioning, or install an external shock absorber to relieve the impact. In this case, the rigidity of the machinery should also be examined.

5. Consider a possible drop in circuit pressure due to a power outage, etc.

When a cylinder is used in a clamping mechanism, there is a danger of work pieces dropping if there is a decrease in clamping force due to a drop in circuit pressure caused by a power outage, etc. Therefore, safety equipment should be installed to prevent damage to machinery and human injury. Suspension mechanisms and lifting devices also require consideration for drop prevention.

6. Consider a possible loss of power source.

Measures should be taken to protect against bodily injury and equipment damage in the event that there is a loss of power to equipment controlled by pneumatics, electricity, or hydraulics.

7. Design circuitry to prevent sudden lurching of driven objects.

When a cylinder is driven by an exhaust centre type directional control valve or when starting up after residual pressure is exhausted from the circuit, etc., the piston and its driven object will lurch at high speed if pressure is applied to one side of the cylinder because of the absence of air pressure inside the cylinder. Therefore, equipment should be selected and circuits designed to prevent sudden lurching, because there is a danger of human injury and/or damage to equipment when this occurs.

8. Consider emergency stops.

Design so that human injury and/or damage to machinery and equipment will not be caused when machinery is stopped by a safety device under abnormal conditions, a power outage or a manual emergency stop.

9. Consider the action when operation is restarted after an emergency stop or abnormal stop.

Design the machinery so that human injury or equipment damage will not occur upon restart of operation. When the cylinder has to be reset at the starting position, install safe manual control equipment.

Selection

Warning

1. Check the specifications.

The products featured in this catalogue are designed for use in industrial compressed air systems. If the products are used in conditions where pressure and/or temperature are outside the range of specifications, damage and/or malfunctions may occur. Do not use in these conditions. (Refer to specifications.) Consult with SMC if you use a fluid other than compressed air.

2. Intermediate stops

When intermediate stopping of a cylinder piston is performed with a 3-position closed center type directional control valve, it is difficult to achieve stopping positions as accurately and precisely as with hydraulic pressure due to the compressibility of air.

Furthermore, since valves and cylinders are not guaranteed for zero air leakage, it may not be possible to hold a stopped position for an extended period of time. Contact SMC in case it is necessary to hold a stopped position for an extended period.

Caution

1. Operate the piston in such a way that collision damage will not occur at the stroke end.

The operation range should prevent damage from occurring when a piston, having inertial force, stops by striking the cover at the stroke end. Refer to the cylinder model selection procedure for the maximum usable stroke.

2. Use a speed controller to adjust the cylinder drive speed, gradually increasing from a low speed to the desired speed setting.

Mounting

Caution

1. Be sure to connect so that the rod axis is aligned with the load and movement direction.

If they are not aligned, stress could be applied to the rod and the tube, causing the inner surface of the tube, the bushing, the rod surface, and the seals to wear and to become damaged.

2. When using an external guide, connect the rod end and the load in such a way that there is no interference at any positions within the stroke.

3. Do not scratch or gouge the sliding parts of the cylinder tube or piston rod by striking or grasping them with other objects.

Cylinder bores are manufactured to precise tolerances, so that even a slight deformation may cause malfunction.

Also, scratches or gouges in the piston rod may lead to damaged seals and cause air leakage.

Scratches or dent on the sliding parts of guide rods may lead to damaged bearing and can cause decreased non-rotating accuracy and malfunction.

4. Do not use until you can verify that equipment can operate properly.

After mounting, repairs, or modification, etc., connect the air supply and electric power, and then confirm proper mounting by means of appropriate function and leak tests.

5. Instruction manual

The product should be mounted and operated after the instruction manual is thoroughly read and its contents are understood.

Keep the instruction manual where it can be referred to as needed.



Series MGJ

Actuator Precautions 1

Be sure to read before handling.

Piping

Caution

1. Preparation before piping

Before piping is connected, it should be thoroughly blown out with air (flushing) or washed to remove chips, cutting oil and other debris from inside the pipe.

2. Wrapping of sealant tape

When screwing together pipes and fittings, be certain that chips from the pipe threads and sealing material do not get inside the piping.

Also, when sealant tape is used, leave 1.5 to 2 thread ridges exposed at the end of the pipe.

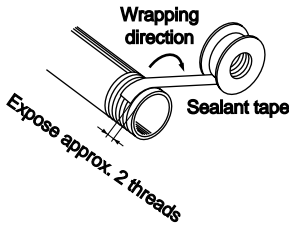

Lubrication

Caution

1. Lubrication of non-lube type cylinder.

The cylinder is lubricated for life at the factory and can be used without any further lubrication.

However, in the event that additional cylinder lubrication is required, be sure to use polyalphaolefin oil or equivalent oil.

Stopping lubrication later may lead to malfunctions because the new lubricant will cancel out the original lubricant. Therefore, lubrication must be continued once it has been started.

Air Supply

Warning

1. Use clean air.

Do not use compressed air that includes chemicals, synthetic oils containing organic solvents, salt or corrosive gases, etc., as it can cause damage or malfunction.

Air Supply

Caution

1. Install air filters

Install air filters at the upstream side of valves. The filtration degree should be 5 µm or finer.

2. Install an after cooler, air dryer, or water separator (Drain Catch).

Air that includes much drainage can cause malfunction of valves and other pneumatic equipment. To prevent this, install an after-cooler, air dryer or water separator, etc.

3. Use the product within the specified range of fluid and ambient temperature.

Take measures to prevent freezing when below 5°C, since moisture in circuits can freeze and cause damage to seals and lead to malfunctions.

Refer to SMC's "Best Pneumatics vol. 4" catalogue for further details on compressed air quality.

Operating Environment

Warning

1. Do not use in environments where there is a danger of corrosion.

Refer to the construction regarding cylinder materials.

2. In dusty locations or where water or oil, splash on the equipment, take suitable measures to protect the rod.

3. When using auto switches, do not operate in an environment with strong magnetic fields.

Maintenance

Warning

1. Perform maintenance inspection and service according to the procedures indicated in the instruction manual.

If handled improperly, malfunction and damage of machinery or equipment may occur.

2. Removal of components, and supply/exhaust of compressed air

Before any machinery or equipment is removed, first ensure that the appropriate measures are in place to prevent the fall or erratic movement of driven objects and equipment, then cut off the electric power and reduce the pressure in the system to zero. Only then should you proceed with the removal of any machinery and equipment.

When machinery is restarted, proceed with caution after confirming that appropriate measures are in place to prevent cylinders from sudden movement.

Caution

1. Drain flushing

Remove drainage from air filters regularly.



Series MGJ

Auto Switch Precautions 1

Be sure to read before handling.

Design and Selection

Warning

1. Check the specifications.

Read the specifications carefully and use this product appropriately. The product may be damaged or malfunction if it is used outside the range of specifications of current current, voltage, temperature or impact.

2. Take precautions when multiple cylinders are used close together.

When two or more auto switch cylinders are lined up in close proximity to each other, magnetic field interference may cause the switches to malfunction. Maintain a minimum cylinder separation of 40 mm. (When the allowable interval is specified for each cylinder series, use the indicated value.)

3. Pay attention to the length of time that a switch is ON at an intermediate stroke position.

When an auto switch is placed at an intermediate position of the stroke and a load is driven at the time the piston passes, the auto switch will operate, but if the speed is too great, the operating time will be shortened and the load may not operate properly. The maximum detectable piston speed is:

$$V \text{ (mm/s)} = \frac{\text{Auto switch operating range (mm)}}{\text{Load operating time (ms)}} \times 1000$$

4. Keep wiring as short as possible.

<Solid state switches>

1) Although wire length should not affect switch function, use a wire that is 100 m or shorter.

5. Take precautions for the internal voltage drop of the switch.

<Solid state switches>

1) Generally, the internal voltage drop will be greater with a 2-wire solid state auto switch than with a reed switch.

• If auto switches are connected in series as shown below, take note that there will be a large voltage drop because of internal resistance in the light emitting diodes. (Refer to internal voltage drop in the auto switch specifications.)

[The voltage drop will be “n” times larger when “n” auto switches are connected.]

Even though an auto switch operates normally, the load may not operate.

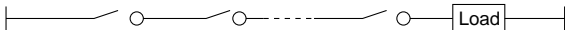

• Similarly, when operating below a specified voltage, it is possible that the load may be ineffective even though the auto switch function is normal. Therefore, the formula below should be satisfied after confirming the minimum operating voltage of the load.

$$\text{Supply voltage} - \text{Internal voltage drop of switch} > \text{Minimum operating voltage of load}$$

Also, note that a 12 VDC relay is not applicable.

6. Pay attention to leakage current.

<Solid state switches>

With a 2-wire solid state auto switch, current (leakage current) flows to the load to operate the internal circuit even when in the OFF state.

$$\text{Current to operate load (OFF condition)} > \text{Leakage current}$$

If the condition given in the above formula is not met, it will not reset correctly (stays on). Use a 3-wire switch if this specification cannot be satisfied.

Moreover, leakage current flow to the load will be “n” times larger when “n” auto switches are connected in parallel.

7. Do not use a load that generates surge voltage.

<Solid state switches>

Although a zener diode for surge protection is connected at the output side of a solid state auto switch, damage may still occur if the surge is applied repeatedly. When a load, such as a relay or solenoid, which generates surge is directly driven, use a type of switch with a built-in surge absorbing element.

8. Cautions for use in an interlock circuit

When an auto switch is used for an interlock signal requiring high reliability, devise a double interlock system to avoid trouble by providing a mechanical protection function, or by also using another switch (sensor) together with the auto switch.

Also perform periodic maintenance inspections and confirm proper operation.

9. Ensure sufficient clearance for maintenance activities.

When designing an application, be sure to allow sufficient clearance for maintenance and inspections.



Series MGJ

Auto Switch Precautions 2

Be sure to read before handling.

Mounting and Adjustment

Warning

1. Do not drop or bump.

Do not drop, bump or apply excessive impacts (1000 m/s² or more for solid state switches) while handling. Although the body of the switch may not be damaged, the inside of the switch could be damaged and cause a malfunction.

2. Do not carry a cylinder by the auto switch lead wires.

Never carry a cylinder by its lead wires. This may not only cause broken lead wires, but it may cause internal elements of the switch to be damaged by the stress.

3. Mount switches using the proper tightening torque.

When a switch is tightened beyond the range of fastening torque, the mounting screws or switch may be damaged. On the other hand, tightening below torque range may allow the switch to slip out of position. (Refer to page 5 for switch mounting, movement and tightening torque, etc.)

Wiring

Warning

1. Avoid repeatedly bending or stretching lead wires.

Broken lead wires will result from repeatedly applying bending stress or stretching force to the lead wires.

2. Be sure to connect the load before power is applied.

<2-wire type>

If the power is turned on when an auto switch is not connected to a load, the switch will be instantly damaged because of excess current.

3. Confirm proper insulation of wiring.

Be certain that there is no faulty wiring insulation (contact with other circuits, ground fault, improper insulation between terminals, etc.). Damage may occur due to excess current flow into a switch.

4. Do not wire with power lines or high voltage lines.

Wire separately from power lines or high voltage lines, avoiding parallel wiring or wiring in the same conduit with these lines. Control circuits including auto switches may malfunction due to noise from these other lines.

Wiring

Warning

5. Do not allow short circuiting of loads.

<Solid state switches>

All models of PNP output type switches do not have built-in short circuit protection circuits. If loads are short circuited, the switches will be instantly damaged, as in the case of reed switches.

Take special care to avoid reverse wiring with the brown [red] power supply line and the black [white] output line on 3-wire type switches.

6. Avoid incorrect wiring.

<Solid state switches>

1) Even if connections are reversed on a 2-wire type switch, the switch will not be damaged because it is protected by a protection circuit, but it will remain in a normally ON state. But reverse wiring in a load short circuit condition should be avoided to protect the switch from being damaged.

2) Even if power supply line (+) and power supply line (-) power supply line connections are reversed on a 3-wire type switch, the switch will be protected by a protection circuit. However, if the power supply line (+) is connected to the blue [black] wire and the power supply line (-) is connected to the black [white] wire, the switch will be damaged.

*** Lead wire colour changes**

Lead wire colours of SMC switches have been changed in order to meet NECA Standard 0402 for production beginning September, 1996 and thereafter. Please refer to the tables provided. Special care should be taken regarding wire polarity during the time that the old colours still coexist with the new colours.

2-wire

	Old	New
Output (+)	Red	Brown
Output (-)	Black	Blue

3-wire

	Old	New
Power supply	Red	Brown
GND	Black	Blue
Output	White	Black

Solid state with diagnostic output

	Old	New
Power supply	Red	Brown
GND	Black	Blue
Output	White	Black
Diagnostic output	Yellow	Orange

Solid state with latch type diagnostic output

	Old	New
Power supply	Red	Brown
GND	Black	Blue
Output	White	Black
Latch type diagnostic output	Yellow	Orange



Series MGJ

Auto Switch Precautions 3

Be sure to read before handling.

Operating Environment

⚠ Warning

1. Never use in the presence of explosive gases.

The construction of our auto switches does not make them explosion-proof. Never use them in the presence of an explosive gas, as this may cause a serious explosion.

2. Do not use in an area where a magnetic field is generated.

Auto switches will malfunction or magnets inside cylinders will become demagnetized. (Consult with SMC regarding the availability of a magnetic field resistant auto switch.)

3. Do not use in an environment where the auto switch will be continually exposed to water.

Switches satisfy IEC standard IP67 construction (JIS C0920: watertight construction). Nevertheless, they should not be used in applications where they are continually exposed to water splash or spray. This may cause deterioration of the insulation or swelling of the potting resin inside switches and may lead to a malfunction.

4. Do not use in an environment with oil or chemicals.

Consult with SMC if auto switches will be used in an environment with coolants, cleaning solvents, various oils or chemicals. If auto switches are used under these conditions for even a short time, they may be adversely affected by improper insulation, a malfunction due to swelling of the potting resin, or hardening of the lead wires.

5. Do not use in an environment with temperature cycles

Consult with SMC if switches are to be used where there are temperature cycles other than normal temperature changes, as they may be adversely affected internally.

6. Do not use in an area where surges are generated.

<Solid state switches>

When there are units (solenoid type lifters, high frequency induction furnaces, motors, etc.) which generate a large amount of surge in the area around cylinders with solid state auto switches, this may cause deterioration or damage to the switches. Avoid sources of surge generation and crossed lines.

7. Avoid accumulation of iron debris or close contact with magnetic substances.

When a large amount of ferrous waste such as machining chips or welding spatter is accumulated, or a magnetic substance (something attracted by a magnet) is brought into close proximity with an auto switch cylinder, it may cause the auto switch to malfunction due to a loss of the magnetic force inside the cylinder.

Maintenance

⚠ Warning

1. Perform the following maintenance periodically in order to prevent possible danger due to unexpected auto switch malfunction.

- 1) Securely tighten switch mounting screws.
If screws become loose or the mounting position is dislocated, retighten screws securely after readjusting the mounting position.
- 2) Confirm that there is no damage to lead wires.
To prevent faulty insulation, replace switches or repair lead wires if damage is discovered.

Other

⚠ Warning

1. Consult SMC concerning water resistance, elasticity of lead wires, and use at welding sites, etc.

Series MGJ

Specific Product Precautions



Be sure to read before handling.

Mounting

Warning

1. Do not put hands or fingers, etc. between the plate and body.

Care should be taken that hands or fingers do not get caught in between the cylinder body and the plate when air pressure is applied.

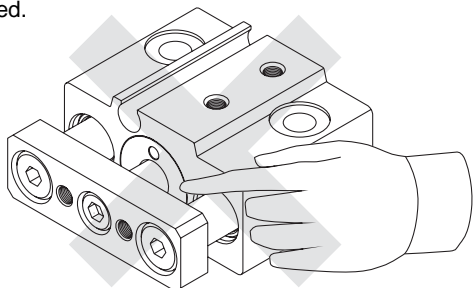

Caution

2. Do not scratch or dent the sliding parts of the piston rod and guide rods.

Damage to seals can cause air leakage or malfunction, etc.

3. When mounting the Miniature Guide Rod Cylinder, be sure to use proper tightening torque for tightening screws.

Model	Bolt	Proper tightening torque (N · m)	
		Top mounting	Bottom mounting
MGJ6	M3 x 0.5	1.2	0.3
MGJ10	M4 x 0.7	2.7	0.7

Top mounting

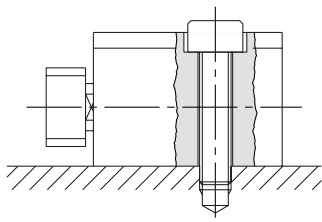

Bottom mounting

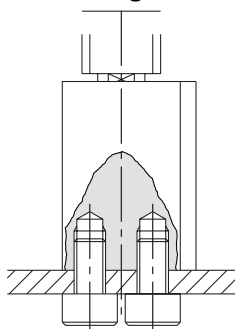

Mounting

Caution

4. Flatness of mounting surface should be less than 0.02 mm.

When mounting Miniature Guide Rod Cylinder, or mounting plate to work piece, sideling mounting surface may cause malfunction.

5. Be sure that the piston rod is extended before mounting loads.

If loads are mounted to the plate when the piston rods are retracted, it can lead to distortion of the guides resulting in malfunction.

6. When mounting loads, be sure to use proper tightening torque for tightening screws.

Model	Bolt	Proper tightening torque (N · m)
MGJ6	M2.5 x 0.45	0.5
MGJ10	M3 x 0.5	1.0

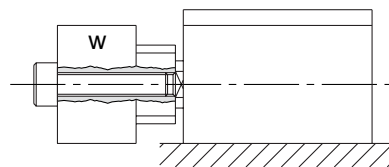

Others

Caution

1. This product should not be used as a stopper.

SMC CORPORATION (Europe)

Austria	☎ +43 226262280	www.smc.at	sales@smc.at
Belgium	☎ +32 33551464	www.smc-pneumatics.be	post@smcpneumatics.be
Bulgaria	☎ +359 2 9744492	www.smc.bg	sales@smc.at
Czech Republic	☎ +42 0541424611	www.smc.cz	office@smc.cz
Denmark	☎ +45 70252900	www.smc-pneumatik.dk	smc@smc-pneumatik.dk
Estonia	☎ +372 6593540	www.smc-pneumatics.ee	smc@smcpneumatics.ee
Finland	☎ +358 9859580	www.smc.fi	smc@smc.fi
France	☎ +33 164761000	www.smc-france.fr	contact@smc-france.fr
Germany	☎ +49 61034020	www.smc-pneumatik.de	info@smc-pneumatik.de
Greece	☎ +30 2103426076	www.smceu.com	parianos@hol.gr
Hungary	☎ +36 13711343	www.smc-automation.hu	office@smc-automation.hu
Ireland	☎ +353 14039000	www.smc-pneumatics.ie	sales@smcpneumatics.ie
Italy	☎ +39 0292711	www.smcitalia.it	mailbox@smcitalia.it
Latvia	☎ +37 7779474	www.smc.lv	info@smclv.lv

Netherlands	☎ +31 205318888	www.smc-pneumatics.nl	info@smcpneumatics.nl
Norway	☎ +47 67129020	www.smc-norge.no	post@smc-norge.no
Poland	☎ +48 225485085	www.smc.pl	office@smc.pl
Portugal	☎ +351 226108922	www.smces.es	postpt@smc.smces.es
Romania	☎ +40 213205111	www.smcromania.ro	smcromania@smcromania.ro
Russia	☎ +812 1185445	www.smc-pneumatik.ru	smcfa@peterlink.ru
Slovakia	☎ +421 244456725	www.smc.sk	office@smc.sk
Slovenia	☎ +386(7)3885249	www.smc-ind-avtom.si	office@smc-ind-avtom.si
Spain	☎ +34 945184100	www.smces.es	post@smc.smces.es
Sweden	☎ +46 86030700	www.smc.nu	post@smcpneumatics.se
Switzerland	☎ +41 523963131	www.smc.ch	info@smc.ch
Turkey	☎ +90 2122211516	www.entek.com.tr	smc-entek@entek.com.tr
UK	☎ +44 8001382930	www.smc-pneumatics.co.uk	sales@smcpneumatics.co.uk

European Marketing Centre ☎ +34 945184100
SMC CORPORATION ☎ +81 0335022740

www.smceu.com
www.smcworld.com