

NSK

Miniature PU Series/PE Series

NSK Miniature Linear Guides, ideal for semiconductor manufacturing and medical equipment



Smooth motion and unprecedented lightness The advanced NSK Miniature Linear Guides

The new generation PU series/PE series inherit the outstanding lineage of the NSK miniature linear guides LU series/LE series. Improve dynamic friction characteristics and create smoother motion with reduced noise intensity. The new design supports a wide variety of applications.

Miniature PU Series/PE Series

1 Features

1. Motion performance

Highly smooth operation is achieved by smooth ball recirculation.

2. Lightweight

The ball slide is fabricated to be approximately 20% lighter than conventional models* by the application of resin to a part of its body.
* Miniature LU series/LE series

3. Reduced noise intensity

Resin components applied in the ball circulating system reduce collision noise between steel balls and the inner wall of circulating circuits.

4. Low dust generation

The new design generates less dust compared to conventional models.

5. Excellent dust resistance

Compact space between the side of the rails and the inner walls of the ball slide prevents the entrance of foreign matter.

6. High corrosion resistance

High corrosion-resistant martensite stainless steel is incorporated as a standard feature provides excellent resistance to corrosion.

7. Easy to handle

Safety design prevents steel balls from dropping out of the ball slide even when the slide is removed from the rail.

8. Long-term maintenance-free

Equipped with NSK K1™ Lubrication unit realizes long-term, maintenance-free use.

9. Fast delivery

Lineup of random-matching rails and ball slides in the series facilitates fast delivery.

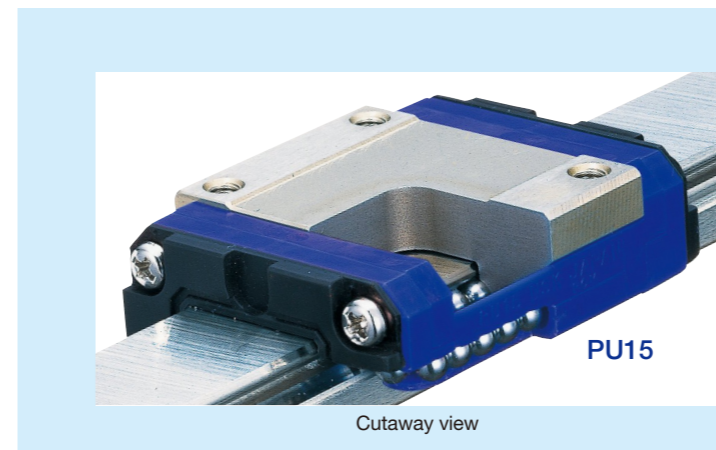
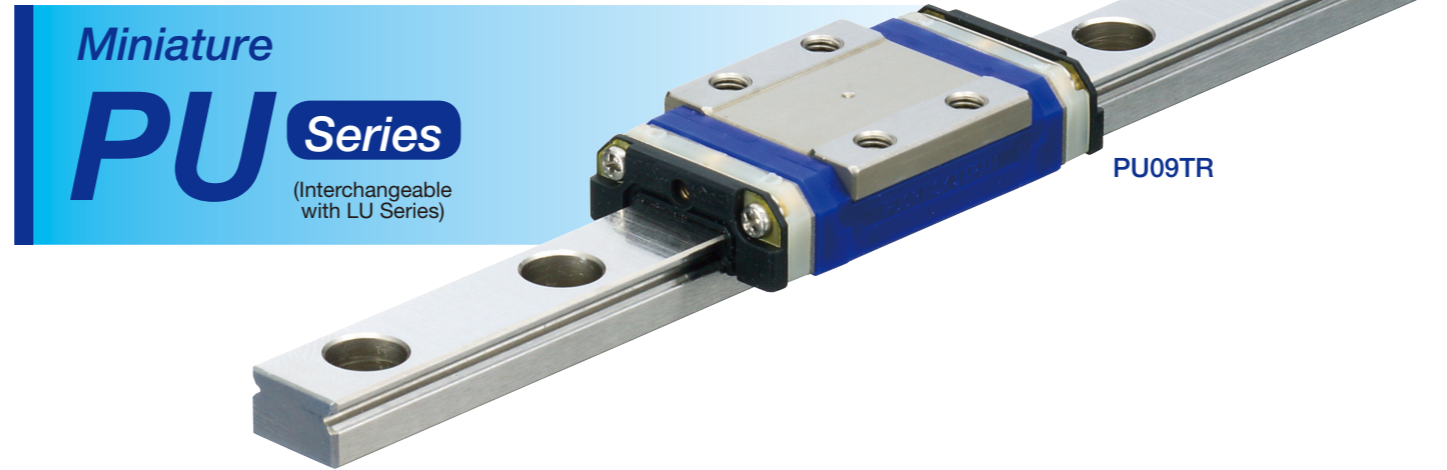

Smoother motion

The resin ball recirculation component creates an optimal configuration, resulting in smoother motion.

Test conditions: Oil lubrication (VG68)
Operating speed: 1 000 mm/min
Load cell rated capacity: 5N

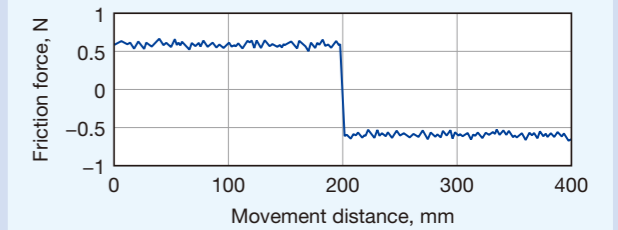

Fig. 1-1 Fluctuations in dynamic friction

Low dust generation

The PU series/PE series, with resin ball recirculation components, generates less dust than a conventional ball recirculation system that goes right through the ball slide.

Test conditions: Grease lubrication (LG2)
Operating speed: 600 mm/min
Stroke: 200 mm

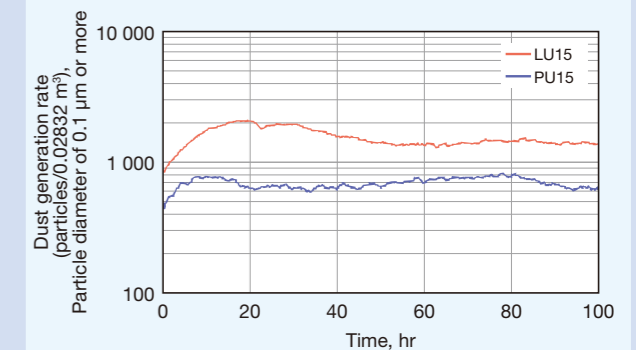

Fig. 1-2 Dust generation rate

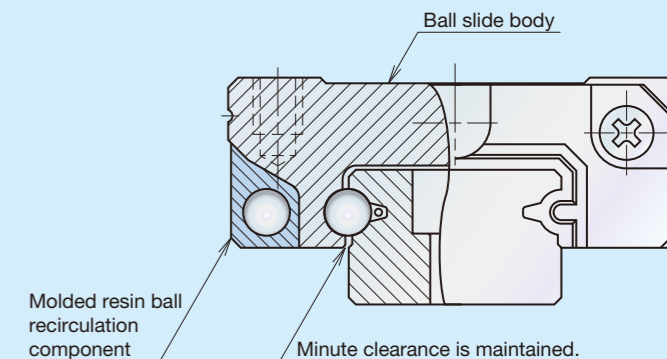

Fig. 2 Cross sectional front view

Developed for precision positioning tables, supporting cutting-edge equipment, including semiconductor manufacturing and medical devices

2 Reference number

Reference numbers will be used as reference before finalizing all specifications. Please specify the reference number, except design serial number, to identify the product when ordering, requesting estimates, or inquiring about specifications from NSK.

2.1 Preloaded assembly type

Example: PU 15 0470 AL K 2 - P5 1**

Series name: PU
 Size: 15
 Rail length (mm): 0470
 Ball slide shape code: AL
 Material/surface treatment code: K: Stainless steel, H: Stainless steel + surface treatment
 Accuracy code: P5
 Preload code: 0: Fine clearance (Z0), 1: Slight preload (Z1)
 Design serial number: 2
 Number of ball slides per rail: 1

2.2 Random-matching type

(1) Reference number for rail and ball slide assembly

Example: PU 15 0470 AL K 2 - PC T**

Series name: PU
 Size: 15
 Rail length (mm): 0470
 Ball slide shape code: AL
 Material/surface treatment code: K: Stainless steel, H: Stainless steel + surface treatment
 Accuracy code: PC
 Preload code: T: Fine clearance (ZT)
 Design serial number: 2
 Number of ball slides per rail: 1

(2) Reference number for ball slide of random-matching type

Example: PAU 15 AL S - K

Random-matching ball slide series code: PAU
 PAU: PU Series random-matching ball slide, PAE: PE Series random-matching ball slide
 Size: 15
 Ball slide shape code: AL
 Option code: -K: Equipped with NSK K1
 Material code: S: Stainless steel

(3) Reference number for rail of random-matching type

Example: P1U 15 0470 R K N - PC T**

Random-matching rail series code: P1U
 P1U: PU Series random-matching rail, P1E: PE Series random-matching rail
 Size: 15
 Rail length (mm): 0470
 Rail shape code: R
 S: PU09-12, R: PU05-15 PE05-07-09-12, P: PE15
 Accuracy code: PC
 Preload code: T: Fine clearance (ZT)
 Design serial number: 2
 Butting specification: (*) N: non-butting rails, L: Butting specification
 Material/surface treatment: K: Stainless steel, H: Stainless steel + surface treatment

(*) Please consult NSK for butting rail specification.

3 Accuracy standard

We offer the following accuracy grades: Super precision grade P4, High precision grade P5, Precision grade P6, and Normal grade PN for preloaded assembly type, and Normal grade PC for random-matching type.

Table 1 Tolerance of preloaded assembly

Characteristics	Accuracy grade			
	Super precision P4	High precision P5	Precision grade P6	Normal grade PN
Mounting height H	±10	±15	±20	±40
Variation of H (All ball slides on a set of rails)	5	7	15	25
Mounting width W_2 or W_3	±15	±20	±30	±50
Variation of W_2 or W_3 (All ball slides on reference rail)	7	10	20	20
Running parallelism of surface C to surface A	Shown in Table 3, Fig. 3, Fig. 4			
Running parallelism of surface D to surface B				

Table 3 Running parallelism of ball slide

Rail length (mm)	Preloaded assembly type				Random-matching type	
	Accuracy grade over	Accuracy grade or less	P4	P5	P6	PN
50	2	2	4.5	6	6	6
50 - 80	2	3	5	6	6	6
80 - 125	2	3.5	5.5	6.5	6.5	6.5
125 - 200	2	4	6	7	7	7
200 - 250	2.5	5	7	8	8	8
250 - 315	2.5	5	8	9	9	9
315 - 400	3	6	9	11	11	11
400 - 500	3	6	10	12	12	12
500 - 630	3.5	7	12	14	14	14
630 - 800	4.5	8	14	16	16	16
800 - 1 000	5	9	16	18	18	18
1 000 - 1 250	6	10	17	20	20	20

Table 2 Tolerance of random-matching type: Normal grade PC

Characteristics	Accuracy grade	Normal grade
	PC	PC
Mounting height H	±20	±20
Variation of mounting height H	15①	30②
Mounting width W_2 or W_3	±20	±20
Variation of mounting width W_2 or W_3	20	20
Running parallelism of surface C to surface A	Shown in Table 3, Fig. 3, Fig. 4	
Running parallelism of surface D to surface B		

①Variation on the same rail
 ②Variation on multiple rails

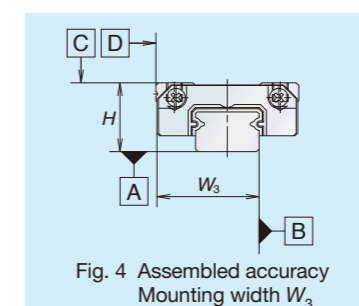
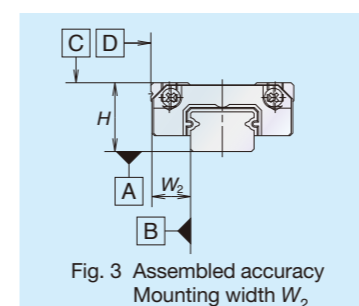

4 Preload and rigidity

We offer three levels of preload: Slight preload (Z1) and Fine clearance (Z0) for preloaded assembly types, along with random-matching types of Fine clearance (ZT). Values for preload and rigidity of the preloaded assembly types are shown in Tables 4 and 5.

Table 4 Preload and rigidity of preloaded assembly of PU series

	Model No.	Preload (N)		Rigidity (N / μ m)	
		Slight preload (Z1)	Slight preload (Z1)	Slight preload (Z1)	Slight preload (Z1)
Standard type	PU05TR	0 - 3		17	
	PU07AR	0 - 8		22	
	PU09TR	0 - 10		30	
	PU12TR	0 - 17		33	
	PU15AL	0 - 33		45	
High-load type	PU09UR	0 - 14		46	
	PU12UR	0 - 25		52	
	PU15BL	0 - 51		75	

Table 5 Preload and rigidity of preloaded assembly of PE series

	Model No.	Preload (N)		Rigidity (N / μ m)	
		Slight preload (Z1)	Slight preload (Z1)	Slight preload (Z1)	Slight preload (Z1)
Standard type	PE05AR	0 - 28		45	
	PE07TR	0 - 29		46	
	PE09TR	0 - 37		61	
	PE12AR	0 - 40		63	
	PE15AR	0 - 49		66	
High-load type	PE09UR	0 - 54		86	
	PE12BR	0 - 59		97	
	PE15BR	0 - 75		114	

Clearance of fine clearance Z0 is 0-3 μ m. Therefore, preload is zero. Clearance values of the random-matching types are shown in Tables 6 and 7.

Table 6 Clearance of random-matching type of PU series Unit: μ m

	Model No.	Fine clearance ZT
Standard type	PU09TR	3 or less
	PU12TR	
	PU15AL	
High-load type	PU09UR	5 or less
	PU12UR	
	PU15BL	

Table 7 Clearance of random-matching type of PE series Unit: μ m

	Model No.	Fine clearance ZT
Standard type	PE09TR	3 or less
	PE12AR	
	PE15AR	
High-load type	PE09UR	5 or less
	PE12BR	
	PE15BR	

5 Shoulder height of the mounting surface and corner radius r

Figs. 5, 6 and Tables 8, 9 show the shoulder height and corner radius dimensions.

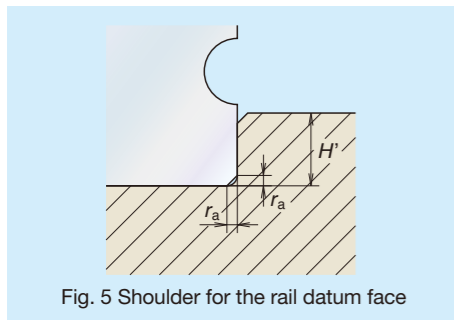

Fig. 5 Shoulder for the rail datum face

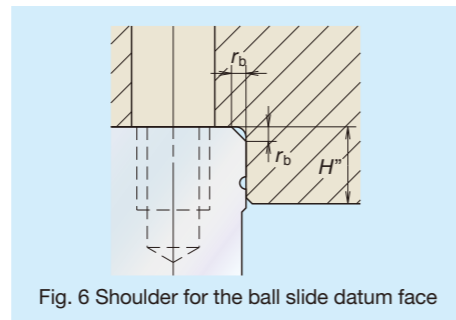

Fig. 6 Shoulder for the ball slide datum face

Table 8 Shoulder height of the mounting surface and corner radius r (PU series) Unit: mm

Model No.	Corner radius (Maximum)		Shoulder height	
	r_a	r_b	H'	$H''^{(*)}$
PU05	0.2	0.2	0.7	2.3
PU07	0.2	0.3	1.2	2.5
PU09	0.3	0.3	1.9	2.6
PU12	0.3	0.3	2.5	3.4
PU15	0.3	0.5	3.5	4.4

^(*) H'' is the minimum recommended value based on the dimension T in Table 13.

Table 9 Shoulder height of the mounting surface and corner radius r (PE series) Unit: mm

Model No.	Corner radius (Maximum)		Shoulder height	
	r_a	r_b	H'	$H''^{(*)}$
PE05	0.2	0.2	1.1	2.5
PE07	0.2	0.3	1.7	3
PE09	0.3	0.3	3.5	2.8
PE12	0.3	0.3	3.5	3.2
PE15	0.3	0.5	3.5	4.1

^(*) H'' is the minimum recommended value based on the dimension T in Table 14.

Lubrication

Selection of grease: Table 10 shows grease that is suitable for the PU series/PE series. We specify PS2 as the standard grease for NSK miniature linear guides.

Table 10 Available greases

Grease code	Thickener	Base oil	Base oil kinematic viscosity mm ² /s (40°C)	Temperature range for use (°C)	Characteristic/Application
PS2	Lithium type	Synthetic oil + Mineral oil	15	-50 to 110	<ul style="list-style-type: none"> For low temperature operation Suitable for high speed and light load application
LG2	Lithium type	Mineral oil + Synthetic hydrocarbon oil	30	-20 to 70	<ul style="list-style-type: none"> For clean environment
LGU	Diurea type	Synthetic hydrocarbon oil	100	-30 to 120	<ul style="list-style-type: none"> For clean environment

Long term maintenance free: NSK K1 Lubrication unit enables long term maintenance free.

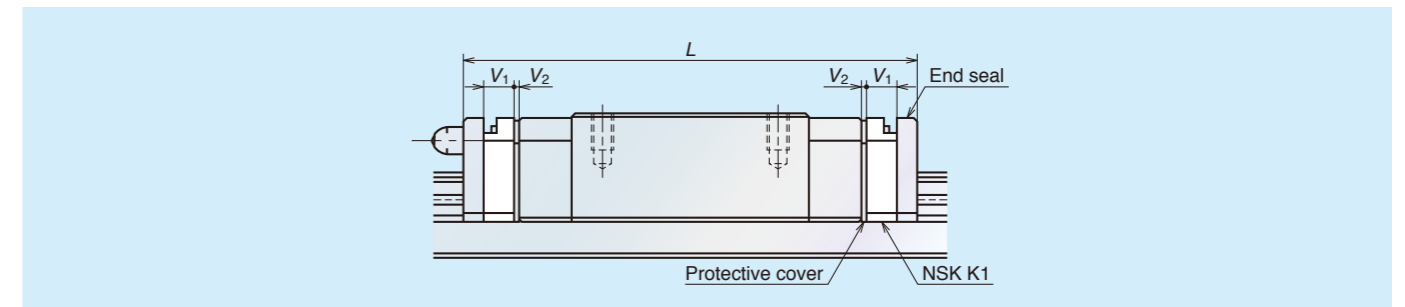

Table 11 Dimensions when equipped with NSK K1 (PU series) Unit: mm

	Model No.	Standard ball slide length	Ball slide length equipped with two NSK K1, L	Thickness of NSK K1, V ₁	Thickness of protective cover, V ₂
Standard type	PU05TR	19.4	24.4	2	0.5
	PU07AR	23.4	29.4	2.5	0.5
	PU09TR	30	36.4	2.7	0.5
	PU12TR	35	42	3	0.5
	PU15AL	43	51.2	3.5	0.6
High-load type	PU09UR	41	47.4	2.7	0.5
	PU12UR	48.7	55.7	3	0.5
	PU15BL	61	69.2	3.5	0.6

Table 12 Dimensions when equipped with NSK K1 (PE series) Unit: mm

	Model No.	Standard ball slide length	Ball slide length equipped with two NSK K1, L	Thickness of NSK K1, V ₁	Thickness of protective cover, V ₂
Standard type	PE05AR	24.1	28.9	2	0.4
	PE07TR	31.1	37.1	2.5	0.5
	PE09TR	39.8	46.8	3	0.5
	PE12AR	45	53	3.5	0.5
	PE15AR	56.6	66.2	4	0.8
High-load type	PE09UR	51.2	58.2	3	0.5
	PE12BR	60	68	3.5	0.5
	PE15BR	76	85.6	4	0.8

Ball slide length equipped with NSK K1 = (Standard ball slide length) + (Thickness of NSK K1, V₁ × Number of NSK K1) + (Thickness of the protective cover, V₂ × 2)
 *Additional NSK K1 is available depending on the use conditions.

7 Dust resistance

End seal: Provided to both sides of the ball slide as a standard feature.

Bottom seal function: It is designed to minimize the clearance between the side faces of rail and the inner walls of the slide, and prevent foreign matters from entering the ball slide.

8 Applications

- Smoother motion and low dust generation
Liquid crystal manufacturing and printed circuit board manufacturing devices
- Lightweight and low dust generation
Semiconductor manufacturing devices (mounter, die bonder, and exposure device)
- Gentler tone and excellent dust resistant features
Medical machinery and various precision devices

9 Dimensions

9.1 Rail and ball slide assembly (preloaded type, random-matching type)

Miniature PU Series/PE Series

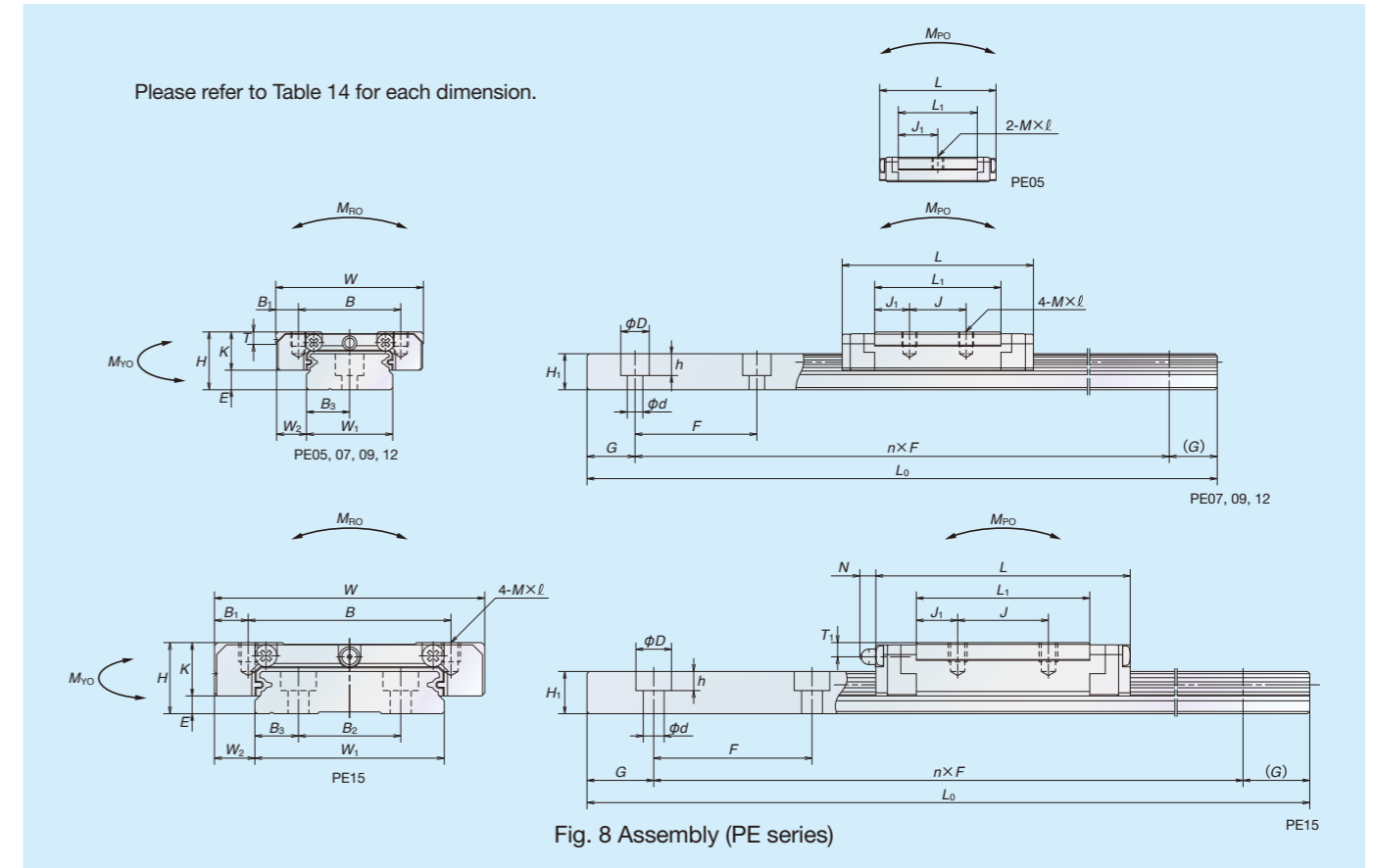
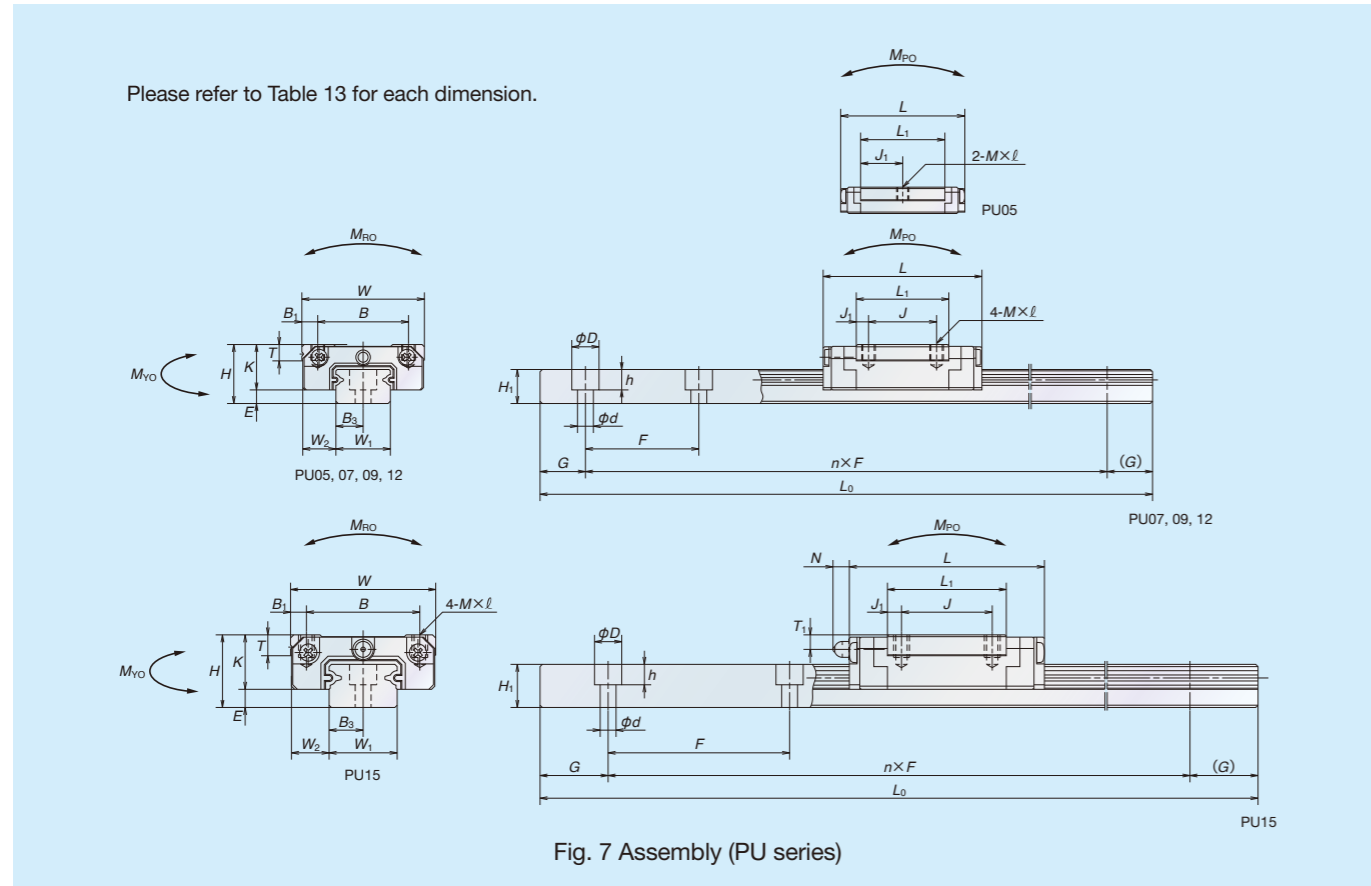

Table 13 Dimensions (PU series)

Model No.	Random-matching type	Assembly		Ball slide											Rail					Basic load rating (*2)						Ball diameter D_w	Weight							
		Height H	E	W_2	Width W	Length L	Mounting hole			B_1	L_1	J_1	K	T	Oil hole			Width W_1	Height H_1	Pitch F	Mounting bolt hole $d \times D \times h$	B_3	G (Reference)	Maximum length L_{0max}	Dynamic C (N)		Static C_0 (N)	Static moment (N-m)				Ball slide (g)	Rail (g/100 mm)	
							B	J	$M \times \text{Pitch} \times \ell$						Hole diameter	T_1	N											one slide	two slides in close contact	one slide	two slides in close contact			
		M_{RO}	M_{PO}	M_{YO}																														
PU05TR	—	6	1	3.5	12	19.4	8	—	M2×0.4×1.5	2	11.4	5.7	5	2.3	∅0.9	1.5	—	5	3.2	15	2.3×3.3×0.8	2.5	5	210	520	775	2.06	1.28	9.90	1.28	9.90	1	4	11
PU07AR	—	8	1.5	5	17	23.4	12	8	M2×0.4×2.4	2.5	13.3	2.65	6.5	2.45	∅1.5	1.8	—	7	4.7	15	2.4×4.2×2.3	3.5	5	375	1 090	1 370	5.20	2.70	21.8	2.70	21.8	1.5875	8	23
PU09TR	○	10	2.2	5.5	20	30	15	10	M3×0.5×3	2.5	19.6	4.8	7.8	2.6	—	—	—	9	5.5	20	3.5×6×4.5	4.5	7.5	600	1 490	2 150	9.90	6.10	41.0	6.10	41.0	1.5875	16	35
PU09UR	○	10	2.2	5.5	20	41	15	16	M3×0.5×3	2.5	30.6	7.3	7.8	2.6	—	—	—	9	5.5	20	3.5×6×4.5	4.5	7.5	600	2 100	3 500	16.2	15.6	88.0	15.6	88.0	1.5875	25	35
PU12TR	○	13	3	7.5	27	35	20	15	M3×0.5×3.5	3.5	20.4	2.7	10	3.4	—	—	—	12	7.5	25	3.5×6×4.5	6	10	800	2 830	3 500	21.1	11.4	73.5	11.4	73.5	2.3812	32	65
PU12UR	○	13	3	7.5	27	48.7	20	20	M3×0.5×3.5	3.5	34.1	7.05	10	3.4	—	—	—	12	7.5	25	3.5×6×4.5	6	10	800	4 000	5 700	34.5	28.3	174	28.3	174	2.3812	53	65
PU15AL	○	16	4	8.5	32	43	25	20	M3×0.5×5	3.5	26.2	3.1	12	4.4	∅3 (*1)	3.2	(3.6)	15	9.5	40	3.5×6×4.5	7.5	15	1 000	5 550	6 600	49.5	25.6	190	25.6	190	3.175	59	105
PU15BL	○	16	4	8.5	32	61	25	25	M3×0.5×5	3.5	44.2	9.6	12	4.4	∅3 (*1)	3.2	(3.6)	15	9.5	40	3.5×6×4.5	7.5	15	1 000	8 100	11 300	84.5	69.5	435	69.5	435	3.175	100	105

○: Random-matching type is available.

(*1) Drive-In grease fitting for ∅3 is available to PU15.

(*2) Basic dynamic load rating is a load that allows for a 50-km rating fatigue life and is a vertical and constant load on the ball slide mounting surface.

To convert C to C_{100} for a 100-km rating fatigue life, divide C by 1.26.

To fix rails of PU05TR, use M2 × 0.4 cross-recessed pan head machine screw for precision instrument.

(JCIS 10-70 No. 0 pan head machine screw No. 1)

(JCIS: Japanese Camera Industrial Standard)

Table 14 Dimensions (PE series)

Model No.	Random-matching type	Assembly		Ball slide											Rail					Basic load rating (*4)						Ball diameter D_w	Weight								
		Height H	E	W_2	Width W	Length L	Mounting hole			B_1	L_1	J_1	K	T	Oil hole			Width W_1	Height H_1	Pitch F	Mounting bolt hole $d \times D \times h$	B_3	G (Reference)	Maximum length L_{0max}	Dynamic C (N)		Static C_0 (N)	Static moment (N-m)				Ball slide (g)	Rail (g/100 mm)		
							B	J	$M \times \text{Pitch} \times \ell$						Hole diameter	T_1	N											one slide	two slides in close contact	one slide	two slides in close contact				
		M_{RO}	M_{PO}	M_{YO}																															
PE05AR	—	6.5	1.4	3.5	17	24.1	13	—	M2.5×0.45×1.5	2	16.4	8.2	5.1	2.5	∅0.9	1.3	—	10	4	—	20	3×5×1.6	5	7.5	150	690	1 160	6.00	2.75	17.5	2.75	17.5	1	7	34
PE07TR	—	9	2	5.5	25	31.1	19	10	M3×0.5×2.8	3	20.8	5.4	7	3	∅1.9	1.9	—	14	5.2	—	30	3.5×6×3.2	7	10	600	1 580	2 350	16.7	7.20	46.0	7.20	46.0	1.5875	19	55
PE09TR	○	12	4	6	30	39.8	21	12	M3×0.5×3	4.5	26.6	7.3	8	2.8	∅2	2.3	—	18	7.5	—	30	3.5×6×4.5	9	10	800	3 000	4 500	36.5	17.3	113	17.3	113	1.5875	35	95
PE09UR	○	12	4	6	30	51.2	23	24	M3×0.5×3	4.5	38	7	8	2.8	∅2	2.3	—	18	7.5	—	30	3.5×6×4.5	9	10	800	4 000	6 700	54.5	37.5	210	37.5	210	1.5875	50	95
PE12AR	○	14	4	8	40	45	28	15	M3×0.5×4	6	31	8	10	3.2	∅2.5	2.7	—	24	8.5	—	40	4.5×8×4.5	12	15	1 000	4 350	6 350	70.5	29.3	180	29.3	180	2.3812	66	140
PE12BR	○	14	4	8	40	60	28	28	M3×0.5×4	6	46	9	10	3.2	∅2.5	2.7	—	24	8.5	—	40	4.5×8×4.5	12	15	1 000	5 800	9 550	106	63.5	345	63.5	345	2.3812	98	140
PE15AR	○	16	4	9	60	56.6	45	20	M4×0.7×4.5	7.5	38.4	9.2	12	4.1	∅3 (*3)	3.2	(3.3)	42	9.5	23	40	4.5×8×4.5	9.5	15	1 200	7 600	10 400	207	59.0	370	59.0	370	3.175	140	275
PE15BR	○	16	4	9	60	76	45	35	M4×0.7×4.5	7.5	57.8	11.4	12	4.1	∅3 (*3)	3.2	(3.3)	42	9.5	23	40	4.5×8×4.5	9.5	15	1 200	10 300	16 000	320	135	740	135	740	3.175	211	275

○: Random-matching type is available.

(*3) Drive-In grease fitting for ∅3 is available to PE15.

(*4) Basic dynamic load rating is a load that allows for a 50-km rating fatigue life and is a vertical and constant load on the ball slide mounting surface.

To convert C to C_{100} for a 100-km rating fatigue life, divide C by 1.26.

To fix rails of PE05AR, use M2.5 × 0.45 cross-recessed pan head machine screw for precision instrument.

(JCIS 10-70 No. 0 pan head machine screw No. 3)

(JCIS: Japanese Camera Industrial Standard)

9.2 Random-matching type

(1) Ball slide of random-matching types

Please refer to Table 13 for each dimension.

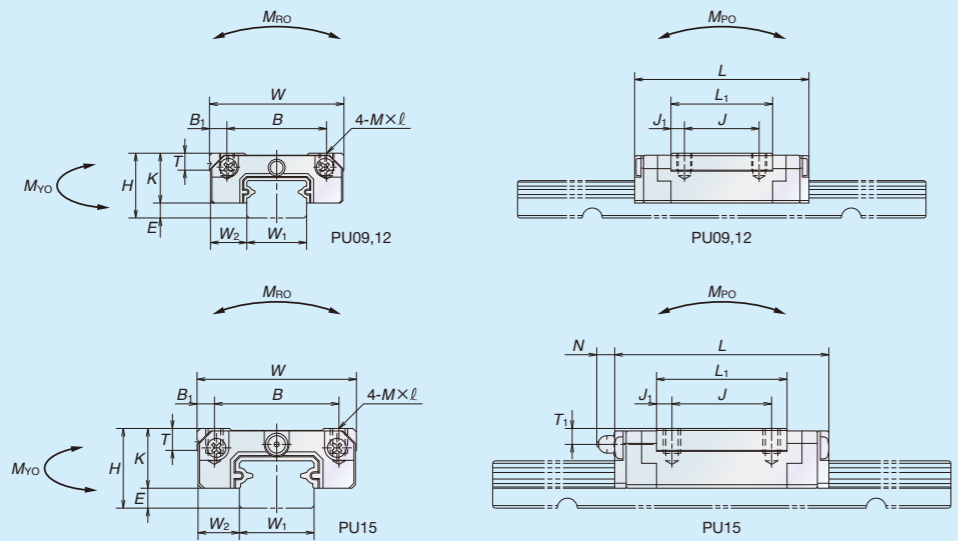

Fig. 9 Ball slide of random-matching types (PU series)

Please refer to Table 14 for each dimension.

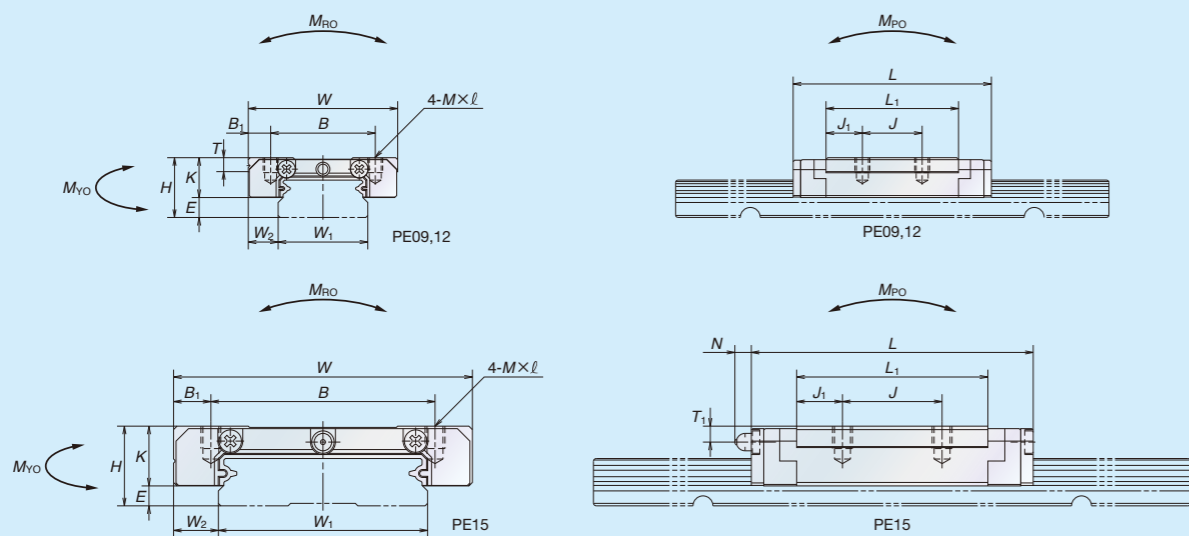

Fig. 10 Ball slide of random-matching types (PE series)

(2) Rail of random-matching types

Please refer to Table 13 for each dimension.

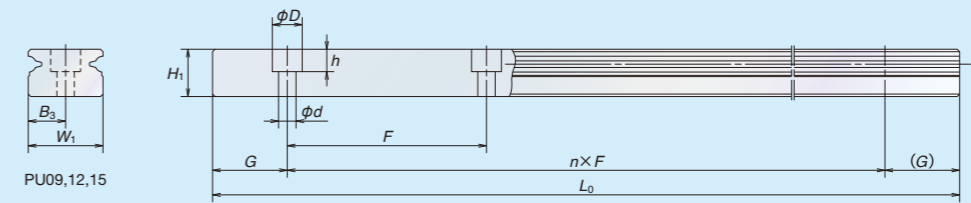

Fig. 11 Rail of random-matching types (PU series)

Please refer to Table 14 for each dimension.

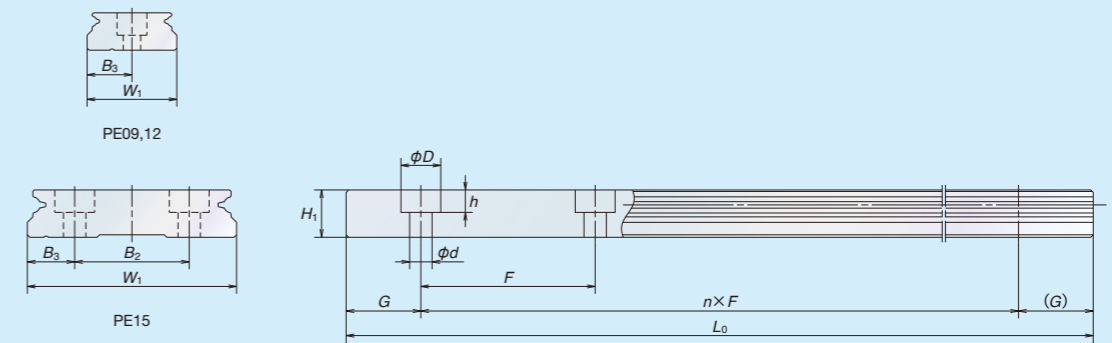

Fig. 12 Rail of random-matching types (PE series)

10 Interchangeability with LU series/LE series

The PU series/PE series is designed to be interchangeable* with the LU series/LE series for its mounting dimensions and load ratings.

Refer to Figs. 7, 8 and Tables 13, 14 for more details.

(*) Load ratings for PU05 and PE05 are not interchangeable

11 Handling precautions

- (1) NSK Linear Guide may become damaged when struck or hit.
- (2) Maximum operating temperature must be 80°C or below. Exceeding this limit may damage resin parts.
- (3) Maximum operating temperature must be 50°C (max. momentary 80°C) when attaching NSK K1. Also, avoid exposure to organic solvents with a degreasing effect. Do not immerse in kerosene or rust preventative oil (with kerosene ingredients).
- (4) Handling of random-matching types
 - ① Random-matching ball slide will be delivered with a provisional rail (inserting fixture).
 - ② Be sure to use the provisional rail when mounting ball slide(s) to a rail.
 - ③ Do not remove the ball slide from provisional rail until inserting into a rail.