

## Solenoid valves VUVG/valve terminal VTUG

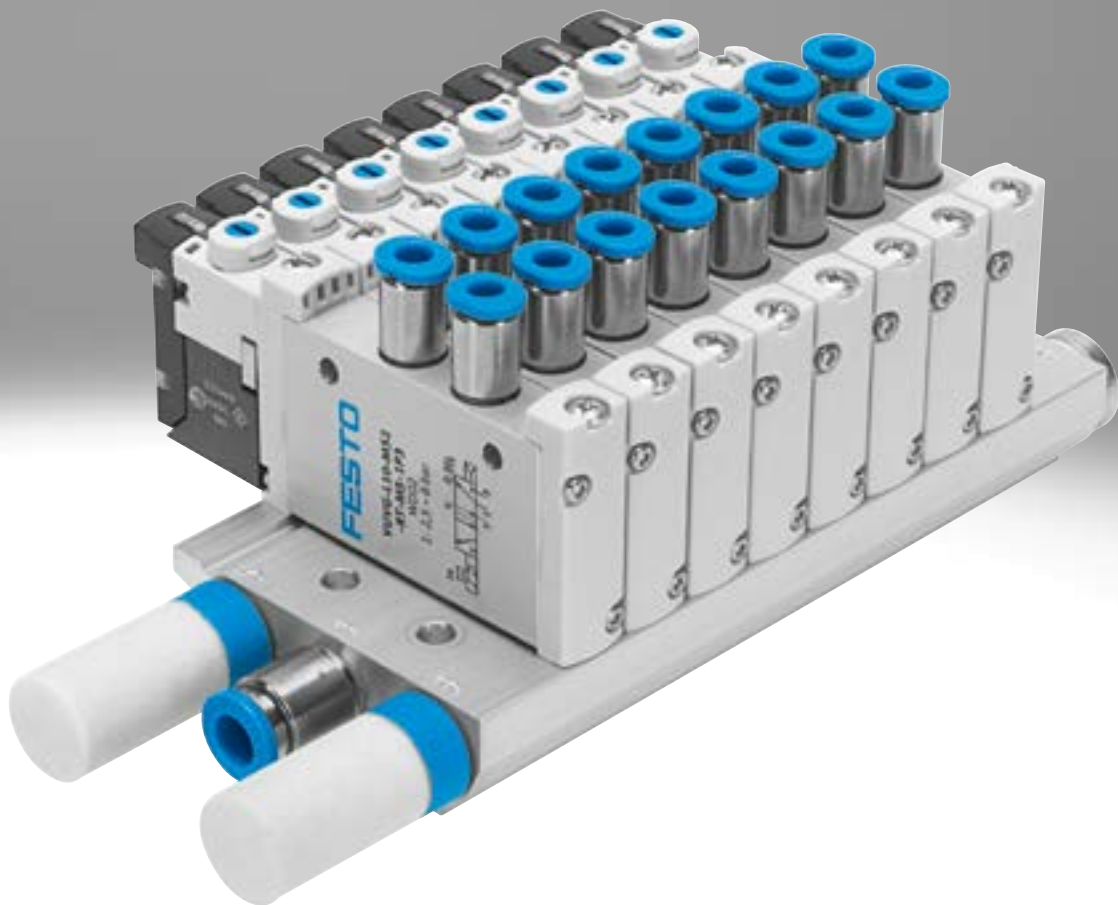

Festo core product range  
Covers 80% of your automation tasks

Worldwide:  
Superb:  
Easy:

Always in stock  
Festo quality at an attractive price  
Simplified procurement and warehousing

★ Generally ready for dispatch from the factory within 24 hours  
In stock at 13 Service Centres worldwide  
More than 2200 products

★ Generally ready for dispatch from the factory within 5 days  
Assembled for you at 4 Service Centres worldwide  
Up to  $6 \times 10^{12}$  variants per product family

Just look  
for the  
star!

Solenoid valves VUVG

Characteristics

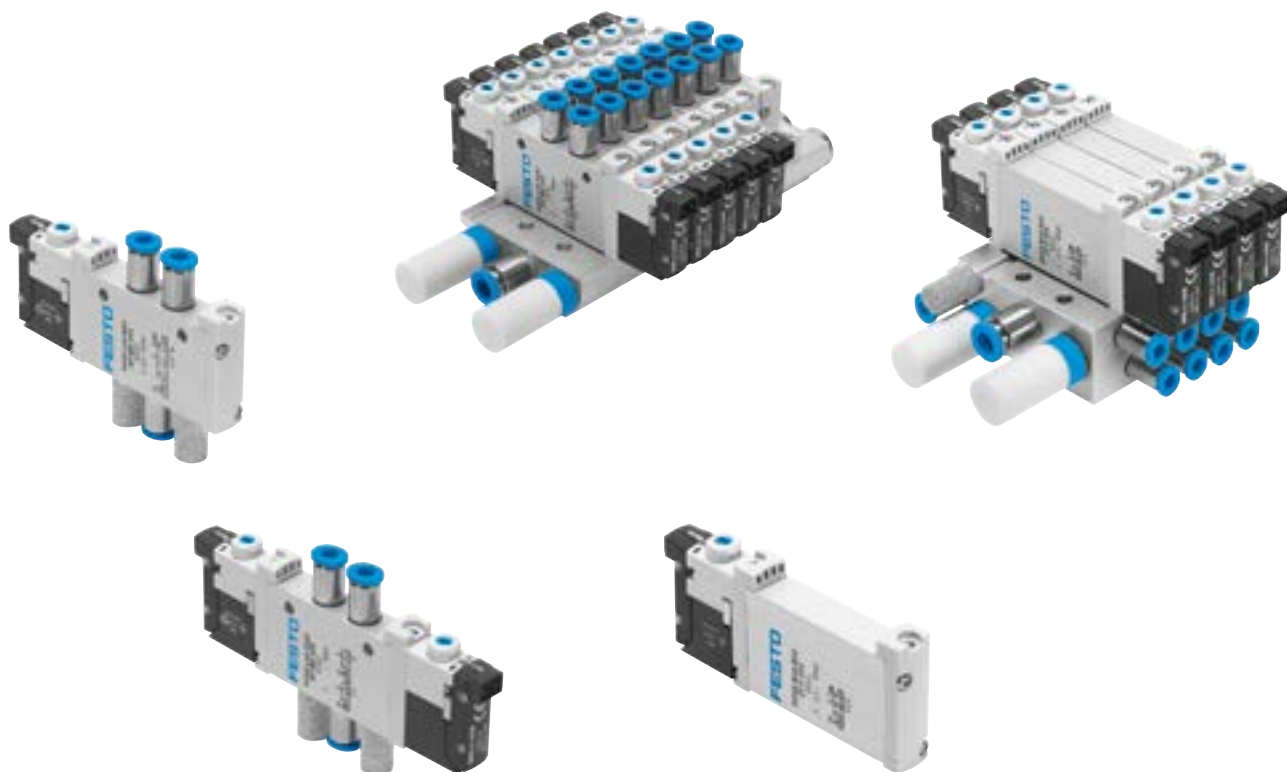

**Innovative**

- Can be set to internal or external pilot air supply for manifold assemblies with sub-base valves
- Maximum pressure 10 bar
- Design principle:
  - Piston spool with sealing ring (VUVG-LK, VUVG-BK)
  - Piston spool with sealing cartridge (VUVG-L, VUVG-B)

**Flexible**

- Wide range of valve functions
- Choice of quick plug connectors
- In-line valves
- Semi in-line valves for manifold assembly
- M5 and M7 in-line valves can be combined on one manifold rail
- Valve manifold assembly with pressure zones
- IP40, IP65
- Connection technology via:
  - E-box

**Reliable**

- Sturdy and durable metal components
  - Valves
  - Manifold rails
- Fast troubleshooting thanks to 360° LED display
- Convenient servicing thanks to valves that can be replaced quickly and easily
- Choice of manual override:
  - non-detenting, covered,
  - non-detenting/detenting or
  - detenting (without accessories)

**Easy to install**

- Secure mounting on wall or H-rail
- Easy mounting, captive screws and seal
- Connection technology easy to change via the E-box
- Identification holder for labelling the valves

**Valve terminal configurator**

A valve terminal configurator is available to help you select a suitable valve terminal VTUG. This makes it much easier to order the right product.

Valve terminals VTUG are ordered via an ident. code. All valve terminals are supplied fully assembled and individually tested.

This reduces assembly and installation time to a minimum.

Download CAD data → [www.festo.com](http://www.festo.com)

Ordering system for valve terminal VTUG  
→ Internet: vtug

## Characteristics – Pneumatic components

### Individual valves and valve manifold assemblies

#### In-line valves as individual valve

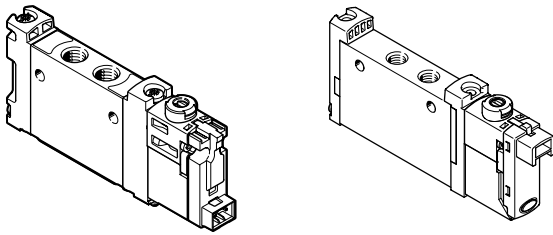

In-line valves are designed to be used without pneumatic linking. All pneumatic connections are on the valve and can be equipped with fittings/tubing. The electrical connection is provided by different E-boxes.

If a special seal set is used, in-line valves VUVG can also be mounted on a manifold rail (pneumatic linking) as semi in-line valves.

#### In-line valve VUVG-LK/VUVG-L

### Semi in-line valves for manifold assembly

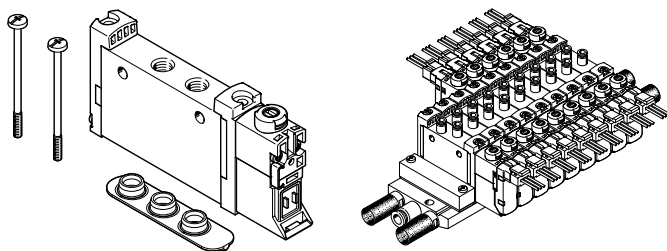

The supply ports (1, 3 and 5) of semi in-line valves are connected to the valve by a pneumatic link (e.g. sub-base).

The working ports (2, 4) are on the valve. The electrical connection is provided by different E-boxes.

#### Semi in-line valve VUVG-S

Valve manifold assembly VTUG comprised of semi in-line valves VUVG-S

### Sub-base valves for manifold assembly

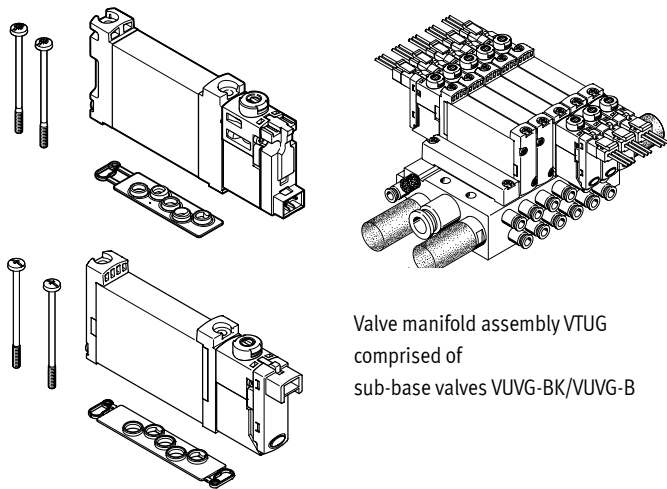

The supply ports (1, 3 and 5) and the working ports (2, 4) of the sub-base valves are connected to the valve by a pneumatic link (e.g. sub-base)

The electrical connection is provided by different E-boxes.

#### Sub-base valve VUVG-BK/VUVG-B

Valve manifold assembly VTUG comprised of sub-base valves VUVG-BK/VUVG-B

## Solenoid valves VUVG

### Characteristics – Pneumatic components

#### Basic valves VUVG

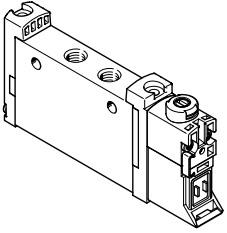

- Size 10, 14 and 18 mm
- In-line valves and semi in-line valves
- Sub-base valves
- 2x 3/2-, 5/2- and 5/3-way valves

#### E-boxes

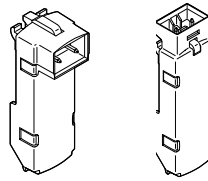

- 5, 12 and 24 V DC
- With or without holding current reduction
- LED

#### Combinations of basic valve and E-boxes

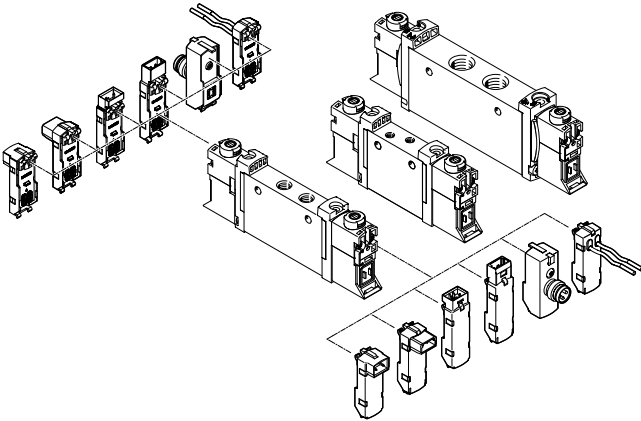

 **Note**  
More E-boxes → page 104

#### Cover caps for manual override

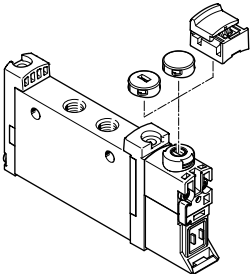

- Closed cover cap, covered manual override
- Slotted cover cap, non-detenting manual override
- Cover, detenting manual override

#### Identification holder

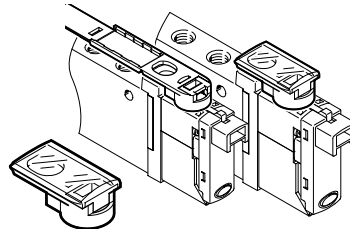

- The identification holder is mounted in the same way as a cover cap for manual override
- The hinged identification holder covers the retaining screw and the manual override



## Characteristics – Pneumatic components

### Manifold rail for in-line valves

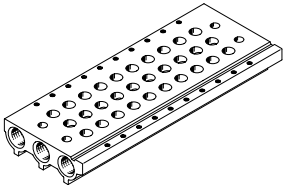

- For in-line valves M3, M5, M7, G1/8 and G1/4
- For 2x 3/2-way, 5/2-way and 5/3-way valves
- 2 to 10 and 12, 14, 16 valve positions

### Manifold rail for sub-base valves

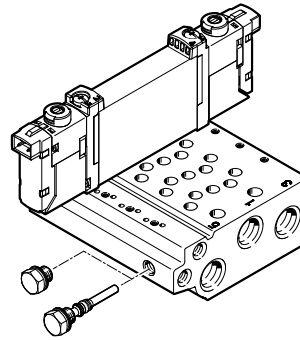

- For sub-base valves 10A, 10, 14 and 18
- Manifold rail with M5, M7, G1/8 and G1/4 working ports
- For 2x 3/2-way, 5/2-way and 5/3-way valves
- 2 to 10, 12, 14 and 16 valve positions
- The sub-base valves always have external pilot air. The pilot air is set via the manifold rail. A short and a long blanking plug are included in the scope of delivery of the manifold rail for this purpose.

### Note

Pressurisation and exhaust at both ends is recommended for an optimised flow rate in cases where multiple valves switch simultaneously.

### Cover plate for vacant position

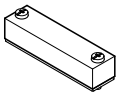

Vacant position cover

### Supply plate

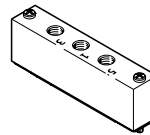

For additional air supply and exhaust via a valve position

### Separator for pressure zones



For creating multiple pressure zones in a valve manifold assembly

Solenoid valves VUVG

Characteristics – Pneumatic components

**Vertical pressure supply plate**

For in-line valves M5/M7 and G1/8

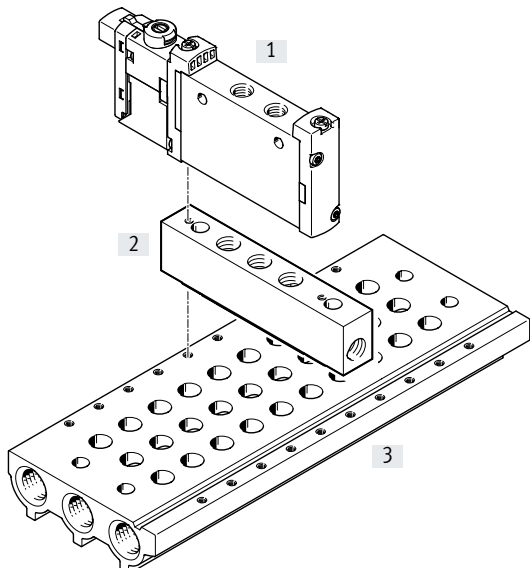

- [1] In-line valves VUVG
- [2] Vertical pressure supply plate
- [3] Manifold rail

The vertical pressure supply plate allows for separate pressurisation and exhausting of the valve mounted on it.  
If two vertical pressure supply plates are mounted one on top of the other, the valve can be supplied with compressed air and exhausted completely independently of the valve terminal (terminal code CS).

Code	Type	For in-line valves		Description
		M5/M7	G1/8	
ZU	VABF-L1-P3A	■	■	Plate with port 1 for supplying an individual operating pressure or separate exhausting (reverse operation) for a valve position.
ZV	VABF-L1-P7A	■	■	Plate with ports 3 and 5 for exhausting the valve or supplying an individual operating pressure (reverse operation) for a valve position.

Characteristics – Pneumatic components

Exhaust functions

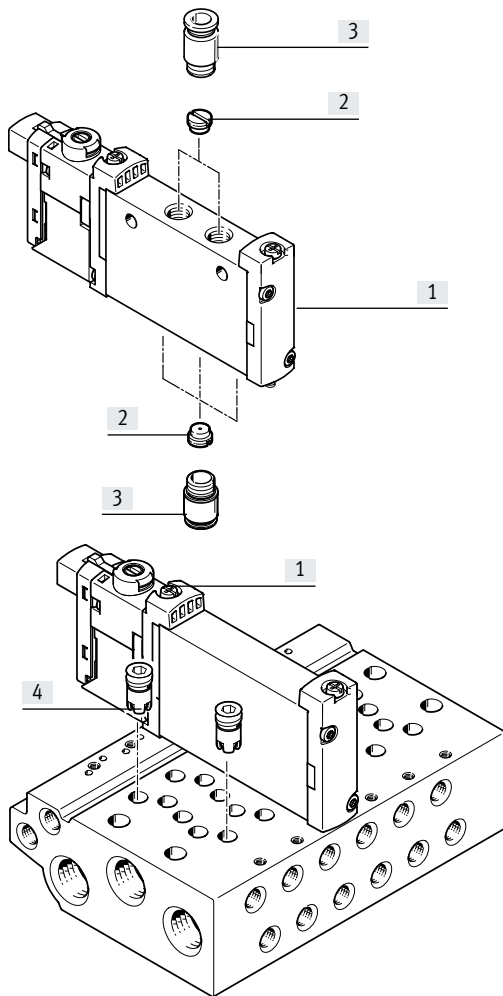

- [1] Valves VUVG with individual electrical connection
- [2] Flow restrictor for thread M5
- [3] Fitting
- [4] Fixed flow restrictor, self-tapping/check valve

Flow restrictor for thread M5

In-line valve, individual electrical connection: flow restrictor can be fitted in port 1, 3, 5 and/or in port 2, 4.

Sub-base valve, individual electrical connection: flow restrictor can be fitted in port 2, 4.

Fixed flow restrictor, self-tapping

The fixed flow restrictor can be used to permanently set the exhaust flow rate in ducts 3 and 5.

The fixed flow restrictors are screwed into ducts 3 and 5 in the manifold rail.

Please see the relevant assembly instructions:

→ [www.festo.com/sp](http://www.festo.com/sp)

Check valve

Check valves block the flow towards the valves if back pressure develops in ducts 3 and 5 in the case of a high exhaust capacity, thereby preventing actuators from switching unexpectedly. The check valves are screwed into ducts 3 and 5 in the manifold rail. Please see the relevant assembly instructions:

→ [www.festo.com/sp](http://www.festo.com/sp)

**Note**

- It is not possible to use a check valve and a fixed flow restrictor (in the same duct) at the same time.
- When screwing in again, use the threads already present.

Solenoid valves VUVG

Characteristics – Pneumatic components

Creating pressure zones and separating exhaust air

Compressed air is supplied and exhausted via the manifold rail and via supply plates.  
The position of the supply plates and duct separations can be freely selected with the VUVG.

Pressure zones are created by isolating the internal supply ducts between the manifold sub-bases by appropriate duct separation.

Pressure zone separation can be used for the following ducts:

- Duct 1
- Duct 3
- Duct 5

- Note**
- Use a separator if the exhaust air pressures are high
  - Use at least one supply plate/supply for each pressure zone
  - Pressure zone separation is not possible in duct 12/14 (pilot air supply)

Duct separation

Description

Pressure zones can be freely configured with the VUVG. The following duct separations are possible:

Duct 1 closed

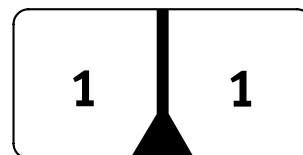

Duct 1, 3, 5 closed

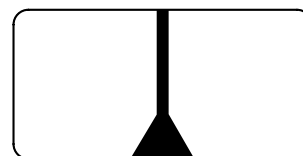

Duct 3, 5 closed

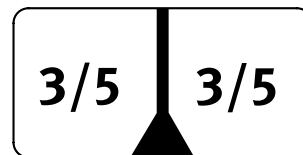

With the VUVG, the number of pressure zones is limited only by the number of valve positions on the manifold rail. Note that each supply plate occupies one valve position.

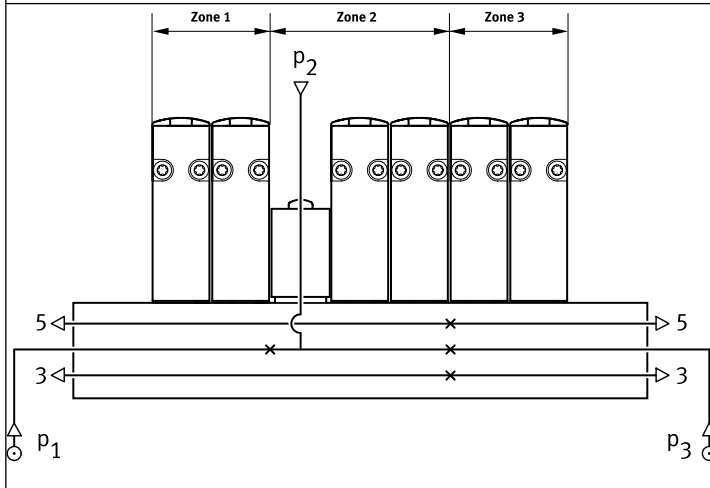
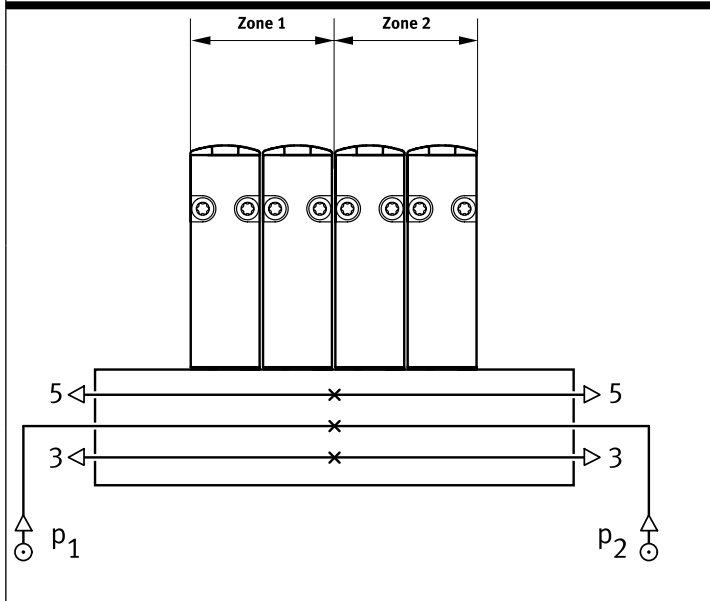

Separator VABD

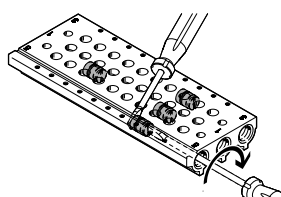

- Note**
- As the separators are fitted from only one side using a slotted screwdriver, several pressure zones can be created in one profile.

## Characteristics – Pneumatic components

### Pilot air supply

#### Internal pilot air supply

Internal pilot air supply can be chosen with an operating pressure in the range 1.5 ... 8 bar, 2.5 ... 8 bar, or 3 ... 8 bar (depending on the valve used).

The pilot air supply is branched from duct 1 (compressed air supply) using an internal connection.

#### External pilot air supply

External pilot air supply is required for vacuum operation. The port for external pilot air supply (port 12/14) is located on the valve in the case of in-line valves and on the manifold rail in the case of sub-base valves.

#### Pilot exhaust air

With in-line valves, the pilot exhaust air escapes via exhaust holes. With sub-base valves, the pilot exhaust air is discharged via duct 82/84 of the manifold rail.

### Pilot air supply with in-line and semi in-line valves

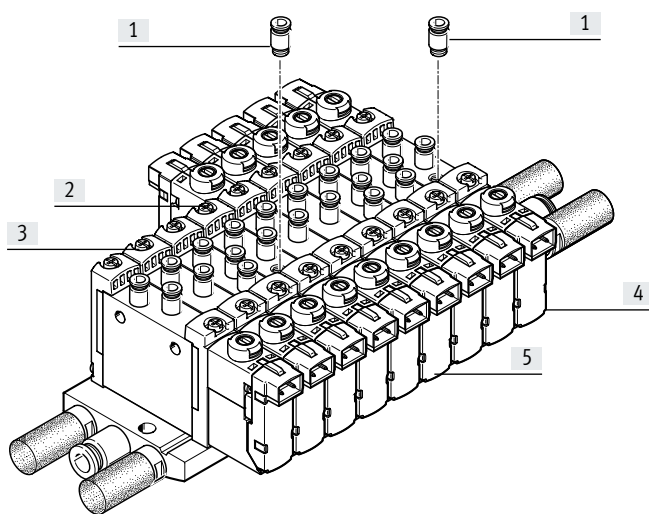

- [1] Push-in fitting for external pilot air supply at port 12/14
- [2] Single solenoid valve with external pilot air supply
- [3] Single solenoid valve with internal pilot air supply
- [4] Double solenoid valve with external pilot air supply
- [5] Double solenoid valve with internal pilot air supply

The internal pilot air is branched from port 1 in the valve body. The external pilot air (port 12/14) is supplied individually at each valve housing.

### Note

Semi in-line valves cannot be supplied centrally with pilot air via the manifold rail.

### Pilot air supply with sub-base valves

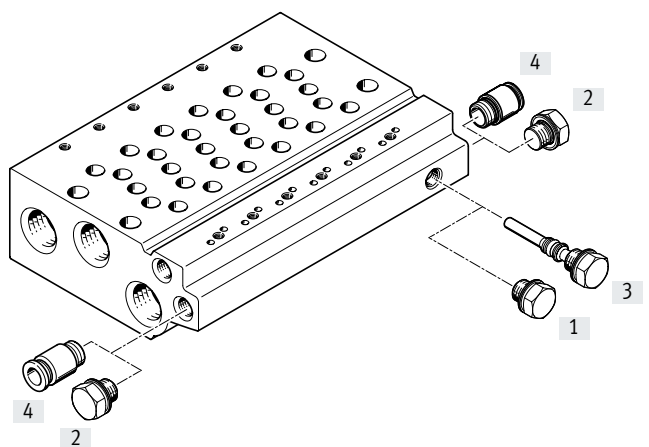

- [1] Blanking plug, short, with internal pilot air
- [2] Blanking plug for duct 12/14 with internal pilot air
- [3] Blanking plug, long, with external pilot air
- [4] Push-in fitting in duct 12/14 with external pilot air

The manifold rails for sub-base valves have an internal connection between duct 12/14 and duct 1. Switching between internal and external pilot air supply is carried out by inserting a blanking plug into this conduit.

Solenoid valves VUVG

Characteristics – Pneumatic components

Operation with different pressures

Vacuum operation

**Points to note with 3/2-way valves**  
The 3/2-way valves are available in a design with two valves in one valve body and with pneumatic spring return. With these valves, the force for the return movement is obtained from port 1.

Vacuum operation is therefore only possible at port 3 and 5, not at port 1.

With external pilot air supply, vacuum can be connected at port 1, 3, 5 of the 5/2-way and 5/3-way valves.

Reverse operation

The 3/2-way valves with pneumatic spring are not suitable for reverse operation, since at least the minimum pilot pressure must be present in duct 1.

 **Note**  
Pressure must be present at port 1.

Pressure deflector (internal pilot air)

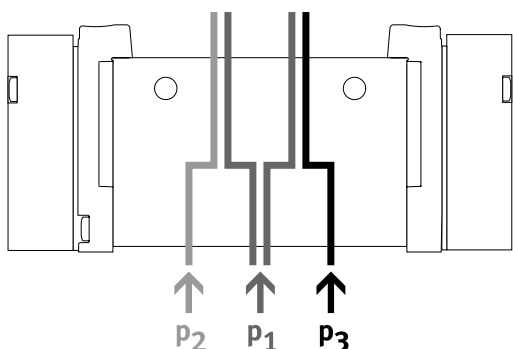

- If two different pressures are required.

- Different pressures can be supplied at duct 1, 3 and 5.

 **Note**

- With internal pilot air supply, the minimum pilot pressure must be adhered to in duct 1
- With 2x3/2-way valves without spring return, the minimum pilot pressure must always be adhered to in duct 1

Advantages

Any pressure or vacuum can be connected at ducts 3 and 5 both with external and internal pilot air.

Vacuum, ejector pulse and normal position

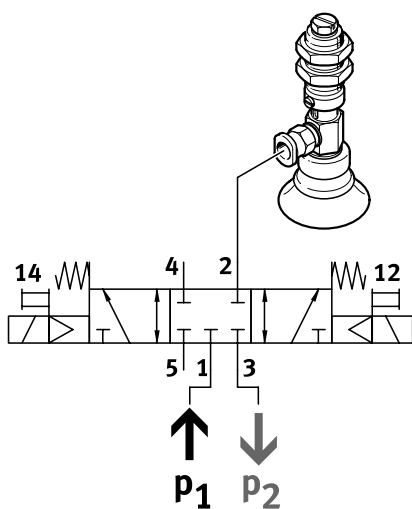

Vacuum, ejector pulse and normal position can be achieved as follows:

- Internal pilot air supply
- Vacuum in duct 3
- Pressure for the ejector pulse in duct 1

Product range overview

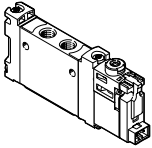
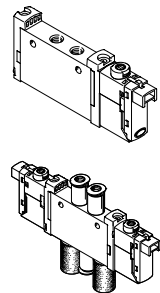
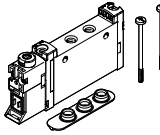
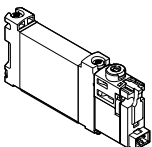
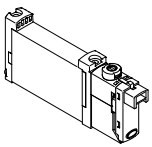
Design	Working port	Size	Functions and flow rate [l/min]												→ Page/ Internet	
			T32C	T32U	T32H	T32C/M	T32U/M	T32H/M	M 52	M52/M	B52	P53C	P53U	P53E		
<b>In-line valve as individual valve, solenoid valve VUVG-LK</b>																
	M5	10	■	-	-	-	-	-	■	-	■	-	-	-	28	
			180	-	-	-	-	-	195	-	195	-	-	-		
	M7	10	■	-	-	-	-	-	■	-	■	-	-	-		32
		280	-	-	-	-	-	340	-	340	-	-	-			
	G1/8	14	■	-	-	-	-	-	■	-	■	-	-	-	47	
			570	-	-	-	-	-	660	-	660	-	-	-		
<b>In-line valve as individual valve, solenoid valve VUVG-L</b>																
	M3	10A	-	-	-	-	-	-	■	■	■	■	■	■	21	
			-	-	-	-	-	-	100	80	100	90	90	90		
	M5	10	■	■	■	■	■	■	■	■	■	■	■	■		36
			150	150	150	135	125	125	220	190	220	210	210	210		
	M7	10	■	■	■	■	■	■	■	■	■	■	■	■		40
		190	190	190	150	140	140	380	320	380	320	320	320			
	G1/8	14	■	■	■	■	■	■	■	■	■	■	■	■	51	
			650	600	650	550	500	500	780	780	780	650	600	600		
	G1/4	18	■	■	■	■	■	■	■	■	■	■	■	■	59	
			1000	1000	1000	1000	1000	1000	1300	1300	1380	1200	1000	1000		
<b>Semi in-line valve for manifold assembly, solenoid valve VUVG-S</b>																
	M3	10A	-	-	-	-	-	-	■	■	■	■	■	■	21	
			-	-	-	-	-	-	100	80	100	90	90	90		
	M5	10	■	■	■	■	■	■	■	■	■	■	■	■		36
			150	150	150	135	125	125	220	190	220	210	210	210		
	M7	10	■	■	■	■	■	■	■	■	■	■	■	■		40
		170	170	170	140	130	130	340	290	340	300	300	300			
	G1/8	14	■	■	■	■	■	■	■	■	■	■	■	■	51	
			620	580	580	520	480	480	730	730	730	620	580	580		
	G1/4	18	■	■	■	■	■	■	■	■	■	■	■	■	59	
			1000	1000	1000	1000	1000	1000	1300	1300	1380	1200	1000	1000		
<b>Sub-base valve, solenoid valve VUVG-BK</b>																
	M5	10	■	-	-	-	-	-	■	-	■	-	-	-	73	
			160	-	-	-	-	-	160	-	160	-	-	-		
	M7	10	■	-	-	-	-	-	■	-	■	-	-	-		73
		160	-	-	-	-	-	160	-	160	-	-	-			
	G1/8	14	■	-	-	-	-	-	■	-	■	-	-	-	84	
			350	-	-	-	-	-	380	-	380	-	-	-		
<b>Sub-base valve, solenoid valve VUVG-B</b>																
	M3	10A	-	-	-	-	-	-	■	■	■	■	■	■	67	
			-	-	-	-	-	-	100	80	100	90	90	90		
	M5	10	■	■	■	■	■	■	■	■	■	■	■	■		77
			150	150	150	130	120	120	210	180	210	200	200	200		
	M7	10	■	■	■	■	■	■	■	■	■	■	■	■		77
		160	160	160	140	130	130	270	230	270	250	250	250			
	G1/8	14	■	■	■	■	■	■	■	■	■	■	■	■	84	
			540	510	540	430	410	410	580	580	580	540	510	510		
	G1/4	18	■	■	■	■	■	■	■	■	■	■	■	■	95	
			800	800	800	800	800	800	1000	1000	1000	950	950	950		



Solenoid valves VUVG

Product range overview

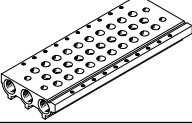
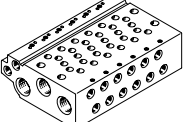
Design	Size	Description	→ Page/ Internet
<b>Manifold rail VABM- ... -S- ... for in-line valves (manifold assembly)</b>			
	10AS	Size M3	27, 45, 57, 65
	10S	Size M5, M7	
	14S	Size G1/8	
	18S	Size G1/4	
<b>Manifold rail VABM, for sub-base valves (manifold assembly)</b>			
	10AW	Size M3	71, 83, 93, 100
	10W	Size M5	
	10HW	Size M7	
	14W	Size G1/8	
	18W	Size G1/4	

Overview of valve functions

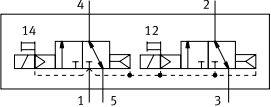
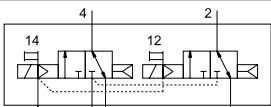
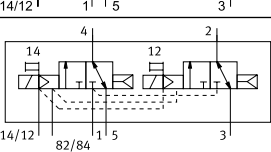
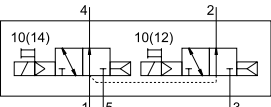
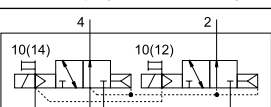
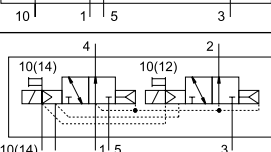
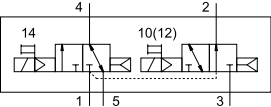
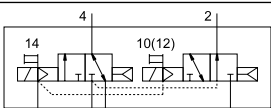
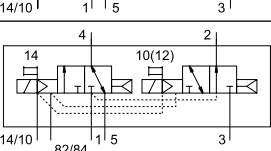

Valve	Valve code	Description	VUVG-LK, VUVG-BK		VUVG-L, VUVG-B			
			Size		Size			
			M5/M7	G1/8	M3	M5/M7	G1/8	G1/4
<b>2x 3/2-way valve, normally closed, pneumatic spring return</b>								
	T32C-A	In-line valve, pilot air supply internal	■	■	-	■	■	■
		In-line valve, pilot air supply external	-	-	-	■	■	-
		Sub-base valve, external pilot air supply	-	-	-	■	■	■
<b>2x 3/2-way valve, normally open, pneumatic spring return</b>								
	T32U-A	In-line valve, pilot air supply internal	-	-	-	■	■	■
		In-line valve, pilot air supply external	-	-	-	■	■	-
		Sub-base valve, external pilot air supply	-	-	-	■	■	■
<b>2x 3/2-way valve, 1x normally open, 1x normally closed, pneumatic spring return</b>								
	T32H-A	In-line valve, pilot air supply internal	-	-	-	■	■	■
		In-line valve, pilot air supply external	-	-	-	■	■	-
		Sub-base valve, external pilot air supply	-	-	-	■	■	■

Solenoid valves VUVG

Overview of valve functions

Valve	Valve code	Description	VUVG-LK, VUVG-BK		VUVG-L, VUVG-B			
			Size		Size			
			M5/M7	G1/8	M3	M5/M7	G1/8	G1/4
<b>2x3/2-way valve, normally closed, mechanical spring</b>								
	T32C-M	In-line valve, pilot air supply internal	-	-	-	■	■	■
		In-line valve, pilot air supply external	-	-	-	■	■	■
		Sub-base valve, external pilot air supply	-	-	-	■	■	■
<b>2x3/2-way valve, normally open, mechanical spring</b>								
	T32U-M	In-line valve, pilot air supply internal	-	-	-	■	■	■
		In-line valve, pilot air supply external	-	-	-	■	■	■
		Sub-base valve, external pilot air supply	-	-	-	■	■	■
<b>2x3/2-way valve, 1x normally open, 1x normally closed, mechanical spring</b>								
	T32H-M	In-line valve, pilot air supply internal	-	-	-	■	■	■
		In-line valve, pilot air supply external	-	-	-	■	■	■
		Sub-base valve, external pilot air supply	-	-	-	■	■	■

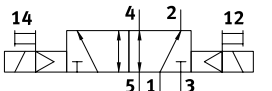
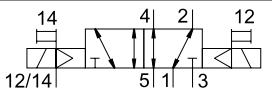
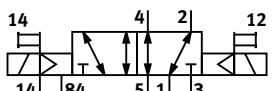
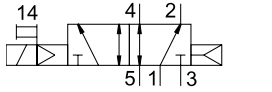
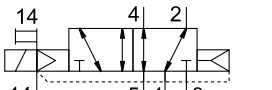
Overview of valve functions

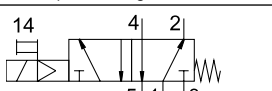
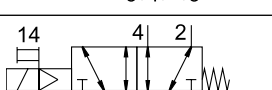
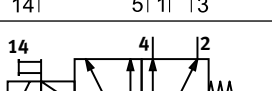
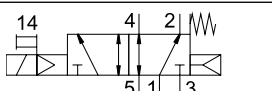
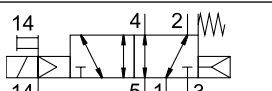
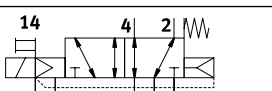
Valve	Valve code	Description	VUVG-LK, VUVG-BK		VUVG-L, VUVG-B			
			Size		Size			
			M5/M7	G1/8	M3	M5/M7	G1/8	G1/4
<b>5/2-way valve, double solenoid</b>								
	B52	In-line valve, pilot air supply internal	■	■	■	■	■	■
		In-line valve, pilot air supply external	-	-	■	■	■	■
		Sub-base valve, external pilot air supply	-	-	■	■	■	■
<b>5/2-way valve, single solenoid, pneumatic spring</b>								
	M52-A	In-line valve, pilot air supply internal	■	■	-	-	■	-
		In-line valve, pilot air supply external	-	-	-	-	■	-
		Sub-base valve, external pilot air supply	-	-	-	-	■	-
<b>5/2-way valve, single solenoid, mechanical spring</b>								
	M52-M	In-line valve, pilot air supply internal	-	-	■	■	■	■
		In-line valve, pilot air supply external	-	-	■	■	■	■
		Sub-base valve, external pilot air supply	-	-	■	■	■	■
<b>5/2-way valve, single solenoid, pneumatic/mechanical spring</b>								
	M52-R	In-line valve, pilot air supply internal	-	-	■	■	-	■
		In-line valve, pilot air supply external	-	-	■	■	-	■
		Sub-base valve, external pilot air supply	-	-	■	■	-	■

Solenoid valves VUVG

Overview of valve functions

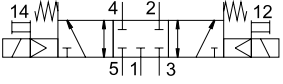
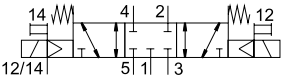
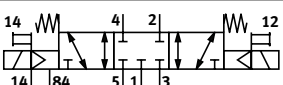
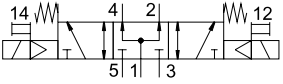
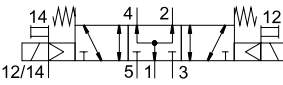
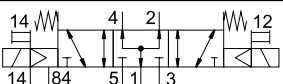
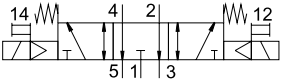
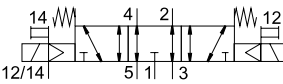
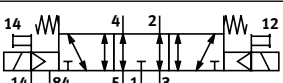
Valve	Valve code	Description	VUVG-LK, VUVG-BK		VUVG-L, VUVG-B			
			Size		Size			
			M5/M7	G1/8	M3	M5/M7	G1/8	G1/4
<b>5/3-way valve, mid-position closed</b>								
	P53C	In-line valve, pilot air supply internal	-	-	■	■	■	■
		In-line valve, pilot air supply external	-	-	■	■	■	■
		Sub-base valve, external pilot air supply	-	-	■	■	■	■
<b>5/3-way valve, mid-position pressurised</b>								
	P53U	In-line valve, pilot air supply internal	-	-	■	■	■	■
		In-line valve, pilot air supply external	-	-	■	■	■	■
		Sub-base valve, external pilot air supply	-	-	■	■	■	■
<b>5/3-way valve, mid-position exhausted</b>								
	P53E	In-line valve, pilot air supply internal	-	-	■	■	■	■
		In-line valve, pilot air supply external	-	-	■	■	■	■
		Sub-base valve, external pilot air supply	-	-	■	■	■	■

Peripherals overview example – In-line valves

Manifold assembly

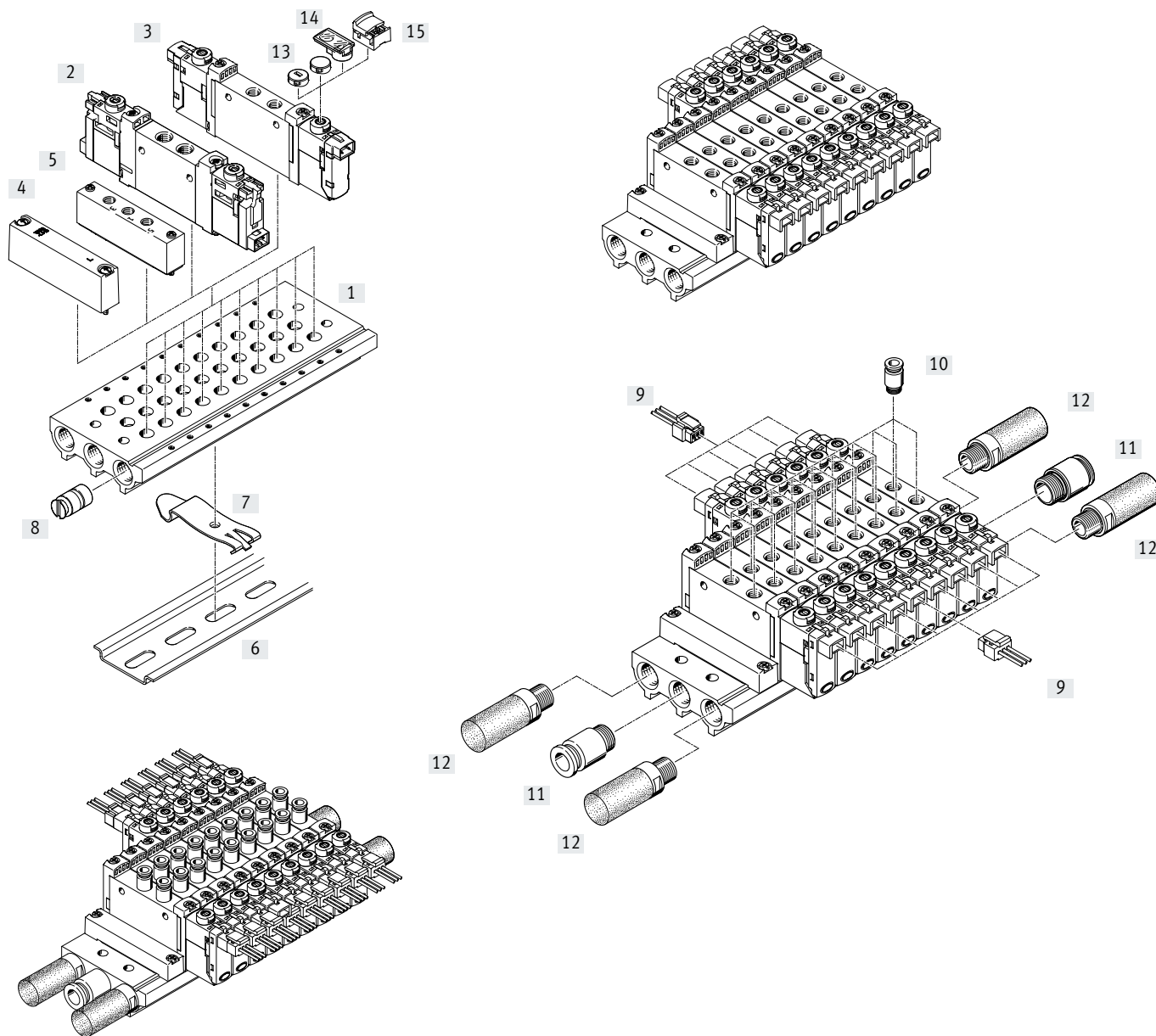

Manifold assembly and accessories

	Type	Description	→ Page/Internet	
[1]	Manifold rail	VABM-L1-...	For 2 to 10, 12, 14 and 16 valve positions	11
[2]	Solenoid valve	VUVG-LK...	In-line valve 2x3/2-way, 5/2-way and 5/3-way	28
[3]	Solenoid valve	VUVG-L...	In-line valve 2x3/2-way, 5/2-way and 5/3-way	28
[4]	Cover plate	VABB-L1-...	For covering a vacant position	27
[5]	Supply plate	VABF-L1-...	For air supply at duct 1 and duct 3 and 5	27
[6]	H-rail	NRH-35-2000	For mounting the valve manifold assembly	200
[7]	H-rail mounting	VAME-T-M4	2 pieces for fitting the valve manifold assembly on an H-rail	200
[8]	Separator	VABD-...	For creating pressure zones	27
[9]	Plug socket with cable	NEBV-H1G2-...-LE2	For E-box H2 and H3	107
[10]	Push-in fitting	QS...	Push-in fitting for duct 2 and 4	108
[11]	Push-in fitting	QS...	Push-in fitting for air supply at duct 1	108
[12]	Silencer	U...	For duct 3 and 5	109
[13]	Cover cap	VMPA-HB...-B	For manual override	198
[14]	Identification holder	ASLR-D	For labelling the valves, covering the retaining screw and the manual override	109
[15]	Cover	VAMC	For manual override	109

Peripherals overview example – Sub-base valves

Manifold assembly

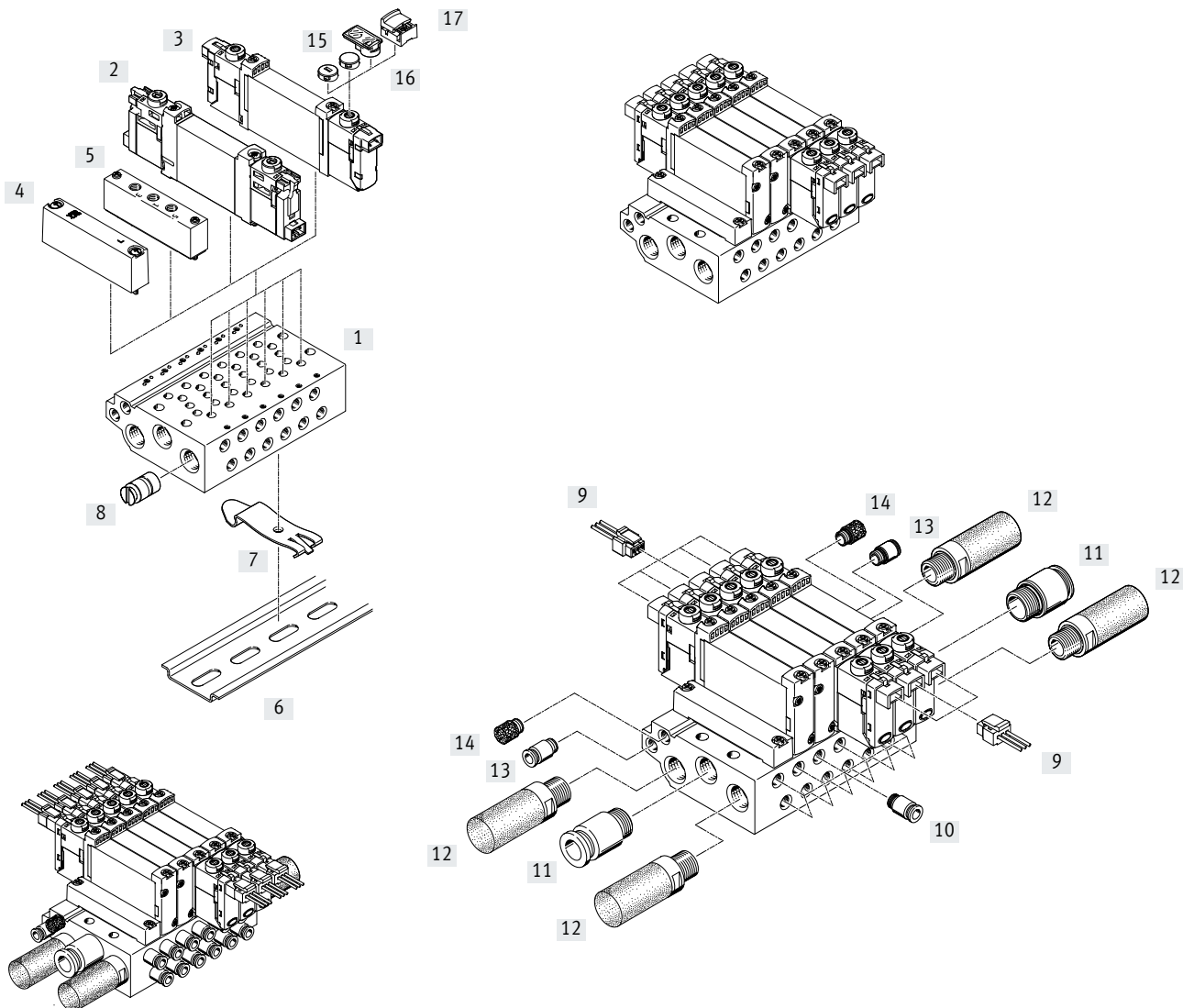

Manifold assembly and accessories

	Type	Description	→ Page/Internet	
[1]	Manifold rail	VABM-L1-...	For 2 to 10, 12, 14 and 16 valve positions	82
[2]	Solenoid valve	VUVG-BK...	Sub-base valve 2x3/2-way, 5/2-way and 5/3-way	73
[3]	Solenoid valve	VUVG-B...	Sub-base valve 2x3/2-way, 5/2-way and 5/3-way	73
[4]	Cover plate	VABB-L1-...	For covering a vacant position	83
[5]	Supply plate	VABF-L1-...	For air supply at duct 1 and duct 3 and 5	83
[6]	H-rail	NRH-35-2000	For mounting the valve manifold assembly	200
[7]	H-rail mounting	VAME-T-M4	2 pieces for fitting the valve manifold assembly on an H-rail	200
[8]	Separator	VABD- ...	For creating pressure zones	83
[9]	Plug socket with cable	NEBV-H1G2-KN-...-LE2	For E-box H2 and H3	107
[10]	Push-in fitting	QS...	Push-in fitting for duct 2 and 4	108
[11]	Push-in fitting	QS...	Push-in fitting for air supply at duct 1	108
[12]	Silencer	U...	For duct 3 and 5	109
[13]	Push-in fitting	QS...	Push-in fitting for pilot air supply at duct 12/14	108
[14]	Silencer	U...	Silencer for pilot air exhaust at duct 82/84	109
[15]	Cover cap	VMPA-HB...-B	For manual override	198
[16]	Identification holder	ASLR-D	For labelling the valves, covering the retaining screw and the manual override	109
[17]	Cover	VAMC	For manual override	109



Type codes

<b>001</b>	<b>Series</b>
<b>VUVG</b>	Solenoid valve
<b>002</b>	<b>Directional control valve type</b>
<b>L</b>	In-line valve
<b>S</b>	Semi-inline valve
<b>B</b>	Sub-base valve
<b>003</b>	<b>Design principle</b>
	Piston spool
<b>K</b>	Piston spool with sealing ring
<b>004</b>	<b>Size</b>
<b>10A</b>	Size 10, deviating flow
<b>10</b>	Size 10
<b>14</b>	Size 14
<b>18</b>	Size 18
<b>005</b>	<b>Valve function</b>
<b>T32U</b>	2x3/2-way valve, normally open
<b>T32C</b>	2x3/2-way valve, normally closed
<b>T32H</b>	2x3/2-way valve, 1x normally closed, 1x normally open
<b>M52</b>	5/2-way valve, single solenoid/monostable
<b>B52</b>	5/2-way valve, double solenoid/bistable
<b>P53U</b>	5/3-way valve, mid-position pressurised
<b>P53E</b>	5/3-way valve, mid-position exhausted
<b>P53C</b>	5/3-way valve, mid-position closed
<b>006</b>	<b>Reset method for monostable/single solenoid valves</b>
	None
<b>A</b>	Pneumatic spring
<b>M</b>	Mechanical spring
<b>R</b>	Mixed, pneumatic/mechanical spring
<b>007</b>	<b>Pilot air</b>
	Internal
<b>Z</b>	External
<b>008</b>	<b>Manual override</b>
	None
<b>H</b>	Non-detenting
<b>T</b>	Non-detenting, detenting with accessories
<b>Y</b>	Detenting
<b>S</b>	Covered

<b>009</b>	<b>Pneumatic connection</b>
<b>F</b>	Flange/sub-base
<b>M3</b>	M3
<b>M5</b>	M5
<b>M7</b>	M7
<b>G18</b>	G1/8
<b>G14</b>	G1/4
<b>Q3</b>	Push-in connector 3 mm
<b>Q4</b>	Push-in connector 4 mm
<b>Q4H</b>	Push-in connector 4 mm, with connecting thread M7
<b>Q6</b>	Push-in connector 6 mm
<b>Q6H</b>	Push-in connector 6 mm, with connecting thread M7
<b>Q8</b>	Push-in connector 8 mm
<b>Q10</b>	Push-in connector 10 mm
<b>T18</b>	Push-in connector 1/8"
<b>T532</b>	Push-in connector 5/32"
<b>T316</b>	Push-in connector 3/16"
<b>T316H</b>	Push-in connector for 3/16", M7
<b>T14</b>	Push-in connector 1/4"
<b>T14H</b>	Push-in connector for 1/4", M7
<b>T38</b>	Push-in connector 3/8"
<b>T516</b>	Push-in connector 5/16"
<b>T516H</b>	Push-in connector 5/16", M7

<b>010</b>	<b>Exhaust</b>
	No fitting
<b>QN</b>	With fitting
<b>U</b>	Silencer

<b>011</b>	<b>Nominal operating voltage</b>
	None
<b>1</b>	24 V DC
<b>4</b>	5 V DC
<b>5</b>	12 V DC

<b>012</b>	<b>Electrical connection</b>
<b>P3</b>	Without electrical sub-base
<b>H2</b>	Connection pattern H, horizontal plug
<b>H3</b>	Connection pattern H, vertical plug
<b>R1</b>	Individual connector M8, 4-pin
<b>R8</b>	Individual connector M8, 3-pin
<b>S2</b>	Connection pattern S, horizontal plug
<b>S3</b>	Connection pattern S, vertical connector
<b>L1</b>	Leads 0.5 m
<b>L2</b>	Leads 1 m
<b>L3</b>	Leads 2.5 m
<b>L4</b>	Leads 5 m
<b>K6</b>	Cable 0.5 m
<b>K7</b>	Cable 1 m
<b>K8</b>	Cable 2.5 m
<b>K9</b>	Cable 5 m

<b>013</b>	<b>Display</b>
	None
<b>L</b>	LED

<b>014</b>	<b>Circuitry</b>
	None
<b>R</b>	Holding current reduction with integrated protective circuit

Solenoid valves VUVG

Type codes



015	Electrical valve accessories	
	None	
<b>C1</b>	Connecting cable, 0.5 m	
<b>C2</b>	Connecting cable 1 m	
<b>C3</b>	Connecting cable 2.5 m	
<b>C4</b>	Connecting cable, 5 m	
<b>N1</b>	Connecting cable 2.5 m, straight plug socket M8, 3-pin	
<b>N2</b>	Connecting cable 5 m, straight plug socket M8, 3-pin	
<b>N3</b>	Connecting cable 2.5 m, angled plug socket M8, 3-pin	
<b>N4</b>	Connecting cable 5 m, angled plug socket M8, 3-pin	
<b>N5</b>	Connecting cable 2.5 m, straight plug socket M8, 4-pin	
<b>N6</b>	Connecting cable 5 m, straight plug socket M8, 4-pin	
<b>N7</b>	Connecting cable 2.5 m, angled plug socket M8, 4-pin	
<b>N8</b>	Connecting cable 5 m, angled plug socket M8, 4-pin	
<b>S1</b>	Connecting cable, 0.5 m, S-connector	
<b>S2</b>	Connecting cable 1 m, S-connector	
<b>S3</b>	Connecting cable 2.5 m, S-connector	
<b>S4</b>	Connecting cable, 5 m, S-plug	
<b>W1</b>	Connecting cable, flying leads, 0.5 m	
<b>W2</b>	Connecting cable, flying leads, 1 m	
<b>W3</b>	Connecting cable, flying leads, 2.5 m	
<b>W4</b>	Connecting cable, flying leads, 5 m	
<b>WS1</b>	Connecting cable, S-plug with flying leads, 0.5 m	
<b>WS2</b>	Connecting cable, S-plug with flying leads, 1 m	
<b>WS3</b>	Connecting cable, S-plug with flying leads, 2.5 m	
<b>WS4</b>	Connecting cable, S-plug with flying leads, 5 m	

016	Version	
	Expanded properties	
<b>S</b>	Focused properties	

Data sheet

Function  
 5/2-way, single solenoid  
 5/2-way, double solenoid valve  
 5/3C, 5/3U, 5/3E

Circuit symbols → page 13

-  - Size 10 mm
-  - Flow rate  
90 ... 100 l/min
-  - Voltage  
5, 12 and 24 V DC



General technical data VUVG-L						
Valve function	M52-R	B52	M52-M	P53		
Normal position	–	–	–	C <sup>1)</sup>	U <sup>2)</sup>	E <sup>3)</sup>
Stable position	Monostable	Bistable	Monostable	Monostable		
Reset method: pneumatic spring	Yes <sup>4)</sup>	–	No	–		
Reset method: mechanical spring	Yes <sup>4)</sup>	–	Yes	Yes		
Vacuum operation at port 1	Only with external pilot air supply					
Design	Piston spool					
Sealing principle	Soft					
Actuation type	Electric					
Type of control	Piloted					
Pilot air supply	Internal or external					
Exhaust air function	Can be throttled					
Manual override	Choice of non-detenting, covered, non-detenting/detenting or detenting					
Type of mounting	Optionally via through-holes <sup>5)</sup> or on manifold rail					
Mounting position	Any					
Nominal size	[mm]	2		1.4	2	
Standard nominal flow rate	[l/min]	100		80	90	
Flow rate on manifold rail	[l/min]	100		80	90	
Switching time on/off	[ms]	7/15	–	7/21	8/25	
Switching time changeover	[ms]	–	5	–	14	
Size	[mm]	10				
Port	1, 2, 3, 4, 5, 12/14	M3				
Product weight	[g]	38	49	37		
Certification	c UL us – Recognized (OL)					
	c CSA us (OL)					
	RCM					
CE marking (see declaration of conformity) <sup>6)</sup>	To EU EMC Directive					
Corrosion resistance class CRC <sup>7)</sup>	2					

- 1) C=Normally closed/mid-position closed
- 2) U=Normally open/mid-position pressurised
- 3) E=Mid-position exhausted
- 4) Combined reset method
- 5) If several valves are to be screwed together via the through-holes to form a block, a minimum distance of 0.3 mm must be ensured by placing spacer discs between them.
- 6) For information about the area of use, see the EC declaration of conformity at: [www.festo.com/sp](http://www.festo.com/sp) → Certificates.  
If the devices are subject to usage restrictions in residential, commercial or light-industrial environments, further measures for the reduction of the emitted interference may be necessary.
- 7) Corrosion resistance class CRC 2 to Festo standard FN 940070  
Moderate corrosion stress. Indoor applications in which condensation can occur. External visible parts with primarily decorative surface requirements which are in direct contact with a normal industrial environment.

## Solenoid valves VUVG-L10A and VUVG-S10A, in-line valves M3

### Data sheet

Operating and environmental conditions			M52-R <sup>1)</sup>	B52	M52-M <sup>2)</sup>	P53
Valve function			Compressed air to ISO 8573-1:2010 [7:4:4]			
Operating pressure	Internal	[bar]	2.5 ... 8	1.5 ... 8	3 ... 8	3 ... 8
	External	[bar]	-0.9 ... 10			-0.9 ... 8
Pilot pressure <sup>3)</sup>		[bar]	2.5 ... 8	1.5 ... 8	3 ... 8	
Ambient temperature		[°C]	-5 ... +50, with holding current reduction -5 ... +60			
Temperature of medium		[°C]	-5 ... +50, with holding current reduction -5 ... +60			

- 1) Mixed, pneumatic/mechanical spring
- 2) Mechanical spring
- 3) Minimum pilot pressure 50% of operating pressure

Electrical data	
Electrical connection	Via E-box → page 102
Operating voltage	[V DC] 5, 12 and 24 ±10%
Power	[W] 1, reduced to 0.35 with holding current reduction
Duty cycle	[%] 100
Degree of protection to EN 60529	IP40 (with plug socket), IP65 (with M8)

Information on materials	
Housing	Wrought aluminium alloy
Seals	HNBR, NBR
Note on materials	RoHS-compliant

Data sheet

Dimensions

5/2-way and 5/3-way valve

Download CAD data → [www.festo.com](http://www.festo.com)

 **Note**  
Additional dimensions  
E-boxes  
→ Page 104

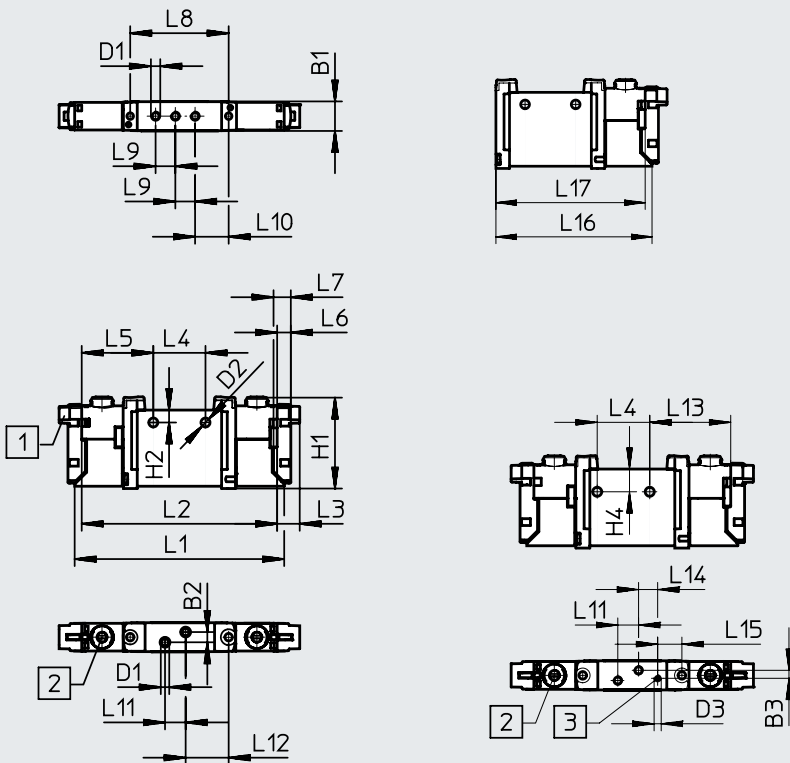

[1] Electrical connection for solenoid valve, horizontal

[2] Manual override

[3] Port for external pilot air supply

Type	B1	B2	B3	D1	D2	D3	H1	H2	L1	L2	L3	L4	L5
VUVG-L10A-...-M3...	10.2	3.6	2.83	M3	3.2	M3	32.5	4.4	74.3	69.3	8	18.5	25.4
VUVG-S10A-...-M3...													

Type	L6	L7	L8	L9	L10	L11	L12	L13	L14	L15	L16	L17
VUVG-L10A-...-M3...	4.85	6.15	34.9	7	11.9	7.3	15.25	28.5	6.7	8.54	57.06	54.56
VUVG-S10A-...-M3...												

Solenoid valves VUVG-L10A and VUVG-S10A, in-line valves M3

Ordering data

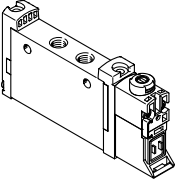
Ordering data	Description	Part no.	Type	
<b>In-line valve M3, without E-box</b>				
	<b>5/2-way valve, single solenoid</b>			
	Internal pilot air supply	Reset method: pneumatic/mechanical spring	566437	VUVG-L10A-M52-RT-M3-1P3
		Reset method: mechanical spring	574345	VUVG-L10A-M52-MT-M3-1P3
	External pilot air supply	Reset method: pneumatic/mechanical spring	566443	VUVG-L10A-M52-RZT-M3-1P3
		Reset method: mechanical spring	574346	VUVG-L10A-M52-MZT-M3-1P3
	<b>5/2-way valve, double solenoid</b>			
	Internal pilot air supply		566438	VUVG-L10A-B52-T-M3-1P3
	External pilot air supply		566444	VUVG-L10A-B52-ZT-M3-1P3
	<b>5/3-way valve</b>			
	Internal pilot air supply	Mid-position closed, reset method: mechanical spring	566439	VUVG-L10A-P53C-T-M3-1P3
		Mid-position exhausted, reset method: mechanical spring	566440	VUVG-L10A-P53E-T-M3-1P3
		Mid-position pressurised, reset method: mechanical spring	566441	VUVG-L10A-P53U-T-M3-1P3
	External pilot air supply	Mid-position closed, reset method: mechanical spring	566445	VUVG-L10A-P53C-ZT-M3-1P3
		Mid-position exhausted, reset method: mechanical spring	566446	VUVG-L10A-P53E-ZT-M3-1P3
Mid-position pressurised, reset method: mechanical spring		566447	VUVG-L10A-P53U-ZT-M3-1P3	

Manifold assembly

In-line valves for manifold assembly



Dimensions

Download CAD data → [www.festo.com](http://www.festo.com)

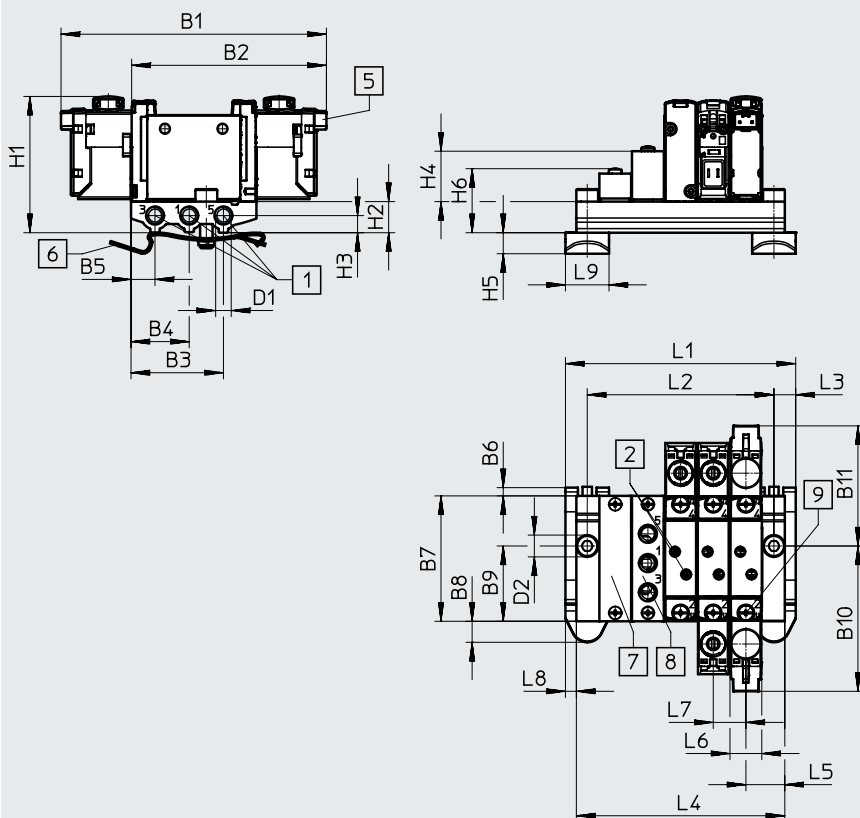

- - **Note**  
 Additional dimensions  
 E-boxes  
 → Page 104

- [1] Ports 1, 3 and 5: M5 (at both ends)
- [2] Ports 2 and 4: M3
- [5] Electrical connection for E-boxes and accessories
- [6] H-rail mounting (two M4x16 screws are required for mounting)
- [7] Cover plate
- [8] Supply plate, ports 1, 3 and 5: M5
- [9] Valves/cover plate mounting on manifold rail: M2 thread

Type	B1	B2	B3	B4	B5	B6	B7	B8	B9	B10	B11	D1
VABM-L1-10AS-M5	85.3	62.6	29.7	18.7	7.7	3	40.3	6.8	24.2	46.7	38.6	M5

Type	D2	H1	H2	H3	H4	H5	H6	L3	L5	L6	L7	L8	L9
VABM-L1-10AS-M5	∅ 4.5	43.8	10	5.5	16.2	6.8	20.3	7	12.5	10.3	10.5	3.5	14

Valve positions	2	3	4	5	6	7	8	9	10	12	14	16
L1	42.5	53	63.5	74	84.5	95	105.5	116	126.5	147.5	168.5	189.5
L2	28.5	39	49.5	60	70.5	81	91.5	102	112.5	133.5	154.5	175.5
L4	35.5	46	56.5	67	77.5	88	98.5	109	119.5	140.5	161.5	182.5
Weight of VABM [g]	26	34	42	50	58	66	74	82	90	106	122	138



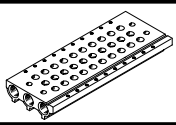

Solenoid valves VUVG-S10A, in-line valves M3

Ordering data

Technical data – Manifold rails							
	Port	CRC	Material <sup>2)</sup>	Operating pressure [bar]	Max. tightening torque for assembly [Nm]		
	1, 3, 5				Valve	H-rail	Wall
	M5	2 <sup>1)</sup>	Wrought aluminium alloy	-0.9 ... 10	0.45	1.5	3

- 1) Corrosion resistance class CRC 2 to Festo standard FN 940070  
Moderate corrosion stress. Indoor applications in which condensation can occur. External visible parts with primarily decorative surface requirements which are in direct contact with a normal industrial environment.
- 2) Note on materials: RoHS-compliant.

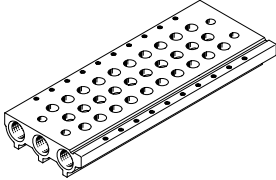
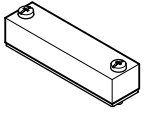

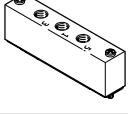
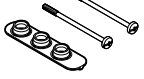
Ordering data

Ordering data – Manifold rail		Description	Part no.	Type
<b>Manifold rail for in-line valves (manifold assembly)</b>				
	For size M3	2 valve positions	566522	VABM-L1-10AS-M5-2
		3 valve positions	566523	VABM-L1-10AS-M5-3
		4 valve positions	566524	VABM-L1-10AS-M5-4
		5 valve positions	566525	VABM-L1-10AS-M5-5
		6 valve positions	566526	VABM-L1-10AS-M5-6
		7 valve positions	566527	VABM-L1-10AS-M5-7
		8 valve positions	566528	VABM-L1-10AS-M5-8
		9 valve positions	566529	VABM-L1-10AS-M5-9
		10 valve positions	566530	VABM-L1-10AS-M5-10
		12 valve positions	566531	VABM-L1-10AS-M5-12
		14 valve positions	566532	VABM-L1-10AS-M5-14
		16 valve positions	566533	VABM-L1-10AS-M5-16
Cover plate <span style="float: right;">Data sheets → Internet: vabb</span>				
	For valve position on manifold rail, including screws and seal	569986	VABB-L1-10A	
Separator <span style="float: right;">Data sheets → Internet: vabd</span>				
	For creating pressure zones	570872	VABD-4.2-B	
Supply plate <span style="float: right;">Data sheets → Internet: vabf</span>				
	For valve position on manifold rail, including screws and seal	569990	VABF-L1-10A-P3A4-M5	
Seals for in-line valves <span style="float: right;">Data sheets → Internet: vabd</span>				
	For in-line valves M3	Delivery quantity: 10 sets (each with 2 screws and 1 seal)	566670	VABD-L1-10AX-S-M3

Solenoid valves VUVG-LK10, in-line valves M5

Data sheet

Function  
2x 3/2C  
5/2-way, single solenoid  
5/2-way, double solenoid valve

-  - Size 10 mm
-  - Flow rate  
180 ... 195 l/min
-  - Voltage  
24 V DC

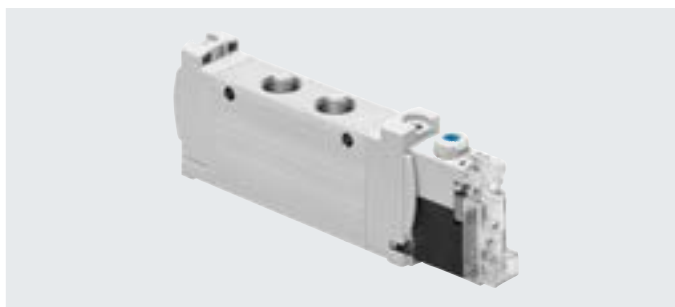

Circuit symbols → page 13

**General technical data VUVG-LK**

Valve function	T32-A	M52-A	B52
Normal position	C <sup>1)</sup>	-	-
Stable position	Monostable		Bistable
Reset method: pneumatic spring	Yes	Yes	-
Design	Piston spool		
Sealing principle	Soft		
Actuation type	Electric		
Type of control	Piloted		
Pilot air supply	Internal		
Exhaust air function	Can be throttled		
Manual override	Detenting, non-detenting		
Type of mounting	Optionally via through-holes <sup>2)</sup> or on manifold rail		
Mounting position	Any		
Standard nominal flow rate	[l/min] 180	195	195
Switching time on/off	[ms] 12/14	14/17	-
Switching time changeover	[ms] -	-	7
Size	[mm] 10		
Port	2, 4	M5	
Product weight	[g] 55	45	57
Corrosion resistance class CRC <sup>3)</sup>	2		

1) C=Normally closed

2) If several valves are to be screwed together via the through-holes to form a block, a minimum distance of 0.3 mm must be ensured by placing spacer discs between them.

3) Corrosion resistance class CRC 2 to Festo standard FN 940070

Moderate corrosion stress. Indoor applications in which condensation can occur. External visible parts with primarily decorative surface requirements which are in direct contact with a normal industrial environment.

**Safety data**

Max. positive test pulse with 0 signal	[µs]	1600
Max. negative test pulse with 1 signal	[µs]	3000
Shock resistance	Shock test with severity level 1 to FN 942017-5 and EN 60068-2-27	
Vibration resistance	Transport application test with severity level 1 to FN 942017-4 and EN 60068-2-6	

Data sheet

Operating and environmental conditions			
Valve function		T32-A <sup>1)</sup>	M52-A <sup>1)</sup>   B52
Operating medium		Compressed air to ISO 8573-1:2010 [7:4:4]	
Note on the operating/pilot medium		Lubricated operation possible (in which case lubricated operation will always be required)	
Operating pressure	[bar]	1.5 ... 7	2.5 ... 7   1.5 ... 7
Ambient temperature	[°C]	-5 ... +50	
Temperature of medium	[°C]	-5 ... +50	

1) Pneumatic spring

Electrical data	
Electrical connection	Via E-box → page 104
Operating voltage	[V DC] 24 ±10%
Power	[W] 0.7
Duty cycle	[%] 100
Degree of protection to EN 60529	IP40 (with plug socket), IP65 (with M8)
Signal status display	LED
Maximum switching frequency	[Hz] 2

Information on materials	
Housing	Wrought aluminium alloy
Seals	HNBR, NBR
Note on materials	RoHS-compliant Contains paint-wetting impairment substances

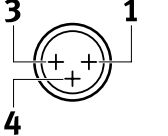
Pin allocation for E-box			
	Pin		Description
<b>Rectangular plug, connection pattern H</b>			
	1	+ or -	Protective circuit without holding current reduction
	2	+ or -	
<b>Round plug, M8, 3-pin</b>			
	1	Not used	Protective circuit without holding current reduction
	3	+ or -	
	4	+ or -	

Protective circuit without holding current reduction

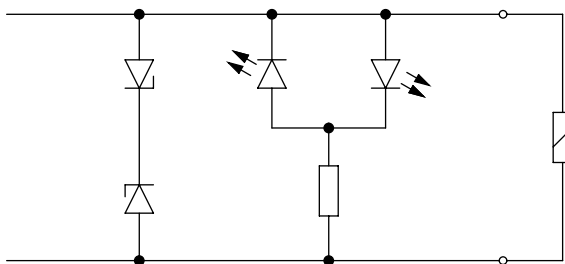

The solenoid coils are equipped with a protective circuit to arrest sparks and protect against polarity reversal.

Data sheet

Dimensions

Download CAD data → [www.festo.com](http://www.festo.com)

2x 3/2-way, 5/2-way valve, double solenoid

5/2-way valve, single solenoid

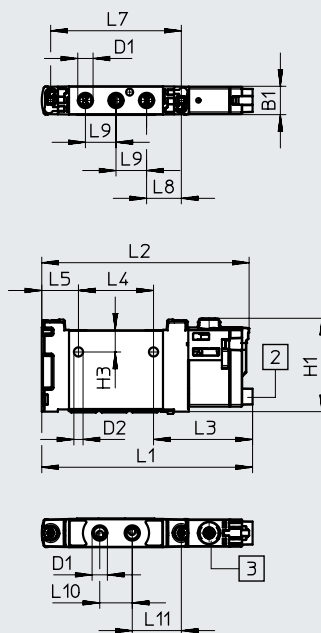
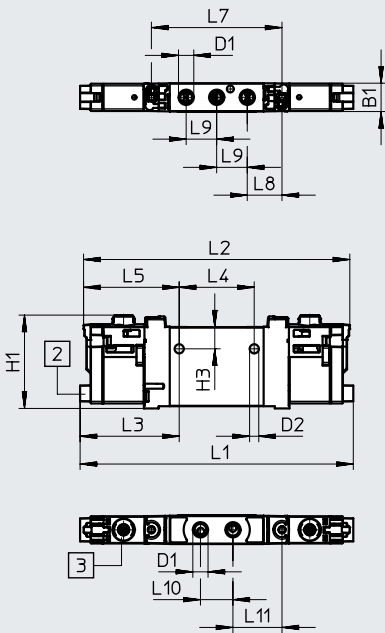

**Note**  
Additional dimensions  
E-boxes  
→ Page 104

[2] Horizontal electrical connection    [3] Manual override

Type	B1	D1	D2	H1	H3	L1	L2	L3	L4
VUVG-LK10-T32C-...-M5...	10.2	M5	3.3	33.6	7.8	98.3	95.8	35.7	27
VUVG-LK10-B52-...-M5...						75.9	74.6		
VUVG-LK10-M52-...-M5...									

Type	L5	L7	L8	L9	L10	L11
VUVG-LK10-T32C-...-M5...	34.4	47	12.5	11	11.7	17.7
VUVG-LK10-B52-...-M5...						
VUVG-LK10-M52-...-M5...	13.2					

Ordering data

★ Core product range

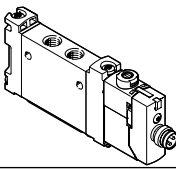
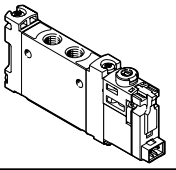
Ordering data	Description	Part no.	Type
<b>In-line valve M5, with E-box R8</b>			
	<b>2x 3/2-way valve</b>		
	Internal pilot air supply	Normally closed, reset method: pneumatic spring	★ 8042542 VUVG-LK10-T32C-AT-M5-1R8L-S
	<b>5/2-way valve, single solenoid</b>		
	Internal pilot air supply	Reset method: pneumatic spring	★ 8042543 VUVG-LK10-M52-AT-M5-1R8L-S
	<b>5/2-way valve, double solenoid</b>		
	Internal pilot air supply	★ 8042544	VUVG-LK10-B52-T-M5-1R8L-S
<b>In-line valve M5, with E-box H2</b>			
	<b>2x 3/2-way valve</b>		
	Internal pilot air supply	Normally closed, reset method: pneumatic spring	★ 8042538 VUVG-LK10-T32C-AT-M5-1H2L-S
	<b>5/2-way valve, single solenoid</b>		
	Internal pilot air supply	Reset method: pneumatic spring	★ 8042539 VUVG-LK10-M52-AT-M5-1H2L-S
	<b>5/2-way valve, double solenoid</b>		
	Internal pilot air supply	★ 8042540	VUVG-LK10-B52-T-M5-1H2L-S

Festo core product range





Generally ready for dispatch from the factory within 24 hours

Generally ready for dispatch from the factory within 5 days

Solenoid valves VUVG-LK10, in-line valves M7

Data sheet

Function  
2x 3/2C  
5/2-way, single solenoid  
5/2-way, double solenoid valve

-  - Size 10 mm
-  - Flow rate  
280 ... 340 l/min
-  - Voltage  
24 V DC

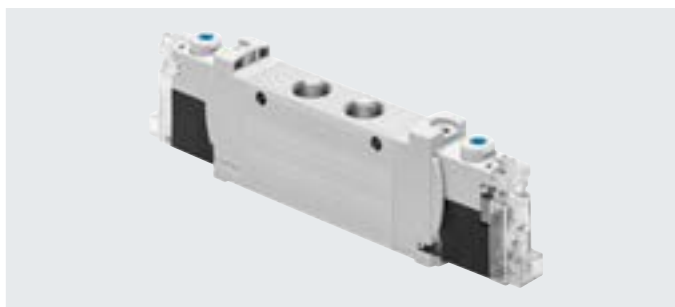

Circuit symbols → page 13

General technical data VUVG-LK

Valve function	T32-A	M52-A	B52
Normal position	C <sup>1)</sup>	-	-
Stable position	Monostable		Bistable
Reset method: pneumatic spring	Yes	Yes	-
Design	Piston spool		
Sealing principle	Soft		
Actuation type	Electric		
Type of control	Piloted		
Pilot air supply	Internal		
Exhaust air function	Can be throttled		
Manual override	Detenting, non-detenting		
Type of mounting	Optionally via through-holes <sup>2)</sup> or on manifold rail		
Mounting position	Any		
Standard nominal flow rate	[l/min] 280	340	340
Switching time on/off	[ms] 12/14	14/17	-
Switching time changeover	[ms] -		7
Size	[mm] 10		
Port	2, 4	M 7	
Product weight	[g] 55	45	57
Corrosion resistance class CRC <sup>3)</sup>	2		

1) C=Normally closed

2) If several valves are to be screwed together via the through-holes to form a block, a minimum distance of 0.3 mm must be ensured by placing spacer discs between them.

3) Corrosion resistance class CRC 2 to Festo standard FN 940070

Moderate corrosion stress. Indoor applications in which condensation can occur. External visible parts with primarily decorative surface requirements which are in direct contact with a normal industrial environment.

Safety data

Max. positive test pulse with 0 signal	[µs]	1600
Max. negative test pulse with 1 signal	[µs]	3000
Shock resistance	Shock test with severity level 1 to FN 942017-5 and EN 60068-2-27	
Vibration resistance	Transport application test with severity level 1 to FN 942017-4 and EN 60068-2-6	



Data sheet

Operating and environmental conditions			
Valve function		T32-A <sup>1)</sup>	M52-A <sup>1)</sup>   B52
Operating medium		Compressed air to ISO 8573-1:2010 [7:4:4]	
Note on the operating/pilot medium		Lubricated operation possible (in which case lubricated operation will always be required)	
Operating pressure	[bar]	1.5 ... 7	2.5 ... 7   1.5 ... 7
Ambient temperature	[°C]	-5 ... +50	
Temperature of medium	[°C]	-5 ... +50	

1) Pneumatic spring

Electrical data	
Electrical connection	Via E-box → page 102
Operating voltage	[V DC] 24 ±10%
Power	[W] 0.7
Duty cycle	[%] 100
Degree of protection to EN 60529	IP40 (with plug socket), IP65 (with M8)
Signal status display	LED
Maximum switching frequency	[Hz] 2

Information on materials	
Housing	Wrought aluminium alloy
Seals	HNBR, NBR
Note on materials	RoHS-compliant Contains paint-wetting impairment substances

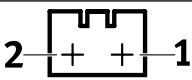
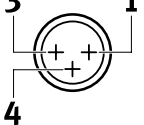
Pin allocation for E-box			
	Pin		Description
<b>Rectangular plug, connection pattern H</b>			
	1	+ or -	Protective circuit without holding current reduction
	2	+ or -	
<b>Round plug, M8, 3-pin</b>			
	1	Not used	Protective circuit without holding current reduction
	3	+ or -	
	4	+ or -	

Protective circuit without holding current reduction

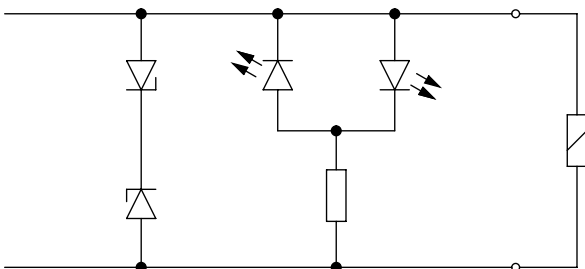

The solenoid coils are equipped with a protective circuit to arrest sparks and protect against polarity reversal.

Data sheet

Dimensions

Download CAD data → [www.festo.com](http://www.festo.com)

2x 3/2-way, 5/2-way valve, double solenoid

5/2-way valve, single solenoid

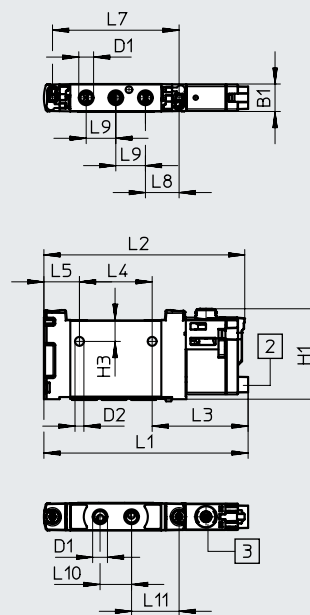
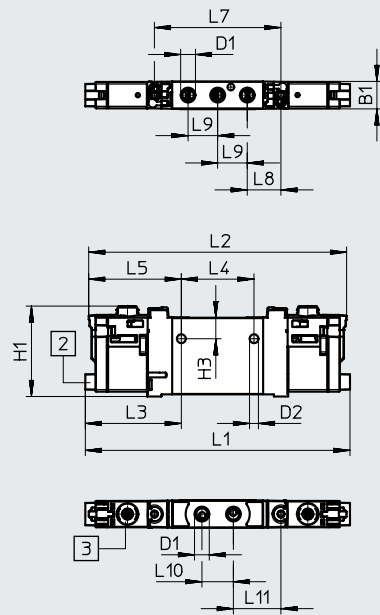

**Note**  
Additional dimensions  
E-boxes  
→ Page 104

[2] Horizontal electrical connection    [3] Manual override

Type	B1	D1	D2	H1	H3	L1	L2	L3	L4
VUVG-LK10-T32C-...-M7...	10.2	M7	3.3	33.6	7.8	98.3	95.8	35.7	27
VUVG-LK10-B52-...-M7...						75.9			
VUVG-LK10-M52-...-M7...									

Type	L5	L7	L8	L9	L10	L11
VUVG-LK10-T32C-...-M7...	34.4	47	12.5	11	11.7	17.7
VUVG-LK10-B52-...-M7...						
VUVG-LK10-M52-...-M7...	13.2					

Ordering data

★ Core product range

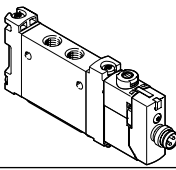
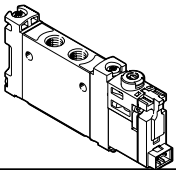
Ordering data		Description	Part no.	Type
<b>In-line valve M7, with E-box R8</b>				
	<b>2x 3/2-way valve</b>			
	Internal pilot air supply	Normally closed, reset method: pneumatic spring	★ 8042550	VUVG-LK10-T32C-AT-M7-1R8L-S
	<b>5/2-way valve, single solenoid</b>			
	Internal pilot air supply	Reset method: pneumatic spring	★ 8042551	VUVG-LK10-M52-AT-M7-1R8L-S
<b>5/2-way valve, double solenoid</b>				
	Internal pilot air supply		★ 8042552	VUVG-LK10-B52-T-M7-1R8L-S
<b>In-line valve M7, with E-box H2</b>				
	<b>2x 3/2-way valve</b>			
	Internal pilot air supply	Normally closed, reset method: pneumatic spring	★ 8042546	VUVG-LK10-T32C-AT-M7-1H2L-S
	<b>5/2-way valve, single solenoid</b>			
	Internal pilot air supply	Reset method: pneumatic spring	★ 8042547	VUVG-LK10-M52-AT-M7-1H2L-S
<b>5/2-way valve, double solenoid</b>				
	Internal pilot air supply		★ 8042548	VUVG-LK10-B52-T-M7-1H2L-S

Festo core product range





Generally ready for dispatch from the factory within 24 hours

Generally ready for dispatch from the factory within 5 days

Solenoid valves VUVG-L10 and VUVG-S10, in-line valves M5

Data sheet

Function  
 2x 3/2C, 2x 3/2U, 2x 3/2H  
 5/2-way, single solenoid  
 5/2-way, double solenoid valve  
 5/3C, 5/3U, 5/3E

-  - Size 10 mm
-  - Flow rate  
125 ... 220 l/min
-  - Voltage  
5, 12 and 24 V DC



Circuit symbols → page 13

General technical data VUVG-L M5														
Valve function	T32-A			T32-M			M52-R	B52	M52-M	P53				
Normal position	C <sup>1)</sup>	U <sup>2)</sup>	H <sup>4)</sup>	C <sup>1)</sup>	U <sup>2)</sup>	H <sup>4)</sup>	-	-	-	C <sup>1)</sup>	U <sup>2)</sup>	E <sup>3)</sup>		
Stable position	Monostable							Bistable	Monostable	Monostable				
Reset method: pneumatic spring	Yes			No			Yes <sup>5)</sup>	-	No	-				
Reset method: mechanical spring	No			Yes			Yes <sup>5)</sup>	-	Yes	Yes				
Vacuum operation at port 1	No			Only with external pilot air supply										
Design	Piston spool													
Sealing principle	Soft													
Actuation type	Electric													
Type of control	Piloted													
Pilot air supply	Internal or external													
Exhaust air function	Can be throttled													
Manual override	Choice of non-detenting, covered, non-detenting/detenting or detenting													
Type of mounting	Optionally via through-holes <sup>6)</sup> or on manifold rail													
Mounting position	Any													
Nominal size	[mm]	2.7		1.9		1.8		3.2		2.2		3.2		
Standard nominal flow rate	[l/min]	150		135		125		220		190		210		
Flow rate on manifold rail	[l/min]	150		135		125		220		190		210		
Switching time on/off	[ms]	6/16		8/11				7/19		-	8/24		10/30	
Switching time changeover	[ms]	-						7		-		15		
Size	[mm]	10												
Port		M5												
	1, 2, 3, 4, 5 12/14	M3												
Product weight	[g]	55			54			45		55		44		55
Certification	c UL us – Recognized (OL)													
	c CSA us (OL)													
	RCM													
CE marking (see declaration of conformity) <sup>7)</sup>	To EU EMC Directive													
Corrosion resistance class CRC <sup>8)</sup>	2													

1) C=Normally closed/mid-position closed  
 2) U=Normally open/mid-position pressurised  
 3) E=Mid-position exhausted  
 4) H=2x 3/2-way valve in one housing with 1x normally closed and 1x normally open  
 5) Combined reset method  
 6) If several valves are to be screwed together via the through-holes to form a block, a minimum distance of 0.3 mm must be ensured by placing spacer discs between them.  
 7) For information about the area of use, see the EC declaration of conformity at: [www.festo.com/sp](http://www.festo.com/sp) → Certificates.  
 If the devices are subject to usage restrictions in residential, commercial or light-industrial environments, further measures for the reduction of the emitted interference may be necessary.  
 8) Corrosion resistance class CRC 2 to Festo standard FN 940070  
 Moderate corrosion stress. Indoor applications in which condensation can occur. External visible parts with primarily decorative surface requirements which are in direct contact with a normal industrial environment.

**Data sheet**

Operating and environmental conditions			T32-A <sup>1)</sup>	T32-M <sup>3)</sup>	M52-R <sup>2)</sup>	B52	M52-M <sup>3)</sup>	P53
Valve function			Compressed air to ISO 8573-1:2010 [7:4:4]					
Operating pressure	Internal	[bar]	1.5 ... 8	2.5 ... 8	2.5 ... 8	1.5 ... 8	3 ... 8	3 ... 8
	External	[bar]	1.5 ... 10	-0.9 ... 10			-0.9 ... 8	-0.9 ... 10
Pilot pressure <sup>4)</sup>		[bar]	1.5 ... 8	2 ... 8	2.5 ... 8	1.5 ... 8	3 ... 8	
Ambient temperature		[°C]	-5 ... +50, with holding current reduction -5 ... +60					
Temperature of medium		[°C]	-5 ... +50, with holding current reduction -5 ... +60					

- 1) Pneumatic spring
- 2) Mixed, pneumatic/mechanical spring
- 3) Mechanical spring
- 4) Minimum pilot pressure 50% of operating pressure

Electrical data	
Electrical connection	Via E-box → page 102
Operating voltage	[V DC] 5, 12 and 24 ±10%
Power	[W] 1, reduced to 0.35 with holding current reduction
Duty cycle	[%] 100
Degree of protection to EN 60529	IP40 (with plug socket), IP65 (with M8)

Information on materials	
Housing	Wrought aluminium alloy
Seals	HNBR, NBR
Note on materials	RoHS-compliant

**Dimensions**

Download CAD data → [www.festo.com](http://www.festo.com)

2x 3/2-way, 5/2-way and 5/3-way valve

- - **Note**  
Additional dimensions  
E-boxes  
→ Page 104

[1] Vertical electrical connection      [2] Horizontal electrical connection      [3] Manual override      [4] Port for external pilot air supply

Type	B1	B2	D1	D2	D3	H1	H2	H3	L1	L2	L3	L4
VUVG-L-10 -...-M5...	10.2	-	M5	3.2	M3	32.5	3.6	4.4	86.5	81.5	8	27
VUVG-S-10 -...-M5...												

Type	L5	L6	L7	L8	L9	L10	L11	L12	L13	L14
VUVG-L-10 -...-M5...	4.85	6.15	47	14	11	12	19	-	69.2	66.7
VUVG-S-10 -...-M5...										

Solenoid valves VUVG-L10 and VUVG-S10, in-line valves M5

Ordering data

★ Core product range

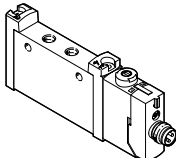
Ordering data		Description	Part no.	Type
<b>In-line valve M5, with E-box R8</b>				
	<b>5/3-way valve</b>			
	Internal pilot air supply	Mid-position closed, reset method: mechanical spring	★ 577346	VUVG-L10-P53C-T-M5-1R8L

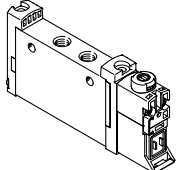
Ordering data		Description	Part no.	Type	
<b>In-line valve M5, without E-box</b>					
	<b>2x 3/2-way valve</b>				
	Internal pilot air supply	Normally closed, reset method: pneumatic spring	566454	VUVG-L10-T32C-AT-M5-1P3	
		Normally open, reset method: pneumatic spring	566455	VUVG-L10-T32U-AT-M5-1P3	
		1x normally open, 1x normally closed, reset method: pneumatic spring	566456	VUVG-L10-T32H-AT-M5-1P3	
		Normally closed, reset method: mechanical spring	574348	VUVG-L10-T32C-MT-M5-1P3	
		Normally open, reset method: mechanical spring	574349	VUVG-L10-T32U-MT-M5-1P3	
		1x normally open, 1x normally closed, reset method: mechanical spring	574350	VUVG-L10-T32H-MT-M5-1P3	
	External pilot air supply	Normally closed, reset method: pneumatic spring	566463	VUVG-L10-T32C-AZT-M5-1P3	
		Normally open, reset method: pneumatic spring	566464	VUVG-L10-T32U-AZT-M5-1P3	
		1x normally open, 1x normally closed, reset method: pneumatic spring	566465	VUVG-L10-T32H-AZT-M5-1P3	
		Normally closed, reset method: mechanical spring	574352	VUVG-L10-T32C-MZT-M5-1P3	
		Normally open, reset method: mechanical spring	574353	VUVG-L10-T32U-MZT-M5-1P3	
		1x normally open, 1x normally closed, reset method: mechanical spring	574354	VUVG-L10-T32H-MZT-M5-1P3	
	<b>5/2-way valve, single solenoid</b>				
	Internal pilot air supply	Reset method: pneumatic/mechanical spring	566457	VUVG-L10-M52-RT-M5-1P3	
Reset method: mechanical spring		574351	VUVG-L10-M52-MT-M5-1P3		
External pilot air supply	Reset method: pneumatic/mechanical spring	566466	VUVG-L10-M52-RZT-M5-1P3		
	Reset method: mechanical spring	574355	VUVG-L10-M52-MZT-M5-1P3		

Festo core product range



Generally ready for dispatch from the factory within 24 hours  
 Generally ready for dispatch from the factory within 5 days

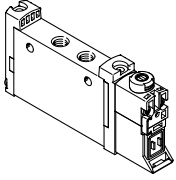
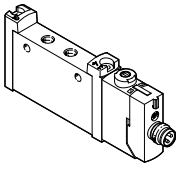
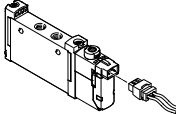
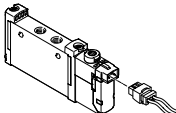

Ordering data

Ordering data	Description	Part no.	Type	
<b>In-line valve M5, without E-box</b>				
	<b>5/2-way valve, double solenoid</b>			
	Internal pilot air supply	566458	VUVG-L10-B52-T-M5-1P3	
	External pilot air supply	566467	VUVG-L10-B52-ZT-M5-1P3	
	<b>5/3-way valve</b>			
	Internal pilot air supply	Mid-position closed, reset method: mechanical spring	566459	VUVG-L10-P53C-T-M5-1P3
		Mid-position exhausted, reset method: mechanical spring	566460	VUVG-L10-P53E-T-M5-1P3
		Mid-position pressurised, reset method: mechanical spring	566461	VUVG-L10-P53U-T-M5-1P3
	External pilot air supply	Mid-position closed, reset method: mechanical spring	566468	VUVG-L10-P53C-ZT-M5-1P3
		Mid-position exhausted, reset method: mechanical spring	566469	VUVG-L10-P53E-ZT-M5-1P3
Mid-position pressurised, reset method: mechanical spring		566470	VUVG-L10-P53U-ZT-M5-1P3	
<b>In-line valve M5, with E-box R8</b>				
	<b>2x 3/2-way valve</b>			
	Internal pilot air supply	Normally closed, reset method: pneumatic spring	577347	VUVG-L10-T32C-AT-M5-1R8L
		Normally open, reset method: pneumatic spring	8031466	VUVG-L10-T32U-AT-M5-1R8L
		1x normally open, 1x normally closed, reset method: pneumatic spring	8031467	VUVG-L10-T32H-AT-M5-1R8L
		Normally closed, reset method: mechanical spring	8031468	VUVG-L10-T32C-MT-M5-1R8L
		Normally open, reset method: mechanical spring	8031469	VUVG-L10-T32U-MT-M5-1R8L
		1x normally open, 1x normally closed, reset method: mechanical spring	8031470	VUVG-L10-T32H-MT-M5-1R8L
	<b>5/2-way valve, single solenoid</b>			
	Internal pilot air supply	Reset method: pneumatic/mechanical spring	572634	VUVG-L10-M52-RT-M5-1R8L
		Reset method: mechanical spring	8031472	VUVG-L10-M52-MT-M5-1R8L
	<b>5/2-way valve, double solenoid</b>			
	Internal pilot air supply	576664	VUVG-L10-B52-T-M5-1R8L	
	<b>5/3-way valve</b>			
	Internal pilot air supply	Mid-position exhausted, reset method: mechanical spring	8031475	VUVG-L10-P53E-T-M5-1R8L
Mid-position pressurised, reset method: mechanical spring		8031476	VUVG-L10-P53U-T-M5-1R8L	
<b>In-line valve M5, with E-box H2</b>				
	<b>5/2-way valve, single solenoid</b>			
	Internal pilot air supply	Reset method: pneumatic/mechanical spring	577316	VUVG-L10-M52-RT-M5-1H2L-W1
		Reset method: mechanical spring	578162	VUVG-L10-M52-MT-M5-1H2L-W1
	<b>5/2-way valve, double solenoid</b>			
Internal pilot air supply	577317	VUVG-L10-B52-T-M5-1H2L-W1		
<b>Semi in-line valve M5, with E-box H2</b>				
	<b>5/2-way valve, single solenoid</b>			
	Internal pilot air supply	Reset method: pneumatic/mechanical spring	577324	VUVG-S10-M52-RT-M5-1H2L-W1

Solenoid valves VUVG-L10 and VUVG-S10, in-line valves M7

Data sheet

Function  
 2x 3/2C, 2x 3/2U, 2x 3/2H  
 5/2-way, single solenoid  
 5/2-way, double solenoid valve  
 5/3C, 5/3U, 5/3E

-  - Size 10 mm
-  - Flow rate  
170 ... 340 l/min
-  - Voltage  
5, 12 and 24 V DC

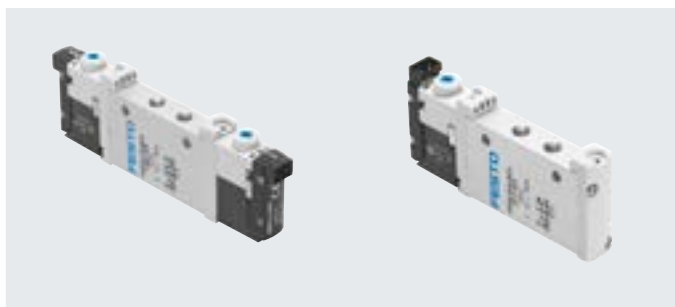

Circuit symbols → page 13

General technical data VUVG-L M7

Valve function	T32-A			T32-M			M52-R	B52	M52-M	P53			
Normal position	C <sup>1)</sup>	U <sup>2)</sup>	H <sup>4)</sup>	C <sup>1)</sup>	U <sup>2)</sup>	H <sup>4)</sup>	-	-	-	C <sup>1)</sup>	U <sup>2)</sup>	E <sup>3)</sup>	
Stable position	Monostable							Bistable	Monostable	Monostable			
Reset method: pneumatic spring	Yes			No			Yes <sup>5)</sup>	-	No	-			
Reset method: mechanical spring	No			Yes			Yes <sup>5)</sup>	-	Yes	Yes			
Vacuum operation at port 1	No			Only with external pilot air supply									
Design	Piston spool												
Sealing principle	Soft												
Actuation type	Electric												
Type of control	Piloted												
Pilot air supply	Internal or external												
Exhaust air function	Can be throttled												
Manual override	Choice of non-detenting, covered, non-detenting/detenting or detenting												
Type of mounting	Optional via through-holes <sup>6)</sup> or on manifold rail												
Mounting position	Any												
Nominal size	[mm]	2.7			2.0	1.9	1.9	4.0		2.8	3.5		
Standard nominal flow rate	[l/min]	190			150	140	140	330	380	220	320		
Flow rate on manifold rail	[l/min]	170			140	130	130	330	340	220	300		
Switching time on/off	[ms]	6/16			8/11			7/19		-	8/24		10/30
Switching time changeover	[ms]	-			-			7		-	15		
Size	[mm]	10											
Port		M7											
	1, 2, 3, 4, 5 12/14	M3											
Product weight	[g]	55			54			45	55	44	55		
Certification	c UL us – Recognized (OL)												
	c CSA us (OL)												
	RCM												
CE marking (see declaration of conformity) <sup>7)</sup>	To EU EMC Directive												
Corrosion resistance class CRC <sup>8)</sup>	2												

- 1) C=Normally closed/mid-position closed
- 2) U=Normally open/mid-position pressurised
- 3) E=Mid-position exhausted
- 4) H=2x 3/2-way valve in one housing with 1x normally closed and 1x normally open
- 5) Combined reset method
- 6) If several valves are to be screwed together via the through-holes to form a block, a minimum distance of 0.3 mm must be ensured by placing spacer discs between them.
- 7) For information about the area of use, see the EC declaration of conformity at: [www.festo.com/sp](http://www.festo.com/sp) → Certificates.  
If the devices are subject to usage restrictions in residential, commercial or light-industrial environments, further measures for the reduction of the emitted interference may be necessary.
- 8) Corrosion resistance class CRC 2 to Festo standard FN 940070  
Moderate corrosion stress. Indoor applications in which condensation can occur. External visible parts with primarily decorative surface requirements which are in direct contact with a normal industrial environment.



Data sheet

Operating and environmental conditions			T32-A <sup>1)</sup>	T32-M <sup>3)</sup>	M52-R <sup>2)</sup>	B52	M52-M <sup>3)</sup>	P53
Valve function			Compressed air to ISO 8573-1:2010 [7:4:4]					
Operating pressure	Internal	[bar]	1.5 ... 8	2.5 ... 8	2.5 ... 8	1.5 ... 8	3 ... 8	
	External	[bar]	1.5 ... 10	-0.9 ... 10			-0.9 ... 8	-0.9 ... 10
Pilot pressure <sup>4)</sup>		[bar]	1.5 ... 8	2 ... 8	2.5 ... 8	1.5 ... 8	3 ... 8	3 ... 8
Ambient temperature		[°C]	-5 ... +50, with holding current reduction -5 ... +60					
Temperature of medium		[°C]	-5 ... +50, with holding current reduction -5 ... +60					

- 1) Pneumatic spring
- 2) Mixed, pneumatic/mechanical spring
- 3) Mechanical spring
- 4) Minimum pilot pressure 50% of operating pressure

Electrical data	
Electrical connection	Via E-box → page 102
Operating voltage	[V DC] 5, 12, 24 ±10%
Power	[W] 1, reduced to 0.35 with holding current reduction
Duty cycle	[%] 100
Degree of protection to EN 60529	IP40 (with plug socket), IP65 (with M8)

Information on materials	
Housing	Wrought aluminium alloy
Seals	HNBR, NBR
Note on materials	RoHS-compliant

Dimensions Download CAD data → [www.festo.com](http://www.festo.com)

2x 3/2-way, 5/2-way and 5/3-way valve

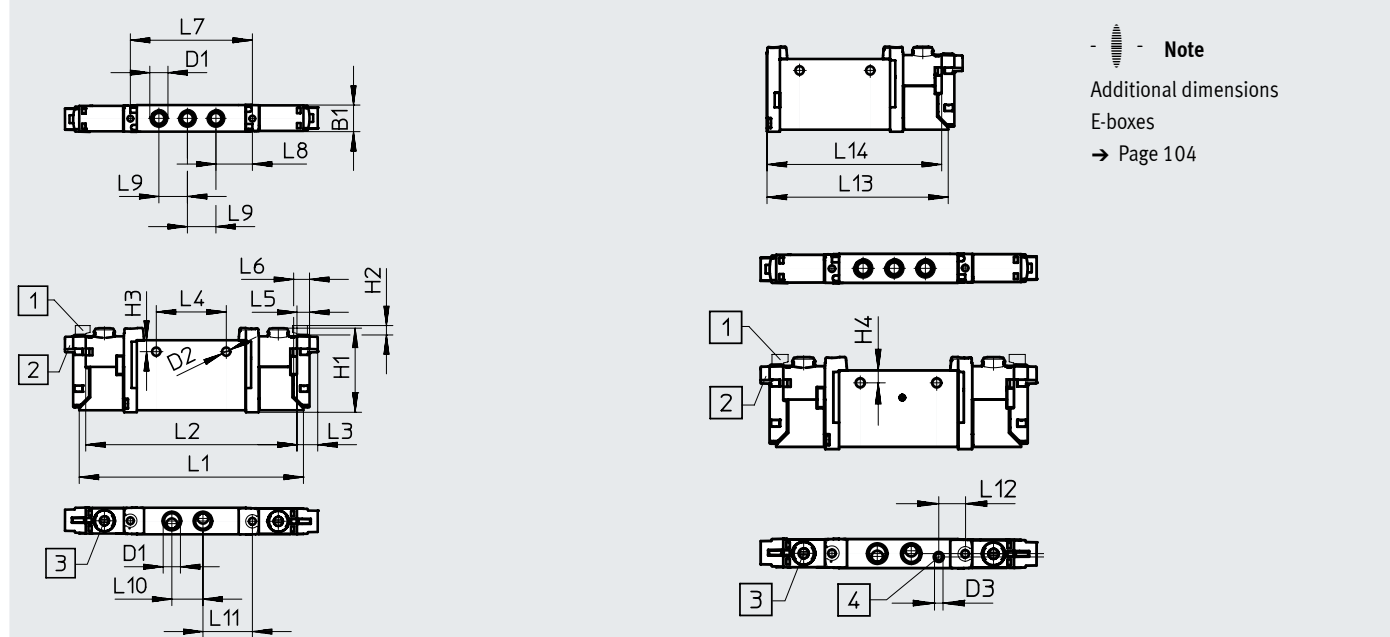

[1] Vertical electrical connection    [2] Horizontal electrical connection    [3] Manual override    [4] Port for external pilot air supply

Type	B1	B2	D1	D2	D3	H1	H2	H3	L1	L2	L3	L4
VUVG-L-10 ....-M7...	10.2	-	M7	3.2	M3	32.5	3.6	4.4	86.5	81.5	8	27
VUVG-S-10 ....-M7...												

Type	L5	L6	L7	L8	L9	L10	L11	L12	L13	L14
VUVG-L-10 ....-M7...	4.85	6.15	47	14	11	12	19	-	69.2	66.7
VUVG-S-10 ....-M7...										

Solenoid valves VUVG-L10 and VUVG-S10, in-line valves M7

Ordering data

★ Core product range

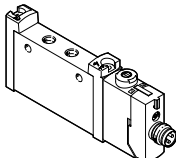
Ordering data		Description	Part no.	Type
<b>In-line valve M7, with E-box R8</b>				
	<b>5/3-way valve</b>			
	Internal pilot air supply	Mid-position closed, reset method: mechanical spring	★ 574223	VUVG-L10-P53C-T-M7-1R8L

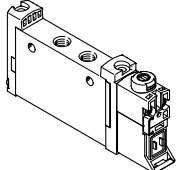
Ordering data		Description	Part no.	Type
<b>In-line valve M7, without E-box</b>				
	<b>2x 3/2-way valve</b>			
	Internal pilot air supply	Normally closed, reset method: pneumatic spring	566471	VUVG-L10-T32C-AT-M7-1P3
		Normally open, reset method: pneumatic spring	566472	VUVG-L10-T32U-AT-M7-1P3
		1x normally open, 1x normally closed, reset method: pneumatic spring	566473	VUVG-L10-T32H-AT-M7-1P3
		Normally closed, reset method: mechanical spring	574356	VUVG-L10-T32C-MT-M7-1P3
		Normally open, reset method: mechanical spring	574357	VUVG-L10-T32U-MT-M7-1P3
		1x normally open, 1x normally closed, reset method: mechanical spring	574358	VUVG-L10-T32H-MT-M7-1P3
	External pilot air supply	Normally closed, reset method: pneumatic spring	566479	VUVG-L10-T32C-AZT-M7-1P3
		Normally open, reset method: pneumatic spring	566480	VUVG-L10-T32U-AZT-M7-1P3
		1x normally open, 1x normally closed, reset method: pneumatic spring	566481	VUVG-L10-T32H-AZT-M7-1P3
		Normally closed, reset method: mechanical spring	574360	VUVG-L10-T32C-MZT-M7-1P3
		Normally open, reset method: mechanical spring	574361	VUVG-L10-T32U-MZT-M7-1P3
		Normally closed, reset method: mechanical spring	574362	VUVG-L10-T32H-MZT-M7-1P3

Festo core product range



Generally ready for dispatch from the factory within 24 hours

Generally ready for dispatch from the factory within 5 days

Ordering data

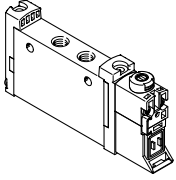
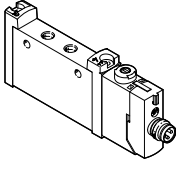
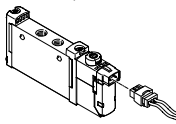
Ordering data	Description	Part no.	Type	
<b>In-line valve M7, without E-box</b>				
	<b>5/2-way valve, single solenoid</b>			
	Internal pilot air supply	Reset method: mechanical spring	574359	VUVG-L10-M52-MT-M7-1P3
		Reset method: pneumatic/mechanical spring	566474	VUVG-L10-M52-RT-M7-1P3
	External pilot air supply	Reset method: mechanical spring	574363	VUVG-L10-M52-MZT-M7-1P3
		Reset method: pneumatic/mechanical spring	566482	VUVG-L10-M52-RZT-M7-1P3
	<b>5/2-way valve, double solenoid</b>			
	Internal pilot air supply		566475	VUVG-L10-B52-T-M7-1P3
	External pilot air supply		566483	VUVG-L10-B52-ZT-M7-1P3
	<b>5/3-way valve</b>			
	Internal pilot air supply	Mid-position closed, reset method: mechanical spring	566476	VUVG-L10-P53C-T-M7-1P3
		Mid-position exhausted, reset method: mechanical spring	566477	VUVG-L10-P53E-T-M7-1P3
		Mid-position pressurised, reset method: mechanical spring	566478	VUVG-L10-P53U-T-M7-1P3
External pilot air supply	Mid-position closed, reset method: mechanical spring	566484	VUVG-L10-P53C-ZT-M7-1P3	
	Mid-position exhausted, reset method: mechanical spring	566485	VUVG-L10-P53E-ZT-M7-1P3	
	Mid-position pressurised, reset method: mechanical spring	566486	VUVG-L10-P53U-ZT-M7-1P3	
<b>In-line valve M7, with E-box R8</b>				
	<b>2x 3/2-way valve</b>			
	Internal pilot air supply	Normally closed, reset method: pneumatic spring	574218	VUVG-L10-T32C-AT-M7-1R8L
		Normally open, reset method: pneumatic spring	574219	VUVG-L10-T32U-AT-M7-1R8L
		1x normally open, 1x normally closed, reset method: pneumatic spring	574220	VUVG-L10-T32H-AT-M7-1R8L
		Normally closed, reset method: mechanical spring	8031480	VUVG-L10-T32C-MT-M7-1R8L
		Normally open, reset method: mechanical spring	8031481	VUVG-L10-T32U-MT-M7-1R8L
		1x normally open, 1x normally closed, reset method: mechanical spring	8031482	VUVG-L10-T32H-MT-M7-1R8L
	<b>5/2-way valve, single solenoid</b>			
	Internal pilot air supply	Reset method: pneumatic/mechanical spring	574221	VUVG-L10-M52-RT-M7-1R8L
		Reset method: mechanical spring	8031485	VUVG-L10-M52-MT-M7-1R8L
	<b>5/2-way valve, double solenoid</b>			
	Internal pilot air supply		574222	VUVG-L10-B52-T-M7-1R8L
<b>5/3-way valve</b>				
Internal pilot air supply	Mid-position exhausted, reset method: mechanical spring	574225	VUVG-L10-P53E-T-M7-1R8L	
	Mid-position pressurised, reset method: mechanical spring	574224	VUVG-L10-P53U-T-M7-1R8L	
<b>In-line valve M7, with E-box H2</b>				
	<b>5/2-way valve, single solenoid</b>			
	Internal pilot air supply	Reset method: pneumatic/mechanical spring	577333	VUVG-L10-M52-RT-M7-1H2L-W1
		Reset method: mechanical spring	578163	VUVG-L10-M52-MT-M7-1H2L-W1
	<b>5/2-way valve, double solenoid</b>			
Internal pilot air supply		577332	VUVG-L10-B52-T-M7-1H2L-W1	

Manifold assembly

In-line valves for manifold assembly



Dimensions

Download CAD data → [www.festo.com](http://www.festo.com)

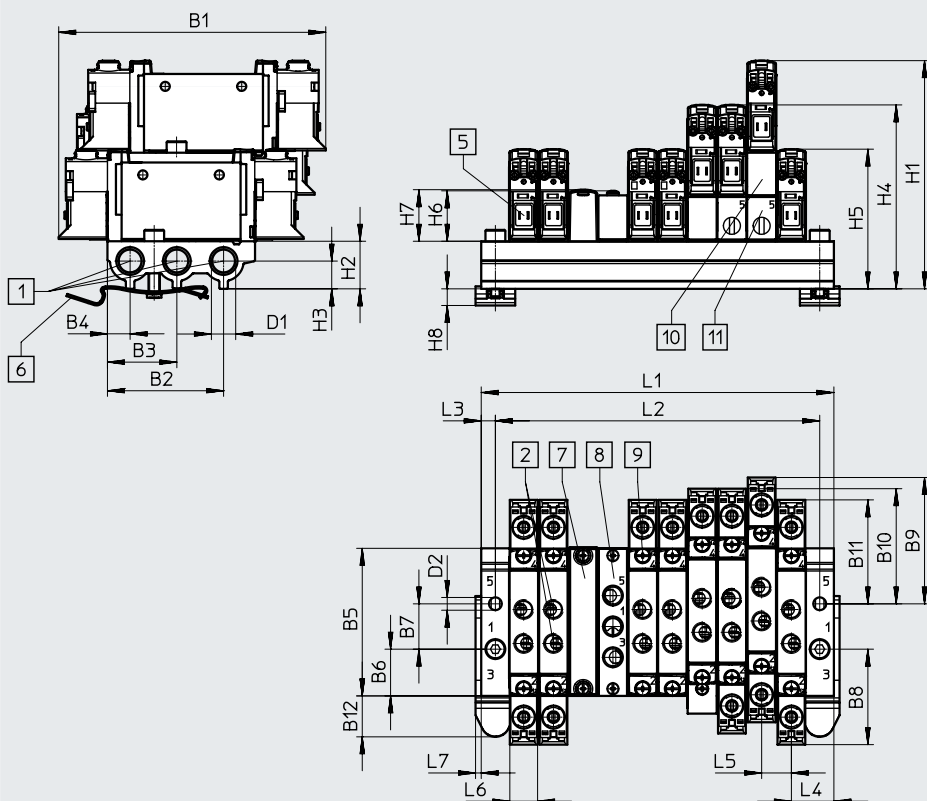

- - **Note**  
 Additional dimensions  
 E-boxes  
 → Page 104

- [1] Ports 1, 3 and 5: G1/8
- [2] Ports 1, 2, 3, 4 and 5 on the valve: M7 or M5
- [5] Electrical connection for E-boxes and accessories
- [6] H-rail mounting (two M4x20 screws are required for mounting)
- [7] Cover plate
- [8] Supply plate
- [9] Valves/cover plate mounting on manifold rail: M2 thread
- [10] Vertical pressure supply plate
- [11] Vertical pressure exhaust plate

Type	B1	B2	B3	B4	B5	B6	B7	B8	B9	B10	B11	B12
VABML-L1-10S-G18	94.3	41	24.5	8	52.1	16.5	16	33.7	44.6	40.7	36.7	14.4

Type	D1	D2	D5	H1	H2	H3	H4	H5	H6	H7	H8	L3	L4	L5	L6	L7
VABML-L1-10S-G18	G1/8	4.5	8	80.6	16.8	9.8	64.9	49.3	17.8	18	5.9	5	15	10.5	10.3	2

Ordering data

Valve positions	2	3	4	5	6	7	8	9	10	12	14	16	22
L1	40.5	51	61.5	72	82.5	93	103.5	114	124.5	145.5	166.5	187.5	250.5
L2	30.5	41	51.5	62	72.5	83	93.5	104	114.5	135.5	156.5	177.5	240.5
Weight of VABM [g]	63	78	93	108	123	138	153	168	183	213	243	273	363

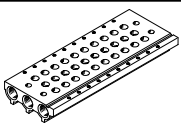
Technical data – Manifold rails							
	Port	CRC	Material <sup>2)</sup>	Operating pressure [bar]	Max. tightening torque for assembly [Nm]		
	1, 3, 5				Valve	H-rail	Wall
	G1/8	2 <sup>1)</sup>	Wrought aluminium alloy	-0.9 ... 10	0.45	1.5	3

- 1) Corrosion resistance class CRC 2 to Festo standard FN 940070  
Moderate corrosion stress. Indoor applications in which condensation can occur. External visible parts with primarily decorative surface requirements which are in direct contact with a normal industrial environment.
- 2) Note on materials: RoHS-compliant.

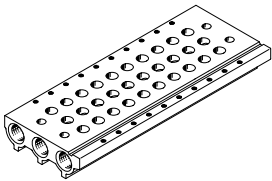
Ordering data – Manifold rail				
	Description	Part no.	Type	
<b>Manifold rail for in-line valve (manifold assembly)</b>				
	For size M5/M7	2 valve positions	★ 566558	VABM-L1-10S-G18-2
		3 valve positions	★ 566559	VABM-L1-10S-G18-3
		4 valve positions	★ 566560	VABM-L1-10S-G18-4
		5 valve positions	566561	VABM-L1-10S-G18-5
		6 valve positions	★ 566562	VABM-L1-10S-G18-6
		7 valve positions	566563	VABM-L1-10S-G18-7
		8 valve positions	★ 566564	VABM-L1-10S-G18-8
		9 valve positions	566565	VABM-L1-10S-G18-9
		10 valve positions	★ 566566	VABM-L1-10S-G18-10
		12 valve positions	566567	VABM-L1-10S-G18-12
		14 valve positions	566568	VABM-L1-10S-G18-14
		16 valve positions	566569	VABM-L1-10S-G18-16





Festo core product range

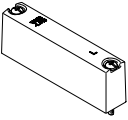

Generally ready for dispatch from the factory within 24 hours  
Generally ready for dispatch from the factory within 5 days

Solenoid valves VUVG-S10, in-line valves M5/M7

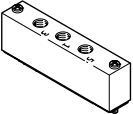
Ordering data

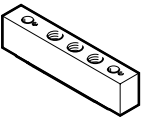
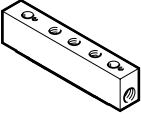
Ordering data – Accessories		Description	Part no.	Type
Cover plate <span style="float: right;">Data sheets → Internet: vabb</span>				
	For valve position on manifold rail, including screws and seal	★ 566462	VABB-L1-10-S	
Separator <span style="float: right;">Data sheets → Internet: vabd</span>				
	For creating pressure zones	569995	VABD-8-B	
Supply plate <span style="float: right;">Data sheets → Internet: vabf</span>				
	For valve position (in-line valves M5) on manifold rail, including screws and seal	569991	VABF-L1-10-P3A4-M5	
	For valve position (in-line valves M7) on manifold rail, including screws and seal	569992	VABF-L1-10-P3A4-M7	
Seals <span style="float: right;">Data sheets → Internet: vabd</span>				
	<b>In-line valves VUVG-LK</b>			
	For in-line valves M5	Delivery quantity: 10 sets (each with 2 screws and 1 seal)	★ 8043718	VABD-L1-10XK-S-M5-S
	For in-line valves M7		★ 8043719	VABD-L1-10XK-S-M7-S
	<b>In-line valves VUVG-L</b>			
For in-line valves M5	Delivery quantity: 10 sets (each with 2 screws and 1 seal)	★ 566672	VABD-L1-10X-S-M5	
For in-line valves M7		★ 566673	VABD-L1-10X-S-M7	
Vertical pressure exhaust plate				
	Pneumatic connection 1: M7	Terminal code CP	574592	VABF-L1-P3A3-M7
Vertical pressure exhaust plate				
	Pneumatic connection 3, 5: M7	Terminal code CR	574594	VABF-L1-P7A13-M7

Festo core product range





Generally ready for dispatch from the factory within 24 hours

Generally ready for dispatch from the factory within 5 days

Data sheet

Function  
2x 3/2C  
5/2-way, single solenoid  
5/2-way, double solenoid valve

-  - Size 14 mm
-  - Flow rate  
570 ... 660 l/min
-  - Voltage  
24 V DC

Circuit symbols → page 13



General technical data VUVG-LK			
Valve function	T32-A	M52-A	B52
Normal position	C <sup>1)</sup>	-	-
Stable position	Monostable		Bistable
Reset method: pneumatic spring	Yes	Yes	-
Design	Piston spool		
Sealing principle	Soft		
Actuation type	Electric		
Type of control	Piloted		
Pilot air supply	Internal		
Exhaust air function	Can be throttled		
Manual override	Non-detenting, detenting		
Type of mounting	Optionally via through-holes <sup>2)</sup> or on manifold rail		
Mounting position	Any		
Standard nominal flow rate	[l/min]	570	660
Switching time on/off	[ms]	13/20	14/24
Switching time changeover	[ms]	-	8
Size	[mm]	14	
Port	2, 4	G1/8	
Product weight	[g]	75	85
Corrosion resistance class CRC <sup>3)</sup>		2	

- 1) C=Normally closed
- 2) If several valves are to be screwed together via the through-holes to form a block, a minimum distance of 0.3 mm must be ensured by placing spacer discs between them.
- 3) Corrosion resistance class CRC 2 to Festo standard FN 940070  
Moderate corrosion stress. Indoor applications in which condensation can occur. External visible parts with primarily decorative surface requirements which are in direct contact with a normal industrial environment.

Safety data		
Max. positive test pulse with 0 signal	[µs]	1600
Max. negative test pulse with 1 signal	[µs]	3000
Shock resistance	Shock test with severity level 1 to FN 942017-5 and EN 60068-2-27	
Vibration resistance	Transport application test with severity level 1 to FN 942017-4 and EN 60068-2-6	

Solenoid valves VUVG-LK14, in-line valves G1/8

Data sheet

Operating and environmental conditions			
Valve function		T32-A <sup>1)</sup>	M52-A <sup>1)</sup>   B52
Operating medium		Compressed air to ISO 8573-1:2010 [7:4:4]	
Note on the operating/pilot medium		Lubricated operation possible (in which case lubricated operation will always be required)	
Operating pressure	[bar]	1.5 ... 7	2.5 ... 7   1.5 ... 7
Ambient temperature	[°C]	-5 ... +50	
Temperature of medium	[°C]	-5 ... +50	

1) Pneumatic spring

Electrical data	
Electrical connection	Via E-box → page 102
Operating voltage	[V DC] 24 ±10%
Power	[W] 0.7
Duty cycle	[%] 100
Degree of protection to EN 60529	IP40 (with plug socket), IP65 (with M8)
Signal status display	LED
Maximum switching frequency	[Hz] 2

Information on materials	
Housing	Wrought aluminium alloy
Seals	HNBR, NBR
Note on materials	RoHS-compliant Contains paint-wetting impairment substances

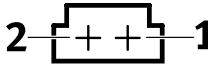
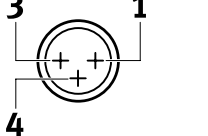
Pin allocation for E-box			
	Pin		Description
<b>Rectangular plug, connection pattern H</b>			
	1	+ or -	Protective circuit without holding current reduction
	2	+ or -	
<b>Round plug, M8, 3-pin</b>			
	1	Not used	Protective circuit without holding current reduction
	3	+ or -	
	4	+ or -	

Protective circuit without holding current reduction

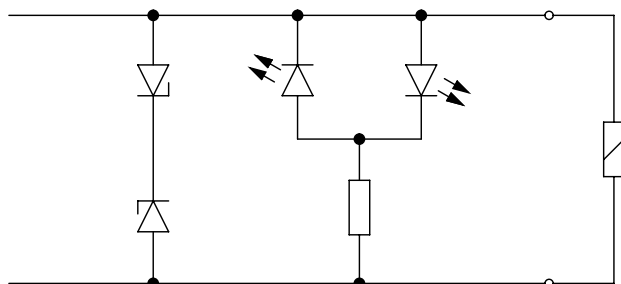

The solenoid coils are equipped with a protective circuit to arrest sparks and protect against polarity reversal.



Data sheet

Dimensions

Download CAD data → [www.festo.com](http://www.festo.com)

2x 3/2-way, 5/2-way valve, double solenoid

5/2-way valve, single solenoid

 **Note**  
Additional dimensions  
E-boxes  
→ Page 104

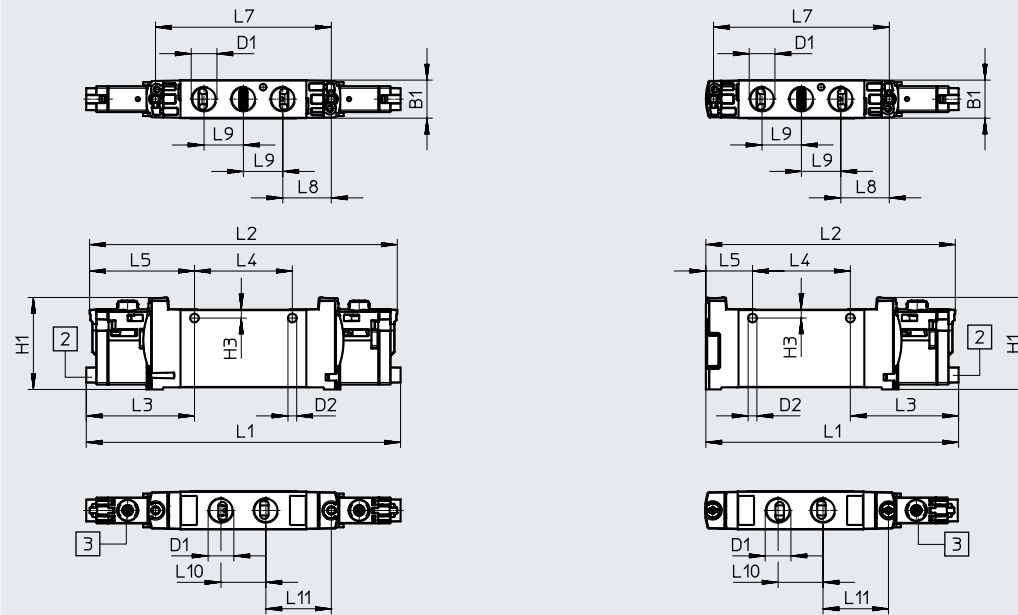

[2] Horizontal electrical connection    [3] Manual override

Type	B1	D1	D2	H1	H3	L1	L2	L3	L4	L5
VUVG-LK14-T32C...-G18...	14.4	G1/8	3.3	34.8	3.2	118.9	116.4	41	37	39.7
VUVG-LK14-B52...-G18...						95.6	94.4			17.7
VUVG-LK14-M52...-G18...										

Type	L7	L8	L9	L10	L11
VUVG-LK14-T32C...-G18...	66.5	18.4	14.9	17	24.8
VUVG-LK14-B52...-G18...					
VUVG-LK14-M52...-G18...					

Solenoid valves VUVG-LK14, in-line valves G1/8

Ordering data

★ Core product range

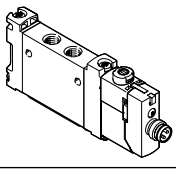
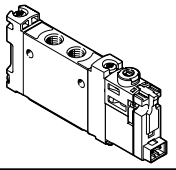
Ordering data		Description	Part no.	Type
<b>In-line valve G1/8, with E-box R8</b>				
	<b>2x 3/2-way valve</b>			
	Internal pilot air supply	Normally closed, reset method: pneumatic spring	★ 8042566	VUVG-LK14-T32C-AT-G18-1R8L-S
	<b>5/2-way valve, single solenoid</b>			
	Internal pilot air supply	Reset method: pneumatic spring	★ 8042567	VUVG-LK14-M52-AT-G18-1R8L-S
	<b>5/2-way valve, double solenoid</b>			
	Internal pilot air supply		★ 8042568	VUVG-LK14-B52-T-G18-1R8L-S
<b>In-line valve G1/8, with E-box H2</b>				
	<b>2x 3/2-way valve</b>			
	Internal pilot air supply	Normally closed, reset method: pneumatic spring	★ 8042562	VUVG-LK14-T32C-AT-G18-1H2L-S
	<b>5/2-way valve, single solenoid</b>			
	Internal pilot air supply	Reset method: pneumatic spring	★ 8042563	VUVG-LK14-M52-AT-G18-1H2L-S
	<b>5/2-way valve, double solenoid</b>			
	Internal pilot air supply		★ 8042564	VUVG-LK14-B52-T-G18-1H2L-S

Festo core product range





Generally ready for dispatch from the factory within 24 hours

Generally ready for dispatch from the factory within 5 days

Data sheet

Function  
 2x 3/2C, 2x 3/2U, 2x 3/2H  
 5/2-way, single solenoid  
 5/2-way, double solenoid valve  
 5/3C, 5/3U, 5/3E

Circuit symbols → page 13

-  - Size 14 mm
-  - Flow rate  
480 ... 780 l/min
-  - Voltage  
5, 12 and 24 V DC



General technical data VUVG-L												
Valve function		T32-A			T32-M			M52-A	B52	M52-M	P53	
Normal position		C <sup>1)</sup>	U <sup>2)</sup>	H <sup>4)</sup>	C <sup>1)</sup>	U <sup>2)</sup>	H <sup>4)</sup>	-	-	-	C <sup>1)</sup>	U <sup>2)</sup> E <sup>3)</sup>
Stable position		Monostable						Bistable		Monostable		
Reset method: pneumatic spring		Yes			No			Yes	-	No	-	
Reset method: mechanical spring		No			Yes			No	-	Yes	Yes	
Vacuum operation at port 1		No			Only with external pilot air supply							
Size [mm]		14										
Design		Piston spool										
Sealing principle		Soft										
Actuation type		Electric										
Type of control		Piloted										
Pilot air supply		Internal or external										
Exhaust air function		Can be throttled										
Manual override		Choice of non-detenting, covered, non-detenting/detenting or detenting										
Type of mounting		Optionally via through-holes <sup>5)</sup> or on manifold rail										
Mounting position		Any										
Nominal size [mm]		4.6			4.3			5.6	5.6	5.6	5.6	
Standard nominal flow rate [l/min]		560	600	590	550	500	500	780	780	780	650	560
Flow rate on manifold rail [l/min]		560	580		520	480	480	680	700	700	620	560
Switching time		On/off [ms]		8/23			15/11		14/22	-	13/40	12/40
		Changeover [ms]		-						8	-	20
Pneumatic connection		1, 2, 3, 4, 5		G1/8								
		12/14		M5								

- 1) C=Normally closed/mid-position closed
- 2) U=Normally open/mid-position pressurised
- 3) E=Mid-position exhausted
- 4) H=2x 3/2-way valve in one housing with 1x normally closed and 1x normally open
- 5) If several valves are to be screwed together via the through-holes to form a block, a minimum distance of 0.3 mm must be ensured by placing spacer discs between them.

## Solenoid valves VUVG-L14 and VUVG-S14, in-line valves G1/8

### Data sheet

General technical data VUVG-L						
Valve function	T32-A	T32-M	M52-A	B52	M52-M	P53
Product weight [g]	89	80	78	89	70	89
Certification	c UL us – Recognized (OL)					
	c CSA us (OL)					
	RCM					
CE marking (see declaration of conformity) <sup>1)</sup>	To EU EMC Directive					
Corrosion resistance class CRC <sup>2)</sup>	2					

1) For information about the area of use, see the EC declaration of conformity at: [www.festo.com/sp](http://www.festo.com/sp) → Certificates.

If the devices are subject to usage restrictions in residential, commercial or light-industrial environments, further measures for the reduction of the emitted interference may be necessary.

2) Corrosion resistance class CRC 2 to Festo standard FN 940070

Moderate corrosion stress. Indoor applications in which condensation can occur. External visible parts with primarily decorative surface requirements which are in direct contact with a normal industrial environment.

Operating and environmental conditions							
Valve function		T32-A <sup>1)</sup>	T32-M <sup>2)</sup>	M52-A <sup>1)</sup>	B52	M52-M <sup>2)</sup>	P53
Operating medium		Compressed air to ISO 8573-1:2010 [7:4:4]					
Operating pressure	Internal [bar]	1.5 ... 8	3 ... 8	2.5 ... 8	1.5 ... 8	3 ... 8	3 ... 8
	External [bar]	1.5... 10	-0.9... 10			-0.9... 8	-0.9... 10
Pilot pressure <sup>3)</sup>	[bar]	1.5 ... 8	3.5 ... 8	2.5 ... 8	1.5 ... 8	3 ... 8	3 ... 8
Ambient temperature	[°C]	-5 ... +50, with holding current reduction -5 ... +60					
Temperature of medium	[°C]	-5 ... +50, with holding current reduction -5 ... +60					

1) Pneumatic spring

2) Mechanical spring

3) Minimum pilot pressure 50% of the operating pressure

Electrical data	
Electrical connection	Via E-box → page 102
Operating voltage [V DC]	5, 12 and 24 ±10%
Power [W]	1, reduced to 0.35 with holding current reduction
Duty cycle [%]	100
Degree of protection to EN 60529	IP40 (with plug socket), IP65 (with M8)

Safety data	
Max. positive test pulse with 0 signal [µs]	700
Max. negative test pulse with 1 signal [µs]	900
Shock resistance	Shock test with severity level 2 to FN 942017-5 and EN 60068-2-27
Vibration resistance	Transport application test with severity level 2 to FN 942017-4 and EN 60068-2-6

Information on materials	
Housing	Wrought aluminium alloy
Seals	HNBR, NBR
Note on materials	RoHS-compliant

Data sheet

Dimensions VUVG

2x 3/2-way, 5/2-way and 5/3-way valve

Download CAD data → [www.festo.com](http://www.festo.com)

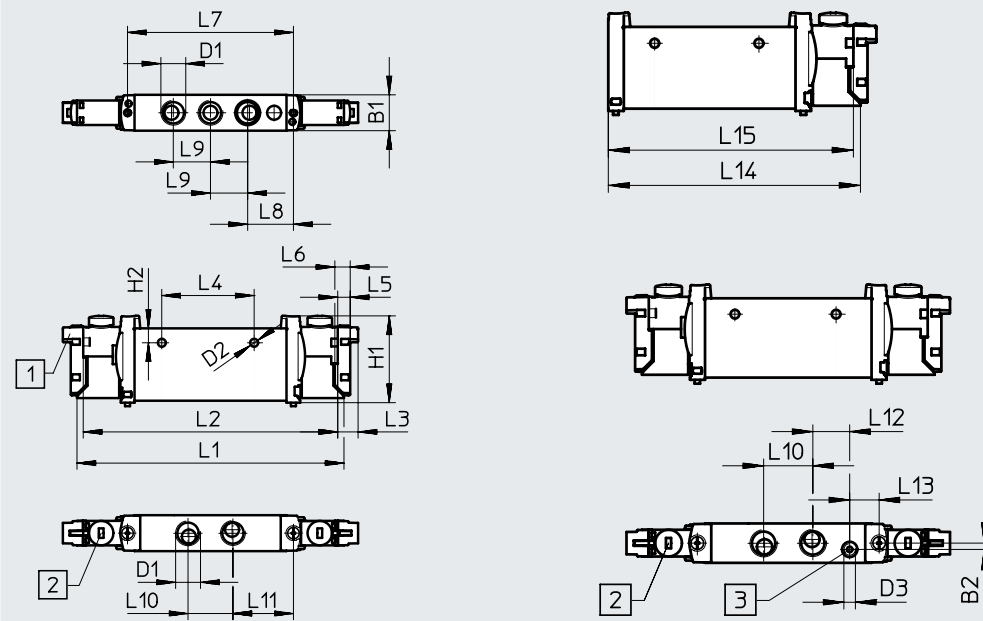

**Note**  
Additional dimensions  
E-boxes  
→ Page 104

[1] Horizontal electrical connection    [2] Manual override    [3] Port for external pilot air supply

Type	B1	B2	D1	D2 ∅	D3	H1	H2	L1	L2	L3	L4	L5	L6
VUVG-L14 ...-G18...	14.4	2.3	G1/8	3.2	-	34.8	5.8	107	102	8	37	4.85	6.2
VUVG-S14 ...-G18...													

Type	L7	L8	L9	L10	L11	L12	L13	L14	L15
VUVG-L14 ...-G18...	66.5	18.35	14.9	18	24.3	13.5	10.8	89.4	87
VUVG-S14 ...-G18...									

Solenoid valves VUVG-L14 and VUVG-S14, in-line valves G1/8

Ordering data

★ Core product range

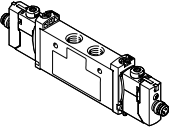
Ordering data		Description	Part no.	Type
<b>In-line valve G1/8, with E-box R8</b>				
	<b>5/3-way valve</b>			
	Internal pilot air supply	Mid-position closed, reset method: mechanical spring	★ 574231	VUVG-L14-P53C-T-G18-1R8L

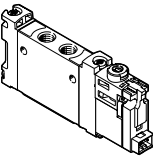
Ordering data		Description	Part no.	Type	
<b>In-line valve G1/8, without E-box</b>					
	<b>2x 3/2-way valve</b>				
	Internal pilot air supply	Normally closed, reset method: pneumatic spring	566496	VUVG-L14-T32-AT-G18-1P3	
		Normally open, reset method: pneumatic spring	566497	VUVG-L14-32U-AT-G18-1P3	
		1x normally open, 1x normally closed, reset method: pneumatic spring	566498	VUVG-L14-T32H-AT-G18-1P3	
		Normally closed, reset method: mechanical spring	574368	VUVG-L14-T32C-MT-G18-1P3	
		Normally open, reset method: mechanical spring	574369	VUVG-L14-T32U-MT-G18-1P3	
		1x normally open, 1x normally closed, reset method: mechanical spring	574370	VUVG-L14-T32H-MT-G18-1P3	
	External pilot air supply	Normally closed, reset method: pneumatic spring	566505	VUVG-L14-T32C-AZT-G18-1P3	
		Normally open, reset method: pneumatic spring	566506	VUVG-L14-T32U-AZT-G18-1P3	
		1x normally open, 1x normally closed, reset method: pneumatic spring	566507	VUVG-L14-T32H-AZT-G18-1P3	
		Normally closed, reset method: mechanical spring	574372	VUVG-L14-T32C-MZT-G18-1P3	
		Normally open, reset method: mechanical spring	574373	VUVG-L14-T32U-MZT-G18-1P3	
		Normally closed, reset method: mechanical spring	574374	VUVG-L14-T32H-MZT-G18-1P3	
	<b>5/2-way valve, single solenoid</b>				
	Internal pilot air supply	Reset method: pneumatic spring	566499	VUVG-L14-M52-AT-G18-1P3	
		Reset method: mechanical spring	574371	VUVG-L14-M52-MT-G18-1P3	
	External pilot air supply	Reset via pneumatic spring	566508	VUVG-L14-M52-AZT-G18-1P3	
		Reset method: mechanical spring	574375	VUVG-L14-M52-MZT-G18-1P3	
<b>5/2-way valve, double solenoid</b>					
Internal pilot air supply		566500	VUVG-L14-B52-T-G18-1P3		
External pilot air supply		566509	VUVG-L14-B52-ZT-G18-1P3		

Festo core product range



Generally ready for dispatch from the factory within 24 hours

Generally ready for dispatch from the factory within 5 days

Ordering data

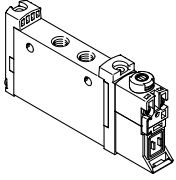
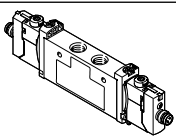
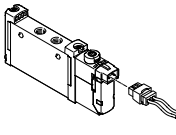
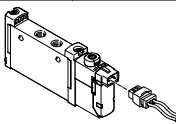
Ordering data	Description	Part no.	Type	
<b>In-line valve G1/8, without E-box</b>				
	<b>5/3-way valve</b>			
	Internal pilot air supply	Mid-position closed, reset method: mechanical spring	566501	VUVG-L14-P53C-T-G18-1P3
		Mid-position exhausted, reset method: mechanical spring	566502	VUVG-L14-P53E-T-G18-1P3
		Mid-position pressurised, reset method: mechanical spring	566503	VUVG-L14-P53U-T-G18-1P3
	External pilot air supply	Mid-position closed, reset method: mechanical spring	566510	VUVG-L14-P53C-ZT-G18-1P3
		Mid-position exhausted, reset method: mechanical spring	566511	VUVG-L14-P53E-ZT-G18-1P3
Mid-position pressurised, reset method: mechanical spring		566512	VUVG-L14-P53U-ZT-G18-1P3	
<b>In-line valve G1/8, with E-box R8</b>				
	<b>2x 3/2-way valve</b>			
	Internal pilot air supply	Normally closed, reset method: pneumatic spring	574226	VUVG-L14-T32C-AT-G18-1R8L
		Normally open, reset method: pneumatic spring	574227	VUVG-L14-T32U-AT-G18-1R8L
		1x normally open, 1x normally closed, reset method: pneumatic spring	574228	VUVG-L14-T32H-AT-G18-1R8L
		Normally closed, reset method: mechanical spring	8031504	VUVG-L14-T32C-MT-G18-1R8L
		Normally open, reset method: mechanical spring	8031505	VUVG-L14-T32U-MT-G18-1R8L
		1x normally open, 1x normally closed, reset method: mechanical spring	8031506	VUVG-L14-T32H-MT-G18-1R8L
	<b>5/2-way valve, single solenoid</b>			
	Internal pilot air supply	Reset method: pneumatic spring	574229	VUVG-L14-M52-AT-G18-1R8L
		Reset method: mechanical spring	8031508	VUVG-L14-M52-MT-G18-1R8L
	<b>5/2-way valve, double solenoid</b>			
	Internal pilot air supply		574230	VUVG-L14-B52-T-G18-1R8L
<b>5/3-way valve</b>				
Internal pilot air supply	Mid-position exhausted, reset method: mechanical spring	574233	VUVG-L14-P53E-T-G18-1R8L	
	Mid-position pressurised, reset method: mechanical spring	574232	VUVG-L14-P53U-T-G18-1R8L	
<b>In-line valve G1/8, with E-box H2</b>				
	<b>2x 3/2-way valve</b>			
	Internal pilot air supply	Normally closed, reset method: pneumatic spring	577321	VUVG-L14-T32C-AT-G18-1H2L-W1
	<b>5/2-way valve, single solenoid</b>			
	Internal pilot air supply	Reset method: pneumatic spring	576256	VUVG-L14-M52-AT-G18-1H2L-W1
		Reset method: mechanical spring	578164	VUVG-L14-M52-MT-G18-1H2L-W1
<b>5/2-way valve, double solenoid</b>				
Internal pilot air supply		577319	VUVG-L14-B52-T-G18-1H2L-W1	
<b>Semi in-line valve G1/8, with E-box H2</b>				
<b>5/2-way valve, single solenoid</b>				
	Internal pilot air supply	Reset method: pneumatic spring	577325	VUVG-S14-M52-AT-G18-1H2L-W1

Manifold assembly

In-line valves for manifold assembly



Dimensions

Download CAD data → [www.festo.com](http://www.festo.com)

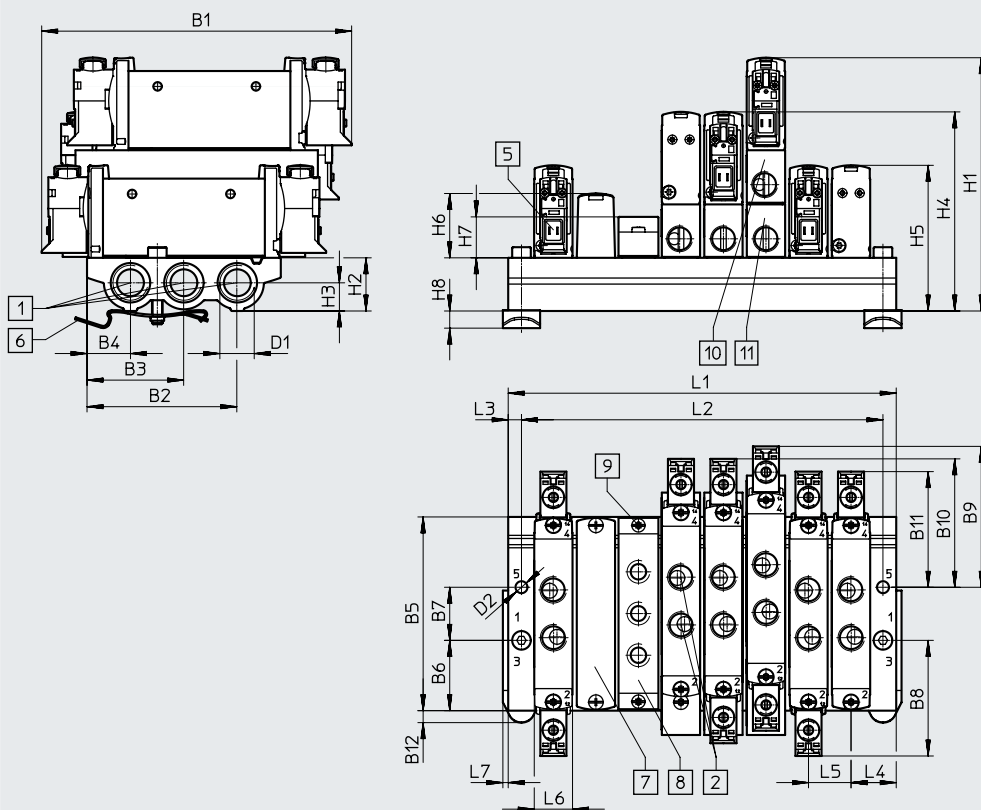

**Note**  
 Additional dimensions  
 E-boxes  
 → Page 104

- [1] Ports 1, 3 and 5: G1/4 (at both ends)
- [2] Ports 1, 2, 3, 4 and 5 on the valve: G1/8
- [5] Electrical connection for E-boxes and accessories
- [6] H-rail mounting (two M4x25 screws are required for mounting)
- [7] Cover plate
- [8] Supply plate, ports 1, 3 and 5: G1/8
- [9] Valves/cover plate mounting on manifold rail: M2.5 thread
- [10] Vertical pressure supply plate
- [11] Vertical pressure exhaust plate

Type	B1	B2	B3	B4	B5	B6	B7	B8	B9	B10	B11	B12	D1	D2
VABM-L1-14S-G14	116.6	56.6	36.5	16.4	72.9	26.5	20	43.5	53.1	48.3	43.5	4.5	G1/4	4.5

Type	H1	H2	H3	H4	H5	H6	H7	H8	L3	L4	L5	L6	L7
VABM-L1-14S-G14	95.3	20	10.6	74.9	54.8	23.9	15.4	6.5	5	17	16	14.5	2

Valve positions	2	3	4	5	6	7	8	9	10	12	14	16	22
L1	50	66	82	98	114	130	146	162	178	210	242	274	306
L2	40	56	72	88	104	120	136	152	168	200	232	264	296
Weight of VABM [g]	118	159	200	241	282	323	364	405	446	528	610	692	938

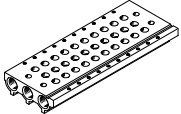

Ordering data

Technical data – Manifold rails							
	Port	CRC	Material <sup>2)</sup>	Operating pressure	Max. tightening torque for assembly [Nm]		Wall
	1, 3, 5			[bar]	Valve	H-rail	
	G1/4	2 <sup>1)</sup>	Wrought aluminium alloy	-0.9 ... 10	0.65	1.5	3

- 1) Corrosion resistance class CRC 2 to Festo standard FN 940070  
Moderate corrosion stress. Indoor applications in which condensation can occur. External visible parts with primarily decorative surface requirements which are in direct contact with a normal industrial environment.
- 2) Note on materials: RoHS-compliant.

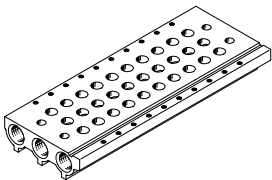
Ordering data – Manifold rail			
	Description	Part no.	Type
<b>Manifold rail for in-line valves (manifold assembly)</b>			
	For size G1/8	2 valve positions	★ 566618 VABM-L1-14S-G14-2
		3 valve positions	★ 566619 VABM-L1-14S-G14-3
		4 valve positions	★ 566620 VABM-L1-14S-G14-4
		5 valve positions	566621 VABM-L1-14S-G14-5
		6 valve positions	★ 566622 VABM-L1-14S-G14-6
		7 valve positions	566623 VABM-L1-14S-G14-7
		8 valve positions	★ 566624 VABM-L1-14S-G14-8
		9 valve positions	566625 VABM-L1-14S-G14-9
		10 valve positions	★ 566626 VABM-L1-14S-G14-10
		12 valve positions	566627 VABM-L1-14S-G14-12
		14 valve positions	566628 VABM-L1-14S-G14-14
		16 valve positions	566629 VABM-L1-14S-G14-16



Festo core product range



Generally ready for dispatch from the factory within 24 hours  
Generally ready for dispatch from the factory within 5 days

Solenoid valves VUVG-S14, in-line valves G1/8

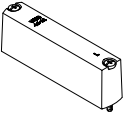
Ordering data

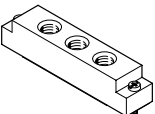
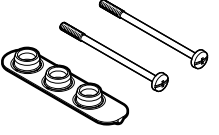
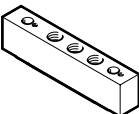
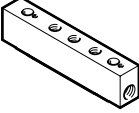
Ordering data – Accessories		Description	Part no.	Type
Data sheets → Internet: vabb				
	For valve position on manifold rail, including screws and seal		★ 569989	VABB-L1-14
Data sheets → Internet: vabd				
	For creating pressure zones		569996	VABD-10-B
Data sheets → Internet: vabf				
	For valve position on manifold rail, including screws and seal		569993	VABF-L1-14-P3A4-G18
Data sheets → Internet: vabd				
	<b>In-line valves VUVG-LK</b>			
	For G1/8 in-line valves	Delivery quantity: 10 sets (each with 2 screws and 1 seal)	★ 8043720	VABD-L1-14XK-S-G18-S
	<b>In-line valves VUVG-L</b>			
	For G1/8 in-line valves	Delivery quantity: 10 sets (each with 2 screws and 1 seal)	★ 566675	VABD-L1-14X-S-G18
Data sheets → Internet: vabd				
Vertical pressure exhaust plate				
	Pneumatic connection 1: G1/8	Terminal code CP	574593	VABF-L1-P3A3-G18
Vertical pressure exhaust plate				
	Pneumatic connection 3, 5: G1/8	Terminal code CR	574595	VABF-L1-P7A13-G18

Festo core product range



Generally ready for dispatch from the factory within 24 hours



Generally ready for dispatch from the factory within 5 days

Data sheet

Function

2x 3/2C, 2x 3/2U, 2x 3/2H  
 5/2-way, single solenoid  
 5/2-way, double solenoid valve  
 5/3C, 5/3U, 5/3E

Circuit symbols → page 13

-  - Size 18 mm
-  - Flow rate  
1000 ... 1380 l/min
-  - Voltage  
5, 12 and 24 V DC



General technical data VUVG-L												
Valve function	T32-A			T32-M			M52-R	B52	M52-M	P53		
Normal position	C <sup>1)</sup>	U <sup>2)</sup>	H <sup>4)</sup>	C <sup>1)</sup>	U <sup>2)</sup>	H <sup>4)</sup>	-	-	-	C <sup>1)</sup>	U <sup>2)</sup>	E <sup>3)</sup>
Stable position	Monostable							Bistable	Monostable			
Reset method: pneumatic spring	Yes			No			Yes <sup>5)</sup>	-	No	-		
Reset method: mechanical spring	No			Yes			Yes <sup>5)</sup>	-	Yes	Yes		
Vacuum operation at port 1	No			Only with external pilot air supply								
Size [mm]	18											
Design	Piston spool											
Sealing principle	Soft											
Actuation type	Electric											
Type of control	Piloted											
Pilot air supply	Internal/external											
Exhaust air function	Can be throttled											
Manual override	Choice of non-detenting, covered, non-detenting/detenting or detenting											
Type of mounting	Optionally via through-holes <sup>6)</sup> or on manifold rail											
Mounting position	Any											
Nominal size [mm]	5.7						6.9	7.3	6.9	6.5	6.3	
Standard nominal flow rate [l/min]	880	970	950	870	990	920	1300	1380	1300	1200	1000	910
Flow rate on manifold rail	780	980	820	780	960	820	1300	1370	1300	1180	1220	1050
Switching time	On/off [ms]	13/25			15/22			15/31	-	10/45	15/48	
	Changeover [ms]	-			-			-	11	-	29	
Pneumatic connection	1, 2, 3, 4, 5			G1/4								
	12/14			M5								
Product weight [g]	164			164			154	164	154	160		
Certification	c UL us – Recognized (OL)											
	c CSA us (OL)											
	RCM											
CE marking (see declaration of conformity) <sup>7)</sup>	To EU EMC Directive											
Corrosion resistance class CRC <sup>8)</sup>	2											

- 1) C=Normally closed/mid-position closed
- 2) U=Normally open/mid-position pressurised
- 3) E=Mid-position exhausted
- 4) H=2x 3/2-way valve in one housing with 1x normally closed and 1x normally open
- 5) Combined reset method
- 6) If several valves are to be screwed together via the through-holes to form a block, a minimum distance of 0.3 mm must be ensured by placing spacer discs between them.
- 7) For information about the area of use, see the EC declaration of conformity at: [www.festo.com/sp](http://www.festo.com/sp) → Certificates.  
If the devices are subject to usage restrictions in residential, commercial or light-industrial environments, further measures for the reduction of the emitted interference may be necessary.
- 8) Corrosion resistance class CRC 2 to Festo standard FN 940070  
Moderate corrosion stress. Indoor applications in which condensation can occur. External visible parts with primarily decorative surface requirements which are in direct contact with a normal industrial environment.

## Solenoid valves VUVG-L18 and VUVG-S18, in-line valves G1/4

### Data sheet

Operating and environmental conditions			T32-A <sup>1)</sup>	T32-M <sup>3)</sup>	M52-R <sup>2)</sup>	B52	M52-M <sup>3)</sup>	P53
Valve function								
Operating medium			Compressed air to ISO 8573-1:2010 [7:4:4]					
Note on the operating/pilot medium			Lubricated operation possible (in which case lubricated operation will always be required)					
Operating pressure	Internal	[bar]	1.5 ... 8	3 ... 8	2.5 ... 8	1.5 ... 8	3 ... 8	
	External	[bar]	1.5 ... 10	-0.9 ... 10				
Pilot pressure <sup>4)</sup>		[bar]	1.5 ... 8	2 ... 8	2.5 ... 8	1.5 ... 8	3 ... 8	
Ambient temperature	VUVG-...	[°C]	-5 ... +50, with holding current reduction -5 ... +60					
Temperature of medium	VUVG-...	[°C]	-5 ... +50, with holding current reduction -5 ... +60					

- 1) Pneumatic spring
- 2) Mixed, pneumatic/mechanical spring
- 3) Mechanical spring
- 4) Minimum pilot pressure 50% of operating pressure

Electrical data		
Electrical connection		Via E-box → page 102
Operating voltage	[V DC]	5, 12 and 24 ±10%
Power	[W]	1, reduced to 0.35 with holding current reduction
Duty cycle	[%]	100
Degree of protection to EN 60529		IP40 (with plug socket), IP65 (with M8)

Safety data		
Max. positive test pulse with 0 signal	[µs]	700
Max. negative test pulse with 1 signal	[µs]	900
Shock resistance		Shock test with severity level 2 to FN 942017-5 and EN 60068-2-27
Vibration resistance		Transport application test with severity level 2 to FN 942017-4 and EN 60068-2-6

Information on materials	
Housing	Wrought aluminium alloy
Seals	HNBR, NBR
Note on materials	RoHS-compliant

Data sheet

Dimensions VUVG-...

2x 3/2-way, 5/2-way and 5/3-way valve

Download CAD data → [www.festo.com](http://www.festo.com)

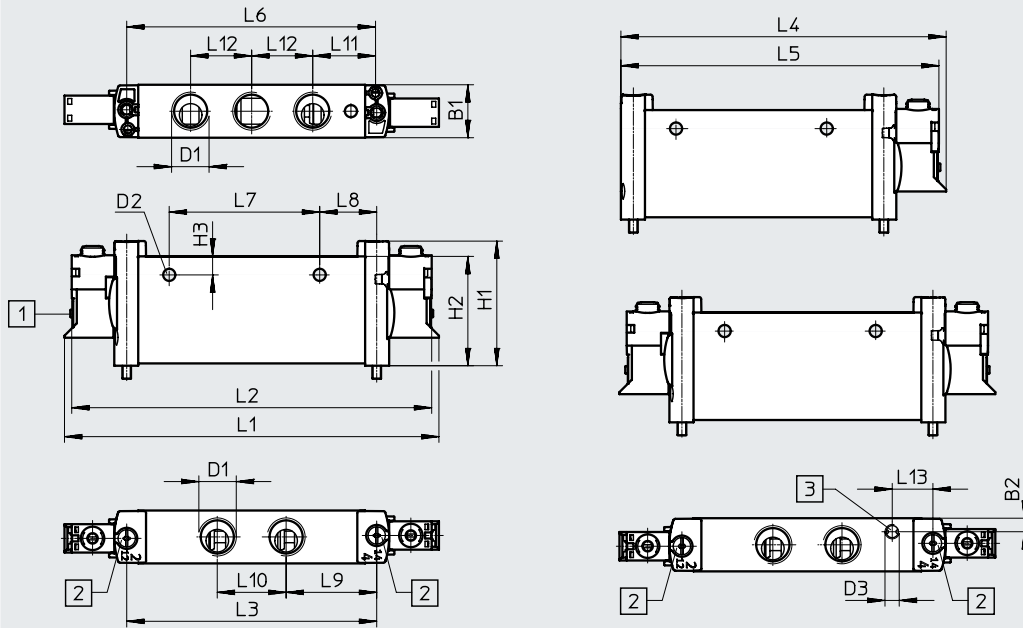

**Note**  
Additional dimensions  
E-boxes  
→ Page 104

- [1] Electrical connection without E-box
- [2] Retaining screw
- [3] Port for external pilot air supply

Type	B1	B2	D1	D2	D3	H1	H2	H3	L1	L2	L3	L4	L5
VUVG-L18-...	18.3	4.5	G1/4	∅ 4.2	M5	43.1	37.8	6.4	129.4	124.4	86.4	112.2	109.7
VUVG-S18-...													

Type	L6	L7	L8	L9	L10	L11	L12	L13
VUVG-L18-...	86	52	19.7	31.3	23.8	21.7	21.1	14
VUVG-S18-...								

Solenoid valves VUVG-L18 and VUVG-S18, in-line valves G1/4

Ordering data

★ Core product range

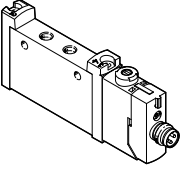
Ordering data		Description	Part no.	Type
<b>In-line valve G1/4, with E-box R8</b>				
	<b>2x 3/2-way valve</b>			
	Internal pilot air supply	Normally closed, reset method: pneumatic spring	★ 8031525	VUVG-L18-T32C-AT-G14-1R8L
	<b>5/2-way valve, single solenoid</b>			
	Internal pilot air supply	Reset method: pneumatic/mechanical spring	★ 8031531	VUVG-L18-M52-RT-G14-1R8L
		Reset method: mechanical spring	★ 8031532	VUVG-L18-M52-MT-G14-1R8L
	<b>5/3-way valve</b>			
Internal pilot air supply	Mid-position closed, reset method: mechanical spring	★ 8031534	VUVG-L18-P53C-T-G14-1R8L	

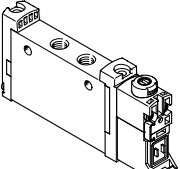
Ordering data		Description	Part no.	Type
<b>In-line valve G1/4, without E-box</b>				
	<b>2x 3/2-way valve</b>			
	Internal pilot air supply	Normally closed, reset method: pneumatic spring	574422	VUVG-L18-T32C-AT-G14-1P3
		Normally open, reset method: pneumatic spring	574423	VUVG-L18-T32U-AT-G14-1P3
		1x normally open, 1x normally closed, reset method: pneumatic spring	574424	VUVG-L18-T32H-AT-G14-1P3
		Normally closed, reset method: mechanical spring	574425	VUVG-L18-T32C-MT-G14-1P3
		Normally open, reset method: mechanical spring	574426	VUVG-L18-T32U-MT-G14-1P3
		1x normally open, 1x normally closed, reset method: mechanical spring	574427	VUVG-L18-T32H-MT-G14-1P3
	External pilot air supply	Normally closed, reset method: mechanical spring	574434	VUVG-L18-T32C-MZT-G14-1P3
		Normally open, reset method: mechanical spring	574435	VUVG-L18-T32U-MZT-G14-1P3
		1x normally open, 1x normally closed, reset method: mechanical spring	574436	VUVG-L18-T32H-MZT-G14-1P3
	<b>5/2-way valve, single solenoid</b>			
	Internal pilot air supply	Reset method: pneumatic/mechanical spring	574428	VUVG-L18-M52-RT-G14-1P3
		Reset method: mechanical spring	574429	VUVG-L18-M52-MT-G14-1P3
	External pilot air supply	Reset method: mechanical spring	574438	VUVG-L18-M52-MZT-G14-1P3
		Reset method: pneumatic/mechanical spring	574437	VUVG-L18-M52-RZT-G14-1P3
	<b>5/2-way valve, double solenoid</b>			
Internal pilot air supply		574430	VUVG-L18-B52-T-G14-1P3	
External pilot air supply		574439	VUVG-L18-B52-ZT-G14-1P3	

Festo core product range



Generally ready for dispatch from the factory within 24 hours

Generally ready for dispatch from the factory within 5 days

Ordering data

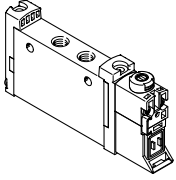
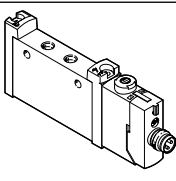
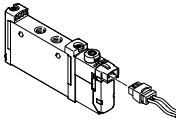
Ordering data	Description	Part no.	Type	
<b>In-line valve G1/4, without E-box</b>				
	<b>5/3-way valve</b>			
	Internal pilot air supply	Mid-position closed, reset method: mechanical spring	574431	VUVG-L18-P53C-T-G14-1P3
		Mid-position exhausted, reset method: mechanical spring	574432	VUVG-L18-P53E-T-G14-1P3
		Mid-position pressurised, reset method: mechanical spring	574433	VUVG-L18-P53U-T-G14-1P3
	External pilot air supply	Mid-position closed, reset method: mechanical spring	574440	VUVG-L18-P53C-ZT-G14-1P3
		Mid-position exhausted, reset method: mechanical spring	574441	VUVG-L18-P53E-ZT-G14-1P3
Mid-position pressurised, reset method: mechanical spring		574442	VUVG-L18-P53U-ZT-G14-1P3	
<b>In-line valve G1/4, with E-box R8</b>				
	<b>2x 3/2-way valve</b>			
	Internal pilot air supply	Normally open, reset method: pneumatic spring	8031526	VUVG-L18-T32U-AT-G14-1R8L
		1x normally open, 1x normally closed, reset method: pneumatic spring	8031527	VUVG-L18-T32H-AT-G14-1R8L
		Normally closed, reset method: mechanical spring	8031528	VUVG-L18-T32C-MT-G14-1R8L
		Normally open, reset method: mechanical spring	8031529	VUVG-L18-T32U-MT-G14-1R8L
		1x normally open, 1x normally closed, reset method: mechanical spring	8031530	VUVG-L18-T32H-MT-G14-1R8L
	<b>5/2-way valve, double solenoid</b>			
	Internal pilot air supply		8031533	VUVG-L18-B52-T-G14-1R8L
	<b>5/3-way valve</b>			
	Internal pilot air supply	Mid-position exhausted, reset method: mechanical spring	8031535	VUVG-L18-P53E-T-G14-1R8L
Mid-position pressurised, reset method: mechanical spring		8031536	VUVG-L18-P53U-T-G14-1R8L	
<b>In-line valve G1/4, with E-box H2</b>				
	<b>5/2-way valve, single solenoid</b>			
Internal pilot air supply	Reset method: pneumatic/mechanical spring	578823	VUVG-L18-M52-RT-G14-1H2L-W1	

Manifold assembly

In-line valves for manifold assembly



Dimensions

Download CAD data → [www.festo.com](http://www.festo.com)

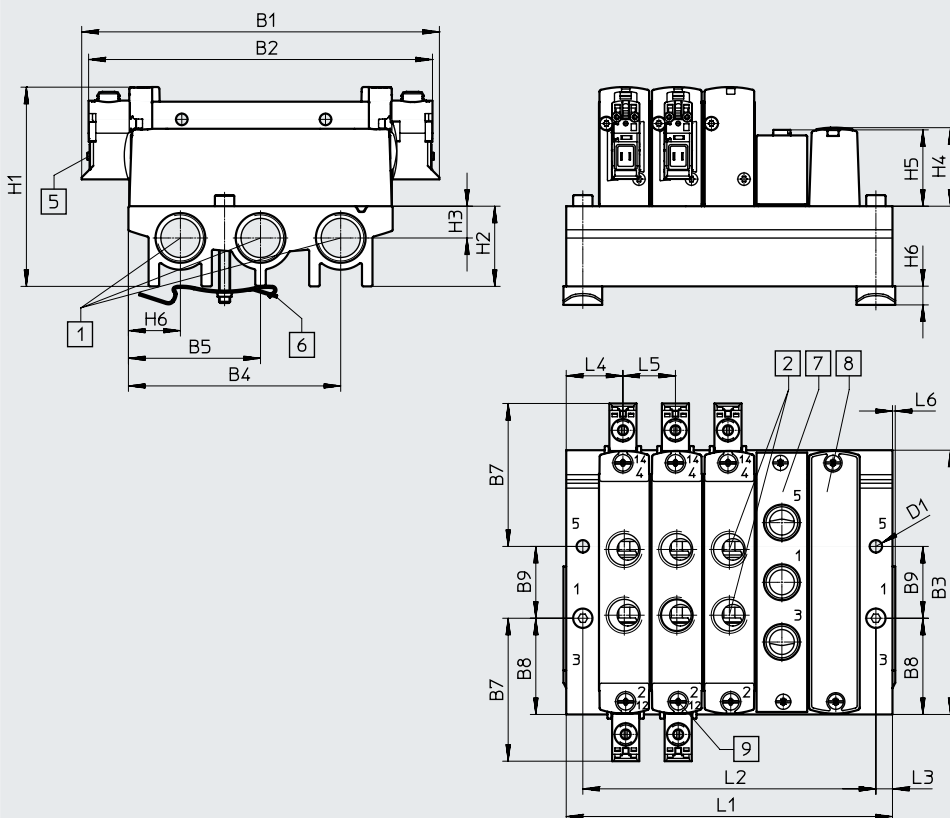

- - **Note**  
Additional dimensions  
E-boxes  
→ Page 104

- [1] Ports 1, 3 and 5: G3/8 (at both ends)
- [2] Ports 2 and 4: G1/4
- [5] Electrical connection for E-boxes and accessories
- [6] H-rail mounting (two M4x35 screws are required for mounting)
- [7] Cover plate
- [8] Supply plate, ports 1, 3 and 5: G1/4
- [9] Valves/cover plate mounting on manifold rail: M3 thread

Type	B1	B2	B3	B4	B5	B6	B7	B8	B9	D1
VABM-L1-18S-G38	129.4	124.4	95.6	76.8	47.8	18.8	51.7	34.8	26	4.5

Type	H1	H2	H3	H4	H5	H6	L3	L4	L5	L6
VABM-L1-18S-G38	72.1	29	11.5	28.4	27.6	6.5	6	20.5	19	1

Valve positions	2	3	4	5	6	7	8	9	10	12	14	16
L1	61	80	99	118	137	156	175	194	213	251	289	327
L2	49	68	87	106	125	144	163	182	201	239	277	315
Weight of VABM [g]	118	159	200	241	282	323	364	405	446	528	610	692



Ordering data

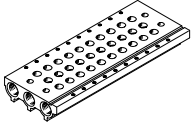

Technical data – Manifold rails							
	Port	CRC	Material <sup>2)</sup>	Operating pressure [bar]	Max. tightening torque for assembly [Nm]		
	1, 3, 5				Valve	H-rail	Wall
	G3/8	2 <sup>1)</sup>	Wrought aluminium alloy	-0.9 ... 10	1.18	1.5	3

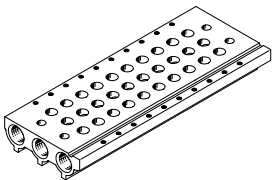
- 1) Corrosion resistance class CRC 2 to Festo standard FN 940070  
Moderate corrosion stress. Indoor applications in which condensation can occur. External visible parts with primarily decorative surface requirements which are in direct contact with a normal industrial environment.
- 2) Note on materials: RoHS-compliant.

Ordering data – Manifold rail				
	Description		Part no.	Type
	For size G1/4	2 valve positions	★ 574455	VABM-L1-18S-G38-2
		3 valve positions	★ 574456	VABM-L1-18S-G38-3
		4 valve positions	★ 574457	VABM-L1-18S-G38-4
		5 valve positions	574458	VABM-L1-18S-G38-5
		6 valve positions	★ 574459	VABM-L1-18S-G38-6
		7 valve positions	574460	VABM-L1-18S-G38-7
		8 valve positions	★ 574461	VABM-L1-18S-G38-8
		9 valve positions	574462	VABM-L1-18S-G38-9
		10 valve positions	★ 574463	VABM-L1-18S-G38-10
		12 valve positions	574464	VABM-L1-18S-G38-12
		14 valve positions	574465	VABM-L1-18S-G38-14
		16 valve positions	574466	VABM-L1-18S-G38-16

Solenoid valves VUVG-S18, in-line valves G1/4

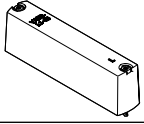
Ordering data

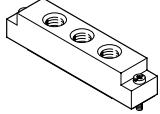
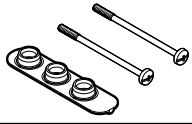
Ordering data – Accessories		Description	Part no.	Type
Data sheets → Internet: vabb				
	For valve position on manifold rail, including screws and seal	★ 574482	VABB-L1-18	
Data sheets → Internet: vabd				
	For creating pressure zones	574483	VABD-14-B	
Data sheets → Internet: vabf				
	For valve position on manifold rail, including screws and seal	574481	VABF-L1-18-P3A4-G14	
Data sheets → Internet: vabd				
	For G1/4 in-line valves	Delivery quantity: 10 sets (each with 2 screws and 1 seal)	★ 574479	VABD-L1-18X-S-G14

 **Note**  
 Connect supply plate at port 1 with compressed air. Reverse operation (pressure at port 3, 5) is not permissible.

Festo core product range





Generally ready for dispatch from the factory within 24 hours  
 Generally ready for dispatch from the factory within 5 days

Data sheet

Function

5/2-way, single solenoid  
5/2-way, double solenoid valve  
5/3C, 5/3U, 5/3E

Circuit symbols → page 13

-  - Size 10 mm
-  - Flow rate  
90 ... 100 l/min
-  - Voltage  
5, 12 and 24 V DC



General technical data VUVG-B						
Valve function		M52-R	B52	M52-M	P53	
Normal position		–	–	–	C <sup>1)</sup>	U <sup>2)</sup> E <sup>3)</sup>
Stable position		Monostable	Bistable	Monostable	Monostable	
Reset method: pneumatic spring		Yes <sup>4)</sup>	–	No	–	
Reset method: mechanical spring		Yes <sup>4)</sup>	–	Yes	Yes	
Vacuum operation at port 1		Only with external pilot air supply				
Design		Piston spool				
Sealing principle		Soft				
Actuation type		Electric				
Type of control		Piloted				
Pilot air supply		External, internal; can be selected via sub-base				
Exhaust air function		Can be throttled				
Manual override		Choice of non-detenting, covered, non-detenting/detenting or detenting				
Type of mounting		On manifold rail				
Mounting position		Any				
Nominal size	[mm]	2		1.4	2	
Standard nominal flow rate	[l/min]	100		80	90	
Flow rate on manifold rail M3	[l/min]	100		80	90	
Switching time on/off	[ms]	7/15	–	7/21	8/25	
Switching time changeover	[ms]	–	5	–	14	
Size	[mm]	10				
Port	1, 3, 5	M7 in manifold rail				
	2, 4	M5 in manifold rail				
	12/14, 82/84	M5 in manifold rail				
Product weight	[g]	38	49	37	49	
Certification		c UL us – Recognized (OL)				
		c CSA us (OL)				
		RCM				
CE marking (see declaration of conformity) <sup>5)</sup>		To EU EMC Directive				
Corrosion resistance class CRC <sup>6)</sup>		2				

- 1) C=Normally closed/mid-position closed
- 2) U=Normally open/mid-position pressurised
- 3) E=Mid-position exhausted
- 4) Combined reset method
- 5) For information about the area of use, see the EC declaration of conformity at: [www.festo.com/sp](http://www.festo.com/sp) → Certificates.  
If the devices are subject to usage restrictions in residential, commercial or light-industrial environments, further measures for the reduction of the emitted interference may be necessary.
- 6) Corrosion resistance class CRC 2 to Festo standard FN 940070  
Moderate corrosion stress. Indoor applications in which condensation can occur. External visible parts with primarily decorative surface requirements which are in direct contact with a normal industrial environment.

**Data sheet**

Operating and environmental conditions			M52-R <sup>1)</sup>	B52	M52-M <sup>2)</sup>	P53
Valve function			Compressed air to ISO 8573-1:2010 [7:4:4]			
Operating pressure	Internal	[bar]	2.5 ... 8	1.5 ... 8	3 ... 8	
	External	[bar]	-0.9 ... 10		-0.9 ... 8	-0.9 ... 10
Pilot pressure <sup>3)</sup>		[bar]	2.5 ... 8	1.5 ... 8	2 ... 8	3 ... 8
Ambient temperature		[°C]	-5 ... +50, with holding current reduction -5 ... +60			
Temperature of medium		[°C]	-5 ... +50, with holding current reduction -5 ... +60			

- 1) Mixed, pneumatic/mechanical spring
- 2) Mechanical spring
- 3) Minimum pilot pressure 50% of the operating pressure

Electrical data	
Electrical connection	Via E-box → page 102
Operating voltage	[V DC] 5, 12 and 24 ±10%
Power	[W] 1, reduced to 0.35 with holding current reduction
Duty cycle	[%] 100
Degree of protection to EN 60529	IP40 (with plug socket), IP65 (with M8)

Information on materials	
Housing	Wrought aluminium alloy
Seals	HNBR, NBR
Note on materials	RoHS-compliant

**Dimensions**

Download CAD data → [www.festo.com](http://www.festo.com)

5/2-way and 5/3-way valve

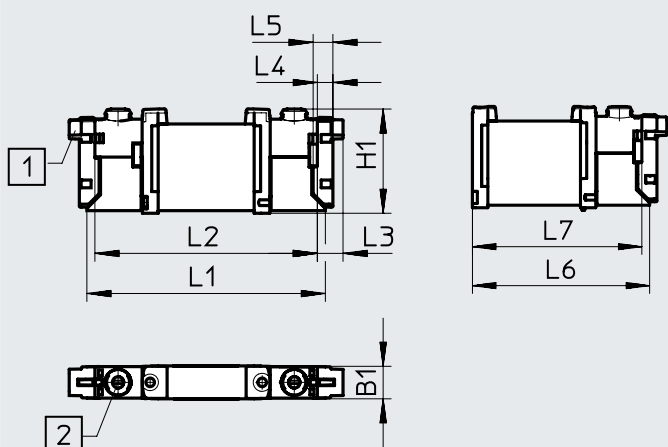

**Note**  
Additional dimensions  
E-boxes  
→ Page 104

[1] Vertical electrical connection      [2] Manual override

Type	B1	H1	L1	L2	L3	L4	L5	L6	L7
VUVG-B10A-...-F...	10.2	32.5	73.9	68.9	8	4.85	6.15	56.9	54.4

### Ordering data

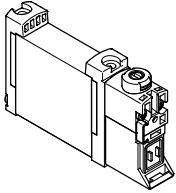
Ordering data	Description	Part no.	Type	
<b>Sub-base valve M3, without E-box</b>				
	<b>5/2-way valve, single solenoid</b>			
	External pilot air supply	Reset method: pneumatic/mechanical spring	<b>566448</b>	<b>VUVG-B10A-M52-RZT-F-1P3</b>
		Reset method: mechanical spring	<b>574347</b>	<b>VUVG-B10A-M52-MZT-F-1P3</b>
	<b>5/2-way valve, double solenoid</b>			
	External pilot air supply		<b>566449</b>	<b>VUVG-B10A-B52-ZT-F-1P3</b>
	<b>5/3-way valve</b>			
	External pilot air supply	Mid-position closed, reset method: mechanical spring	<b>566450</b>	<b>VUVG-B10A-P53C-ZT-F-1P3</b>
		Mid-position exhausted, reset method: mechanical spring	<b>566451</b>	<b>VUVG-B10A-P53E-ZT-F-1P3</b>
		Mid-position pressurised, reset method: mechanical spring	<b>566452</b>	<b>VUVG-B10A-P53U-ZT-F-1P3</b>

Manifold assembly

Sub-base valve for manifold assembly  
Connection M5



Dimensions

Download CAD data → [www.festo.com](http://www.festo.com)

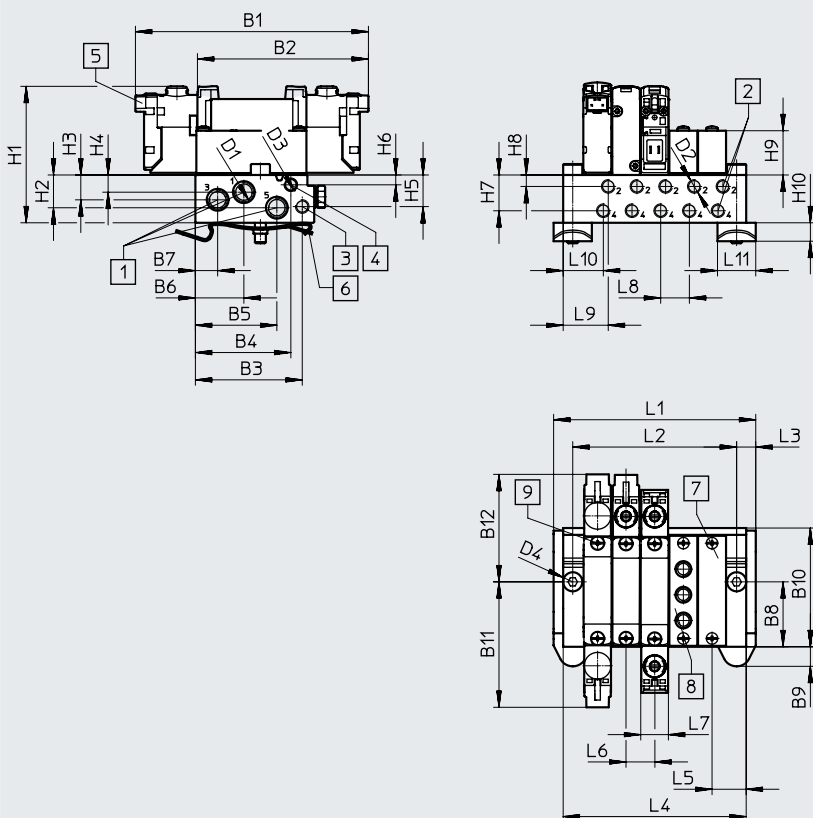

-  - **Note**  
Additional dimensions  
E-boxes  
→ Page 104

- [1] Ports 1, 3 and 5: M7 (at both ends)
- [2] Ports 2, 4: M5
- [3] Ports 12, 14: M5
- [4] Ports 82, 84: M5
- [5] Electrical connection for E-boxes and accessories
- [6] H-rail mounting (two M4x25 screws are required for mounting)
- [7] Cover plate
- [8] Supply plate, ports 1, 3 and 5: M5
- [9] Valves/cover plate mounting on manifold rail: M2 thread

Type	B1	B2	B3	B4	B5	B6	B7	B8	B9	B10	B11	B12
VABM-L1-10AW-M7	84.9	62.4	39.1	35	29.8	17.8	8.2	24	7.2	43.5	45.8	39.2

Type	D1	D2	D3	D4	D5	H1	H2	H3	H4	H5	H6
VABM-L1-10AW-M7	M 7	M 5	M 5	Ø4.5	Ø4	53.1	12	9.1	6.3	11.6	3.6

Type	H7	H8	H9	H10	H15	L3	L5	L6	L7	L8	L9	L10	L11
VABM-L1-10AW-M7	13.1	4.2	16.2	6.8	1.9	7.5	12.5	10.5	10.2	10.5	17	15.2	14

**Ordering data**

Valve positions	2	3	4	5	6	7	8	9	10	12	14	16
L1	43.5	54	64.5	75	85.5	97	107.5	117	127.5	148.5	169.5	190.5
L2	28.5	39	49.5	60	70.5	81	91.5	102	112.5	133.5	154.5	175.5
L4	36.5	47	57.5	68	78.5	89	99.5	110	120.5	141.5	162.5	183.5
Weight of VABM [g]	60	78	96	114	132	150	168	186	204	240	276	312

**Technical data – Manifold rails<sup>1)</sup>**

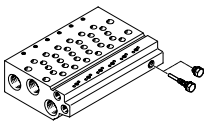
	Port			CRC	Material <sup>3)</sup>	Operating pressure [bar]	Max. tightening torque for assembly [Nm]		
	2, 4	1, 3, 5	12/14, 82/84				Valve	H-rail	Wall
	M5	M7	M5	2 <sup>2)</sup>	Wrought aluminium alloy	-0.9 ... 10	0.45	1.5	1.5



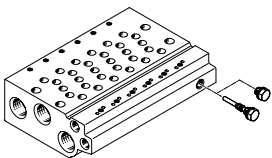

- 1) Blanking plugs are included with the manifold rail.
- 2) Corrosion resistance class CRC 2 to Festo standard FN 940070  
Moderate corrosion stress. Indoor applications in which condensation can occur. External visible parts with primarily decorative surface requirements which are in direct contact with a normal industrial environment.
- 3) Note on materials: RoHS-compliant.

**Ordering data – Manifold rails**

	Description	Part no.	Type
<b>Manifold rail for sub-base valve M3</b>			
	For size B10A (M3)	2 valve positions	566546 VABM-L1-10AW-M7-2
		3 valve positions	566547 VABM-L1-10AW-M7-3
		4 valve positions	566548 VABM-L1-10AW-M7-4
		5 valve positions	566549 VABM-L1-10AW-M7-5
		6 valve positions	566550 VABM-L1-10AW-M7-6
		7 valve positions	566551 VABM-L1-10AW-M7-7
		8 valve positions	566552 VABM-L1-10AW-M7-8
		9 valve positions	566553 VABM-L1-10AW-M7-9
		10 valve positions	566554 VABM-L1-10AW-M7-10
		12 valve positions	566555 VABM-L1-10AW-M7-12
		14 valve positions	566556 VABM-L1-10AW-M7-14
		16 valve positions	566557 VABM-L1-10AW-M7-16

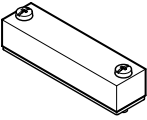
Solenoid valves VUVG-B10A, sub-base valves M3

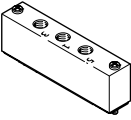

Ordering data

Ordering data – Accessories		Description	Part no.	Type
Cover plate				Data sheets → Internet: vabb
	For valve position on manifold rail, including screws and seal		<b>569986</b>	<b>VABB-L1-10A</b>
Separator				Data sheets → Internet: vabd
	For creating pressure zones		<b>570872</b>	<b>VABD-4.2-B</b>
Supply plate				Data sheets → Internet: vabf
	For valve position on manifold rail, including screws and seal		<b>569990</b>	<b>VABF-L1-10A-P3A4-M5</b>
Seals				Data sheets → Internet: vabd
	For sub-base valve M3	Delivery quantity: 10 sets (each with 2 screws and 1 seal)	<b>566671</b>	<b>VABD-L1-10AB-S-M3</b>



Data sheet

Function  
2x 3/2C  
5/2-way, single solenoid  
5/2-way, double solenoid valve

-  - Size 10 mm
-  - Flow rate  
160 l/min
-  - Voltage  
24 V DC

Circuit symbols → page 13

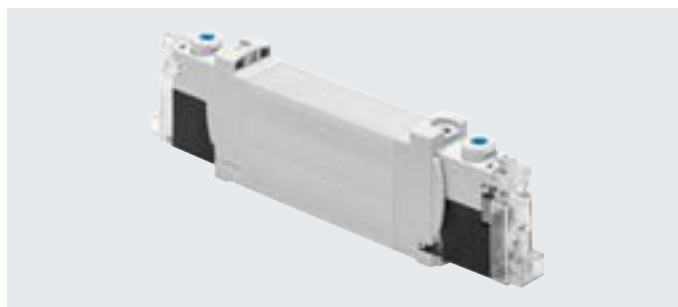

General technical data VUVG-BK				
Valve function		T32-A	M52-A	B52
Normal position		C <sup>1)</sup>	-	-
Stable position		Monostable		Bistable
Reset method: pneumatic spring		Yes	Yes	-
Design		Piston spool		
Sealing principle		Soft		
Actuation type		Electric		
Type of control		Piloted		
Pilot air supply		Internal		
Exhaust air function		Can be throttled		
Manual override		Non-detenting, detenting		
Type of mounting		On manifold rail		
Mounting position		Any		
Standard nominal flow rate	[l/min]	160	160	160
Switching time on/off	[ms]	12/14	14/17	-
Switching time changeover	[ms]	-	-	7
Size	[mm]	10		
Port	2, 4	M5/M7 in manifold rail		
Product weight	[g]	55	45	57
Corrosion resistance class CRC <sup>2)</sup>		2		

1) C=Normally closed

2) Corrosion resistance class CRC 2 to Festo standard FN 940070

Moderate corrosion stress. Indoor applications in which condensation can occur. External visible parts with primarily decorative surface requirements which are in direct contact with a normal industrial environment.

Safety data		
Max. positive test pulse with 0 signal	[µs]	1600
Max. negative test pulse with 1 signal	[µs]	3000
Shock resistance		Shock test with severity level 1 to FN 942017-5 and EN 60068-2-27
Vibration resistance		Transport application test with severity level 1 to FN 942017-4 and EN 60068-2-6

Data sheet

Operating and environmental conditions			
Valve function		T32-A <sup>1)</sup>	M52-A <sup>1)</sup>   B52
Operating medium		Compressed air to ISO 8573-1:2010 [7:4:4]	
Note on the operating/pilot medium		Lubricated operation possible (in which case lubricated operation will always be required)	
Operating pressure	[bar]	1.5 ... 7	2.5 ... 7   1.5 ... 7
Ambient temperature	[°C]	-5 ... +50	
Temperature of medium	[°C]	-5 ... +50	

1) Pneumatic spring

Electrical data	
Electrical connection	Via E-box → page 102
Operating voltage	[V DC] 24 ±10%
Nominal operating voltage	[V DC] 22
Power	[W] 0.7
Duty cycle	[%] 100
Degree of protection to EN 60529	IP40 (with plug socket), IP65 (with M8)
Signal status display	LED
Maximum switching frequency	[Hz] 2

Information on materials	
Housing	Wrought aluminium alloy
Seals	HNBR, NBR
Note on materials	RoHS-compliant Contains paint-wetting impairment substances

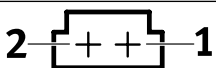
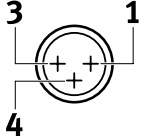
Pin allocation for E-box			
	Pin		Description
<b>Rectangular plug, connection pattern H</b>			
	1	+ or -	Protective circuit without holding current reduction
	2	+ or -	
<b>Round plug, M8, 3-pin</b>			
	1	Not used	Protective circuit without holding current reduction
	3	+ or -	
	4	+ or -	

Protective circuit without holding current reduction

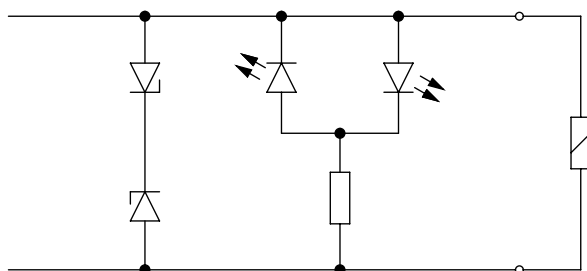

The solenoid coils are equipped with a protective circuit to arrest sparks and protect against polarity reversal.

Data sheet

**Dimensions**

Download CAD data → [www.festo.com](http://www.festo.com)

2x 3/2-way, 5/2-way valve, double solenoid

5/2-way valve, single solenoid

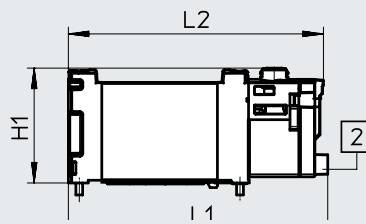
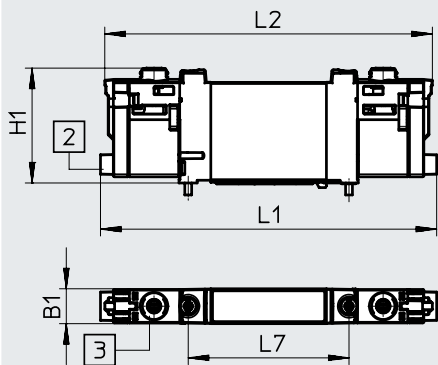

**Note**  
Additional dimensions  
E-boxes  
→ Page 104

[2] Horizontal electrical connection    [3] Manual override

Type	B1	H1	L1	L2	L7
VUVG-BK10-T32C...	10.2	33.6	98.3	95.8	47
VUVG-BK10-B52...			75.9	74.6	
VUVG-BK10-M52...					

Solenoid valves VUVG-BK10, sub-base valves M5/M7

Ordering data

★ Core product range

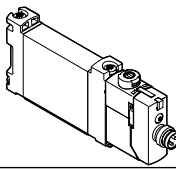
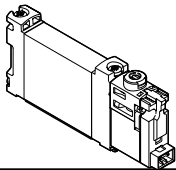
Ordering data		Description	Part no.	Type
<b>Sub-base valve M5/M7, with E-box R8</b>				
	<b>2x 3/2-way valve</b>			
	Internal pilot air supply	Normally closed, reset method: pneumatic spring	★ 8042558	VUVG-BK10-T32C-AT-F-1R8L-S
	<b>5/2-way valve, single solenoid</b>			
	Internal pilot air supply	Reset method: pneumatic spring	★ 8042559	VUVG-BK10-M52-AT-F-1R8L-S
<b>5/2-way valve, double solenoid</b>				
	Internal pilot air supply		★ 8042560	VUVG-BK10-B52-T-F-1R8L-S
<b>Sub-base valve M5/M7, with E-box H2</b>				
	<b>2x 3/2-way valve</b>			
	Internal pilot air supply	Normally closed, reset method: pneumatic spring	★ 8042554	VUVG-BK10-T32C-AT-F-1H2L-S
	<b>5/2-way valve, single solenoid</b>			
	Internal pilot air supply	Reset method: pneumatic spring	★ 8042555	VUVG-BK10-M52-AT-F-1H2L-S
<b>5/2-way valve, double solenoid</b>				
	Internal pilot air supply		★ 8042556	VUVG-BK10-B52-T-F-1H2L-S

Festo core product range



Generally ready for dispatch from the factory within 24 hours



Generally ready for dispatch from the factory within 5 days

Data sheet

Function

2x 3/2C, 2x 3/2U, 2x 3/2H  
 5/2-way, single solenoid  
 5/2-way, double solenoid valve  
 5/3C, 5/3U, 5/3E

Circuit symbols → page 13

-  - Size 10 mm
-  - Flow rate  
120 ... 270 l/min
-  - Voltage  
5, 12 and 24 V DC



General technical data VUVG-B

Valve function	T32-A			T32-M			M52-R	B52	M52-M	P53			
Normal position	C <sup>1)</sup>	U <sup>2)</sup>	H <sup>4)</sup>	C <sup>1)</sup>	U <sup>2)</sup>	H <sup>4)</sup>	-	-	-	C <sup>1)</sup>	U <sup>2)</sup>	E <sup>3)</sup>	
Stable position	Monostable							Bistable	Monostable	Monostable			
Reset method: pneumatic spring	Yes			No			Yes <sup>5)</sup>	-	No	-			
Reset method: mechanical spring	No			Yes			Yes <sup>5)</sup>	-	Yes	Yes			
Vacuum operation at port 1	No			Only with external pilot air supply									
Design	Piston spool												
Sealing principle	Soft												
Actuation type	Electric												
Type of control	Piloted												
Pilot air supply	External, internal; can be selected via sub-base												
Exhaust air function	Can be throttled												
Manual override	Choice of non-detenting, covered, non-detenting/detenting or detenting												
Type of mounting	On manifold rail												
Mounting position	Any												
Nominal size	[mm]	2.7			1.8	1.7		4		2.3		3.5	
Standard nominal flow rate	[l/min]	170			150	140		330		285		300	
Flow rate on manifold rail M5	[l/min]	150			130	120		210		180		200	
Flow rate on manifold rail M7	[l/min]	160			140	130		270		230		250	
Switching time on/off	[ms]	6/16			8/11			7/19		-	8/24		11/30
Switching time changeover	[ms]	-							7		14		
Size	[mm]	10											
Port	1, 3, 5	G1/8 in manifold rail											
	2, 4	M5 or M7 in manifold rail											
	12/14, 82/84	M5 in manifold rail											
Product weight	[g]	55			54			45	55	44	55		
Certification	c UL us – Recognized (OL)												
	c CSA us (OL)												
	RCM												
CE marking (see declaration of conformity) <sup>6)</sup>	To EU EMC Directive												
Corrosion resistance class CRC <sup>7)</sup>	2												

- 1) C=Normally closed/mid-position closed
- 2) U=Normally open/mid-position pressurised
- 3) E=Mid-position exhausted
- 4) H=2x 3/2-way valve in one housing with 1x normally closed and 1x normally open
- 5) Combined reset method
- 6) For information about the area of use, see the EC declaration of conformity at: [www.festo.com/sp](http://www.festo.com/sp) → Certificates.  
If the devices are subject to usage restrictions in residential, commercial or light-industrial environments, further measures for the reduction of the emitted interference may be necessary.
- 7) Corrosion resistance class CRC 2 to Festo standard FN 940070  
Moderate corrosion stress. Indoor applications in which condensation can occur. External visible parts with primarily decorative surface requirements which are in direct contact with a normal industrial environment.

Data sheet

Operating and environmental conditions			T32-A <sup>1)</sup>	T32-M <sup>3)</sup>	M52-R <sup>2)</sup>	B52	M52-M <sup>3)</sup>	P53
Valve function			Compressed air to ISO 8573-1:2010 [7:4:4]					
Operating pressure	Internal	[bar]	1.5 ... 8	3 ... 8	2.5 ... 8	1.5 ... 8	3 ... 8	
	External	[bar]	1.5 ... 10	-0.9 ... 10			-0.9 ... 8	-0.9 ... 10
Pilot pressure <sup>4)</sup>		[bar]	1.5 ... 8	2 ... 8	2.5 ... 8	1.5 ... 8	3 ... 8	
Ambient temperature		[°C]	-5 ... +50, with holding current reduction -5 ... +60					
Temperature of medium		[°C]	-5 ... +50, with holding current reduction -5 ... +60					

- 1) Pneumatic spring
- 2) Mixed, pneumatic/mechanical spring
- 3) Mechanical spring
- 4) Minimum pilot pressure 50% of operating pressure

Electrical data	
Electrical connection	Via E-box → page 102
Operating voltage	[V DC] 5, 12 and 24 ±10%
Power	[W] 1, reduced to 0.35 with holding current reduction
Duty cycle	[%] 100
Degree of protection to EN 60529	IP40 (with plug socket), IP65 (with M8)

Information on materials	
Housing	Wrought aluminium alloy
Seals	HNBR, NBR
Note on materials	RoHS-compliant

Dimensions

Download CAD data → [www.festo.com](http://www.festo.com)

2x 3/2-way, 5/2-way and 5/3-way valve

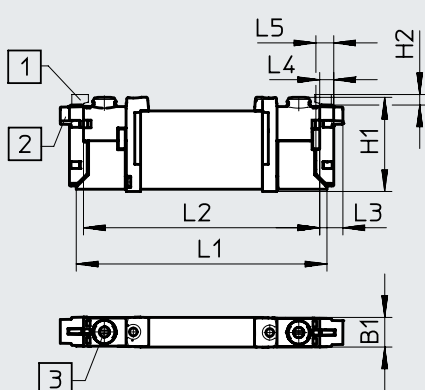

- - **Note**  
 Additional dimensions  
 E-boxes  
 → Page 104

- [1] Vertical electrical connection
- [2] Horizontal electrical connection
- [3] Manual override

Type	B1	H1	H2	L1	L2	L3	L4	L5	L6	L7
VUVG-B10 -...-F...	10.2	32.5	3.6	86.5	81.5	8	4.85	6.15	69.2	66.7

Ordering data

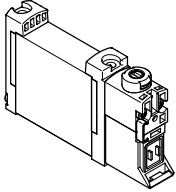
Ordering data	Description	Part no.	Type	
<b>Sub-base valve M5/M7, without E-box</b>				
	<b>2x 3/2-way valve</b>			
	External pilot air supply	Normally closed, reset method: pneumatic spring	566487	VUVG-B10-T32C-AZT-F-1P3
		Normally open, reset method: pneumatic spring	566488	VUVG-B10-T32U-AZT-F-1P3
		1x normally open, 1x normally closed, reset method: pneumatic spring	566489	VUVG-B10-T32H-AZT-F-1P3
		Normally closed, reset method: mechanical spring	574364	VUVG-B10-T32C-MZT-F-1P3
		Normally open, reset method: mechanical spring	574365	VUVG-B10-T32U-MZT-F-1P3
		1x normally open, 1x normally closed, reset method: mechanical spring	574366	VUVG-B10-T32H-MZT-F-1P3
	<b>5/2-way valve, single solenoid</b>			
	External pilot air supply	Reset method: pneumatic/mechanical spring	566490	VUVG-B10-M52-RZT-F-1P3
		Reset method: mechanical spring	574367	VUVG-B10-M52-MZT-F-1P3
	<b>5/2-way valve, double solenoid</b>			
	External pilot air supply		566491	VUVG-B10-B52-ZT-F-1P3
	<b>5/3-way valve</b>			
	External pilot air supply	Mid-position closed, reset method: mechanical spring	566492	VUVG-B10-P53C-ZT-F-1P3
Mid-position exhausted, reset method: mechanical spring		566493	VUVG-B10-P53E-ZT-F-1P3	
Mid-position pressurised, reset method: mechanical spring		566494	VUVG-B10-P53U-ZT-F-1P3	

Solenoid valves VUVG-B10, sub-base valves M5/M7

Ordering data

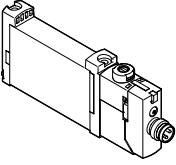
Ordering data	Description	Part no.	Type	
<b>Sub-base valve M5/M7, with E-box R8</b>				
	<b>2x 3/2-way valve</b>			
	External pilot air supply	Normally closed, reset method: pneumatic spring	574234	VUVG-B10-T32C-AZT-F-1R8L
		Normally open, reset method: pneumatic spring	574235	VUVG-B10-T32U-AZT-F-1R8L
		1x normally open, 1x normally closed, reset method: pneumatic spring	574236	VUVG-B10-T32H-AZT-F-1R8L
		Normally closed, reset method: mechanical spring	8031492	VUVG-B10-T32C-MZT-F-1R8L
		Normally open, reset method: mechanical spring	8031493	VUVG-B10-T32U-MZT-F-1R8L
		1x normally open, 1x normally closed, reset method: mechanical spring	8031494	VUVG-B10-T32H-MZT-F-1R8L
	<b>5/2-way valve, single solenoid</b>			
	External pilot air supply	Reset method: pneumatic/mechanical spring	574237	VUVG-B10-M52-RZT-F-1R8L
		Reset method: mechanical spring	578157	VUVG-B10-M52-MZT-F-1R8L
	<b>5/2-way valve, double solenoid</b>			
	External pilot air supply		574238	VUVG-B10-B52-ZT-F-1R8L
	<b>5/3-way valve</b>			
	External pilot air supply	Mid-position closed, reset method: mechanical spring	574239	VUVG-B10-P53C-ZT-F-1R8L
Mid-position exhausted, reset method: mechanical spring		574241	VUVG-B10-P53E-ZT-F-1R8L	
Mid-position pressurised, reset method: mechanical spring		574240	VUVG-B10-P53U-ZT-F-1R8L	



## Manifold assembly

Sub-base valve for  
Manifold assembly  
M5 or M7 connection



### Dimensions

Download CAD data → [www.festo.com](http://www.festo.com)

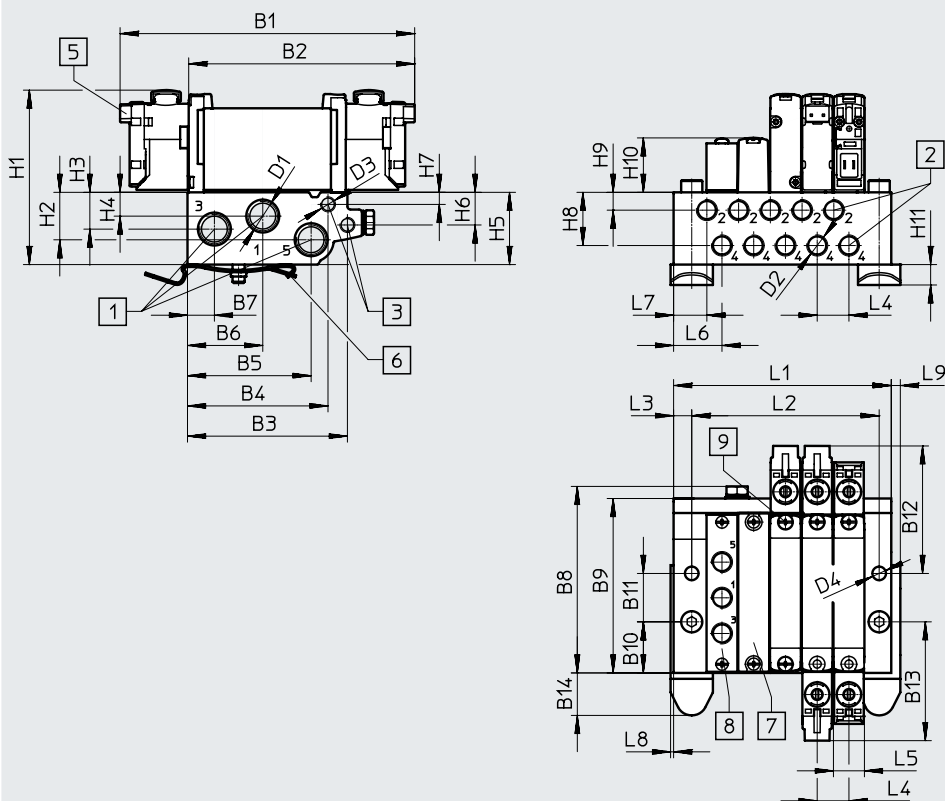

**Note**  
Additional dimensions  
E-boxes  
→ Page 104

- [1] Ports 1, 3 and 5: G1/8 (at both ends)
- [2] Ports 2, 4: M7 or M5
- [3] Ports 12, 14: M5
- [5] Electrical connection for E-boxes and accessories
- [6] H-rail mounting (two M4x30 screws are required for mounting)
- [7] Cover plate
- [8] Supply plate, ports 1, 3 and 5: either M5 or M7
- [9] Valves/cover plate mounting on manifold rail: M2 thread

Type	B1	B2	B3	B4	B5	B6	B7	B8	B9	B10	B11	B12
VABM-L1 10....-G18	97.5	74.8	52.9	46.5	40.9	24.9	8.9	61.7	57.7	16.9	16	42.2

Type	B13	B14	D1	D2	D3	D4	D5	H1	H2	H3	H4
VABM-L1 10....-G18	39.3	14.1	G1/8	M5/M7	M5	4.5	Ø 6	56.4	15.7	12.2	7.9

Type	H5	H6	H7	H8	H9	H10	H11	L3	L4	L5	L6	L7	L8	L9
VABM-L1 10....-G18	23.9	10.8	4	17.6	5.9	18	6.8	6	10.5	10.3	16	11.9	1	3

Solenoid valves VUVG-B10, sub-base valves M5/M7

Manifold assembly

Valve positions	2	3	4	5	6	7	8	9	10	12	14	16	22
L1	40.5	51	61.5	72	82.5	93	103.5	114	124.5	145.5	166.5	187.5	250.5
L2	30.5	41	51.5	62	72.5	83	93.5	104	114.5	135.5	156.5	177.5	240.5
Weight of VABM [g]	107	135	163	191	219	247	275	303	331	387	415	471	499

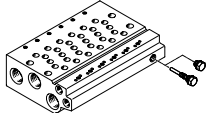
Technical data – Manifold rails <sup>1)</sup>									
	Port			CRC	Material <sup>3)</sup>	Operating pressure [bar]	Max. tightening torque for assembly [Nm]		
	2, 4	1, 3, 5	12/14, 82/84				Valve	H-rail	Wall
	M5 or M7	G1/8	M5	2 <sup>2)</sup>	Wrought aluminium alloy	-0.9 ... 10	0.45	1.5	3

- 1) Blanking plugs are included with the manifold rail.
- 2) Corrosion resistance class CRC 2 to Festo standard FN 940070  
Moderate corrosion stress. Indoor applications in which condensation can occur. External visible parts with primarily decorative surface requirements which are in direct contact with a normal industrial environment.
- 3) Note on materials: RoHS-compliant.

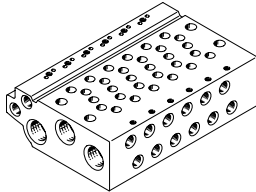
Ordering data – Manifold rails			
	Description	Part no.	Type
<b>Manifold rail for sub-base valve M5/M7</b>			
	For size B10 (M5)	2 valve positions	★ 566582 VABM-L1-10W-G18-2
		3 valve positions	★ 566583 VABM-L1-10W-G18-3
		4 valve positions	★ 566584 VABM-L1-10W-G18-4
		5 valve positions	566585 VABM-L1-10W-G18-5
		6 valve positions	★ 566586 VABM-L1-10W-G18-6
		7 valve positions	566587 VABM-L1-10W-G18-7
		8 valve positions	★ 566588 VABM-L1-10W-G18-8
		9 valve positions	566589 VABM-L1-10W-G18-9
		10 valve positions	★ 566590 VABM-L1-10W-G18-10
		12 valve positions	566591 VABM-L1-10W-G18-12
		14 valve positions	566592 VABM-L1-10W-G18-14
16 valve positions	566593 VABM-L1-10W-G18-16		

Festo core product range







Generally ready for dispatch from the factory within 24 hours

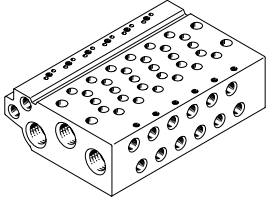
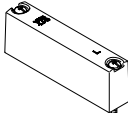

Generally ready for dispatch from the factory within 5 days

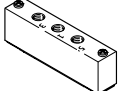
Manifold assembly

Ordering data – Accessories		Description	Part no.	Type
<b>Manifold rail for sub-base valve M5/M7</b>				
	For size B10 (M7)	2 valve positions	★ 566606	VABM-L1-10HW-G18-2
		3 valve positions	★ 566607	VABM-L1-10HW-G18-3
		4 valve positions	★ 566608	VABM-L1-10HW-G18-4
		5 valve positions	566609	VABM-L1-10HW-G18-5
		6 valve positions	★ 566610	VABM-L1-10HW-G18-6
		7 valve positions	566611	VABM-L1-10HW-G18-7
		8 valve positions	★ 566612	VABM-L1-10HW-G18-8
		9 valve positions	566613	VABM-L1-10HW-G18-9
		10 valve positions	★ 566614	VABM-L1-10HW-G18-10
		12 valve positions	566615	VABM-L1-10HW-G18-12
		14 valve positions	566616	VABM-L1-10HW-G18-14
16 valve positions	566617	VABM-L1-10HW-G18-16		
<b>Cover plate</b> <span style="float: right;">Data sheets → Internet: vabb</span>				
	For valve position on manifold rail, including screws and seal	★ 566495	VABB-L1-10-W	
<b>Separator</b> <span style="float: right;">Data sheets → Internet: vabd</span>				
	For creating pressure zones	569994	VABD-6-B	
<b>Supply plate</b> <span style="float: right;">Data sheets → Internet: vabf</span>				
	For valve position (sub-base valves M5) on manifold rail, including screws and seal	569991	VABF-L1-10-P3A4-M5	
	For valve position (sub-base valves M7) on manifold rail, including screws and seal	569992	VABF-L1-10-P3A4-M7	
<b>Seals</b> <span style="float: right;">Data sheets → Internet: vabd</span>				
	For sub-base valves M5/M7	Delivery quantity: 10 sets (each with 2 screws and 1 seal)	566674	VABD-L1-10B-S-M7

Festo core product range





Generally ready for dispatch from the factory within 24 hours

Generally ready for dispatch from the factory within 5 days

Solenoid valves VUVG-BK14, sub-base valves G1/8

Data sheet

Function  
2x 3/2C  
5/2-way, single solenoid  
5/2-way, double solenoid valve

-  - Size 14 mm
-  - Flow rate  
350 ... 380 l/min
-  - Voltage  
24 V DC

Circuit symbols → page 13

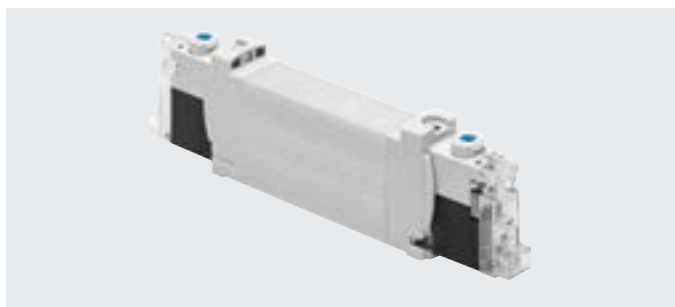

**General technical data VUVG-BK**

Valve function	T32-A	M52-A	B52
Normal position	C <sup>1)</sup>	-	-
Stable position	Monostable		Bistable
Reset method: pneumatic spring	Yes	Yes	-
Design	Piston spool		
Sealing principle	Soft		
Actuation type	Electric		
Type of control	Piloted		
Pilot air supply	Internal		
Exhaust air function	Can be throttled		
Manual override	Non-detenting, detenting		
Type of mounting	On manifold rail		
Mounting position	Any		
Standard nominal flow rate	[l/min]	350	380
Switching time on/off	[ms]	13/20	14/24
Switching time changeover	[ms]	-	8
Size	[mm]	14	
Port	2, 4	G1/8 in manifold rail	
Product weight	[g]	75	65
Corrosion resistance class CRC <sup>2)</sup>		2	

1) C=Normally closed

2) Corrosion resistance class CRC 2 to Festo standard FN 940070

Moderate corrosion stress. Indoor applications in which condensation can occur. External visible parts with primarily decorative surface requirements which are in direct contact with a normal industrial environment.

**Safety data**

Max. positive test pulse with 0 signal	[µs]	1600
Max. negative test pulse with 1 signal	[µs]	3000
Shock resistance	Shock test with severity level 1 to FN 942017-5 and EN 60068-2-27	
Vibration resistance	Transport application test with severity level 1 to FN 942017-4 and EN 60068-2-6	

Data sheet

Operating and environmental conditions			
Valve function		T32-A <sup>1)</sup>	M52-A <sup>1)</sup>   B52
Operating medium		Compressed air to ISO 8573-1:2010 [7:4:4]	
Note on the operating/pilot medium		Lubricated operation possible (in which case lubricated operation will always be required)	
Operating pressure	[bar]	1.5 ... 7	2.5 ... 7   1.5 ... 7
Ambient temperature	[°C]	-5 ... +50	
Temperature of medium	[°C]	-5 ... +50	

1) Pneumatic spring

Electrical data	
Electrical connection	Via E-box → page 102
Operating voltage	[V DC] 24 ±10%
Nominal operating voltage	[V DC] 22
Power	[W] 0.7
Duty cycle	[%] 100
Degree of protection to EN 60529	IP40 (with plug socket), IP65 (with M8)
Signal status display	LED
Maximum switching frequency	[Hz] 2

Information on materials	
Housing	Wrought aluminium alloy
Seals	HNBR, NBR
Note on materials	RoHS-compliant Contains paint-wetting impairment substances

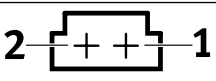
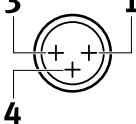
Pin allocation for E-box			
	Pin		Description
<b>Rectangular plug, connection pattern H</b>			
	1	+ or -	Protective circuit without holding current reduction
	2	+ or -	
<b>Round plug, M8, 3-pin</b>			
	1	Not used	Protective circuit without holding current reduction
	3	+ or -	
	4	+ or -	

Protective circuit without holding current reduction

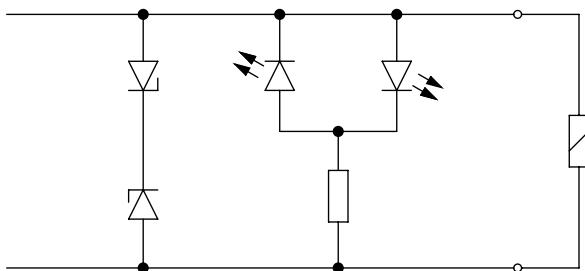

The solenoid coils are equipped with a protective circuit to arrest sparks and protect against polarity reversal.

Data sheet

**Dimensions**

Download CAD data → [www.festo.com](http://www.festo.com)

2x 3/2-way, 5/2-way valve, single solenoid

5/2-way valve, double solenoid

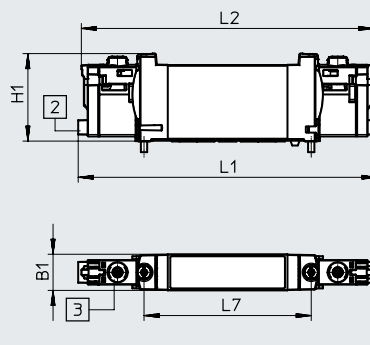
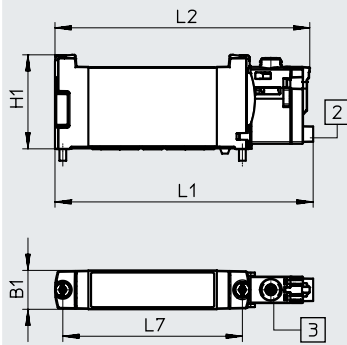

**Note**  
Additional dimensions  
E-boxes  
→ Page 104

[2] Horizontal electrical connection

[3] Manual override

Type	B1	H1	L1	L2	L7
VUVG-BK14-T32C-...	14.4	34.8	118.9	116.4	66.5
VUVG-BK14-B52-...					
VUVG-BK14-M52-...			95.6	94.4	

Ordering data

★ Core product range

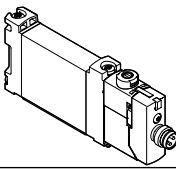
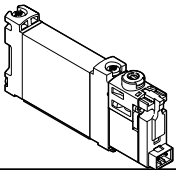
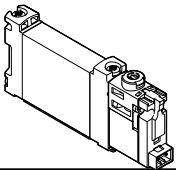
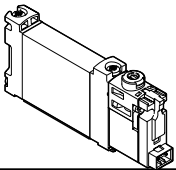
Ordering data	Description	Part no.	Type
<b>Sub-base valve G1/8, with E-box R8</b>			
	<b>2x 3/2-way valve</b>		
	Internal pilot air supply	Normally closed, reset method: pneumatic spring	★ 8042574 VUVG-BK14-T32C-AT-F-1R8L-S
	<b>5/2-way valve, single solenoid</b>		
	Internal pilot air supply	Reset method: pneumatic spring	★ 8042575 VUVG-BK14-M52-AT-F-1R8L-S
	<b>5/2-way valve, double solenoid</b>		
	Internal pilot air supply		★ 8042576 VUVG-BK14-B52-T-F-1R8L-S
	<b>Sub-base valve G1/8, with E-box H2</b>		
	<b>2x 3/2-way valve</b>		
	Internal pilot air supply	Normally closed, reset method: pneumatic spring	★ 8042570 VUVG-BK14-T32C-AT-F-1H2L-S
	<b>5/2-way valve, single solenoid</b>		
	Internal pilot air supply	Reset method: pneumatic spring	★ 8042571 VUVG-BK14-M52-AT-F-1H2L-S
	<b>5/2-way valve, double solenoid</b>		
	Internal pilot air supply		★ 8042572 VUVG-BK14-B52-T-F-1H2L-S

Festo core product range





Generally ready for dispatch from the factory within 24 hours

Generally ready for dispatch from the factory within 5 days

Solenoid valves VUVG-B14, sub-base valves G1/8

Data sheet

Function  
 2x 3/2C, 2 x3/2U, 2 x3/2  
 5/2-way, single solenoid  
 5/2-way, double solenoid valve  
 5/3C, 5/3U, 5/3E

-  - Size 14 mm
-  - Flow rate  
410 ... 700 l/min
-  - Voltage  
5, 12 and 24 V DC



Circuit symbols → page 13

General technical data VUVG-B													
Valve function		T32-A			T32-M			M52-A	B52	M52-M	P53		
Normal position		C <sup>1)</sup>	U <sup>2)</sup>	H <sup>4)</sup>	C <sup>1)</sup>	U <sup>2)</sup>	H <sup>4)</sup>	–	–	–	C <sup>1)</sup>	U <sup>2)</sup>	E <sup>3)</sup>
Stable position		Monostable							Bistable	Monostable	Monostable		
Reset method: pneumatic spring		Yes			No			Yes	–	No	–		
Reset method: mechanical spring		No			Yes			No	–	Yes	Yes		
Vacuum operation at port 1		No			Only with external pilot air supply								
Size	[mm]	14											
Design		Piston spool											
Sealing principle		Soft											
Actuation type		Electric											
Type of control		Piloted											
Pilot air supply		External, internal; can be selected via sub-base											
Exhaust air function		Can be throttled											
Manual override		Choice of non-detenting, covered, non-detenting/detenting or detenting											
Type of mounting		On manifold rail											
Mounting position		Any											
Nominal size	[mm]	4.6			4.3			5.6					
Standard nominal flow rate	[l/min]	600	580		470	450		630	680		600	580	580
Flow rate on manifold rail G1/8	[l/min]	510			430	410		520	570		520	500	460
Switching time	On/off	8/23			15/11			14/22	–	13/40	12/40		
	Changeover	–			–			–	8	–	20		
Pneumatic connection	1, 3, 5	G1/4 in manifold rail											
	2, 4	G1/8 in manifold rail											
	12/14, 82/84	M5 in manifold rail											
Product weight	[g]	89			80			78	89	70	89		
Certification		c UL us – Recognized (OL)											
		c CSA us (OL)											
		RCM											
CE marking (see declaration of conformity) <sup>5)</sup>		To EU EMC Directive											
		to EU Low Voltage Directive											
Corrosion resistance class CRC <sup>6)</sup>		2											

1) C=Normally closed/mid-position closed  
 2) U=Normally open/mid-position pressurised  
 3) E=Mid-position exhausted  
 4) H=2x 3/2-way valve in one housing with 1x normally closed and 1x normally open  
 5) For information about the area of use, see the EC declaration of conformity at: [www.festo.com/sp](http://www.festo.com/sp) → Certificates.  
 If the devices are subject to usage restrictions in residential, commercial or light-industrial environments, further measures for the reduction of the emitted interference may be necessary.  
 6) Corrosion resistance class CRC 2 to Festo standard FN 940070  
 Moderate corrosion stress. Indoor applications in which condensation can occur. External visible parts with primarily decorative surface requirements which are in direct contact with a normal industrial environment.



Data sheet

Operating and environmental conditions		T32-A <sup>1)</sup>	T32-M <sup>2)</sup>	M52-A <sup>1)</sup>	B52	M52-M <sup>2)</sup>	P53
Valve function		Compressed air to ISO 8573-1:2010 [7:4:4]					
Note on the operating/pilot medium		Lubricated operation possible (in which case lubricated operation will always be required)					
Operating pressure	Internal [bar]	1.5 ... 8	3 ... 8	2.5 ... 8	1.5 ... 8	3 ... 8	
	External [bar]	1.5 ... 10	-0.9 ... 10			-0.9 ... 8	-0.9 ... 10
Pilot pressure <sup>3)</sup> [bar]		1.5 ... 8	3 ... 8	2.5 ... 8	1.5 ... 8	3 ... 8	
Ambient temperature [°C]		-5 ... +50, with holding current reduction -5 ... +60					
Temperature of medium [°C]		-5 ... +50, with holding current reduction -5 ... +60					

- 1) Pneumatic spring
- 2) Mechanical spring
- 3) Minimum pilot pressure 50% of the operating pressure

Electrical data		
Electrical connection		Via E-box → page 102
Operating voltage [V DC]	5, 12 and 24 ±10%	
Power [W]	1, reduced to 0.35 with holding current reduction	
Duty cycle [%]	100	
Degree of protection to EN 60529		IP40 (with plug socket), IP65 (with M8)

Information on materials	
Housing	Wrought aluminium alloy
Seals	HNBR, NBR
Note on materials	RoHS-compliant

Data sheet

**Dimensions VUVG**

Download CAD data → [www.festo.com](http://www.festo.com)

2x 3/2-way, 5/2-way and 5/3-way valve

5/2-way valve, single solenoid

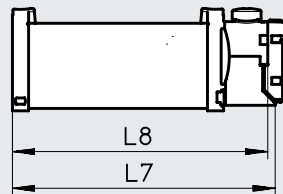
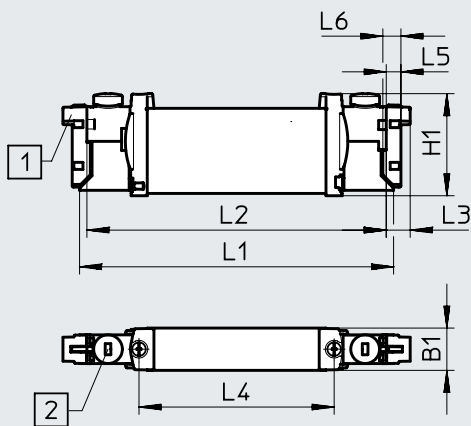

-  - **Note**  
Additional dimensions  
E-boxes  
→ Page 104

[1] Horizontal electrical connection    [2] Manual override

Type	B1	H1	L1	L2	L3	L4	L5	L6	L7	L8
VUVG-B14 -...-F ...	14	34.8	107	102	8	66.5	4.9	6.2	89.5	87

Ordering data

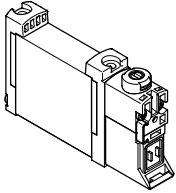
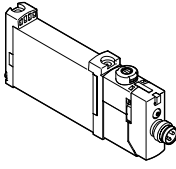
Ordering data	Description	Part no.	Type	
<b>Sub-base valve G1/8, without E-box</b>				
	<b>2x 3/2-way valve</b>			
	External pilot air supply	Normally closed, reset method: pneumatic spring	566513	VUVG-B14-T32C-AZT-F-1P3
		Normally open, reset method: pneumatic spring	566514	VUVG-B14-T32U-AZT-F-1P3
		1x normally open, 1x normally closed, reset method: pneumatic spring	566515	VUVG-B14-T32H-AZT-F-1P3
		Normally closed, reset method: mechanical spring	574376	VUVG-B14-T32C-MZT-F-1P3
		Normally open, reset method: mechanical spring	574377	VUVG-B14-T32U-MZT-F-1P3
		1x normally open, 1x normally closed, reset method: mechanical spring	574378	VUVG-B14-T32H-MZT-F-1P3
	<b>5/2-way valve, single solenoid</b>			
	External pilot air supply	Reset method: pneumatic spring	566516	VUVG-B14-M52-AZT-F-1P3
		Reset method: mechanical spring	574379	VUVG-B14-M52-MZT-F-1P3
	<b>5/2-way valve, double solenoid</b>			
	External pilot air supply		566517	VUVG-B14-B52-ZT-F-1P3
	<b>5/3-way valve</b>			
	External pilot air supply	Mid-position closed, reset method: mechanical spring	566518	VUVG-B14-P53C-ZT-F-1P3
Mid-position exhausted, reset method: mechanical spring		566519	VUVG-B14-P53E-ZT-F-1P3	
Mid-position pressurised, reset method: mechanical spring		566520	VUVG-B14-P53U-ZT-F-1P3	
<b>Sub-base valve G1/8, with E-box R8</b>				
	<b>2x 3/2-way valve</b>			
	External pilot air supply	Normally closed, reset method: pneumatic spring	574242	VUVG-B14-T32C-AZT-F-1R8L
		Normally open, reset method: pneumatic spring	574243	VUVG-B14-T32U-AZT-F-1R8L
		1x normally open, 1x normally closed, reset method: pneumatic spring	574244	VUVG-B14-T32H-AZT-F-1R8L
		Normally closed, reset method: mechanical spring	578248	VUVG-B14-T32C-MZT-F-1R8L
		Normally open, reset method: mechanical spring	8031517	VUVG-B14-T32U-MZT-F-1R8L
		1x normally open, 1x normally closed, reset method: mechanical spring	8031518	VUVG-B14-T32H-MZT-F-1R8L
	<b>5/2-way valve, single solenoid</b>			
	External pilot air supply	Reset method: pneumatic spring	574245	VUVG-B14-M52-AZT-F-1R8L
		Reset method: mechanical spring	578158	VUVG-B14-M52-MZT-F-1R8L
	<b>5/2-way valve, double solenoid</b>			
	External pilot air supply		574246	VUVG-B14-B52-ZT-F-1R8L
	<b>5/3-way valve</b>			
	External pilot air supply	Mid-position closed, reset method: mechanical spring	574247	VUVG-B14-P53C-ZT-F-1R8L
Mid-position exhausted, reset method: mechanical spring		574249	VUVG-B14-P53E-ZT-F-1R8L	
Mid-position pressurised, reset method: mechanical spring		574248	VUVG-B14-P53U-ZT-F-1R8L	

Manifold assembly

Sub-base valve for manifold assembly  
Connection G1/8



Dimensions

Download CAD data → [www.festo.com](http://www.festo.com)

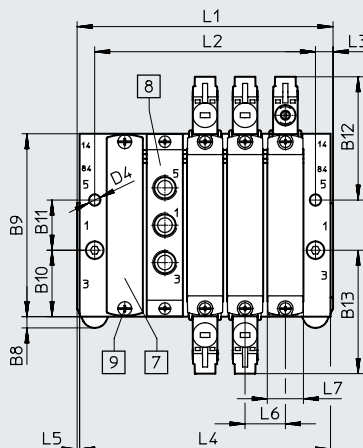
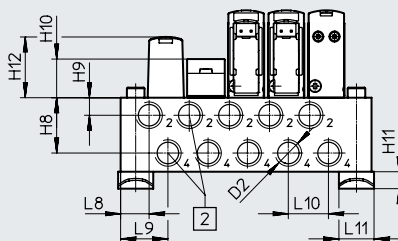
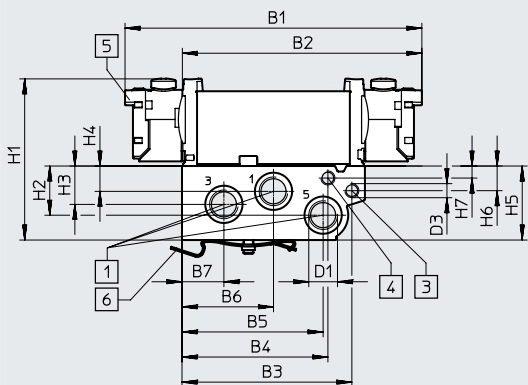

**Note**  
Additional dimensions  
E-boxes  
→ Page 104

- [1] Ports 1, 3 and 5: G1/4 (at both ends)
- [2] Ports 2, 4: G1/8
- [3] Ports 12, 14: M5
- [4] Ports 82, 84: M5
- [5] Electrical connection for E-boxes and accessories
- [6] H-rail mounting (two M4x35 screws are required for mounting)
- [7] Cover plate
- [8] Supply plate: ports 1, 3 and 5: G1/8
- [9] Valves/cover plate mounting on manifold rail: M2.5 thread

Type	B1	B2	B3	B4	B5	B6	B7	B8	B9	B10	B11	B12
VABM-L1-14W-G14	118.3	95.1	67.7	58.2	56.3	36.6	16.7	4.5	72.9	26.5	20	49.1

Type	B13	D1	D2	D3	D4	H1	H2	H3	H4	H5
VABM-L1-14W-G14	49.1	G1/4	G1/8	M5	∅ 4.5	64.3	19.6	15.3	10.1	29.5

Type	H6	H7	H8	H9	H10	H11	H12	L3	L5	L6	L7	L8	L9	L10	L11
VABM-L1-14W-G14	9.8	4.8	22.1	7	15.4	6.8	23.9	6	1	16	14.4	11.3	18.5	16	14

**Ordering data**

Valve positions	2	3	4	5	6	7	8	9	10	12	14	16
L1	56.3	72.3	88.3	104.3	120.3	136.3	152.3	168.3	184.3	216.3	248.3	280.3
L2	40	56	72	88	104	120	136	152	168	200	232	264
L4	54.3	70.3	86.3	102.3	118.3	134.3	150.3	166.3	182.3	214.3	246.6	278.3
Weight of VABM [g]	232	306	380	454	528	602	676	750	824	972	1120	1268

**Technical data – Manifold rails<sup>1)</sup>**

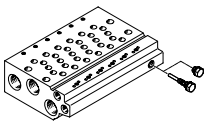
	Port			CRC	Material <sup>3)</sup>	Operating pressure [bar]	Max. tightening torque for assembly [Nm]		
	2, 4	1, 3, 5	12/14, 82/84				Valve	H-rail	Wall
	G1/8	G1/4	M5	2 <sup>2)</sup>	Wrought aluminium alloy	-0.9 ... 10	0.65	1.5	3

- 1) Blanking plugs are included with the manifold rail.
- 2) Corrosion resistance class CRC 2 to Festo standard FN 940070  
Moderate corrosion stress. Indoor applications in which condensation can occur. External visible parts with primarily decorative surface requirements which are in direct contact with a normal industrial environment.
- 3) Note on materials: RoHS-compliant.

**Ordering data – Manifold rail**

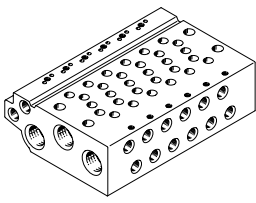
	Description	Part no.	Type
<b>Manifold rail for sub-base valve G1/8</b>			
	For size B14 (G1/8)	2 valve positions	★ 566642 VABM-L1-14W-G14-2
		3 valve positions	★ 566643 VABM-L1-14W-G14-3
		4 valve positions	★ 566644 VABM-L1-14W-G14-4
		5 valve positions	566645 VABM-L1-14W-G14-5
		6 valve positions	★ 566646 VABM-L1-14W-G14-6
		7 valve positions	566647 VABM-L1-14W-G14-7
		8 valve positions	★ 566648 VABM-L1-14W-G14-8
		9 valve positions	566649 VABM-L1-14W-G14-9
		10 valve positions	★ 566650 VABM-L1-14W-G14-10
		12 valve positions	566651 VABM-L1-14W-G14-12
		14 valve positions	566652 VABM-L1-14W-G14-14
		16 valve positions	566653 VABM-L1-14W-G14-16



Festo core product range



Generally ready for dispatch from the factory within 24 hours  
Generally ready for dispatch from the factory within 5 days

Solenoid valves VUVG-B14, sub-base valves G1/8

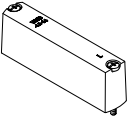
Ordering data

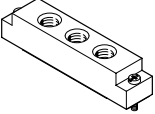
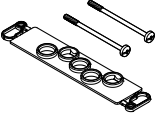
Ordering data – Accessories		Description	Part no.	Type
Data sheets → Internet: vabb				
	For valve position on manifold rail, including screws and seal	★ 569989	VABB-L1-14	
Data sheets → Internet: vabd				
	For creating pressure zones	569996	VABD-10-B	
Data sheets → Internet: vabf				
	For valve position on manifold rail, including screws and seal	569993	VABF-L1-14-P3A4-G18	
Data sheets → Internet: vabd				
	For sub-base valves G1/8	Delivery quantity: 10 sets (each with 2 screws and 1 seal)	566676	VABD-L1-14B-S-G18

Festo core product range



Generally ready for dispatch from the factory within 24 hours



Generally ready for dispatch from the factory within 5 days

Data sheet

Function

2x 3/2C, 2x 3/2U, 2x 3/2H  
 5/2-way, single solenoid  
 5/2-way, double solenoid valve  
 5/3C, 5/3U, 5/3E

Circuit symbols → page 13

-  - Size 18 mm
-  - Flow rate  
800 ... 1080 l/min
-  - Voltage  
5, 12 and 24 V DC



General technical data VUVG-B												
Valve function	T32-A			T32-M			M52-R	B52	M52-M	P53		
Normal position	C <sup>1)</sup>	U <sup>2)</sup>	H <sup>4)</sup>	C <sup>1)</sup>	U <sup>2)</sup>	H <sup>4)</sup>	–	–	–	C <sup>1)</sup>	U <sup>2)</sup>	E <sup>3)</sup>
Stable position	Monostable							Bistable	Monostable	Monostable		
Reset method: pneumatic spring	Yes			No			Yes <sup>5)</sup>	–	No	–		
Reset method: mechanical spring	No			Yes			Yes <sup>5)</sup>	–	Yes	Yes		
Vacuum operation at port 1	No			Only with external pilot air supply								
Design	Piston spool											
Sealing principle	Soft											
Actuation type	Electric											
Type of control	Piloted											
Pilot air supply	External, internal; can be selected via sub-base											
Exhaust air function	Can be throttled											
Manual override	Choice of non-detenting, covered, non-detenting/detenting or detenting											
Type of mounting	On manifold rail											
Mounting position	Any											
Nominal size	[mm]	5.7					6.9	7.3	6.9	6.5		
Standard nominal flow rate	[l/min]	900					1150			1080		
Flow rate on manifold rail		800					1000			950		
Switching time on/off	[ms]	13/27			15/22			15/31	–	10/45		15/48
Switching time changeover	[ms]	–					11			29		
Size	[mm]	18										
Port	1, 3, 5	G3/8 in manifold rail										
	2, 4	G1/4 in manifold rail										
	12/14, 82/84	M5 in manifold rail										
Product weight	[g]	164					154	160	154	160		
Certification	c UL us – Recognized (OL)											
	c CSA us (OL)											
	RCM											
CE marking (see declaration of conformity) <sup>6)</sup>	To EU EMC Directive											
Corrosion resistance class CRC <sup>7)</sup>	2											

1) C=Normally closed/mid-position closed  
 2) U=Normally open/mid-position pressurised  
 3) E=Mid-position exhausted  
 4) H=2x 3/2-way valve in one housing with 1x normally closed and 1x normally open  
 5) Combined reset method  
 6) For information about the area of use, see the EC declaration of conformity at: [www.festo.com/sp](http://www.festo.com/sp) → Certificates.  
 If the devices are subject to usage restrictions in residential, commercial or light-industrial environments, further measures for the reduction of the emitted interference may be necessary.  
 7) Corrosion resistance class CRC 2 to Festo standard FN 940070  
 Moderate corrosion stress. Indoor applications in which condensation can occur. External visible parts with primarily decorative surface requirements which are in direct contact with a normal industrial environment.

Data sheet

Operating and environmental conditions			T32-A <sup>1)</sup>	T32-M <sup>3)</sup>	M52-R <sup>2)</sup>	B52	M52-M <sup>3)</sup>	P53
Valve function			Compressed air to ISO 8573-1:2010 [7:4:4]					
Operating pressure	Internal	[bar]	1.5 ... 8	3.5 ... 8	2.5 ... 8	1.5 ... 8	3 ... 8	
	External	[bar]	1.5 ... 10	-0.9 ... 10			-0.9 ... 8	-0.9 ... 10
Pilot pressure <sup>4)</sup>		[bar]	1.5 ... 8	3 ... 8	2.5 ... 8	1.5 ... 8	3 ... 8	
Ambient temperature		[°C]	-5 ... +50, with holding current reduction -5 ... +60					
Temperature of medium		[°C]	-5 ... +50, with holding current reduction -5 ... +60					

- 1) Pneumatic spring
- 2) Mixed, pneumatic/mechanical spring
- 3) Mechanical spring
- 4) Minimum pilot pressure 50% of operating pressure

Electrical data	
Electrical connection	Via E-box → page 102
Operating voltage	[V DC] 5, 12 and 24 ±10%
Power	[W] 1, reduced to 0.35 with holding current reduction
Duty cycle	[%] 100
Degree of protection to EN 60529	IP40 (with plug socket), IP65 (with M8)

Information on materials	
Housing	Wrought aluminium alloy
Seals	HNBR, NBR
Note on materials	RoHS-compliant

**Dimensions** Download CAD data → [www.festo.com](http://www.festo.com)

2x 3/2-way, 5/2-way and 5/3-way valve

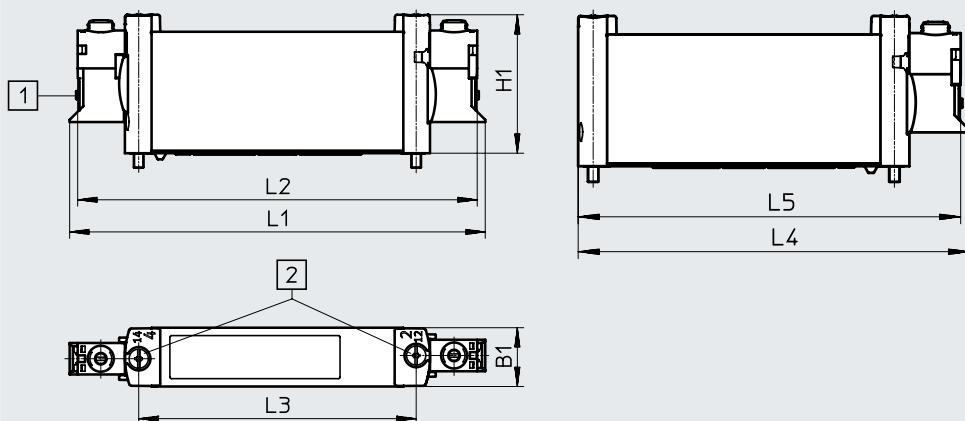

[1] Horizontal electrical connection    [2] Manual override

Type	B1	H1	L1	L2	L3	L4	L5
VUVG-B18 -...-F...	18.3	43.1	129.4	124.4	86.4	112.2	109.7

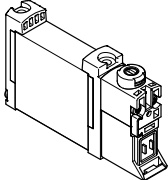

Ordering data

Ordering data	Description	Part no.	Type	
<b>Sub-base valve G1/4, without E-box</b>				
	<b>2x 3/2-way valve</b>			
	External pilot air supply	Normally closed, reset method: pneumatic spring	574443	VUVG-B18-T32C-AZT-F-1P3
		Normally open, reset method: pneumatic spring	574444	VUVG-B18-T32U-AZT-F-1P3
		1x normally open, 1x normally closed, reset method: pneumatic spring	574445	VUVG-B18-T32H-AZT-F-1P3
		Normally closed, reset method: mechanical spring	574446	VUVG-B18-T32C-MZT-F-1P3
		Normally open, reset method: mechanical spring	574447	VUVG-B18-T32U-MZT-F-1P3
		1x normally open, 1x normally closed, reset method: mechanical spring	574448	VUVG-B18-T32H-MZT-F-1P3
	<b>5/2-way valve, single solenoid</b>			
	External pilot air supply	Reset method: pneumatic/mechanical spring	574449	VUVG-B18-M52-RZT-F-1P3
		Reset method: mechanical spring	574450	VUVG-B18-M52-MZT-F-1P3
	<b>5/2-way valve, double solenoid</b>			
	External pilot air supply		574451	VUVG-B18-B52-ZT-F-1P3
	<b>5/3-way valve</b>			
	External pilot air supply	Mid-position closed, reset method: mechanical spring	574452	VUVG-B18-P53C-ZT-F-1P3
Mid-position exhausted, reset method: mechanical spring		574453	VUVG-B18-P53E-ZT-F-1P3	
Mid-position pressurised, reset method: mechanical spring		574454	VUVG-B18-P53U-ZT-F-1P3	

Solenoid valves VUVG-B18, sub-base valves G1/4

Ordering data

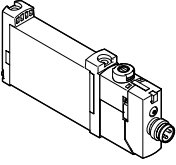
Ordering data	Description	Part no.	Type	
<b>Sub-base valve G1/4, with E-box R8</b>				
	<b>2x 3/2-way valve</b>			
	External pilot air supply	Normally closed, reset method: pneumatic spring	8031537	VUVG-B18-T32C-AZT-F-1R8L
		Normally open, reset method: pneumatic spring	8031538	VUVG-B18-T32U-AZT-F-1R8L
		1x normally open, 1x normally closed, reset method: pneumatic spring	8031539	VUVG-B18-T32H-AZT-F-1R8L
		Normally closed, reset method: mechanical spring	8031540	VUVG-B18-T32C-MZT-F-1R8L
		Normally open, reset method: mechanical spring	8031541	VUVG-B18-T32U-MZT-F-1R8L
		1x normally open, 1x normally closed, reset method: mechanical spring	8031542	VUVG-B18-T32H-MZT-F-1R8L
	<b>5/2-way valve, single solenoid</b>			
	External pilot air supply	Reset method: pneumatic/mechanical spring	8031543	VUVG-B18-M52-RZT-F-1R8L
		Reset method: mechanical spring	8031544	VUVG-B18-M52-MZT-F-1R8L
	<b>5/2-way valve, double solenoid</b>			
	External pilot air supply		8031545	VUVG-B18-B52-ZT-F-1R8L
	<b>5/3-way valve</b>			
	External pilot air supply	Mid-position closed, reset method: mechanical spring	8031546	VUVG-B18-P53C-ZT-F-1R8L
Mid-position exhausted, reset method: mechanical spring		8031547	VUVG-B18-P53E-ZT-F-1R8L	
Mid-position pressurised, reset method: mechanical spring		8031548	VUVG-B18-P53U-ZT-F-1R8L	

### Manifold assembly

Sub-base valve for manifold assembly  
Connection G1/4



#### Dimensions

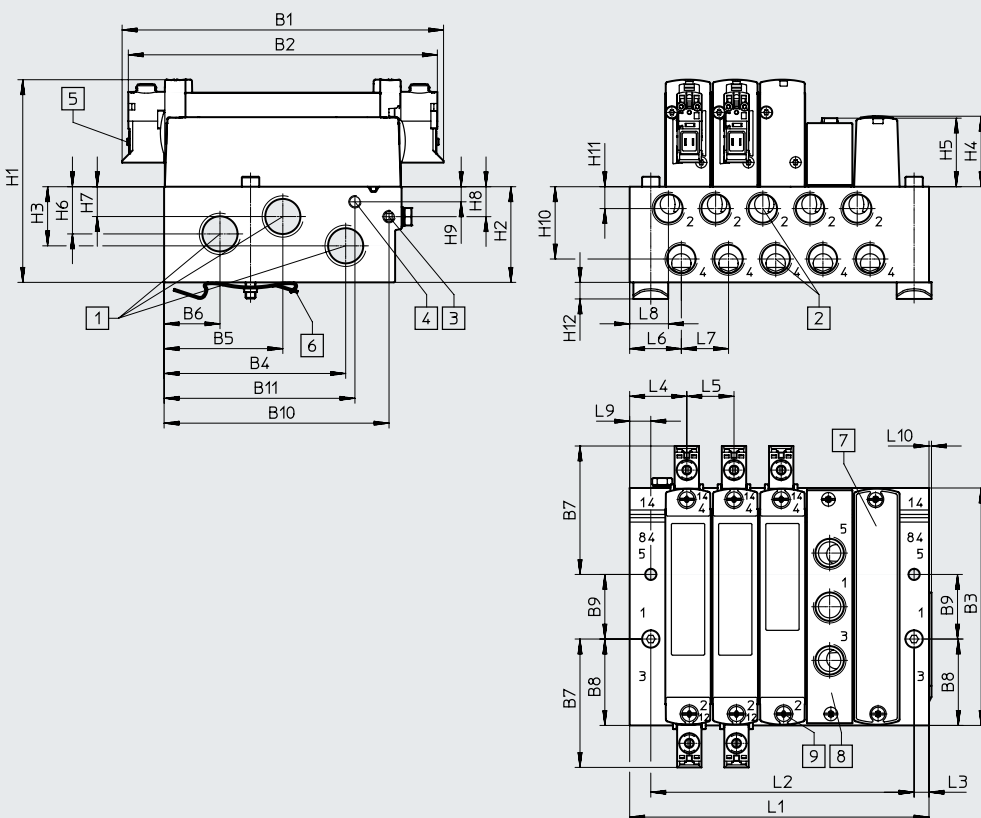

Download CAD data → [www.festo.com](http://www.festo.com)

- - **Note**  
Additional dimensions  
E-boxes  
→ Page 104

- [1] Ports 1, 3 and 5: G3/8 (at both ends)
- [2] Ports 2, 4: G1/4
- [3] Ports 12, 14: M5
- [4] Ports 82, 84: M5
- [5] Electrical connection for E-boxes and accessories
- [6] H-rail mounting (two M4x40 screws are required for mounting)
- [7] Cover plate
- [8] Supply plate, ports 1, 3 and 5: G1/4
- [9] Valve/cover plate/supply plate mounting on manifold rail: M3 thread

Type	B1	B2	B3	B4	B5	B6	B7	B8	B9	B10	B11	D1
VABM-L1-18W-G38	129.4	124.4	95.6	73.1	47.8	22.5	51.7	34.8	26	90.6	76.8	4.5

Type	H1	H2	H3	H4	H5	H6	H7	H8	H9	H10	H11	H12
VABM-L1-18W-G38	81.6	38.5	11.5	28.4	27.6	19	12	12.1	6.1	29.1	8.8	6.5

Type	L3	L4	L5	L6	L7	L8	L9	L10
VABM-L1-18W-G38	6	23	19	20.8	19	15.6	8.5	1

Solenoid valves VUVG-B18, sub-base valves G1/4

Ordering data

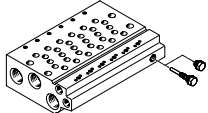

Valve positions	2	3	4	5	6	7	8	9	10	12	14	16
L1	63.5	82.5	101.5	120.5	139.5	158.5	177.5	196.5	215.5	253.5	291.5	329.5
L2	49	68	87	106	125	144	163	182	201	239	277	315
Weight of VABM [g]	232	306	380	454	528	602	676	750	824	972	1120	1268

Technical data – Manifold rails <sup>1)</sup>									
	Port			CRC	Material <sup>3)</sup>	Operating pressure [bar]	Max. tightening torque for assembly [Nm]		
	2, 4	1, 3, 5	12/14, 82/84				Valve	H-rail	Wall
	G1/4	G3/8	M5	2 <sup>2)</sup>	Wrought aluminium alloy	-0.9 ... 10	1.18	1.5	3

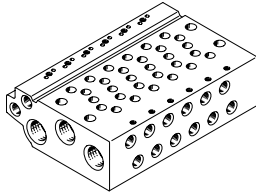
- 1) Blanking plugs are included with the manifold rail.
- 2) Corrosion resistance class CRC 2 to Festo standard FN 940070  
Moderate corrosion stress. Indoor applications in which condensation can occur. External visible parts with primarily decorative surface requirements which are in direct contact with a normal industrial environment.
- 3) Note on materials: RoHS-compliant.

Ordering data – Manifold rails			
	Description	Part no.	Type
<b>Manifold rail for sub-base valve G1/4</b>			
	For size B18 (G1/4)	2 valve positions	574467 VABM-L1-18W-G38-2
		3 valve positions	574468 VABM-L1-18W-G38-3
		4 valve positions	574469 VABM-L1-18W-G38-4
		5 valve positions	574470 VABM-L1-18W-G38-5
		6 valve positions	574471 VABM-L1-18W-G38-6
		7 valve positions	574472 VABM-L1-18W-G38-7
		8 valve positions	574473 VABM-L1-18W-G38-8
		9 valve positions	574474 VABM-L1-18W-G38-9
		10 valve positions	574475 VABM-L1-18W-G38-10
		12 valve positions	574476 VABM-L1-18W-G38-12
		14 valve positions	574477 VABM-L1-18W-G38-14
		16 valve positions	574478 VABM-L1-18W-G38-16

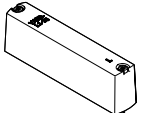
Ordering data

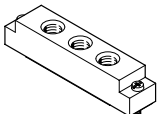
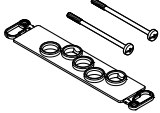
Ordering data – Accessories		Description	Part no.	Type
Cover plate <span style="float: right;">Data sheets → Internet: vabb</span>				
	For valve position on manifold rail, including screws and seal	★ 574482	VABB-L1-18	
Separator <span style="float: right;">Data sheets → Internet: vabd</span>				
	For creating pressure zones	574483	VABD-14-B	
Supply plate <span style="float: right;">Data sheets → Internet: vabf</span>				
	For valve position on manifold rail, including screws and seal	574481	VABF-L1-18-P3A4-G14	
Seals <span style="float: right;">Data sheets → Internet: vabd</span>				
	For sub-base valves G1/4	Delivery quantity: 10 sets (each with 2 screws and 1 seal)	574480	VABD-L1-18B-S-G14

 **Note**  
 Connect supply plate at port 1 with compressed air. Reverse operation (pressure at port 3, 5) is not permissible.

Festo core product range ★ Generally ready for dispatch from the factory within 24 hours  
★ Generally ready for dispatch from the factory within 5 days

Solenoid valves VUVG

E-boxes

General technical data							
Variants	H2	H3	S2	S3	L-	R1	R8
Mounting position	Any						
Electrical connection	2-pin, socket				Flying leads	M8 individual plug, 4-pin	M8 individual plug, 3-pin
Degree of protection	IP40					IP65	
Signal status display	LED						
Type of mounting	Clip					Self-tapping screw	
Note on materials	RoHS-compliant						
Housing colour	Black						
Information on housing materials	PA						
Certification	RCM						

Protective circuit without holding current reduction

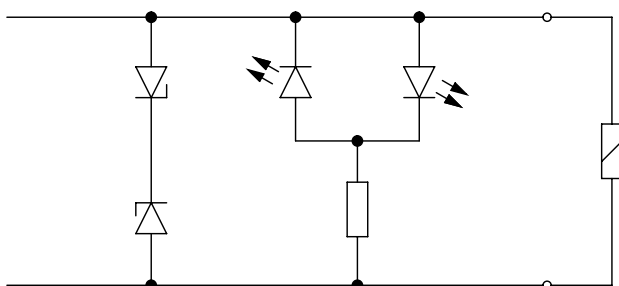

The solenoid coils (P type) of the 5, 12 and 24 V designs are equipped with a protective circuit to arrest sparks and protect against polarity reversal.

Protective circuit with holding current reduction

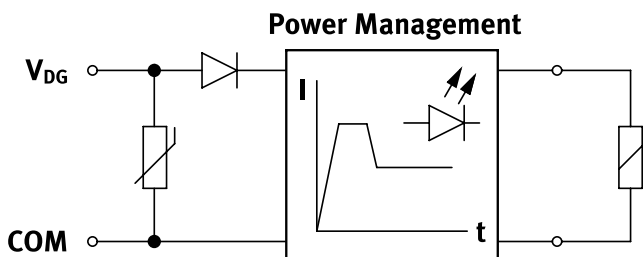

The 24 V DC design (R type) additionally features holding current reduction. This reduces the power from 1 W to 0.35 W.

Pin allocation for E-box

	Pin	Description	
<b>Rectangular plug, connection pattern H</b>			
	VAVE-L1-1VH2-LP, VAVE-L1-1VH3-LP		
	1	+ or -	Without holding current reduction
	2	+ or -	
	VAVE-L1-1H2-LR, VAVE-L1-1H3-LR		With holding current reduction
1	+		
2	-		
<b>Rectangular plug, connection pattern S</b>			
	VAVE-L1-1VS2-LP, VAVE-L1-1VS3-LP		
	1	+ or -	Without holding current reduction
	2	+ or -	
	VAVE-L1-1S2-LR, VAVE-L1-1S3-LR		With holding current reduction
1	-		
2	+		
<b>Flying leads, 2-pin</b>			
	VAVE-L1-1VL1...4-LP		
	1	+ or -	Without holding current reduction
	2	+ or -	
	VAVE-L1-1L1...4-LR		With holding current reduction
1	-		
2	+		

E-boxes

Pin allocation for E-box		Pin	Description
<b>Round plug, M8, 3-pin</b>			
	<b>VAVE-L1-1VR8-LP</b>		
	1	Not used	Without holding current reduction
	3	+ or -	
	4	+ or -	
	<b>VAVE-L1-1R8-LR</b>		
	1	Not used	With holding current reduction
3	+ or -		
4	+ or -		
<b>Round plug, M8, 4-pin</b>			
	<b>VAVE-L1-1VR1-LP</b>		
	1	Not used	Without holding current reduction
	2	Not used	
	3	+ or -	
	4	+ or -	
	<b>VAVE-L1-1R1-LR</b>		
	1	Not used	With holding current reduction
	2	Not used	
3	+ or -		
4	+ or -		
<b>Open cable end</b>			
	<b>VAVE-L1-1VK...</b>		
	BK	+ or -	Without holding current reduction
	BK	+ or -	
	<b>VAVE-L1-1K...</b>		
BK	+ or -	With holding current reduction	
BK	+ or -		

Solenoid valves VUVG

E-boxes

Dimensions

Download CAD data → [www.festo.com](http://www.festo.com)

E-boxes, S2/H2

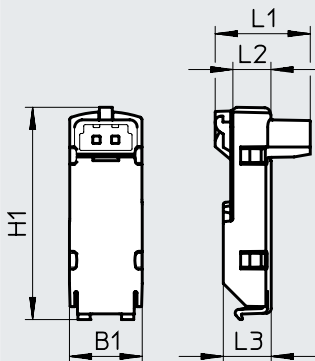

Type	B1	H1 ±0.5	L1	L2	L3
VAVE-L1-1VS2-LP	9.8	28.8	12.9	5.2	6.5
VAVE-L1-1S2-LR			10.8		
VAVE-L1-1VH2-LP					
VAVE-L1-H2-LR					

E-boxes, S3/H3

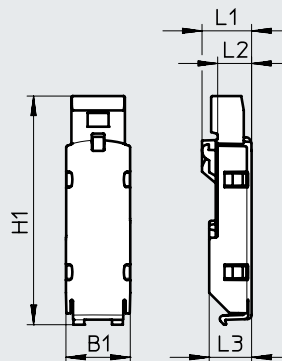

Type	B1	H1 ±0.5	L1	L2	L3
VAVE-L1-1VS3-LP	9.8	35	7.6	5.2	6.5
VAVE-L1-1S3-LR			33.6		
VAVE-L1-1VH3-LP					
VAVE-L1-1H3-LR					

Dimensions

Download CAD data → [www.festo.com](http://www.festo.com)

E-boxes, VL11 ... 1 4

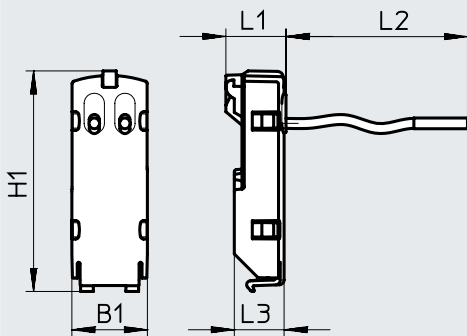

Type	B1	H1 ±0.5	L1	L2	L3
VAVE-L1-1VL1-LP	9.8	28.8	7.9	0.5	6.5
VAVE-L1-1L1-LR				1	
VAVE-L1-1VL2-LP					
VAVE-L1-1L2-LR				5	
VAVE-L1-1VL3-LP					
VAVE-L1-1L3-LR					
VAVE-L1-1VL4-LP					
VAVE-L1-1L4-LR					

E-boxes, VK6 ... 9

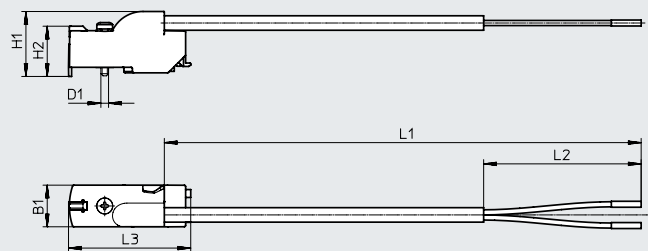

Type	B1	H1	H2 ±0.3	L1	L2 ±5	L3 ±0.5	D1 ∅
VAVE-L1-1VK6-LP	9.8	15.3	11.8	0.5	50	28.7	1.8
VAVE-L1-1VK7-LP				1.0			
VAVE-L1-1VK8-LP				2.5			
VAVE-L1-1VK9-LP				5.0			
VAVE-L1-1K6-LR				0.5			
VAVE-L1-1K7-LR				1.0			
VAVE-L1-1K8-LR				2.5			
VAVE-L1-1K9-LR				5.0			



E-boxes

Dimensions

Download CAD data → [www.festo.com](http://www.festo.com)

E-boxes, R8/R1

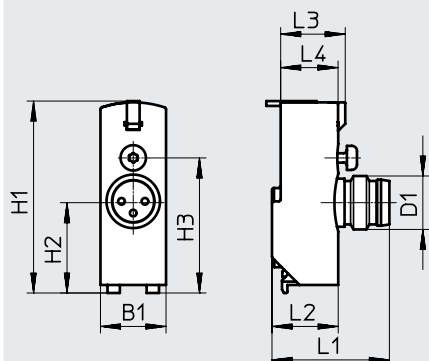

Type	B1	H1	H2	H3	L1	L2	L3	L4	D1 ∅
VAVE-L1-1VR8-LP	9.8	28.7	13.7	20.2	18.4	9.9	9.7	8.6	M 8
VAVE-L1-1VR1-LP									

Ordering data – E-boxes									
Design	Plug	Additional functions	Ambient temperature [°C]	Code	Power [W]	Voltage [V DC]	Part no.	Type	
	NEBV-H1 ...	Spark arresting, bipolar, IP40	-5 ... +50	H2	1	12/24	★ 566714	VAVE-L1-1VH2-LP	
		Spark arresting, holding current reduction, IP40	-5 ... +60	H2R	0.35	24	★ 566716	VAVE-L1-1H2-LR	
	NEBV-H1 ...	Spark arresting, bipolar, IP40	-5 ... +50	H3	1	12/24	566715	VAVE-L1-1VH3-LP	
		Spark arresting, holding current reduction, IP40	-5 ... +60	H3R	0.35	24	566717	VAVE-L1-1H3-LR	
	NEBV-HS ...	Spark arresting, bipolar, IP40	-5 ... +50	S2	1	12/24	566718	VAVE-L1-1VS2-LP	
		Spark arresting, holding current reduction, IP40	-5 ... +60	S2R	0.35	24	566720	VAVE-L1-1S2-LR	
	NEBV-HS ...	Spark arresting, bipolar, IP40	-5 ... +50	S3	1	12/24	566719	VAVE-L1-1VS3-LP	
		Spark arresting, holding current reduction, IP40	-5 ... +60	S3R	0.35	24	566721	VAVE-L1-1S3-LR	
	Open cable end	Spark arresting, bipolar, IP40	-5 ... +50	L1	1	12/24	566722	VAVE-L1-1VL1-LP	
				L2			566723	VAVE-L1-1VL2-LP	
				L3			566724	VAVE-L1-1VL3-LP	
				L4			566725	VAVE-L1-1VL4-LP	
		Spark arresting, holding current reduction, IP40	-5 ... +60	L1R	0.35	24	566726	VAVE-L1-1L1-LR	
				L2R			566727	VAVE-L1-1L2-LR	
				L3R			566728	VAVE-L1-1L3-LR	
				L4R			566729	VAVE-L1-1L4-LR	

Festo core product range



★ Generally ready for dispatch from the factory within 24 hours  
 ★ Generally ready for dispatch from the factory within 5 days

Solenoid valves VUVG

E-boxes

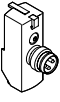
Ordering data – E-boxes										
Design	Plug	Additional functions	Ambient temperature [°C]	Code	Power	Voltage	Cable length	Part no.	Type	
					[W]	[V DC]	[m]			
	Open cable end	Spark arresting, bipolar, IP65	-5 ... +60	K6	1	12/24	0.5	573941	VAVE-L1-1VK6-LP	
				K7			1	★ 573942	VAVE-L1-1VK7-LP	
				K8			2.5	573943	VAVE-L1-1VK8-LP	
				K9			5	573944	VAVE-L1-1VK9-LP	
		Spark arresting, bipolar, holding current reduction, IP65	-5 ... +60	K6R	0.35	24	0.5	573945	VAVE-L1-1K6-LR	
							K7R	1	573946	VAVE-L1-1K7-LR
							K8R	2.5	573947	VAVE-L1-1K8-LR
							K9R	5	573948	VAVE-L1-1K9-LR
	NEBU-M8 ...	Spark arresting, bipolar, IP65	-5 ... +60	R8	1	12/24	-	★ 573919	VAVE-L1-1VR8-LP	
		Spark arresting, bipolar, holding current reduction, IP65		R8R	0.35	24	-	573920	VAVE-L1-1R8-LR	
		Spark arresting, bipolar, IP65		R1	1	12/24	-	573921	VAVE-L1-1VR1-LP	
		Spark arresting, bipolar, holding current reduction, IP65		R1R	0.35	24	-	573922	VAVE-L1-1R1-LR	

Festo core product range



Generally ready for dispatch from the factory within 24 hours

Generally ready for dispatch from the factory within 5 days

Accessories

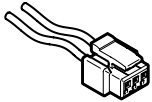
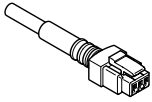
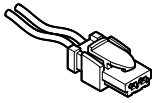
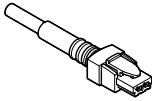
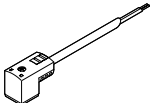
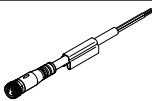
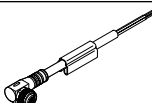
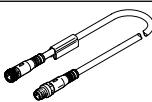
Ordering data	Description	Cable length [m]	Part no.	Type
<b>Plug socket with cable, not sheathed, open end</b> <span style="float:right">Data sheets → Internet: nebv</span>				
	For E-box code H2, H2R or H3, H3R, 2-pin socket	0.5	★ 566654	NEBV-H1G2-KN-0.5-N-LE2
		1	★ 566655	NEBV-H1G2-KN-1-N-LE2
		2.5	★ 566656	NEBV-H1G2-KN-2.5-N-LE2
		5	566657	NEBV-H1G2-KN-5-N-LE2
<b>Plug socket with cable, sheathed, open end</b> <span style="float:right">Data sheets → Internet: nebv</span>				
	For E-box code H2, H2R or H3, H3R, 2-pin socket	0.5	★ 566658	NEBV-H1G2-P-0.5-N-LE2
		1	★ 566659	NEBV-H1G2-P-1-N-LE2
		2.5	★ 566660	NEBV-H1G2-P-2.5-N-LE2
		5	566661	NEBV-H1G2-P-5-N-LE2
<b>Plug socket with cable, not sheathed, open end</b> <span style="float:right">Data sheets → Internet: nebv</span>				
	For E-box code S2, S2R or S3, S3R, 2-pin socket	0.5	566662	NEBV-HSG2-KN-0.5-N-LE2
		1	566663	NEBV-HSG2-KN-1-N-LE2
		2.5	566664	NEBV-HSG2-KN-2.5-N-LE2
		5	566665	NEBV-HSG2-KN-5-N-LE2
<b>Plug socket with cable, sheathed, open end</b> <span style="float:right">Data sheets → Internet: nebv</span>				
	For E-box code S2, S2R or S3, S3R, 2-pin socket	0.5	566666	NEBV-HSG2-P-0.5-N-LE2
		1	566667	NEBV-HSG2-P-1-N-LE2
		2.5	566668	NEBV-HSG2-P-2.5-N-LE2
		5	566669	NEBV-HSG2-P-5-N-LE2
<b>Connecting cable, open end</b>				
	For pilot valve VSCS to ISO 15218, narrow socket, type C to EN 175301-803	2.5	8032623	NEBV-C1SW2L-P-K-2.5-N-LE2-S9
		5	8032626	NEBV-C1SW2L-P-K-5-N-LE2-S9
		10	8032627	NEBV-C1SW2L-P-K-10-N-LE2-S9
		2.5	8032628	NEBV-C1SW3-K-2.5-N-LE3-S9
		5	8032629	NEBV-C1SW3-K-5-N-LE3-S9
<b>Connecting cable, open end</b> <span style="float:right">Data sheets → Internet: nebu</span>				
	For E-box code R8 3-pin, straight socket, M8x1	2.5	★ 541333	NEBU-M8G3-K-2.5-LE3
		5	★ 541334	NEBU-M8G3-K-5-LE3
	For E-box code R1 4-pin, straight socket, M8x1	2.5	541342	NEBU-M8G4-K-2.5-LE4
		5	541343	NEBU-M8G4-K-5-LE4
<b>Connecting cable, open end</b> <span style="float:right">Data sheets → Internet: nebu</span>				
	For E-box code R8 3-pin, angled socket, M8x1	2.5	★ 541338	NEBU-M8W3-K-2.5-LE3
		5	★ 541341	NEBU-M8W3-K-5-LE3
	For E-box code R1 4-pin, angled socket, M8x1	2.5	541344	NEBU-M8W4-K-2.5-LE4
		5	541345	NEBU-M8W4-K-5-LE4
<b>Connecting cable</b> <span style="float:right">Data sheets → Internet: nebu</span>				
	For E-box code R8 3-pin, straight socket, M8x1	0.5	★ 541346	NEBU-M8G3-K-0.5-M8G3
		1	★ 541347	NEBU-M8G3-K-1-M8G3
		2.5	★ 541348	NEBU-M8G3-K-2.5-M8G3
		5	★ 541349	NEBU-M8G3-K-5-M8G3
		10	569844	NEBU-M8G3-K-10-M8G3
	For E-box code R1 4-pin, straight socket, M8x1	2.5	554035	NEBU-M8G4-K-2.5-M8G4





Festo core product range

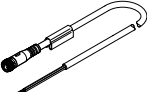
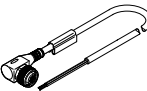

Generally ready for dispatch from the factory within 24 hours  
Generally ready for dispatch from the factory within 5 days

Solenoid valves VUVG

Accessories

Ordering data		Description	Part no.	Type	PU1)	
<b>Connecting cable, open end</b>						
	For pilot valve VSCS to ISO 15218, straight socket, M12x1, A-coded to EN 61076-2-101	2.5 m long	541363	NEBU-M12G5-K-2.5-LE3		
		5 m long	541364	NEBU-M12G5-K-5-LE3		
	For pilot valve VSCS to ISO 15218, angled socket, M12x1, A-coded to EN 61076-2-101	2.5 m long	541367	NEBU-M12W5-K-2.5-LE3		
		5 m long	541370	NEBU-M12W5-K-5-LE3		
<b>Blanking plug</b> <span style="float: right;">Data sheets → Internet: b</span>						
	For manifold rail and valve	M5 thread	★ 3843	B-M5	10	
		M7 thread	★ 174309	B-M7	10	
	For manifold rail	G1/8 thread	★ 3568	B-1/8	10	
		G1/4 thread	★ 3569	B-1/4	10	
		G3/8 thread	★ 3570	B-3/8	10	
	For valve	G1/8 thread	578406	NPQH-BK-G18-P10	10	
		G1/4 thread	578407	NPQH-BK-G14-P10	10	
<b>Reducing nipple</b>						
	Male thread M7	Female thread M5	161359	D-M5I-M7A-ISK	10	
<b>Fittings</b> <span style="float: right;">Data sheets → Internet: qsm</span>						
	M3 thread	For tubing Ø 3 mm	Round releasing ring	133001	QSM-M3-3-I-R	10
		For tubing Ø 4 mm	Round releasing ring	133002	QSM-M3-4-I-R	10
	M5 thread	For tubing Ø 3 mm	Round releasing ring	133003	QSM-M5-3-I-R	10
			Oval releasing ring	153313	QSM-M5-3-I	10
		For tubing Ø 4 mm	Round releasing ring	133004	QSM-M5-4-I-R	10
			Oval releasing ring	★ 153315	QSM-M5-4-I	10
		For tubing Ø 6 mm	Round releasing ring	133005	QSM-M5-6-I-R	10
			Oval releasing ring	★ 153317	QSM-M5-6-I	10
	M7 thread	For tubing Ø 4 mm	Oval releasing ring	★ 153319	QSM-M7-4-I	10
		For tubing Ø 6 mm	Round releasing ring	133007	QSM-M7-6-I-R	10
	G1/8 thread	For tubing Ø 4 mm	Oval releasing ring	★ 153321	QSM-M7-6-I	10
			Oval releasing ring	★ 186106	QS-G1/8-4-I	10
		For tubing Ø 6 mm	Oval releasing ring	★ 186107	QS-G1/8-6-I	10
		For tubing Ø 8 mm	Oval releasing ring	★ 186109	QS-G1/8-8-I	10
	G1/4 thread	For tubing Ø 8 mm	Oval releasing ring	★ 132999	QS-G1/8-10-I	10
			Oval releasing ring	★ 186108	QS-G1/4-6-I	10
		For tubing Ø 6 mm	Oval releasing ring	130677	QS-1/4-6-100	100
			Oval releasing ring	★ 186110	QS-G1/4-8-I	10
	R3/8 thread	For tubing Ø 8 mm	Oval releasing ring	★ 153016	QS-1/4-8-I	10
			Oval releasing ring	★ 186112	QS-G1/4-10-I	10
		For tubing Ø 10 mm	Oval releasing ring	★ 153018	QS-1/4-10-I	10
			Oval releasing ring	130681	QS-3/8-8-50	50
	R3/8 thread	For tubing Ø 8 mm	Oval releasing ring	130682	QS-3/8-10-50	50
		For tubing Ø 10 mm	Oval releasing ring	130683	QS-3/8-12-20	20
For tubing Ø 12 mm		Oval releasing ring	164957	QS-3/8-16	1	
For tubing Ø 16 mm		Oval releasing ring				

1) Packaging unit.

Festo core product range







Generally ready for dispatch from the factory within 24 hours

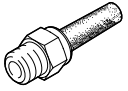
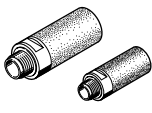
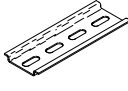
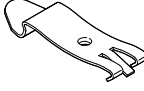

Generally ready for dispatch from the factory within 5 days

Accessories

Ordering data		Description	Part no.	Type	PU1)
Silencer <span style="float: right;">Data sheets → Internet: amte</span>					
	For M3 thread		1231120	AMTE-M-LH-M3	20
	For M5 thread		★ 1205858	AMTE-M-LH-M5	20
	For M7 thread		161418	UC-M7	1
	For G1/8 thread	High flow rate	★ 2307	U-1/8	1
		Lower flow rate	161419	UC-1/8	1
	For G1/4 thread	High flow rate	★ 2316	U-1/4	1
		Lower flow rate	165004	UC-1/4	1
	For G3/8 thread	High flow rate	★ 2309	U-3/8	1
		Lower flow rate	1707427	UC-3/8	1
	Metal housing	★ 6843	U-3/8-B	1	
H-rail <span style="float: right;">Data sheets → Internet: nrh</span>					
	To EN 60715, 35 x 7.5 (WxH)	Length 2 m	35430	NRH-35-2000	1
H-rail mounting <span style="float: right;">Data sheets → Internet: vame</span>					
	-		★ 569998	VAME-T-M4	2
Cover cap for manual override					
	Covered		540898	VMPA-HBV-B	10
	Non-detenting		540897	VMPA-HBT-B	10
	Detenting (without accessories)		8002234	VAMC-L1-CD	10
Identification holder <span style="float: right;">Data sheets → Internet: aslr</span>					
	Holder for an inscription label and cover for the retaining screw and manual override		570818	ASLR-D-L1	10

1) Packaging unit.

Festo core product range







Generally ready for dispatch from the factory within 24 hours



Generally ready for dispatch from the factory within 5 days

Solenoid valves VUVG

Accessories

Ordering data		Description	Part no.	Type	PU <sup>1)</sup>	
<b>Check valve</b>						
	For manifold rails VABM-L1-10...	For blocking the flow in the event of back pressure in duct 3 and 5	8047364	VABF-L1-10H-H2	10	
	For manifold rails VABM-L1-14...		8047365	VABF-L1-14-H2	10	
<b>Flow restrictor</b>						
	For manifold rails VABM-L1-10...	For setting the flow rate during pressurisation and exhausting (for threaded connection M5)	Nominal size: 0.5 mm	8025709	VFFG-T-M5-5	10
			Nominal size: 0.6 mm	8025710	VFFG-T-M5-6	10
			Nominal size: 0.7 mm	8025711	VFFG-T-M5-7	10
			Nominal size: 0.85 mm	8025712	VFFG-T-M5-8	10
			Nominal size: 1.05 mm	8025713	VFFG-T-M5-10	10
			Nominal size: 1.2 mm	8025714	VFFG-T-M5-12	10
		For setting the flow rate for pressurisation and exhausting (for $\varnothing$ 4 mm)	Nominal size: 0.5 mm	8047346	VFFG-T-F4-5	10
			Nominal size: 0.6 mm	8047347	VFFG-T-F4-6	10
			Nominal size: 0.7 mm	8047348	VFFG-T-F4-7	10
			Nominal size: 0.85 mm	8047349	VFFG-T-F4-8	10
			Nominal size: 1.05 mm	8047350	VFFG-T-F4-10	10
			Nominal size: 1.2 mm	8047351	VFFG-T-F4-12	10
	For manifold rails VABM-L1-14...	For setting the flow rate for pressurisation and exhausting (for $\varnothing$ 5.8 mm)	Nominal size: 1.55 mm	8047352	VFFG-T-F4-15	10
			Nominal size: 0.7 mm	8047353	VFFG-T-F6-7	10
			Nominal size: 0.85 mm	8047354	VFFG-T-F6-8	10
			Nominal size: 1.05 mm	8047355	VFFG-T-F6-10	10
			Nominal size: 1.15 mm	8047356	VFFG-T-F6-11	10
			Nominal size: 1.4 mm	8047357	VFFG-T-F6-14	10
			Nominal size: 1.6 mm	8047358	VFFG-T-F6-16	10
			Nominal size: 1.8 mm	8047359	VFFG-T-F6-18	10
			Nominal size: 1.8 mm	8047359	VFFG-T-F6-18	10
<b>Flow control set</b>						
	For manifold rails VABM-L1-10...	Two of each size, for threaded connection M5	8025716	VFFG-T-M5-A-V1	14	
		Two of each size, for $\varnothing$ 4 mm	8062200	VFFG-T-F4-A-V1	14	
	For manifold rails VABM-L1-14...	Two of each size, for $\varnothing$ 5.8 mm	8062201	VFFG-T-F6-A-V1	14	

1) Packaging unit.

Characteristics

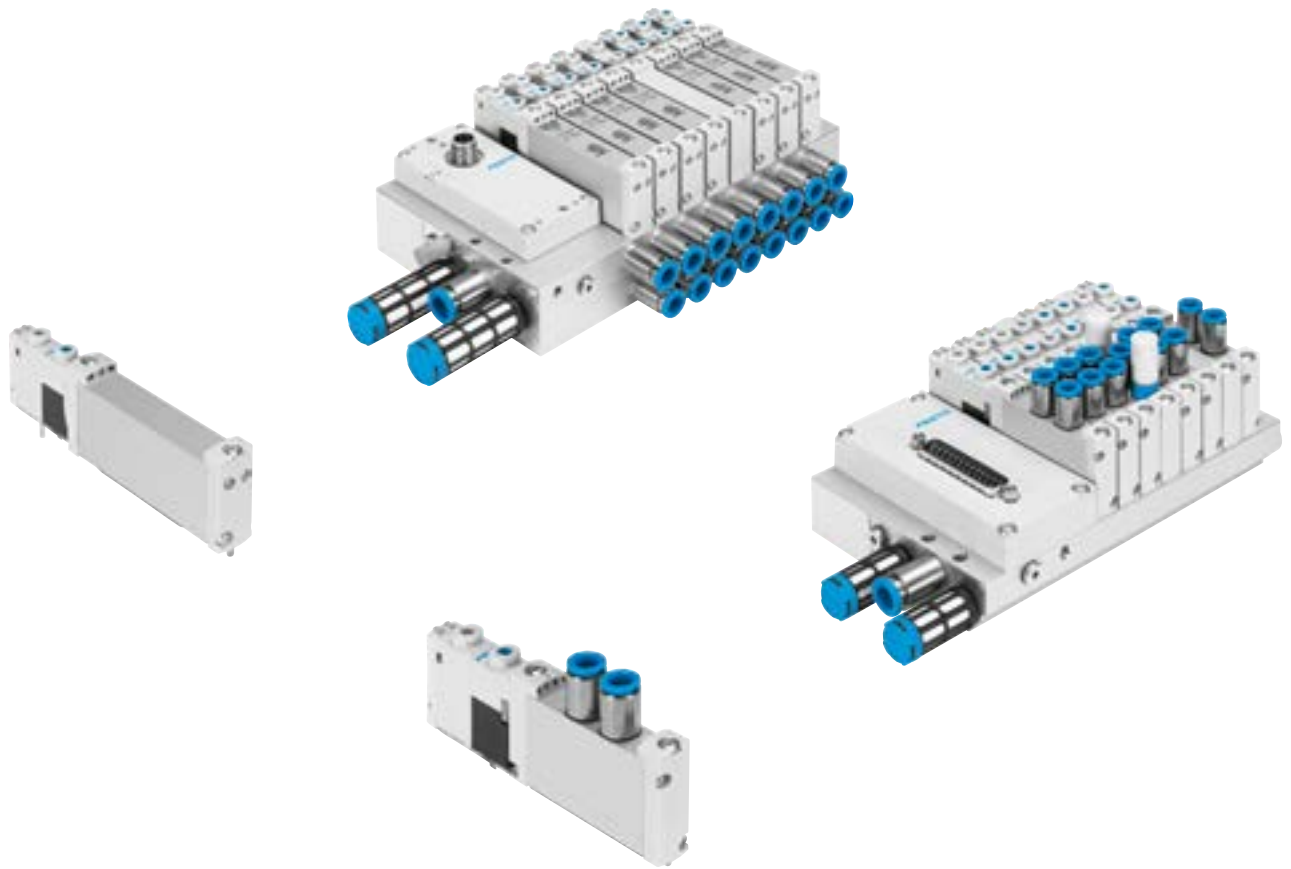

**Innovative**

- Festo-specific I-Port interface for bus nodes (CTEU)
- IO-Link mode for direct connection to a higher-level IO-Link master
- Festo-specific I-Port interface with interlock
- Variable multi-pin plug connection using Sub-D or ribbon cable
- Reversible piston spool valves, up to 24 valve positions
- Reduced power consumption
- Excellent price/performance ratio

**Flexible**

- Choice of quick plug connectors
- Multiple pressure zones possible
- Sub-D variant and fieldbus interface rated to IP67
- Internal or external pilot air with the same manifold rail possible through the use of blanking plugs
- Sub-base valves with working ports underneath for installation in control cabinets

**Reliable**

- Sturdy and durable metal components
  - Valves
  - Manifold rails
- Fast troubleshooting thanks to LED display
- Manual override: choose from non-detenting, detenting or covered

**Easy to install**

- Easy mounting thanks to captive screws and seal
- Connection technology easy to change
- Inscription label holder for labelling

**Valve terminal configurator**

A valve terminal configurator is available to help you select a suitable valve terminal VTUG. This makes it much easier to order the right product.

Valve terminals VTUG are ordered via an ident. code. All valve terminals are supplied fully assembled and individually tested.

This reduces assembly and installation time to a minimum.

Download CAD data → [www.festo.com](http://www.festo.com)

Ordering system for valve terminal VTUG  
→ Internet: vtug

Valve terminal VTUG with multi-pin plug connection and fieldbus interface

Characteristics

**Sub-base and semi in-line valves for valve terminal VTUG**

VUVG-S...1T1, semi in-line valve

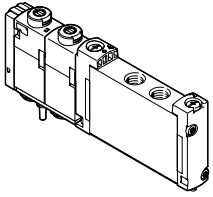

The supply ports (1, 3 and 5) of semi in-line valves are connected to the valve by a pneumatic link (e.g. sub-base). The working ports (2, 4) are on the valve.

Valve terminal VTUG with variable electrical connection

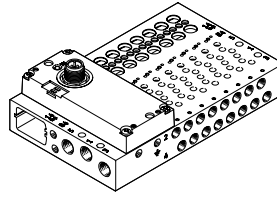

VUVG-B...1T1, sub-base valve

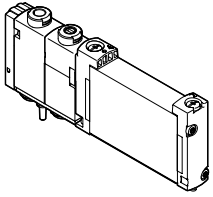

The supply ports (1, 3 and 5) and the working ports (2, 4) of sub-base valves are connected to the valve by a pneumatic link (e.g. sub-base).

**Overview – Valve terminal with multi-pin plug connection and fieldbus interface**

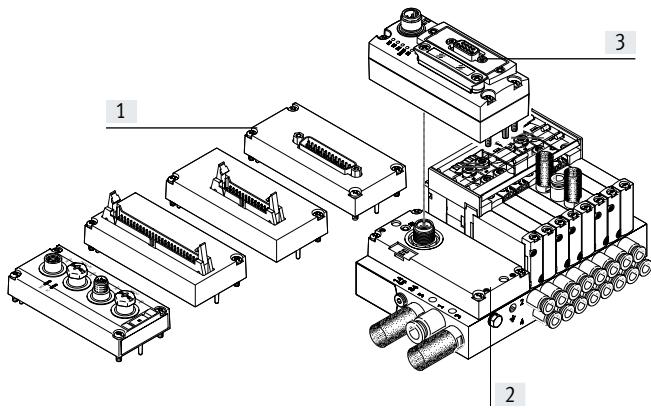

Variable electrical connection:

- [1] Ribbon cable or Sub-D
- [2] I-Port interface
- [3] CTEU bus node

**Overview – Valve terminal with interlock**

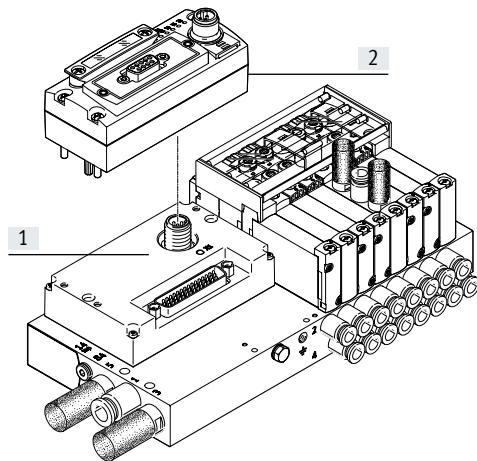

Variable electrical connection:

- [1] I-Port interface with interlock
- [2] CTEU bus node



## Characteristics

### Equipment options

#### Valve functions

- 2x 3/2-way, 3/2-way, 5/2-way, 5/3-way valves
- Reversible piston spool valves, up to 24 valve positions

#### Electrical connection options

- IO-Link mode for direct connection to a higher-level IO-Link master
- Festo-specific I-Port interface for bus nodes (CTEU)
- Variable multi-pin plug connection using Sub-D or ribbon cable
- Festo-specific I-Port interface with interlock (for valves of size 10 mm)

### Basic valves VUVG

#### Size

- 10
- 14
- 18

#### Variants

- Semi in-line valve
- Sub-base valve

### Valve functions

#### 3/2-way valve

- Single solenoid
- Normally open
- Normally closed

#### 2x 3/2-way valve

- Single solenoid
- Normally open
- Normally closed
- 1x normally closed, 1x normally open
- Mechanical spring
- Pneumatic spring

#### 5/2-way valve

- Single solenoid
- Pneumatic/mechanical spring
- Mechanical spring
- Pneumatic spring
- Double solenoid valve

#### 5/3-way valve

- Mid-position pressurised
- Mid-position exhausted
- Mid-position closed

### Cover caps for manual override

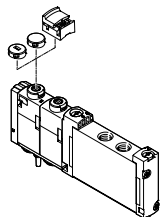

- Closed cover cap, covered manual override
- Slotted cover cap, non-detenting manual override
- Cover cap for detenting actuation without tools

### Identification holder

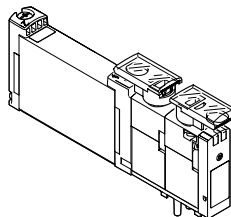

Inscription label holder ASLR-D-L1 for identifying the valves and as a cover for the manual override.

### Inscription label holder

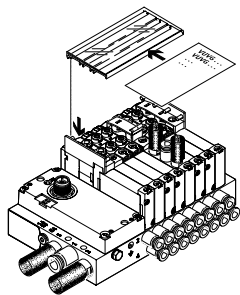

Inscription label holder ASCF-H-L1... for identifying the valves on the valve terminal VTUG

Valve terminal VTUG with multi-pin plug connection and fieldbus interface

Characteristics – Pneumatic components

**Manifold rail**

For semi in-line valves

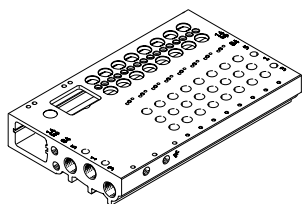

The semi in-line valves are supplied with external pilot air. The pilot air is set via the manifold rail. The scope of delivery of the manifold rail includes a short and a long blanking plug for setting the pilot air.

- For semi in-line valves M5/M7 (size 10), G1/8 (size 14) and G1/4 (size 18)
- For 2x 3/2-way, 5/2-way and 5/3-way valves
- 4 to 24 valve positions with electrical interlinking

For sub-base valves

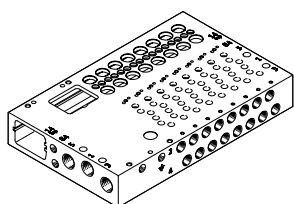

The sub-base valves are supplied with external pilot air. The pilot air is set via the manifold rail. The scope of delivery of the manifold rail includes a short and a long blanking plug for setting the pilot air.

- For sub-base valves M5/M7 (size 10), G1/8 (size 14) and G1/4 (size 18)
- For 2x 3/2-way, 3/2-way, 5/2-way and 5/3-way valves
- 4 to 24 valve positions with electrical interlinking

Long version

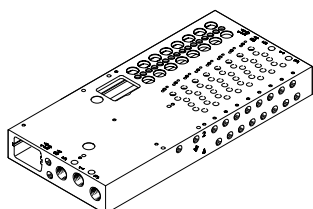

Versions:

- I-Port interface with lateral outlet orientation: for semi in-line valves and sub-base valves M5/M7 (size 10), G1/8 (size 14) and G1/4 (size 18)

- Interlock: For sub-base and semi in-line valves M5/M7 (size 10)

For control cabinet installation, outlet orientation underneath (U)

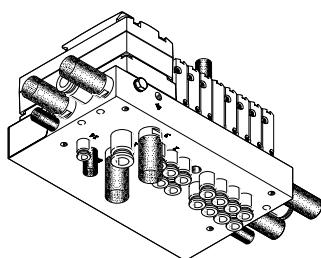

For sub-base valves M7 (size 10), G1/8 (size 14) and G1/4 (size 18).

For control cabinet installation, outlet orientation front (FD)

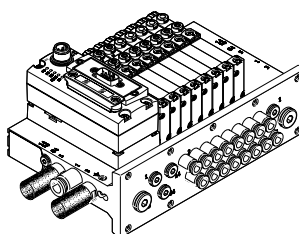

For sub-base valves M7 (size 10) and G1/8 (size 14).

For control cabinet installation with shut-off function (hot swap)

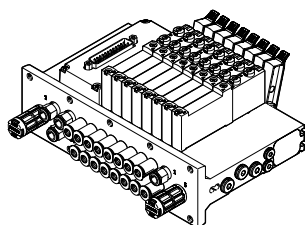

Shut-off function for duct 1, for sub-base valves M7 (size 10) and G1/8 (size 14):

- Internal pilot air supply only
- Vacuum operation not possible

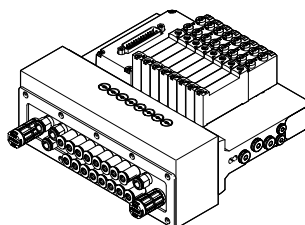

Shut-off function for duct 2 and 4, for sub-base valves M7 (size 10) and G1/8 (size 14):

- Internal/external pilot air supply
- Vacuum operation not possible

**Note**

Pressurisation and exhaust at both ends is recommended for an optimised flow rate in cases where multiple valves switch simultaneously.

## Characteristics

### Electrical connection

#### Multi-pin plug connection

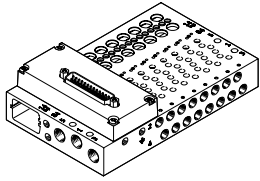

The signals are transmitted from the controller to the valve terminal via a pre-assembled or self-assembled multi-wire cable to the multi-pin plug connection.

This substantially reduces installation time compared to individually connected valves. The valve terminal can be equipped with max. 48 solenoid coils.

Versions:

- Sub-D connection
- Ribbon cable

#### I-Port interface

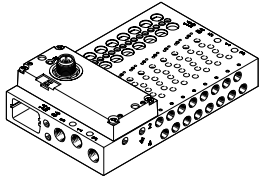

Festo-specific interface as a basis for bus nodes (CTEU) or in IO-Link mode for direct connection to a higher-level IO-Link master.

Communication and power supply take place via a common M12 interface.

Connectivity options:

- As I-Port interface for bus nodes (CTEU)
- In IO-Link mode for direct connection to an IO-Link master

#### I-Port interface with interlock

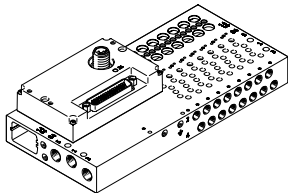

The interlock function enables the first 16 solenoid coils to be individually supplied externally.

The external supply guarantees safety-related release of these valves.

 **Note**  
The VTUG variant with multi-pin plug connection and fieldbus interface offers the additional option of individual electrical actuation of the valves (→ page 133).

### Supply plate

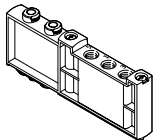

For additional air supply and exhaust via a valve position

 **Note**  
The supply plate VABF-L1-14-P3A4-G18-T1 can only be used with G fittings. R fittings are not permissible.

### Cover plate for vacant position

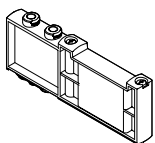

Vacant position cover

### Separator for pressure zones



For creating multiple pressure zones in a valve terminal

Characteristics – Pneumatic components

Creating pressure zones and separating exhaust air

Compressed air is supplied and exhausted via the manifold rail and via supply plates.

The position of the supply plates and duct separations can be freely selected with the VTUG.

A pressure zone is created by separating the internal supply ducts using a separator.

Pressure zone separation can be used for the following ducts:

- Duct 1
- Duct 3
- Duct 5

- Note**
- Use a separator if the exhaust air pressures are high
  - Use at least one supply plate/ supply for each pressure zone
  - Pressure zone separation is not possible in duct 12/14 (pilot air supply)

Duct separation	Description						
	<p>Pressure zones can be freely configured with the VTUG. The following duct separations are possible:</p> <table border="1"> <tr> <td data-bbox="802 801 1134 898">Duct 1 closed</td> <td data-bbox="1142 801 1334 898"> </td> </tr> <tr> <td data-bbox="802 909 1134 1005">Duct 1, 3, 5 closed</td> <td data-bbox="1142 909 1334 1005"> </td> </tr> <tr> <td data-bbox="802 1016 1134 1093">Duct 3, 5 closed</td> <td data-bbox="1142 1016 1334 1093"> </td> </tr> </table>	Duct 1 closed		Duct 1, 3, 5 closed		Duct 3, 5 closed	
Duct 1 closed							
Duct 1, 3, 5 closed							
Duct 3, 5 closed							
	<p>With the VTUG, the number of pressure zones is limited only by the number of valve positions on the manifold rail. Note that each supply plate occupies one valve position.</p>						

Separator VABD

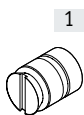
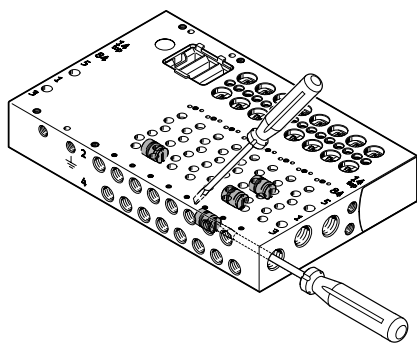

[1] Separator VABD

- Note**
- With the VTUG, several pressure zones can be created by fitting separators (VABD). The separators are inserted in the manifold rail using a slotted screwdriver.

Characteristics – Pneumatic components

**Shut-off function (hot swap)**

For duct 1

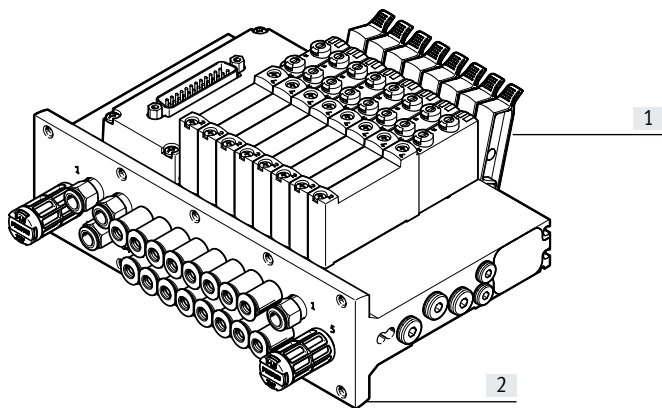

- [1] Actuating lever
- [2] Manifold rail with shut-off plate

The shut-off plate is located below the manifold block. Actuating the lever:

- disconnects the valve from the compressed air supply (duct 1)
- exhausts the pilot air supply on the valve side (duct 12 and 14)

The actuating levers can be individually locked in place, securing them against unwanted actuation.

For duct 2 and 4

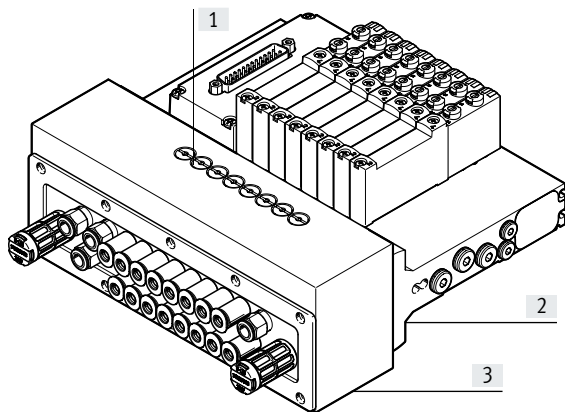

- [1] Plunger
- [2] Manifold rail
- [3] Manifold block

To actuate, press in the plunger with a pointed object or screwdriver and then turn clockwise through 90° until the stop is reached:

- Connection from the valve to ports 2 and 4 is blocked
- No exhaust of components connected at ports 2 and 4

**Pilot air supply**

Internal pilot air supply

Internal pilot air supply can be chosen with an operating pressure in the range 1.5 ... 8 bar, 2.5 ... 8 bar, or 3 ... 8 bar (depending on the valve used).

The pilot air supply is branched from duct 1 (compressed air supply) using an internal connection.

External pilot air supply

External pilot air supply is required for vacuum operation or operating pressures above 8 bar. The port for external pilot air supply (port 12/14) is located on the manifold rail.

Pilot exhaust air

The pilot air is exhausted via duct 82/84 of the manifold rail.

Pilot air supply

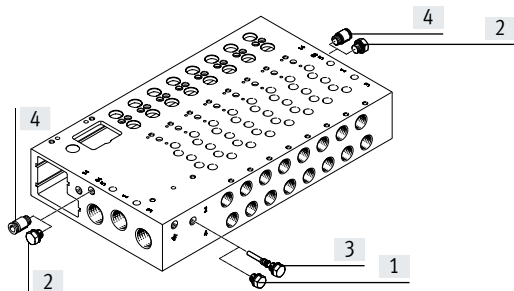

- [1] Blanking plug, short, with internal pilot air
- [2] Blanking plug for duct 12/14 with internal pilot air
- [3] Blanking plug, long, with external pilot air
- [4] Push-in fitting in duct 12/14 with external pilot air

The manifold rails have an internal connection between duct 12/14 and duct 1. To switch between internal and external pilot air, a blanking plug can be inserted into this connection.

Characteristics – Pneumatic components

Exhaust functions

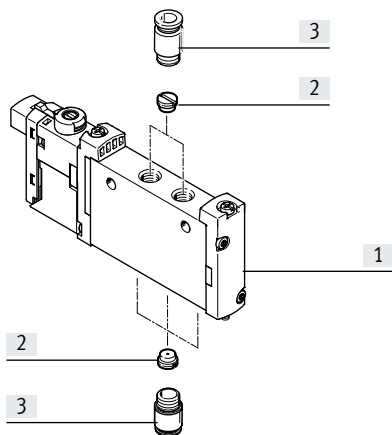

Flow restrictor for thread M5

Semi in-line valve, individual electrical connection: flow restrictor can be fitted in port 1, 3, 5 and/or in port 2, 4.

Sub-base valve, individual electrical connection: flow restrictor can be fitted in port 2, 4.

Fixed flow restrictor, self-tapping

The fixed flow restrictor can be used to permanently set the exhaust flow rate in ducts 3 and 5.

The fixed flow restrictors are screwed into ducts 3 and 5 in the manifold rail.

Please see the relevant assembly instructions:

→ [www.festo.com/sp](http://www.festo.com/sp)

Check valve

Check valves block the flow towards the valves if back pressure develops in ducts 3 and 5 in the case of a high exhaust capacity, thereby preventing actuators from switching unexpectedly. The check valves are screwed into ducts 3 and 5 in the manifold rail. Please see the relevant assembly instructions:

→ [www.festo.com/sp](http://www.festo.com/sp)

**Note**

- It is not possible to use a check valve and a fixed flow restrictor (in the same duct) at the same time.
- When screwing in again, use the threads already present.

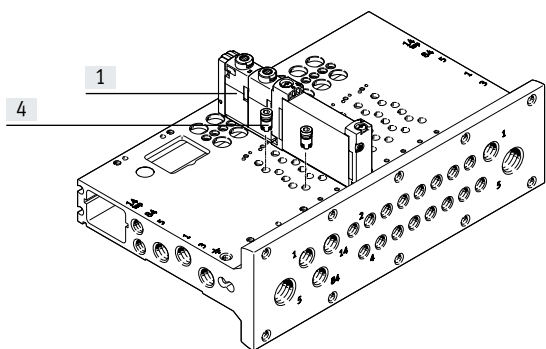

- [1] Valves VUVG
- [2] Flow restrictor for thread M5
- [3] Fitting
- [4] Fixed flow restrictor, self-tapping/check valve

## Characteristics – Pneumatic components

### Operation with different pressures

#### Vacuum operation

#### Points to note with 3/2-way valves with pneumatic spring return:

The 3/2-way valves are available in a design with two valves in one valve body and with pneumatic spring return. With these valves, the force for the return movement is obtained from port 1.

Vacuum operation is only possible at port 3 and 5, not at port 1. With external pilot air supply, vacuum can be connected at port 1, 3, 5 of the 5/2-way and 5/3-way valves.

Vacuum operation not possible when using the shut-off function (hot swap).

#### Reverse operation

The 3/2-way valves with pneumatic spring are not suitable for reverse operation, since at least the minimum pilot pressure must be present in duct 1.

 **Note**

Pressure must be present at port 1.

#### Pressure deflector (internal pilot air)

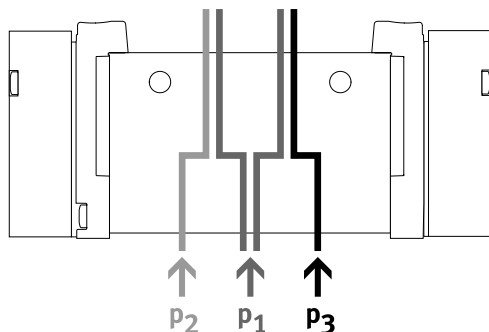

- Two different pressures are required
- Different pressures can be connected at duct 1, 3 and 5

#### Advantages

Any pressure or vacuum can be connected at duct 3 and 5 both with external and internal pilot air

 **Note**

- With internal pilot air, adhere to the minimum pilot pressure in duct 1
- With 2x 3/2-way valves without spring return, adhere to minimum pilot pressure in duct 1

#### Vacuum, ejector pulse and normal position

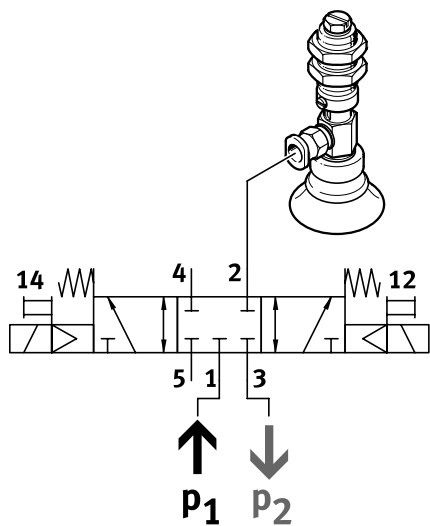

Vacuum, ejector pulse and normal position with internal pilot air can be achieved by connecting vacuum at duct 3 and pressure for the ejector pulse at duct 1.

## Valve terminal VTUG with multi-pin plug connection and fieldbus interface

### Characteristics – Pneumatics

#### Standard nominal flow rate $q_{nN}$ as a function of the number of switched valves $n$

Size 10 mm, 5/2-way valves

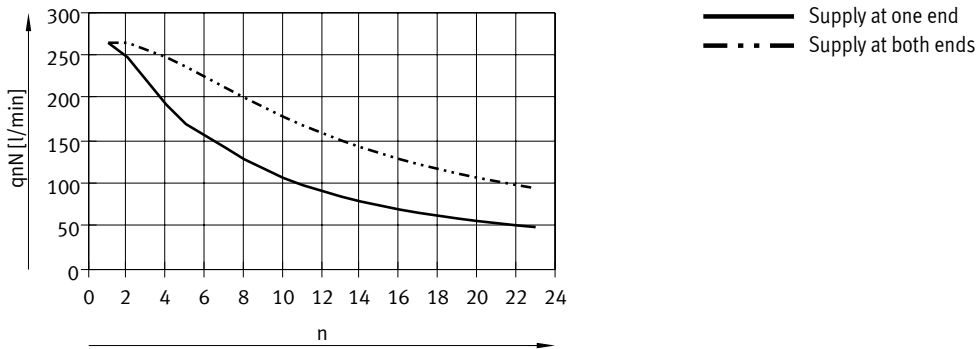

Size 14 mm

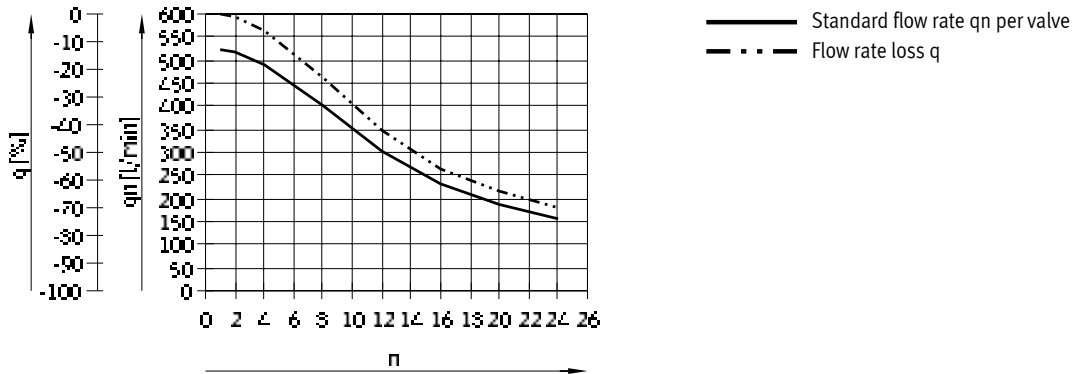

Size 18 mm

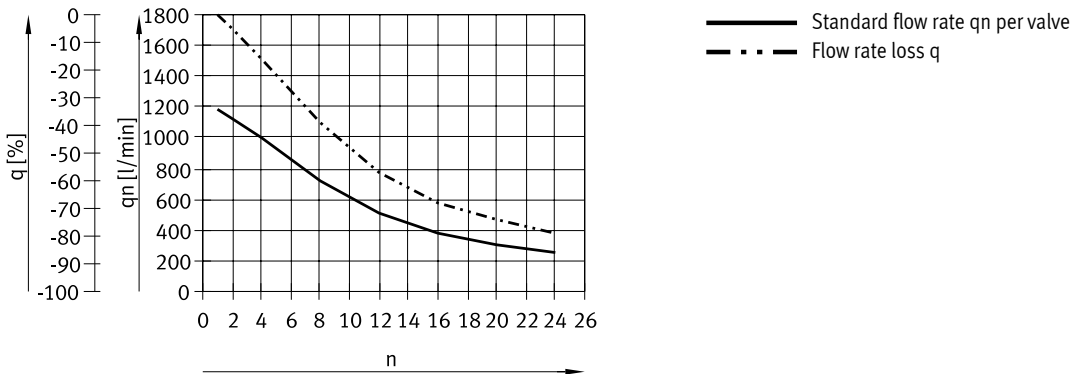



Characteristics – Pneumatics

**Pilot pressure p2 as a function of operating pressure p1**

2x 3/2-way valve, reset method: mechanical spring

2x 3/2-way valve, reset method: pneumatic spring

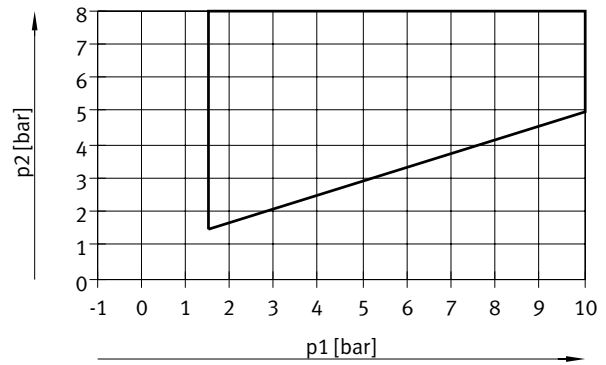
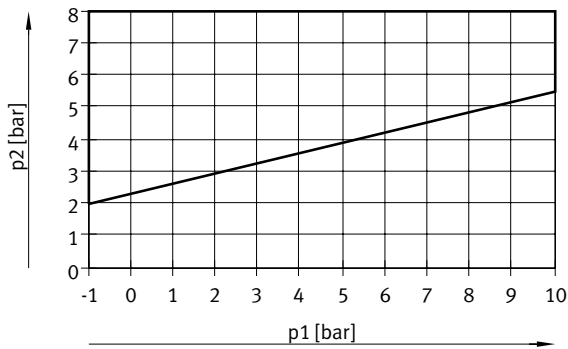

3/2-way single solenoid valve and 5/2-way single solenoid valve

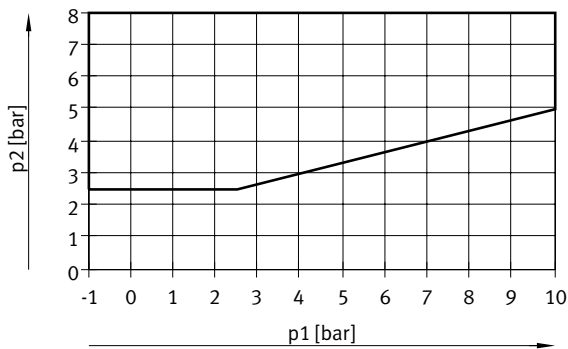

## Characteristics – Mounting

### Valve terminal mounting

Sturdy terminal mounting via:

- Four through-holes for wall mounting
- H-rail mounting



**Note**

Use the thread M5 provided on the manifold block for earthing the valve terminal.

### Wall mounting

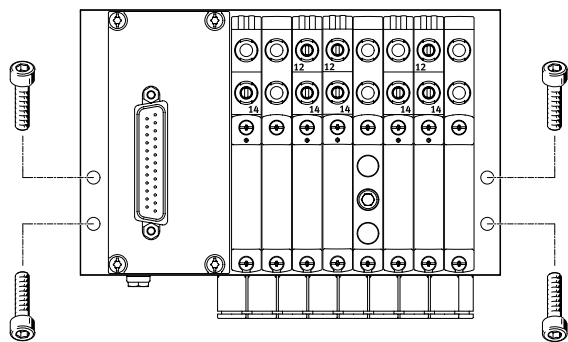

Screw the valve terminal VTUG onto the mounting surface using four M4 screws.

The mounting holes are on the left and right side of the manifold rail.

### H-rail mounting

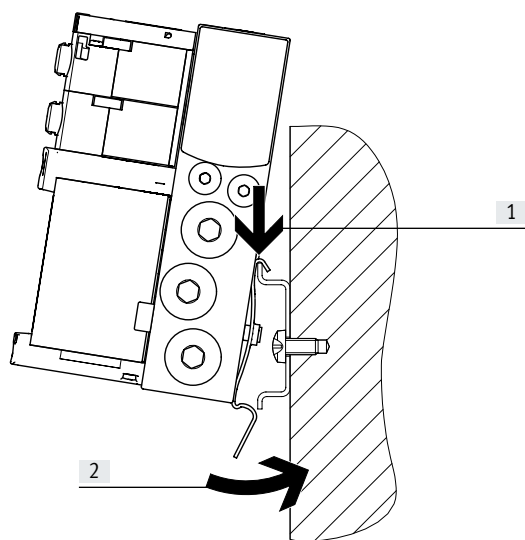

Attach the valve terminal VTUG to the H-rail (see arrow [1]).

Swivel the valve terminal onto the H-rail and secure in place with the clamping element (see arrow [2]).

Attach the manifold rails to a rail of type TH35 to EN 60715 using the H-rail mounting kit VAME-T-M4.

Use the following screws (to DIN 912) for mounting:

- Size 10: M4x30
- Size 14: M4x40
- Size 18: M5x50



**Note**

Permissible use of the H-rail:

- Manifold rail with outlet on the side or on top.
  - H-rail exclusively for horizontal mounting.
  - Vibration/shock loads are not permissible for this type of mounting.
- Size 14:
- Use H-rail of type TH35-7.5 for valve terminals with a maximum of 8 valve positions.
  - Use H-rail of type TH35-15 for mounting in accordance with the standard and for more than 8 valve positions.

## Characteristics – Mounting

### Manual override (MO)

#### MO with automatic return (non-detenting)

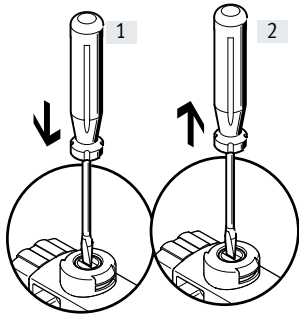

- [1] Press in the plunger of the MO with a pointed object or screwdriver. The pilot valve switches and actuates the main valve.
- [2] Remove the pointed object or screwdriver. The spring force pushes the plunger of the MO back. Pilot valve returns to its initial position as does the single solenoid main valve (not the case with double solenoid valve code J).

#### MO with lock (detenting)

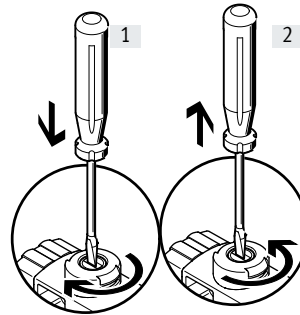

- [1] Press in the plunger of the MO with a pointed object or screwdriver until the valve switches and then turn clockwise through 90° until the stop is reached. The valve remains in switching position.
- [2] Turn the plunger anti-clockwise by 90° until the stop is reached and then remove the pointed object or screwdriver. The spring force pushes the plunger of the MO back. The valve returns to its normal position (not the case with double solenoid valve code J).

#### MO non-detenting – with coded cover cap

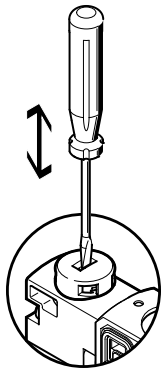

MO is actuated by pushing it with a pointed object or screwdriver and reset by spring force (detenting position prevented by coded cover cap).

#### MO detenting without tools – assembly

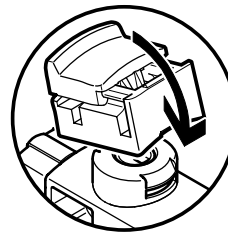

Clip MO with detent onto the pilot valve. The cap for the MO can then be operated (detenting) without tools.

#### MO detenting without tools – actuation

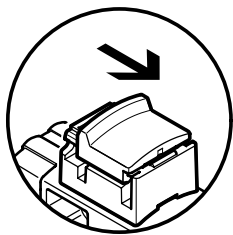

When sliding the cap for the MO with detent in the direction of the arrow:

- Cap locks into the stop position.
- Pilot valve switches and actuates the main valve.

#### MO detenting without tools – actuation

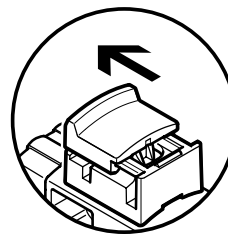

When sliding the cap for the MO with detent in the direction of the arrow:

- Cap locks into the stop position.
- The spring force pushes the plunger of the MO back.
- Pilot valve returns to its initial position as does the single solenoid main valve (not the case with double solenoid valve code J).

## Characteristics – Mounting

### Inscription system

Inscription label holder

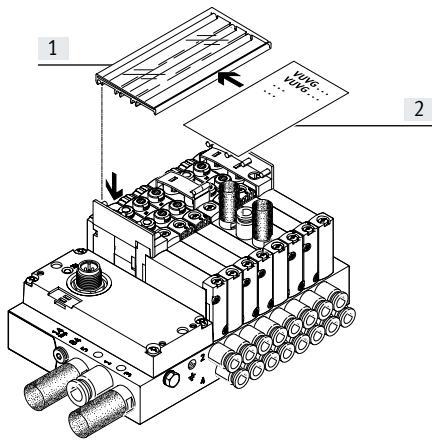

- [1] Inscription label holder  
ASCF-H-L1 (code TT)
- [2] Inscription area

Mount the inscription label holder to label the valves. Open the inscription label holder to insert the inscription label and actuate the manual override. The inscription label holders are available in different sizes depending on the number of valve positions.

**Note**

Do not engage the manual override before mounting the inscription label holder.

When mounted, the retaining bracket for the inscription label holder covers the manual override of the valves beneath it.

The manual override for the two valves under the retaining brackets of the inscription label holder can then only be actuated in a non-detenting manner.

### Identification holder

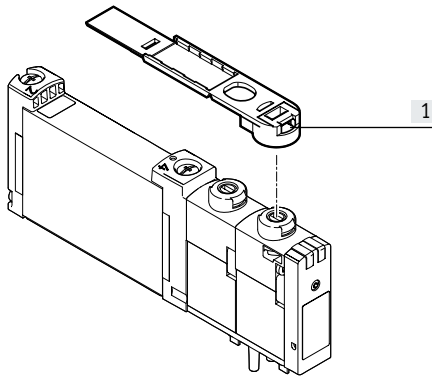

- [1] Identification holder ASLR-D-L1  
(code TV)

Use identification holders ASLR-D-L1 (code TV) to label individual valves. The identification holder is placed directly on the manual override.

**Note**

Do not engage the manual override before mounting the identification holder.

After the retaining brackets are fitted, the manual override can only be actuated in a non-detenting manner.

Overview of valve functions

Valve	Valve code	Description	Size		
			M5/M7	G1/8	G1/4
<b>3/2-way valve, pneumatic/mechanical spring</b>					
	M32C-R	Normally closed	■	-	-
	M32U-R	Normally open	■	-	-
<b>3/2-way valve, pneumatic spring</b>					
	M32C-A	Normally closed	-	■	-
	M32U-A	Normally open	-	■	-
<b>2x 3/2-way valve, pneumatic spring</b>					
	T32C-A	Normally closed	■	■	■
	T32U-A	Normally open	■	■	■
	T32H-A	1x normally open, 1x normally closed	■	■	■
<b>2x 3/2-way valve, mechanical spring</b>					
	T32C-M	Normally closed	■	■	■
	T32U-M	Normally open	■	■	■
	T32H-M	1x normally open, 1x normally closed	■	■	■

Valve terminal VTUG with multi-pin plug connection and fieldbus interface

Overview of valve functions

Valve	Valve code	Description	Size		
			M5/M7	G1/8	G1/4
<b>5/2-way valve, double solenoid</b>					
	B52	External pilot air supply	■	■	■
<b>5/2-way valve, single solenoid</b>					
	M52-A	Pneumatic spring	-	■	-
	M52-M	Mechanical spring	■	■	■
	M52-R	Pneumatic/mechanical spring	■	-	■
<b>5/3-way valve</b>					
	P53C	Mid-position closed	■	■	■
	P53U	Mid-position pressurised	■	■	■
	P53E	Mid-position exhausted	■	■	■

Peripherals overview example – Semi in-line valves

Valve terminal with multi-pin plug and I-Port interface

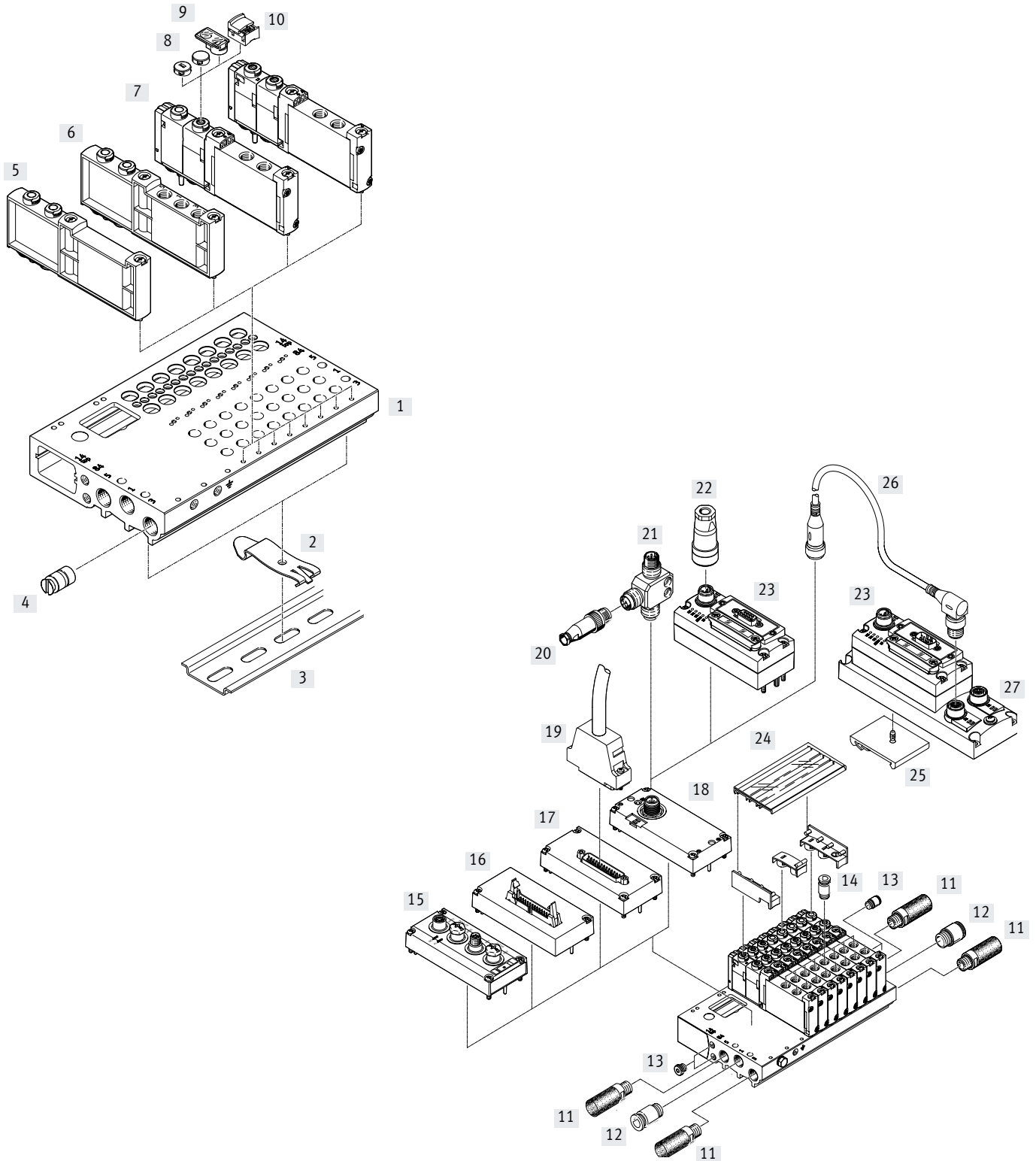

## Valve terminal VTUG with multi-pin plug connection and fieldbus interface

### Peripherals overview example – Semi in-line valves

Accessories		Type	Description	→ Page/Internet
[1]	Manifold rail	VABM-L1-...	For 4 to 10, 12, 16, 20 and 24 valve positions	156
[2]	H-rail mounting	VAME-T-M4	2 pieces for fitting the valve terminal on an H-rail	200
[3]	H-rail	NRH-35-2000	For mounting the valve terminal	200
[4]	Separator	VABD-...	For creating pressure zones	198
[5]	Cover plate	VABB-L1-...	For covering a vacant position	198
[6]	Supply plate	VABF-L1-...	For air supply at port 1 and ports 3 and 5	198
[7]	Solenoid valve	VUVG-...	Semi in-line valve	135, 139, 142
[8]	Cover cap	VMPA-HB...-B	For manual override	198
[9]	Identification holder	ASLR-D-L1	For inscription label and cover for the retaining screw/manual override	200
[10]	Cover	VAMC-...	For manual override	198
[11]	Silencer	U-...	For ports 3 and 5	198
[12]	Push-in fitting	QS-...	For air supply, port 1	197
[13]	Blanking plug	B-...	For internal/external pilot air	197
[14]	Push-in fitting	QS-...	For port 2 and 4	197
[15]	Electrical interface	VAEM-L1-S-...-AP	AP interface for CPX-AP-I	195
[16]	Electrical interface	VAEM-L1-S-M3-...	Ribbon cable	186
[17]	Electrical interface	VAEM-L1-S-M1-...	Sub-D	186
[18]	Electrical interface	VAEM-L1-S-...-PT	I-Port interface/IO-Link	189
[19]	Connecting cable	NEBV-...	Sub-D cable	186
[20]	Plug	SEA-M12-5GS-PG7	Straight, for T adapter FB-TA	189
[21]	T adapter	FB-TA-M12-5POL	For IO-Link and load voltage supply	189
[22]	Power supply socket	NTSD-.../FBSD-...	Power supply for CTEU bus node	196
[23]	CTEU	CTEU-...	Bus node	195
[24]	Inscription label holder	ASCF-H-L1	For identifying valves	200
[25]	H-rail mounting	CAFM-F1-H	For electrical connection block CAPC	191
[26]	Connecting cable	NEBU-...	–	nebu
[27]	Electrical connection block	CAPC-F1-E-M12	For connecting a second device with I-Port interface	191



Peripherals overview example – Sub-base valves

Valve terminal with multi-pin plug and I-Port interface

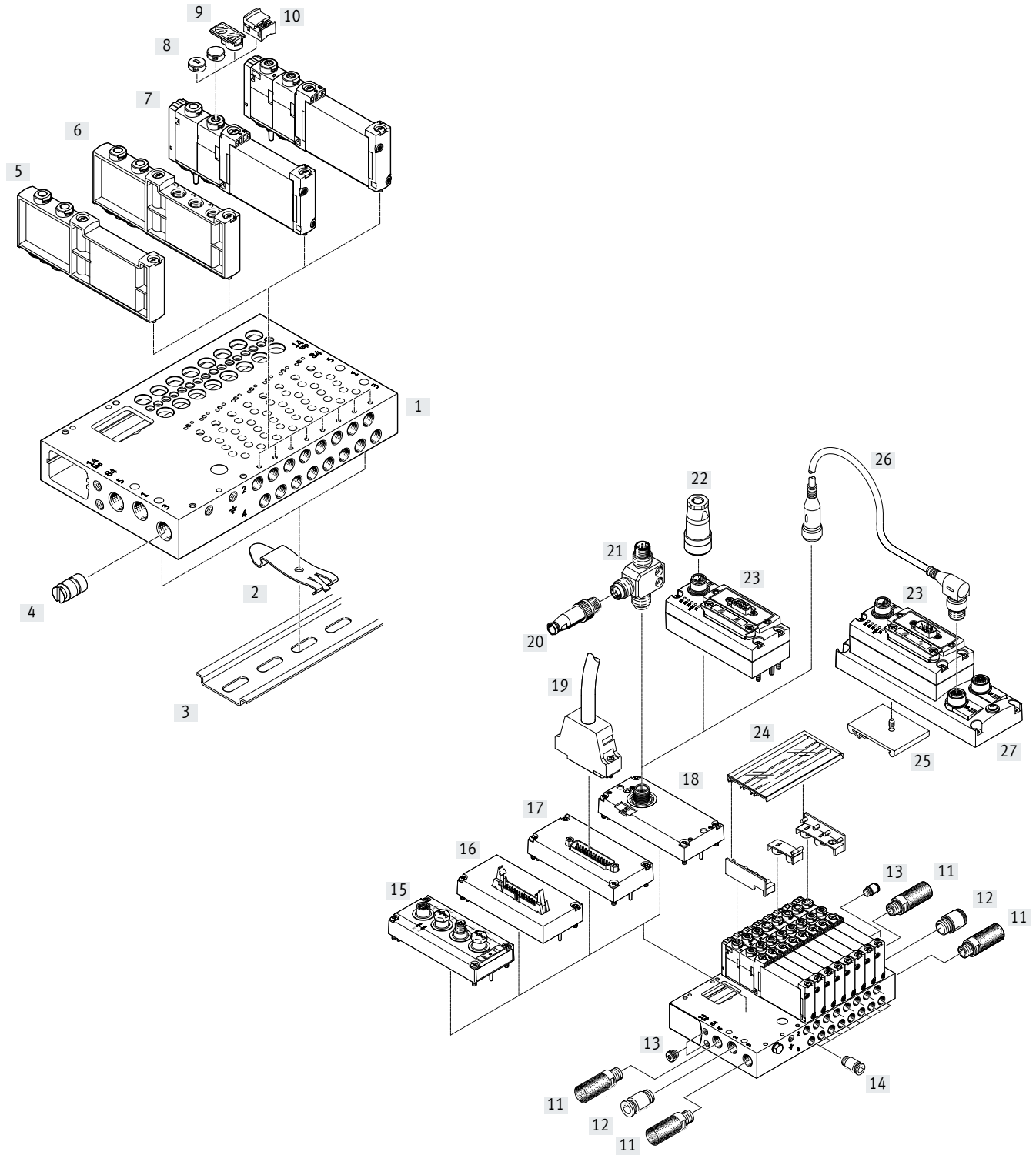

## Valve terminal VTUG with multi-pin plug connection and fieldbus interface

### Peripherals overview example – Sub-base valves

Accessories		Type	Description	→ Page/Internet
[1]	Manifold rail	VABM-L1-...	For 4 to 10, 12, 16, 20 and 24 valve positions	156
[2]	H-rail mounting	VAME-T-M4	2 pieces for fitting the valve terminal on an H-rail	200
[3]	H-rail	NRH-35-2000	For mounting the valve terminal	200
[4]	Separator	VABD-...	For creating pressure zones	198
[5]	Cover plate	VABB-L1-...	For covering a vacant position	198
[6]	Supply plate	VABF-L1-...	For air supply at port 1 and ports 3 and 5	198
[7]	Solenoid valve	VUVG- ...	Sub-base valve	145, 149, 153
[8]	Cover cap	VMPA-HB...-B	For manual override	198
[9]	Identification holder	ASLR-D-L1	For inscription label and cover for the retaining screw/manual override	200
[10]	Cover	VAMC...	For manual override	198
[11]	Silencer	U...	For ports 3 and 5	198
[12]	Push-in fitting	QS...	For air supply, port 1	197
[13]	Blanking plug	B-...	For internal/external pilot air	197
[14]	Push-in fitting	QS...	For port 2 and 4	197
[15]	Electrical interface	VAEM-L1-S-...-AP	AP interface for CPX-AP-I	195
[16]	Electrical interface	VAEM-L1-S-M3-...	Ribbon cable	186
[17]	Electrical interface	VAEM-L1-S-M1-...	Sub-D	186
[18]	Electrical interface	VAEM-L1-S-...-PT	I-Port interface/IO-Link	189
[19]	Connecting cable	NEBV-...	Sub-D cable	186
[20]	Plug	SEA-M12-5GS-PG7	Straight, for T adapter FB-TA	189
[21]	T adapter	FB-TA-M12-5POL	For IO-Link and load voltage supply	189
[22]	Power supply socket	FBSD-.../NTSD-...	Power supply for CTEU bus node	196
[23]	CTEU	CTEU-...	Bus node	195
[24]	Inscription label holder	ASCF-H-L1	For identifying valves	200
[25]	H-rail mounting	CAFM-F1-H	For electrical connection block CAPC	191
[26]	Connecting cable	NEBU-...	–	nebu
[27]	Electrical connection block	CAPC-F1-E-M12	For connecting a second device with I-Port interface	191

Peripherals overview example – Sub-base valves

I-Port interface with interlock

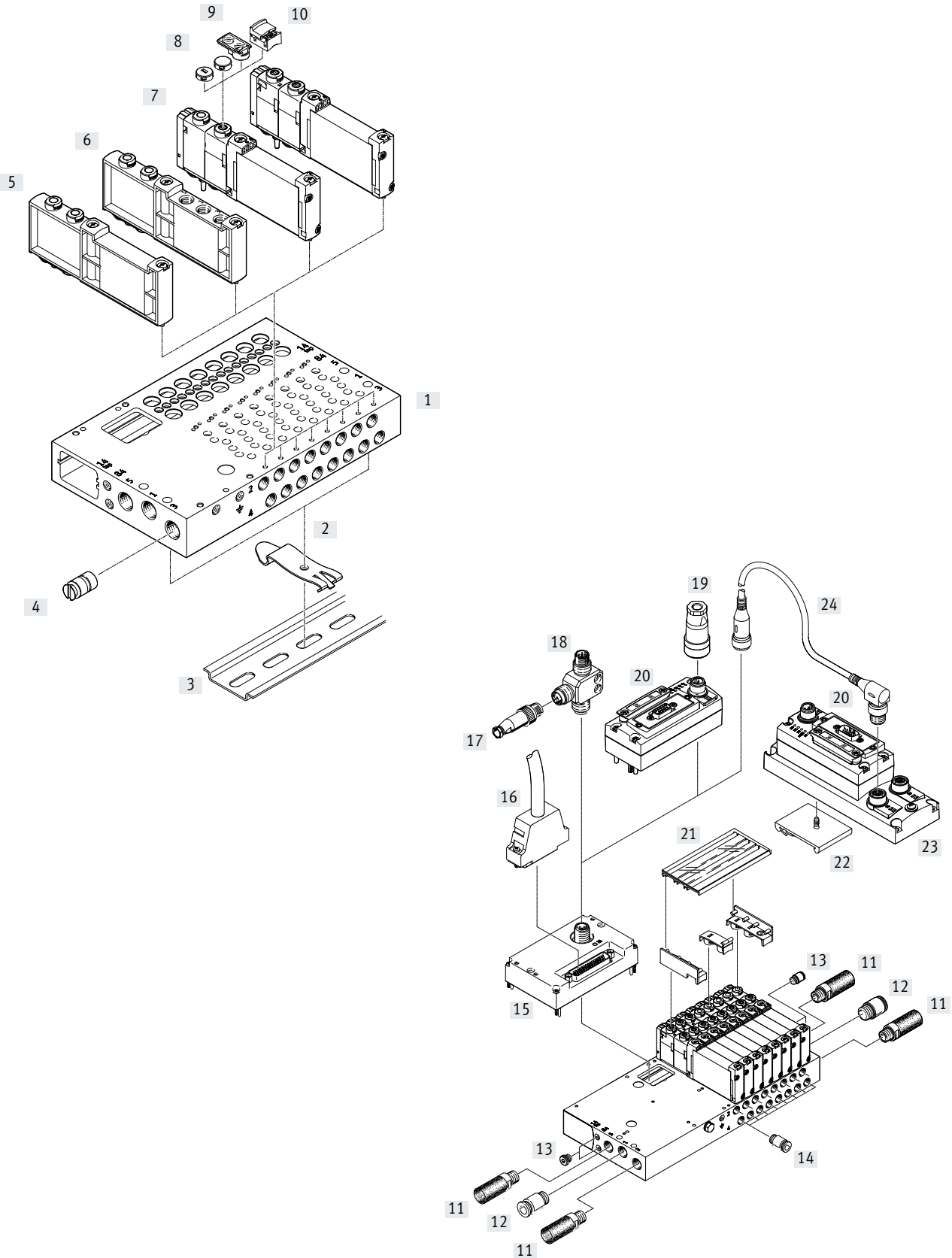

## Valve terminal VTUG with multi-pin plug connection and fieldbus interface

### Peripherals overview example – Sub-base valves

Accessories		Type	Description	→ Page/Internet
[1]	Manifold rail	VABM-L1-...	For 4 to 10, 12, 16, 20 and 24 valve positions	156
[2]	H-rail mounting	VAME-T-M4	2 pieces for fitting the valve terminal on an H-rail	200
[3]	H-rail	NRH-35-2000	For mounting the valve terminal	200
[4]	Separator	VABD-...	For creating pressure zones	198
[5]	Cover plate	VABB-L1-...	For covering a vacant position	198
[6]	Supply plate	VABF-L1-...	For air supply at port 1 and ports 3 and 5	198
[7]	Solenoid valve	VUVG-...	–	145, 149, 153
[8]	Cover cap	VMPPA-HB...-B	For manual override	198
[9]	Identification holder	ASLR-D-L1	For inscription label and cover for the retaining screw/manual override	200
[10]	Cover	VAMC-...	For manual override	198
[11]	Silencer	U-...	For ports 3 and 5	198
[12]	Push-in fitting	QS-...	For air supply, port 1	197
[13]	Blanking plug	B-...	For internal/external pilot air	197
[14]	Push-in fitting	QS-...	For port 2 and 4	197
[15]	Electrical interface	VAEM-L1-S-24-...	I-Port interface with interlock	192
[16]	Connecting cable	NEBV-...	Sub-D cable	186
[17]	Plug	SEA-M12-5GS-PG7	Straight, for T adapter FB-TA	189
[18]	T adapter	FB-TA-M12-5POL	For IO-Link and load voltage supply	189
[19]	Power supply socket	NTSD-.../FBSD-...	Power supply for CTEU bus node	196
[20]	CTEU	CTEU-...	Bus node	195
[21]	Inscription label holder	ASCF-H-L1	For identifying valves	200
[22]	H-rail mounting	CAF-M-F1-H	For electrical connection block CAPC	191
[23]	Electrical connection block	CAPC-F1-E-M12	For connecting a second device with I-Port interface	191
[24]	Connecting cable	NEBU-...	–	nebu

Peripherals overview example – Sub-base valves

**Valve terminal with multi-pin plug/fieldbus connection and individually electrically actuated valves**

In applications with specific emergency stop requirements, it may be necessary to switch one or more valves separately from the valve terminal controller.

Valves VUVG (→ page 11) with an individual electrical connection are mounted on the valve terminal for this purpose.

Valves with individual electrical connection require a special seal when mounted within a valve terminal.

They are therefore ordered/fitted as follows:

- together with the valve terminal using the valve terminal configurator
- individually/subsequently as a substitute for a cover plate in a vacant position

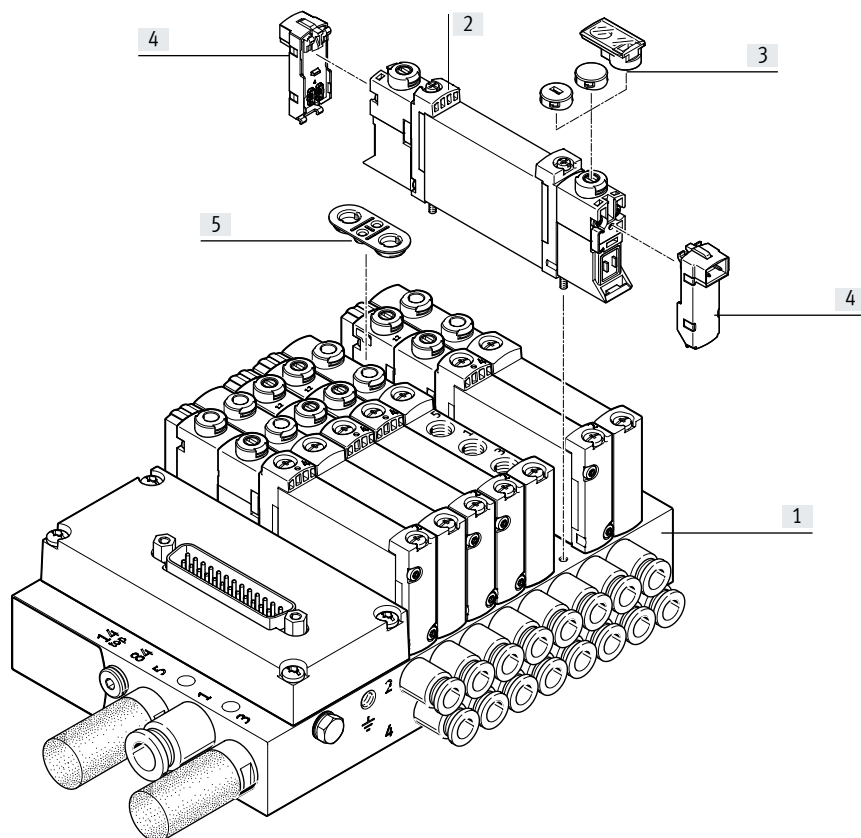

Accessories		Type	Description	→ Page/Internet
[1]	Manifold rail	VABM-L1-10	For 2 to 10, 12 and 16 valve positions	156
[2]	Solenoid valve	VUVG	Sub-base valve	77
[3]	Cover cap	VMPA	For manual override	198
[4]	E-box	VAVE	For individual connection	102
[5]	Seal	–	Included in the scope of delivery of the cover plate for a vacant position	198

Valve terminal VTUG with multi-pin plug connection and fieldbus interface

Type codes

001	Series	
<b>VUVG</b>	Solenoid valve	

002	Directional control valve type	
<b>S</b>	Semi-inline valve	
<b>B</b>	Sub-base valve	

003	Size	
<b>10</b>	Size 10	
<b>14</b>	Size 14	
<b>18</b>	Size 18	

004	Additional function	
<b>Z</b>	External pressure supply	
	None	

005	Valve function	
<b>M32U</b>	3/2-way valve, normally open	
<b>M32C</b>	3/2-way valve, normally closed	
<b>T32U</b>	2x3/2-way valve, normally open	
<b>T32C</b>	2x3/2-way valve, normally closed	
<b>T32H</b>	2x3/2-way valve, 1x normally closed, 1x normally open	
<b>M52</b>	5/2-way valve, single solenoid/monostable	
<b>B52</b>	5/2-way valve, double solenoid/bistable	
<b>P53U</b>	5/3-way valve, mid-position pressurised	
<b>P53E</b>	5/3-way valve, mid-position exhausted	
<b>P53C</b>	5/3-way valve, mid-position closed	

006	Reset method for monostable/single solenoid valves	
	None	
<b>A</b>	Pneumatic spring	
<b>M</b>	Mechanical spring	
<b>R</b>	Mixed, pneumatic/mechanical spring	

007	Pilot air	
<b>Z</b>	External	

008	Manual override	
<b>H</b>	Non-detenting	
<b>T</b>	Non-detenting, detenting with accessories	
<b>Y</b>	Detenting	
<b>S</b>	Covered	

009	Pneumatic connection	
<b>F</b>	Flange/sub-base	
<b>M5</b>	M5	
<b>M7</b>	M7	
<b>G18</b>	G1/8	
<b>G14</b>	G1/4	
<b>Q3</b>	Push-in connector 3 mm	
<b>Q4</b>	Push-in connector 4 mm	
<b>Q4H</b>	Push-in connector 4 mm, with connecting thread M7	
<b>Q6</b>	Push-in connector 6 mm	
<b>Q6H</b>	Push-in connector 6 mm, with connecting thread M7	
<b>Q8</b>	Push-in connector 8 mm	
<b>Q10</b>	Push-in connector 10 mm	
<b>T18</b>	Push-in connector 1/8"	
<b>T532</b>	Push-in connector 5/32"	
<b>T316</b>	Push-in connector 3/16"	
<b>T316H</b>	Push-in connector for 3/16", M7	
<b>T14</b>	Push-in connector 1/4"	
<b>T14H</b>	Push-in connector for 1/4", M7	
<b>T38</b>	Push-in connector 3/8"	
<b>T516</b>	Push-in connector 5/16"	

010	Nominal operating voltage	
<b>1</b>	24 V DC	

011	Electrical connection	
<b>T1</b>	Pin	



012	Display	
<b>L</b>	LED	

013	Degree of protection, electrical system	
	Standard	
<b>S6</b>	IP40	

014	EU certification	
	None	
<b>EX2</b>	II 3GD	

Data sheet – Semi in-line valves M5/M7

Function  
 2x 3/2C, 2x 3/2U, 2x 3/2H  
 5/2-way, single solenoid  
 5/2-way, double solenoid  
 5/3C, 5/3U, 5/3E

-  - Size 10 mm
-  - Flow rate  
130 ... 330 l/min
-  - Voltage  
24 V DC

Circuit symbols → page 13



General technical data													
Valve function	T32-A			T32-M			M52-R	B52	M52-M	P53			
Normal position	C <sup>1)</sup>	U <sup>2)</sup>	H <sup>4)</sup>	C <sup>1)</sup>	U <sup>2)</sup>	H <sup>4)</sup>	–	–	–	C <sup>1)</sup>	U <sup>2)</sup>	E <sup>3)</sup>	
Stable position	Monostable							Bistable	Monostable				
Reset method: pneumatic spring	Yes			No			Yes <sup>5)</sup>	–	No	–			
Reset method: mechanical spring	No			Yes			Yes <sup>5)</sup>	–	Yes	Yes			
Vacuum operation at port 1	No			With external pilot air									
Design	Piston spool												
Sealing principle	Soft												
Actuation type	Electric												
Type of control	Piloted												
Pilot air supply	External												
Exhaust air function	Can be throttled												
Manual override	Choice of non-detenting, covered, non-detenting/detenting or detenting												
Type of mounting	On manifold rail												
Mounting position	Any												
Overlap	Positive overlap										Indeterminate lap		
Signal status display	LED												
Flow rate on manifold rail M5	[l/min]		150			130			230		210		
Flow rate on manifold rail M7	[l/min]		160			140			330		290		
Size	[mm]		10										
Port	1, 3, 5, 12/14, 82/84		On manifold rail										
	2, 4		M5 (VUVG-S10-...-M5) M7 (VUVG-S10-...-M7)										
Product weight	[g]		59				53		60		53		58
Certification	c UL us – Recognized (OL)												
	c CSA us (OL)												
	RCM												
CE marking (see declaration of conformity) <sup>6)</sup>	To EU EMC Directive												
Corrosion resistance class CRC <sup>7)</sup>	2												

1) C=Normally closed/mid-position closed  
 2) U=Normally open/mid-position pressurised  
 3) E=mid-position exhausted  
 4) H=2x3/2-way valve in one housing with 1x normally closed and 1x normally open  
 5) Combined reset method  
 6) For information about the area of use, see the EC declaration of conformity at: [www.festo.com/sp](http://www.festo.com/sp) → Certificates.  
 If the devices are subject to usage restrictions in residential, commercial or light-industrial environments, further measures for the reduction of the emitted interference may be necessary.  
 7) Corrosion resistance class CRC 2 to Festo standard FN 940070  
 Moderate corrosion stress. Indoor applications in which condensation can occur. External visible parts with primarily decorative surface requirements which are in direct contact with a normal industrial environment.

## Valve terminal VTUG with multi-pin plug connection and fieldbus interface

### Data sheet – Semi in-line valves M5/M7

Operating and environmental conditions			T32-A <sup>1)</sup>	T32-M <sup>2)</sup>	M52-R <sup>3)</sup>	B52	M52-M <sup>2)</sup>	P53
Valve function			Compressed air to ISO 8573-1:2010 [7:4:4]					
Operating pressure	Internal pilot air supply	[bar]	1.5 ... 8	2 ... 8	2.5 ... 8	1.5 ... 8	3 ... 8	3 ... 8
	External pilot air supply	[bar]	1.5 ... 10	-0.9 ... 10			-0.9 ... 8	-0.9 ... 10
Pilot pressure <sup>4)</sup>		[bar]	1.5 ... 8	2 ... 8	2.5 ... 8	1.5 ... 8	3 ... 8	3 ... 8
Ambient temperature		[°C]	-5 ... +60					
Temperature of medium		[°C]	-5 ... +60					

- 1) Pneumatic spring  
 2) Mechanical spring  
 3) Mixed, pneumatic/mechanical spring  
 4) Minimum pilot pressure 50% of the operating pressure

Electrical data		
Electrical connection		Via sub-base
Operating voltage	[V DC]	24 ±10%
Power	[W]	1/0.4 (after 25 ms)
Duty cycle	[%]	100
Max. switching frequency	[Hz]	3
Degree of protection to EN 60529 <sup>1)</sup>	Individual valve	IP65, IP67
	Valve terminal VTUG	IP40, IP67/IP65, IP69K
	Valve terminal VTUG-VI-EX2	IP20, IP65

- 1) Depending on the configuration selected

Safety data		
Max. positive test pulse with 0 signal	[µs]	1600
Max. negative test pulse with 1 signal	[µs]	3000
Shock resistance	Shock test with severity level 2 to FN 942017-5 and EN 60068-2-27	
Vibration resistance	Transport application test with severity level 2 to FN 942017-4 and EN 60068-2-6	

Information on materials	
Housing	Wrought aluminium alloy
Seals	HNBR, NBR
Note on materials	RoHS-compliant

Valve switching times			T32-A <sup>1)</sup>	T32-M <sup>2)</sup>	M52-R <sup>3)</sup>	B52	M52-M <sup>2)</sup>	P53
Switching time on	[ms]	8	10	9	–	12	12	
Switching time off	[ms]	20	20	21	–	30	38	
Switching time changeover	[ms]	–	–	–	9	–	16	

- 1) Pneumatic spring  
 2) Mechanical spring  
 3) Mixed, pneumatic/mechanical spring



Data sheet – Semi in-line valves M5/M7

Dimensions

Download CAD data → [www.festo.com](http://www.festo.com)

Semi in-line valves M5/M7

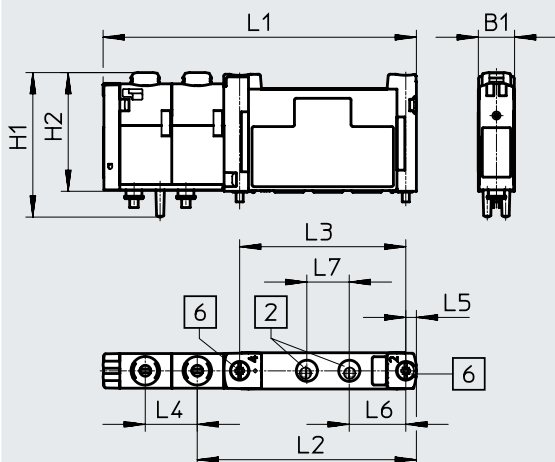

- [2] Ports 2 and 4: M7/M5
- [6] Retaining screw

Type	B1	H1	H2	L1	L2	L3	L4	L5	L6	L7
VUVG-S10-...-M5-1T1L	10.3	40.7	33.6	88.6	62	47	14.7	3	16	12
VUVG-S10-...-M7-1T1L										

Ordering data

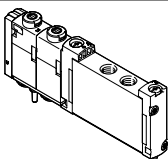
Description	Part no.	Type
<b>Semi in-line valve M5</b>		
<b>2x 3/2-way valve</b>		
 External pilot air supply	Normally closed, reset method: pneumatic spring	573386 VUVG-S10-T32C-AZT-M5-1T1L
	Normally open, reset method: pneumatic spring	573387 VUVG-S10-T32U-AZT-M5-1T1L
	1x normally open, 1x normally closed, reset method: pneumatic spring	573388 VUVG-S10-T32H-AZT-M5-1T1L
	Normally closed, reset method: mechanical spring	573389 VUVG-S10-T32C-MZT-M5-1T1L
	Normally open, reset method: mechanical spring	573390 VUVG-S10-T32U-MZT-M5-1T1L
	1x normally open, 1x normally closed, reset method: mechanical spring	573391 VUVG-S10-T32H-MZT-M5-1T1L
<b>5/2-way valve, single solenoid</b>		
External pilot air supply	Reset method: mechanical spring	573393 VUVG-S10-M52-MZT-M5-1T1L
	Reset method: pneumatic/mechanical spring	573392 VUVG-S10-M52-RZT-M5-1T1L
<b>5/2-way valve, double solenoid</b>		
External pilot air supply		573394 VUVG-S10-B52-ZT-M5-1T1L
<b>5/3-way valve</b>		
External pilot air supply	Mid-position closed, reset method: mechanical spring	573395 VUVG-S10-P53C-ZT-M5-1T1L
	Mid-position pressurised, reset method: mechanical spring	573397 VUVG-S10-P53U-ZT-M5-1T1L
	Mid-position exhausted, reset method: mechanical spring	573396 VUVG-S10-P53E-ZT-M5-1T1L

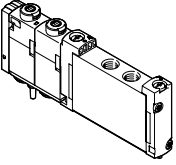

Valve terminal VTUG with multi-pin plug connection and fieldbus interface

Ordering data

Ordering data	Description	Part no.	Type	
<b>Semi in-line valve M7</b>				
	<b>2x 3/2-way valve</b>			
	External pilot air supply	Normally closed, reset method: pneumatic spring	573398	VUVG-S10-T32C-AZT-M7-1T1L
		Normally open, reset method: pneumatic spring	573399	VUVG-S10-T32U-AZT-M7-1T1L
		1x normally open, 1x normally closed, reset method: pneumatic spring	573400	VUVG-S10-T32H-AZT-M7-1T1L
		Normally closed, reset method: mechanical spring	573401	VUVG-S10-T32C-MZT-M7-1T1L
		Normally open, reset method: mechanical spring	573402	VUVG-S10-T32U-MZT-M7-1T1L
		1x normally open, 1x normally closed, reset method: mechanical spring	573403	VUVG-S10-T32H-MZT-M7-1T1L
	<b>5/2-way valve, single solenoid</b>			
	External pilot air supply	Reset method: mechanical spring	573405	VUVG-S10-M52-MZT-M7-1T1L
		Reset method: pneumatic/mechanical spring	573404	VUVG-S10-M52-RZT-M7-1T1L
	<b>5/2-way valve, double solenoid</b>			
	External pilot air supply		573406	VUVG-S10-B52-ZT-M7-1T1L
<b>5/3-way valve</b>				
External pilot air supply	Mid-position closed, reset method: mechanical spring	573407	VUVG-S10-P53C-ZT-M7-1T1L	
	Mid-position pressurised, reset method: mechanical spring	573409	VUVG-S10-P53U-ZT-M7-1T1L	
	Mid-position exhausted, reset method: mechanical spring	573408	VUVG-S10-P53E-ZT-M7-1T1L	

Data sheet – Semi in-line valves G1/8

Function  
 2x 3/2C, 2x 3/2U, 2x 3/2H  
 5/2-way, single solenoid  
 5/2-way, double solenoid  
 5/3C, 5/3U, 5/3E

-  - Size 14 mm
-  - Flow rate  
520 ... 630 l/min
-  - Voltage  
24 V DC

Circuit symbols → page 13



General technical data												
Valve function	T32-A			T32-M			M52-A	B52	M52-M	P53		
Normal position	C <sup>1)</sup>	U <sup>2)</sup>	H <sup>4)</sup>	C <sup>1)</sup>	U <sup>2)</sup>	H <sup>4)</sup>	-	-	-	C <sup>1)</sup>	U <sup>2)</sup>	E <sup>3)</sup>
Stable position	Monostable							Bistable	Monostable			
Reset method: pneumatic spring	Yes			No			Yes	-	No	-		
Reset method: mechanical spring	No			Yes			No	-	Yes	Yes		
Vacuum operation at port 1	No			With external pilot air								
Design	Piston spool											
Sealing principle	Soft											
Actuation type	Electric											
Type of control	Piloted											
Pilot air supply	External											
Exhaust air function	Can be throttled											
Manual override	Choice of non-detenting, covered, non-detenting/detenting or detenting											
Type of mounting	On manifold rail											
Mounting position	Any											
Overlap	Positive overlap											
Signal status display	LED											
Flow rate on manifold rail G1/8	[l/min]	610	520	620	630	620	590					
Size	[mm]	14										
Port	1, 3, 5, 12/14, 82/84 2, 4	On manifold rail G1/8										
Product weight	[g]	102	100	91	98	89	95					
Certification	c UL us – Recognized (OL)											
	c CSA us (OL)											
	RCM											
CE marking (see declaration of conformity) <sup>5)</sup>	To EU EMC Directive											
Corrosion resistance class CRC <sup>6)</sup>	2											

- 1) C=Normally closed/mid-position closed
- 2) U=Normally open/mid-position pressurised
- 3) E=mid-position exhausted
- 4) H=2x3/2-way valve in one housing with 1x normally closed and 1x normally open
- 5) For information about the area of use, see the EC declaration of conformity at: [www.festo.com/sp](http://www.festo.com/sp) → Certificates.  
If the devices are subject to usage restrictions in residential, commercial or light-industrial environments, further measures for the reduction of the emitted interference may be necessary.
- 6) Corrosion resistance class CRC 2 to Festo standard FN 940070  
Moderate corrosion stress. Indoor applications in which condensation can occur. External visible parts with primarily decorative surface requirements which are in direct contact with a normal industrial environment.

## Valve terminal VTUG with multi-pin plug connection and fieldbus interface

### Data sheet – Semi in-line valves G1/8

Operating and environmental conditions			T32-A <sup>1)</sup>	T32-M <sup>2)</sup>	M52-A <sup>1)</sup>	B52	M 52-M <sup>2)</sup>	P53
Valve function			Compressed air to ISO 8573-1:2010 [7:4:4]					
Operating pressure	Internal pilot air supply	[bar]	1.5 ... 8	2 ... 8	2.5 ... 8	1.5 ... 8	3 ... 8	3 ... 8
	External pilot air supply	[bar]	1.5 ... 10	-0.9 ... 10			-0.9 ... 8	-0.9 ... 10
Pilot pressure <sup>3)</sup>		[bar]	1.5 ... 8	2 ... 8	2.5 ... 8	1.5 ... 8	3 ... 8	3 ... 8
Ambient temperature		[°C]	-5 ... +60					
Temperature of medium		[°C]	-5 ... +60					

- 1) Pneumatic spring  
 2) Mechanical spring  
 3) Minimum pilot pressure 50% of the operating pressure

Electrical data		
Electrical connection		Via sub-base
Operating voltage	[V DC]	24 ±10%
Power	[W]	1/0.4 (after 25 ms)
Duty cycle	[%]	100
Max. switching frequency	[Hz]	3
Degree of protection to EN 60529 <sup>1)</sup>	Individual valve	IP65, IP67
	Valve terminal VTUG	IP40, IP67/IP65, IP69K
	Valve terminal VTUG-VI-EX2	IP20, IP65

- 1) Depending on the configuration selected

Safety data		
Max. positive test pulse with 0 signal	[µs]	1600
Max. negative test pulse with 1 signal	[µs]	3000
Shock resistance	Shock test with severity level 2 to FN 942017-5 and EN 60068-2-27	
Vibration resistance	Transport application test with severity level 2 to FN 942017-4 and EN 60068-2-6	

Information on materials	
Housing	Wrought aluminium alloy
Seals	HNBR, NBR
Note on materials	RoHS-compliant

Valve switching times		T32-A <sup>1)</sup>	T32-M <sup>2)</sup>	M52-A <sup>1)</sup>	B52	M 52-M <sup>2)</sup>	P53
Switching time on	[ms]	10	13	13	–	10	15
Switching time off	[ms]	29	21	26	–	38	42
Switching time changeover	[ms]	–	–	–	9	–	25

- 1) Pneumatic spring  
 2) Mechanical spring

Data sheet – Semi in-line valves G1/8

Dimensions

Download CAD data → [www.festo.com](http://www.festo.com)

Semi in-line valves G1/8

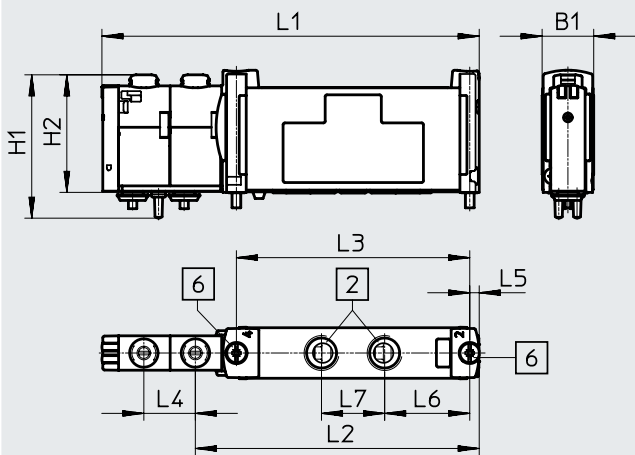

- [2] Ports 2 and 4: G1/8
- [6] Retaining screw

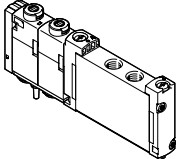

Type	B1	H1	H2	L1	L2	L3	L4	L5	L6	L7
VUVG-S14-...-G18-1T1L	14.7	40.9	33.5	107.6	81	66.5	14.7	2.8	24.3	18

Ordering data

Description	Part no.	Type
<b>Semi in-line valve G1/8</b>		
 <b>2x 3/2-way valve</b> External pilot air supply	Normally closed, reset method: pneumatic spring	573464 VUVG-S14-T32C-AZT-G18-1T1L
	Normally open, reset method: pneumatic spring	573465 VUVG-S14-T32U-AZT-G18-1T1L
	1x normally open, 1x normally closed, reset method: pneumatic spring	573466 VUVG-S14-T32H-AZT-G18-1T1L
	Normally closed, reset method: mechanical spring	573467 VUVG-S14-T32C-MZT-G18-1T1L
	Normally open, reset method: mechanical spring	573468 VUVG-S14-T32U-MZT-G18-1T1L
	1x normally open, 1x normally closed, reset method: mechanical spring	573469 VUVG-S14-T32H-MZT-G18-1T1L
<b>5/2-way valve, single solenoid</b>		
External pilot air supply	Reset method: pneumatic spring	573470 VUVG-S14-M52-AZT-G18-1T1L
	Reset method: mechanical spring	573471 VUVG-S14-M52-MZT-G18-1T1L
<b>5/2-way valve, double solenoid</b>		
External pilot air supply		573472 VUVG-S14-B52-ZT-G18-1T1L
<b>5/3-way valve</b>		
External pilot air supply	Mid-position closed, reset method: mechanical spring	573473 VUVG-S14-P53C-ZT-G18-1T1L
	Mid-position pressurised, reset method: mechanical spring	573475 VUVG-S14-P53U-ZT-G18-1T1L
	Mid-position exhausted, reset method: mechanical spring	573474 VUVG-S14-P53E-ZT-G18-1T1L

Valve terminal VTUG with multi-pin plug connection and fieldbus interface

Data sheet – Semi in-line valves G1/4

- Function  
2x 3/2C, 2x 3/2U, 2x 3/2H  
5/2-way, single solenoid  
5/2-way, double solenoid  
5/3C, 5/3U, 5/3E
  -  - Size 18 mm
  -  - Flow rate  
900 ... 1200 l/min
  -  - Voltage  
24 V DC
- Circuit symbols → page 13

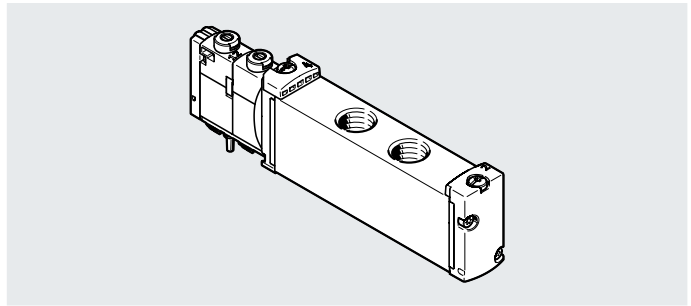

General technical data												
Valve function	T32-A			T32-M			M52-R	B52	M52-M	P53		
Normal position	C <sup>1)</sup>	U <sup>2)</sup>	H <sup>4)</sup>	C <sup>1)</sup>	U <sup>2)</sup>	H <sup>4)</sup>	–	–	–	C <sup>1)</sup>	U <sup>2)</sup>	E <sup>3)</sup>
Stable position	Monostable							Bistable	Monostable			
Reset method: pneumatic spring	Yes			No			Yes <sup>5)</sup>	–	No	–		
Reset method: mechanical spring	No			Yes			Yes <sup>5)</sup>	–	Yes	Yes		
Vacuum operation at port 1	No			With external pilot air								
Design	Piston spool											
Sealing principle	Soft											
Actuation type	Electric											
Type of control	Piloted											
Pilot air supply	External											
Exhaust air function	Can be throttled											
Manual override	Choice of non-detenting, covered, non-detenting/detenting or detenting											
Type of mounting	On manifold rail											
Mounting position	Any											
Overlap	Positive overlap						Indeterminate overlap	Over-lap	Indeterminate overlap	Positive overlap	Indeterminate overlap	
Signal status display	LED											
Flow rate on manifold rail G1/8	[l/min]	900	900	1150	1200	1150	1000					
Size	[mm]	18										
Port	1, 3, 5, 12/14, 82/84 2, 4	On manifold rail G1/4										
Product weight	[g]	145	147	138	145	138	140					
Certification	c UL us – Recognized (OL)											
	c CSA us (OL)											
	RCM											
CE marking (see declaration of conformity) <sup>6)</sup>	To EU EMC Directive											
Corrosion resistance class CRC <sup>7)</sup>	2											

1) C=Normally closed/mid-position closed  
 2) U=Normally open/mid-position pressurised  
 3) E=mid-position exhausted  
 4) H=2x3/2-way valve in one housing with 1x normally closed and 1x normally open  
 5) Combined reset method  
 6) For information about the area of use, see the EC declaration of conformity at: [www.festo.com/sp](http://www.festo.com/sp) → Certificates.  
 If the devices are subject to usage restrictions in residential, commercial or light-industrial environments, further measures for the reduction of the emitted interference may be necessary.  
 7) Corrosion resistance class CRC 2 to Festo standard FN 940070  
 Moderate corrosion stress. Indoor applications in which condensation can occur. External visible parts with primarily decorative surface requirements which are in direct contact with a normal industrial environment.

Data sheet – Semi in-line valves G1/4

Operating and environmental conditions								
Valve function			T32-A <sup>1)</sup>	T32-M <sup>2)</sup>	M52-R <sup>3)</sup>	B52	M52-M <sup>2)</sup>	P53
Operating medium	Compressed air to ISO 8573-1:2010 [7:4:4]							
Pilot medium	Compressed air to ISO 8573-1:2010 [7:4:4]							
Note on the operating/pilot medium	Lubricated operation possible (in which case lubricated operation will always be required)							
Operating pressure	Internal pilot air supply	[bar]	1.5 ... 8	2 ... 8	2.5 ... 8	1.5 ... 8	3 ... 8	3 ... 8
	External pilot air supply	[bar]	1.5 ... 10	-0.9 ... 10			-0.9 ... 8	-0.9 ... 10
Pilot pressure <sup>4)</sup>		[bar]	1.5 ... 8	2 ... 8	2.5 ... 8	1.5 ... 8	3 ... 8	3 ... 8
Ambient temperature		[°C]	-5 ... +60					
Temperature of medium		[°C]	-5 ... +60					

- 1) Pneumatic spring
- 2) Mechanical spring
- 3) Mixed, pneumatic/mechanical spring
- 4) Minimum pilot pressure 50% of the operating pressure

Electrical data		
Electrical connection	Via sub-base	
Operating voltage	[V DC]	24 ±10%
Power	[W]	1
Duty cycle	[%]	100
Max. switching frequency	[Hz]	3
Degree of protection to EN 60529 <sup>1)</sup>	Individual valve	IP65, IP67
	Valve terminal VTUG	IP40, IP67/IP65, IP69K
	Valve terminal VTUG-VI-EX2	IP20, IP65

- 1) Depending on the configuration selected

Safety data		
Max. positive test pulse with 0 signal	[µs]	1600
Max. negative test pulse with 1 signal	[µs]	3000
Shock resistance	Shock test with severity level 2 to FN 942017-5 and EN 60068-2-27	
Vibration resistance	Transport application test with severity level 2 to FN 942017-4 and EN 60068-2-6	

Information on materials	
Housing	Wrought aluminium alloy
Seals	HNBR, NBR
Note on materials	RoHS-compliant

Valve switching times								
Valve function			T32-A <sup>1)</sup>	T32-M <sup>2)</sup>	M52-R <sup>3)</sup>	B52	M52-M <sup>2)</sup>	P53
Switching time on	[ms]		15	25	20	–	13	20
Switching time off	[ms]		35	33	35	–	50	57
Switching time changeover	[ms]		–	–	–	15	–	31

- 1) Pneumatic spring
- 2) Mechanical spring
- 3) Mixed, pneumatic/mechanical spring

Valve terminal VTUG with multi-pin plug connection and fieldbus interface

Data sheet – Semi in-line valves G1/4

Dimensions

Download CAD data → [www.festo.com](http://www.festo.com)

Semi in-line valve G1/4

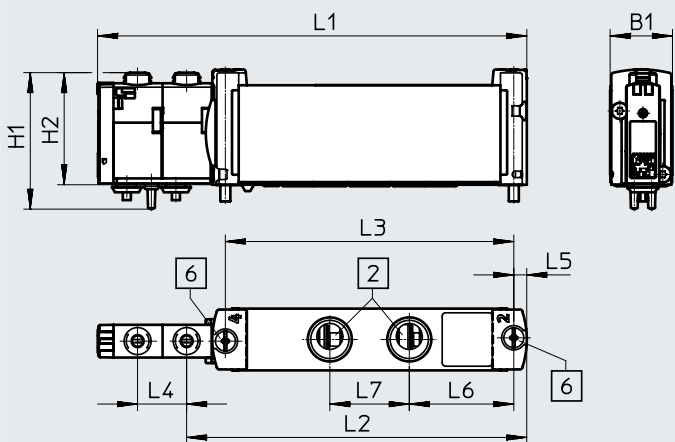

- [2] Ports 2 and 4: G1/4
- [6] Retaining screw

Type	B1	H1	H2	L1	L2	L3	L4	L5	L6	L7
VUVG-S18-...-G14-1T1L	18.7	40.9	33.6	128.6	101.9	86.4	14.7	3.9	31.3	23.8

Ordering data

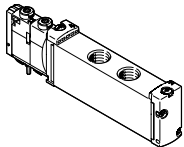
Description	Part no.	Type
<b>Semi in-line valve G1/4</b>		
<b>2x 3/2-way valve</b>		
 External pilot air supply	Normally closed	8004873 VUVG-S18-T32C-AZT-G14-1T1L
	Normally open, reset method: pneumatic spring	8004874 VUVG-S18-T32U-AZT-G14-1T1L
	1x normally open, 1x normally closed, reset method: pneumatic spring	8004875 VUVG-S18-T32H-AZT-G14-1T1L
	Normally closed, reset method: mechanical spring	8004876 VUVG-S18-T32C-MZT-G14-1T1L
	Normally open, reset method: mechanical spring	8004877 VUVG-S18-T32U-MZT-G14-1T1L
	1x normally open, 1x normally closed, reset method: mechanical spring	8004878 VUVG-S18-T32H-MZT-G14-1T1L
<b>5/2-way valve, single solenoid</b>		
External pilot air supply	Reset method: pneumatic/mechanical spring	8004879 VUVG-S18-M52-RZT-G14-1T1L
	Reset method: mechanical spring	8004880 VUVG-S18-M52-MZT-G14-1T1L
<b>5/2-way valve, double solenoid</b>		
External pilot air supply		8004881 VUVG-S18-B52-ZT-G14-1T1L
<b>5/3-way valve</b>		
External pilot air supply	Mid-position closed	8004882 VUVG-S18-P53C-ZT-G14-1T1L
	Mid-position pressurised	8004883 VUVG-S18-P53E-ZT-G14-1T1L
	Mid-position exhausted	8004884 VUVG-S18-P53U-ZT-G14-1T1L



Data sheet – Sub-base valves M5/M7

Function

3/2C, 3/2U

2x 3/2C, 2x 3/2U, 2x 3/2H

5/2-way, single solenoid

5/2-way, double solenoid

5/3C, 5/3U, 5/3E

-  - Size 10 mm

-  - Flow rate  
130 ... 300 l/min

-  - Voltage  
24 V DC



Circuit symbols → page 13

General technical data

Valve function	T32-A	T32-M	M32-R	M52-R	B52	M52-M	P53
Normal position	C <sup>1)</sup> U <sup>2)</sup> H <sup>4)</sup>	C <sup>1)</sup> U <sup>2)</sup> H <sup>4)</sup>	C <sup>1)</sup> U <sup>2)</sup>	-	-	-	C <sup>1)</sup> U <sup>2)</sup> E <sup>3)</sup>
Stable position	Monostable				Bistable	Monostable	
Reset method: pneumatic spring	Yes	No	No	Yes <sup>5)</sup>	-	No	-
Reset method: mechanical spring	No	Yes	Yes	Yes <sup>5)</sup>	-	Yes	Yes
Vacuum operation at port 1	No	With external pilot air					
Design	Piston spool						
Sealing principle	Soft						
Actuation type	Electric						
Type of control	Piloted						
Pilot air supply	External						
Exhaust air function	Can be throttled						
Manual override	Choice of non-detenting, covered, non-detenting/detenting or detenting						
Type of mounting	On manifold rail						
Mounting position	Any						
Overlap	Positive overlap						Indeterminate overlap
Signal status display	LED						
Standard nominal flow rate M5/M7	[l/min]	160	140	140	300	260	260
Flow rate on manifold rail M5, front	[l/min]	150	130	130	220	220	200
Flow rate on manifold rail M7, front	[l/min]	160	140	140	270	240	250
Flow rate on manifold rail M7, underneath	[l/min]	160	140	140	300	260	260
Size	[mm]	10					
Port	1, 3, 5, 12/14, 82/84	On manifold rail					
	2, 4	On manifold rail					
Product weight	[g]	59	53	60	53	58	
Certification	c UL us – Recognized (OL)						
	c CSA us (OL)						
	RCM						
CE marking (see declaration of conformity) <sup>6)</sup>	To EU EMC Directive						
Corrosion resistance class CRC <sup>7)</sup>	2						

1) C=Normally closed/mid-position closed

2) U=Normally open/mid-position pressurised

3) E=mid-position exhausted

4) H=2x3/2-way valve in one housing with 1x normally closed and 1x normally open

5) Combined reset method

6) For information about the area of use, see the EC declaration of conformity at: [www.festo.com/sp](http://www.festo.com/sp) → Certificates.

If the devices are subject to usage restrictions in residential, commercial or light-industrial environments, further measures for the reduction of the emitted interference may be necessary.

7) Corrosion resistance class CRC 2 to Festo standard FN 940070

Moderate corrosion stress. Indoor applications in which condensation can occur. External visible parts with primarily decorative surface requirements which are in direct contact with a normal industrial environment.

## Valve terminal VTUG with multi-pin plug connection and fieldbus interface

### Data sheet – Sub-base valves M5/M7

Operating and environmental conditions			T32-A <sup>1)</sup>	T32-M <sup>2)</sup>	M32-R <sup>3)</sup>	M52-R <sup>3)</sup>	B52	M52-M <sup>2)</sup>	P53
Valve function									
Operating medium			Compressed air to ISO 8573-1:2010 [7:4:4]						
Operating pressure	Internal pilot air supply	[bar]	1.5 ... 8	2.5 ... 8	2.5 ... 8	2.5 ... 8	1.5 ... 8	3 ... 8	3 ... 8
	External pilot air supply	[bar]	1.5 ... 10	-0.9 ... 10				-0.9 ... 8	-0.9 ... 10
Pilot pressure <sup>4)</sup>		[bar]	1.5 ... 8	2 ... 8	2.5 ... 8	2.5 ... 8	1.5 ... 8	3 ... 8	3 ... 8
Ambient temperature		[°C]	-5 ... +60						
Temperature of medium		[°C]	-5 ... +60						

- 1) Pneumatic spring
- 2) Mechanical spring
- 3) Mixed, pneumatic/mechanical spring
- 4) Minimum pilot pressure 50% of the operating pressure

Electrical data		
Electrical connection		Via sub-base
Operating voltage	[V DC]	24 ±10%
Power consumption per valve solenoid	[W]	1/0.4 (after 25 ms)
Duty cycle	[%]	100
Max. switching frequency	[Hz]	3
Degree of protection to EN 60529 <sup>1)</sup>	Individual valve	IP65, IP67
	Valve terminal VTUG	IP40, IP67/IP65, IP69K
	Valve terminal VTUG-VI-EX2	IP20, IP65

- 1) Depending on the configuration selected

Safety data		
Max. positive test pulse with 0 signal	[µs]	1600
Max. negative test pulse with 1 signal	[µs]	3000
Shock resistance		Shock test with severity level 2 to FN 942017-5 and EN 60068-2-27
Vibration resistance		Transport application test with severity level 2 to FN 942017-4 and EN 60068-2-6

ATEX		
Type		VTUG-VI-EX2
ATEX category for gas		II 3G
Type of ignition protection for gas		Ex ec IIC T4 Gc
ATEX category for dust		II 3D
Type of ignition protection for dust		Ex tc IIIC T135°C Dc
Explosion protection certification outside the EU		EPL Dc (IEC-EX) EPL Gc (IEC-EX)
Explosion-proof ambient temperature	[°C]	5°C ≤ Ta ≤ +50°C, -5°C ≤ Ta ≤ +60°C
CE marking (see declaration of conformity)		In accordance with the EU EMC Directive, the EU Explosion Protection Directive (ATEX) and the EU RoHS Directive
Certificate issuing authority		IBExU16ATEXB021 X
		IECEX IBE 17.0003 X

Information on materials		
Housing		Wrought aluminium alloy
Seals		HNBR, NBR
Note on materials		RoHS-compliant

Valve switching times			T32-A <sup>1)</sup>	T32-M <sup>2)</sup>	M32-R <sup>3)</sup>	M52-R <sup>3)</sup>	B52	M52-M <sup>2)</sup>	P53
Valve function									
Switching time on	[ms]		8	10	9	9	-	12	12
Switching time off	[ms]		20	20	17	21	-	30	38
Switching time changeover	[ms]		-	-	-	-	9	-	16

- 1) Pneumatic spring
- 2) Mechanical spring
- 3) Mixed, pneumatic/mechanical spring

Data sheet – Sub-base valves M5/M7

Dimensions

Download CAD data → [www.festo.com](http://www.festo.com)

Sub-base valve M5/M7

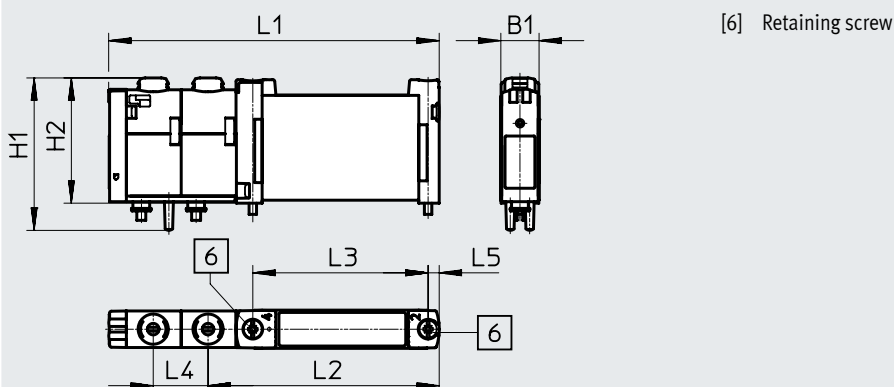

Type	B1	H1	H2	L1	L2	L3	L4	L5
VUVG-B10-...-F-1T1L	10.3	40.7	33	88.6	62	47	14.7	3
VUVG-B10-...-F-1T1L-EX2C								

Ordering data



Description	Part no.	Type
<b>Sub-base valve M5/M7</b>		
<b>3/2-way valve</b>		
External pilot air supply	Normally closed, reset method: mechanical spring	8028231 VUVG-B10Z-M32C-RZT-F-1T1L
	Normally open, reset method: mechanical spring	8028232 VUVG-B10Z-M32U-RZT-F-1T1L
<b>2x 3/2-way valve</b>		
External pilot air supply	Normally closed, reset method: pneumatic spring	573410 VUVG-B10-T32C-AZT-F-1T1L
	Normally open, reset method: pneumatic spring	573411 VUVG-B10-T32U-AZT-F-1T1L
	1x normally open, 1x normally closed, reset method: pneumatic spring	573412 VUVG-B10-T32H-AZT-F-1T1L
	Normally closed, reset method: mechanical spring	573413 VUVG-B10-T32C-MZT-F-1T1L
	Normally open, reset method: mechanical spring	573414 VUVG-B10-T32U-MZT-F-1T1L
	1x normally open, 1x normally closed, reset method: mechanical spring	573415 VUVG-B10-T32H-MZT-F-1T1L
<b>5/2-way valve, single solenoid</b>		
External pilot air supply	Reset method: mechanical spring	573417 VUVG-B10-M52-MZT-F-1T1L
	Reset method: pneumatic/mechanical spring	573416 VUVG-B10-M52-RZT-F-1T1L
<b>5/2-way valve, double solenoid</b>		
External pilot air supply		573418 VUVG-B10-B52-ZT-F-1T1L
<b>5/3-way valve</b>		
External pilot air supply	Mid-position closed, reset method: mechanical spring	573419 VUVG-B10-P53C-ZT-F-1T1L
	Mid-position pressurised, reset method: mechanical spring	573421 VUVG-B10-P53U-ZT-F-1T1L
	Mid-position exhausted, reset method: mechanical spring	573420 VUVG-B10-P53E-ZT-F-1T1L

Valve terminal VTUG with multi-pin plug connection and fieldbus interface

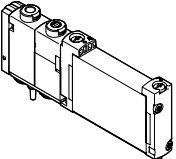
Data sheet – Sub-base valves M5/M7

Ordering data	Description	Part no.	Type	
<b>Sub-base valve M5/M7</b>				
	<b>3/2-way valve</b>			
	External pilot air supply	Normally closed, reset method: pneumatic/mechanical spring	8041900	VUVG-B10Z-M32C-RZT-F-1T1L-EX2C
		Normally open, reset method: pneumatic/mechanical spring	8041901	VUVG-B10Z-M32U-RZT-F-1T1L-EX2C
	<b>2x 3/2-way valve</b>			
	External pilot air supply	Normally closed, reset method: pneumatic spring	8041895	VUVG-B10-T32C-AZT-F-1T1L-EX2C
		Normally open, reset method: pneumatic spring	8041896	VUVG-B10-T32U-AZT-F-1T1L-EX2C
		1x normally open, 1x normally closed, reset method: pneumatic spring	8041897	VUVG-B10-T32H-AZT-F-1T1L-EX2C
		Normally closed, reset method: mechanical spring	8041891	VUVG-B10-T32C-MZT-F-1T1L-EX2C
		Normally open, reset method: mechanical spring	8041898	VUVG-B10-T32U-MZT-F-1T1L-EX2C
		1x normally open, 1x normally closed, reset method: mechanical spring	8041899	VUVG-B10-T32H-MZT-F-1T1L-EX2C
	<b>5/2-way valve, single solenoid</b>			
	External pilot air supply	Reset method: mechanical spring	8041892	VUVG-B10-M52-MZT-F-1T1L-EX2C
		Reset method: pneumatic/mechanical spring	8041889	VUVG-B10-M52-RZT-F-1T1L-EX2C
	<b>5/2-way valve, double solenoid</b>			
	External pilot air supply		8041888	VUVG-B10-B52-ZT-F-1T1L-EX2C
<b>5/3-way valve</b>				
External pilot air supply	Mid-position closed, reset method: mechanical spring	8041890	VUVG-B10-P53C-ZT-F-1T1L-EX2C	
	Mid-position pressurised, reset method: mechanical spring	8041893	VUVG-B10-P53U-ZT-F-1T1L-EX2C	
	Mid-position exhausted, reset method: mechanical spring	8041894	VUVG-B10-P53E-ZT-F-1T1L-EX2C	

Data sheet – Sub-base valves G1/8

- Function
  - 3/2C, 3/2U
  - 2x 3/2C, 2x 3/2U, 2x 3/2H
  - 5/2-way, single solenoid
  - 5/2-way, double solenoid
  - 5/3C, 5/3U, 5/3E
-  - Size 14 mm
  -  - Flow rate  
350 ... 560 l/min
  -  - Voltage  
24 V DC



Circuit symbols → page 13

General technical data															
Valve function	T32-A			T32-M			M32-A		M52-A	B52	M52-M	P53			
Normal position	C <sup>1)</sup>	U <sup>2)</sup>	H <sup>4)</sup>	C <sup>1)</sup>	U <sup>2)</sup>	H <sup>4)</sup>	C <sup>1)</sup>	U <sup>2)</sup>	-	-	-	C <sup>1)</sup>	U <sup>2)</sup>	E <sup>3)</sup>	
Stable position	Monostable									Bistable		Monostable			
Reset method: pneumatic spring	Yes			No			Yes		Yes	-	No	-			
Reset method: mechanical spring	No			Yes			No		No	-	Yes	Yes			
Vacuum operation at port 1	No			With external pilot air											
Design	Piston spool														
Sealing principle	Soft														
Actuation type	Electric														
Type of control	Piloted														
Pilot air supply	External														
Exhaust air function	Can be throttled														
Manual override	Choice of non-detenting, covered, non-detenting/detenting or detenting														
Type of mounting	On manifold rail														
Overlap	Positive overlap														
Mounting position	Any														
Signal status display	LED														
Standard nominal flow rate G1/8	[l/min]	530			470			350		550	560	550	510		
Flow rate on manifold rail G1/8, front	[l/min]	490			440			320		500	510	500	470		
Flow rate on manifold rail G1/8, underneath	[l/min]	530			470			350		550	560	550	510		
Size	[mm]	14													
Port	1, 3, 5, 12/14, 82/84	On manifold rail													
	2, 4	On manifold rail													
Product weight	[g]	102			100			91		98	89	95			
Certification	c UL us – Recognized (OL)														
	c CSA us (OL)														
	RCM														
CE marking (see declaration of conformity) <sup>5)</sup>	To EU EMC Directive														
Corrosion resistance class CRC <sup>6)</sup>	2														

1) C=Normally closed/mid-position closed  
 2) U=Normally open/mid-position pressurised  
 3) E=mid-position exhausted  
 4) H=2x3/2-way valve in one housing with 1x normally closed and 1x normally open  
 5) For information about the area of use, see the EC declaration of conformity at: [www.festo.com/sp](http://www.festo.com/sp) → Certificates.  
 If the devices are subject to usage restrictions in residential, commercial or light-industrial environments, further measures for the reduction of the emitted interference may be necessary.  
 6) Corrosion resistance class CRC 2 to Festo standard FN 940070  
 Moderate corrosion stress. Indoor applications in which condensation can occur. External visible parts with primarily decorative surface requirements which are in direct contact with a normal industrial environment.

## Valve terminal VTUG with multi-pin plug connection and fieldbus interface

### Data sheet – Sub-base valves G1/8

Operating and environmental conditions			T32-A <sup>1)</sup>	T32-M <sup>2)</sup>	M32-A <sup>1)</sup>	M52-A <sup>1)</sup>	B52	M52-M <sup>2)</sup>	P53
Valve function			Compressed air to ISO 8573-1:2010 [7:4:4]						
Operating pressure	Internal pilot air supply	[bar]	1.5 ... 8	3.5 ... 8	2.5 ... 8	2.5 ... 8	1.5 ... 8	3 ... 8	3 ... 8
	External pilot air supply	[bar]	1.5 ... 10	-0.9 ... 10				-0.9 ... 8	-0.9 ... 10
Pilot pressure <sup>3)</sup>		[bar]	1.5 ... 8	2 ... 8	2.5 ... 8	2.5 ... 8	1.5 ... 8	3 ... 8	3 ... 8
Ambient temperature		[°C]	-5 ... +60						
Temperature of medium		[°C]	-5 ... +60						

- 1) Pneumatic spring  
 2) Mechanical spring  
 3) Minimum pilot pressure 50% of the operating pressure

Electrical data		
Electrical connection		Via sub-base
Operating voltage	[V DC]	24 ±10%
Power	[W]	1/0.4 (after 25 ms)
Duty cycle	[%]	100
Max. switching frequency	[Hz]	3
Degree of protection to EN 60529	Individual valve	IP67/IP65
	Valve terminal	IP40, IP67/IP65
	Valve terminal VTUG-VI-EX2	IP40, IP65, IP67, IP69K

- 1) Depending on the configuration selected

Safety data		
Max. positive test pulse with 0 signal	[µs]	1600
Max. negative test pulse with 1 signal	[µs]	3000
Shock resistance		Shock test with severity level 2 to FN 942017-5 and EN 60068-2-27
Vibration resistance		Transport application test with severity level 2 to FN 942017-4 and EN 60068-2-6

ATEX		
Type		VTUG-VI-EX2, VTUG-VI-EX3
ATEX category for gas		II 3G
Type of ignition protection for gas		Ex ec IIC T4 Gc
ATEX category for dust		II 3D
Type of ignition protection for dust		Ex tc IIIC T135°C Dc
Explosion protection certification outside the EU		EPL Dc (IEC-EX)
		EPL Gc (IEC-EX)
Explosion-proof ambient temperature	[°C]	5°C ≤ Ta ≤ +50°C, -5°C ≤ Ta ≤ +60°C
CE marking (see declaration of conformity)		In accordance with the EU EMC Directive, the EU Explosion Protection Directive (ATEX) and the EU RoHS Directive
Certificate issuing authority		IBExU16ATEXB021 X
		IECEX IBE 17.0003 X

Information on materials		
Housing		Wrought aluminium alloy
Seals		HNBR, NBR
Note on materials		RoHS-compliant

Valve switching times			T32-A <sup>1)</sup>	T32-M <sup>2)</sup>	M32-A <sup>1)</sup>	M52-A <sup>1)</sup>	B52	M52-M <sup>2)</sup>	P53
Valve function									
Switching time on	[ms]		10	13	13	13	-	10	15
Switching time off	[ms]		29	21	20	26	-	38	42
Switching time changeover	[ms]		-	-	-	-	9	-	25

- 1) Pneumatic spring  
 2) Mechanical spring

Data sheet – Sub-base valves G1/8

Dimensions

Download CAD data → [www.festo.com](http://www.festo.com)

Sub-base valve G1/8

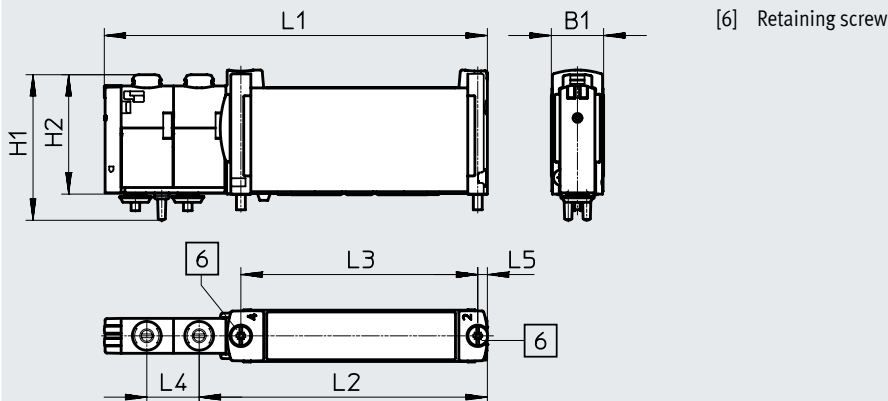

Type	B1	H1	H2	L1	L2	L3	L4	L5
VUVG-B14-...-F-1T1L	14.7	40.9	33.5	107.6	81	66.5	15.1	2.8
VUVG-B14-...-F-1T1L-EX2C								

Ordering data

Description	Part no.	Type	
<b>Sub-base valve G1/8</b>			
	<b>3/2-way valve</b>		
	External pilot air supply	Normally closed, reset method: pneumatic spring	8028235 VUVG-B14Z-M32C-AZT-F-1T1L
		Normally open, reset method: pneumatic spring	8028236 VUVG-B14Z-M32U-AZT-F-1T1L
	<b>2x 3/2-way valve</b>		
	External pilot air supply	Normally closed, reset method: pneumatic spring	573476 VUVG-B14-T32C-AZT-F-1T1L
		Normally open, reset method: pneumatic spring	573477 VUVG-B14-T32U-AZT-F-1T1L
		1x normally open, 1x normally closed, reset method: pneumatic spring	573478 VUVG-B14-T32H-AZT-F-1T1L
		Normally closed, reset method: mechanical spring	573479 VUVG-B14-T32C-MZT-F-1T1L
		Normally open, reset method: mechanical spring	573480 VUVG-B14-T32U-MZT-F-1T1L
		1x normally open, 1x normally closed, reset method: mechanical spring	573481 VUVG-B14-T32H-MZT-F-1T1L
	<b>5/2-way valve, single solenoid</b>		
	External pilot air supply	Reset method: pneumatic spring	573482 VUVG-B14-M52-AZT-F-1T1L
		Reset method: mechanical spring	573483 VUVG-B14-M52-MZT-F-1T1L
	<b>5/2-way valve, double solenoid</b>		
External pilot air supply		573484 VUVG-B14-B52-ZT-F-1T1L	
<b>5/3-way valve</b>			
External pilot air supply	Mid-position closed, reset method: mechanical spring	573485 VUVG-B14-P53C-ZT-F-1T1L	
	Mid-position pressurised, reset method: mechanical spring	573487 VUVG-B14-P53U-ZT-F-1T1L	
	Mid-position exhausted, reset method: mechanical spring	573486 VUVG-B14-P53E-ZT-F-1T1L	

Valve terminal VTUG with multi-pin plug connection and fieldbus interface

Data sheet – Sub-base valves G1/8

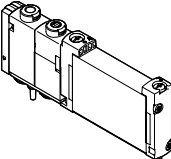
Ordering data		Description	Part no.	Type
<b>Sub-base valve G1/8</b>				
	<b>3/2-way valve</b>			
	External pilot air supply	Normally closed, reset method: pneumatic spring	<b>8041970</b>	VUVG-B14Z-M32C-AZT-F-1T1L-EX2C
		Normally open, reset method: pneumatic spring	<b>8041971</b>	VUVG-B14Z-M32U-AZT-F-1T1L-EX2C
	<b>2x 3/2-way valve</b>			
	External pilot air supply	Normally closed, reset method: pneumatic spring	<b>8041958</b>	VUVG-B14-T32C-AZT-F-1T1L-EX2C
		Normally open, reset method: pneumatic spring	<b>8041959</b>	VUVG-B14-T32U-AZT-F-1T1L-EX2C
		1x normally open, 1x normally closed, reset method: pneumatic spring	<b>8041960</b>	VUVG-B14-T32H-AZT-F-1T1L-EX2C
		Normally closed, reset method: mechanical spring	<b>8041961</b>	VUVG-B14-T32C-MZT-F-1T1L-EX2C
		Normally open, reset method: mechanical spring	<b>8041962</b>	VUVG-B14-T32U-MZT-F-1T1L-EX2C
		1x normally open, 1x normally closed, reset method: mechanical spring	<b>8041963</b>	VUVG-B14-T32H-MZT-F-1T1L-EX2C
	<b>5/2-way valve, single solenoid</b>			
	External pilot air supply	Reset method: pneumatic spring	<b>8041964</b>	VUVG-B14-M52-AZT-F-1T1L-EX2C
		Reset method: mechanical spring	<b>8041965</b>	VUVG-B14-M52-MZT-F-1T1L-EX2C
	<b>5/2-way valve, double solenoid</b>			
	External pilot air supply		<b>8041966</b>	VUVG-B14-B52-ZT-F-1T1L-EX2C
	<b>5/3-way valve</b>			
	External pilot air supply	Mid-position closed, reset method: mechanical spring	<b>8041967</b>	VUVG-B14-P53C-ZT-F-1T1L-EX2C
		Mid-position pressurised, reset method: mechanical spring	<b>8041969</b>	VUVG-B14-P53U-ZT-F-1T1L-EX2C
Mid-position exhausted, reset method: mechanical spring		<b>8041968</b>	VUVG-B14-P53E-ZT-F-1T1L-EX2C	



Data sheet – Sub-base valves G1/4

Function



2x 3/2C, 2x 3/2U, 2x 3/2H

5/2-way, single solenoid

5/2-way, double solenoid

5/3C, 5/3U, 5/3E

Circuit symbols → page 13

-  - Size 18 mm
-  - Flow rate  
800 ... 1000 l/min
-  - Voltage  
24 V DC

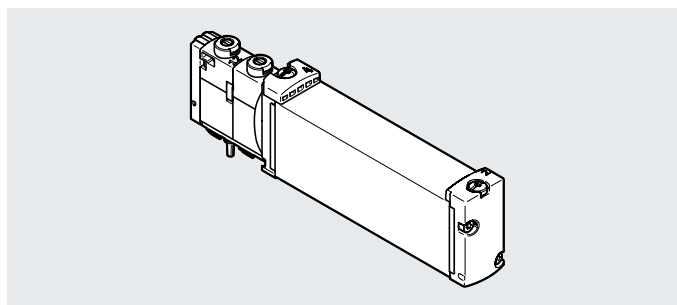

General technical data												
Valve function	T32-A			T32-M			M52-R	B52	M52-M	P53		
Normal position	C <sup>1)</sup>	U <sup>2)</sup>	H <sup>4)</sup>	C <sup>1)</sup>	U <sup>2)</sup>	H <sup>4)</sup>	–	–	–	C <sup>1)</sup>	U <sup>2)</sup>	E <sup>3)</sup>
Stable position	Monostable						Bistable		Monostable			
Reset method: pneumatic spring	Yes			No			Yes <sup>5)</sup>		–		No	
Reset method: mechanical spring	No			Yes			Yes <sup>5)</sup>		–		Yes	
Vacuum operation at port 1	No			With external pilot air								
Design	Piston spool											
Sealing principle	Soft											
Actuation type	Electric											
Type of control	Piloted											
Pilot air supply	External											
Exhaust air function	Can be throttled											
Manual override	Choice of non-detenting, covered, non-detenting/detenting or detenting											
Type of mounting	On manifold rail											
Mounting position	Any											
Overlap	Positive overlap						Indeterminate overlap	Over-lap	Indeterminate overlap	Overlap	Indeterminate overlap	
Signal status display	LED											
Flow rate on manifold rail G1/4, front	[l/min]	800	800	950	1000	950	900					
Size	[mm]	18										
Port	1, 3, 5, 12/14, 82/84	On manifold rail										
	2, 4	On manifold rail										
Product weight	[g]	145	147	138	145	138	140					
Certification	c UL us – Recognized (OL)											
	c CSA us (OL)											
	RCM											
CE marking (see declaration of conformity)	To EU EMC Directive <sup>6)</sup>											
Corrosion resistance class CRC <sup>7)</sup>	2											

1) C=Normally closed/mid-position closed

2) U=Normally open/mid-position pressurised

3) E=mid-position exhausted

4) H=2x3/2-way valve in one housing with 1x normally closed and 1x normally open

5) Combined reset method

6) For information about the area of use, see the EC declaration of conformity at: [www.festo.com/sp](http://www.festo.com/sp) → Certificates.

If the devices are subject to usage restrictions in residential, commercial or light-industrial environments, further measures for the reduction of the emitted interference may be necessary.

7) Corrosion resistance class CRC 2 to Festo standard FN 940070

Moderate corrosion stress. Indoor applications in which condensation can occur. External visible parts with primarily decorative surface requirements which are in direct contact with a normal industrial environment.

Valve terminal VTUG with multi-pin plug connection and fieldbus interface

Data sheet – Sub-base valves G1/4

Operating and environmental conditions			T32-A <sup>1)</sup>	T32-M <sup>2)</sup>	M52-R <sup>3)</sup>	B52	M52-M <sup>2)</sup>	P53
Valve function								
Operating medium			Compressed air to ISO 8573-1:2010 [7:4:4]					
Pilot medium			Compressed air to ISO 8573-1:2010 [7:4:4]					
Note on the operating/pilot medium			Lubricated operation possible (in which case lubricated operation will always be required)					
Operating pressure	Internal pilot air supply	[bar]	1.5 ... 8	2 ... 8	2.5 ... 8	1.5 ... 8	3 ... 8	3 ... 8
	External pilot air supply	[bar]	1.5 ... 10	-0.9 ... 10			-0.9 ... 8	-0.9 ... 10
Pilot pressure <sup>4)</sup>		[bar]	1.5 ... 8	2 ... 8	2.5 ... 8	1.5 ... 8	3 ... 8	3 ... 8
Ambient temperature		[°C]	-5 ... +60					
Temperature of medium		[°C]	-5 ... +60					

- 1) Pneumatic spring
- 2) Mechanical spring
- 3) Mixed, pneumatic/mechanical spring
- 4) Minimum pilot pressure 50% of the operating pressure

Electrical data		
Electrical connection		Via sub-base
Operating voltage	[V DC]	24 ±10%
Power	[W]	1
Duty cycle	[%]	100
Max. switching frequency	[Hz]	3
Degree of protection to EN 60529 <sup>1)</sup>	Individual valve	IP65, IP67
	Valve terminal VTUG	IP40, IP67/IP65, IP69K
	Valve terminal VTUG-VI-EX2	IP20, IP65

- 1) Depending on the configuration selected

Safety data		
Max. positive test pulse with 0 signal	[µs]	1600
Max. negative test pulse with 1 signal	[µs]	3000
Shock resistance	Shock test with severity level 2 to FN 942017-5 and EN 60068-2-27	
Vibration resistance	Transport application test with severity level 2 to FN 942017-4 and EN 60068-2-6	

Information on materials	
Housing	Wrought aluminium alloy
Seals	HNBR, NBR
Note on materials	RoHS-compliant

Valve switching times			T32-A <sup>1)</sup>	T32-M <sup>2)</sup>	M52-R <sup>3)</sup>	B52	M52-M <sup>2)</sup>	P53
Valve function								
Switching time on	[ms]		15	25	20	–	13	20
Switching time off	[ms]		35	33	35	–	50	57
Switching time changeover	[ms]		–	–	–	15	–	31

- 1) Pneumatic spring
- 2) Mechanical spring
- 3) Mixed, pneumatic/mechanical spring

Data sheet – Sub-base valves G1/4

Dimensions

Download CAD data → [www.festo.com](http://www.festo.com)

Sub-base valve G1/4

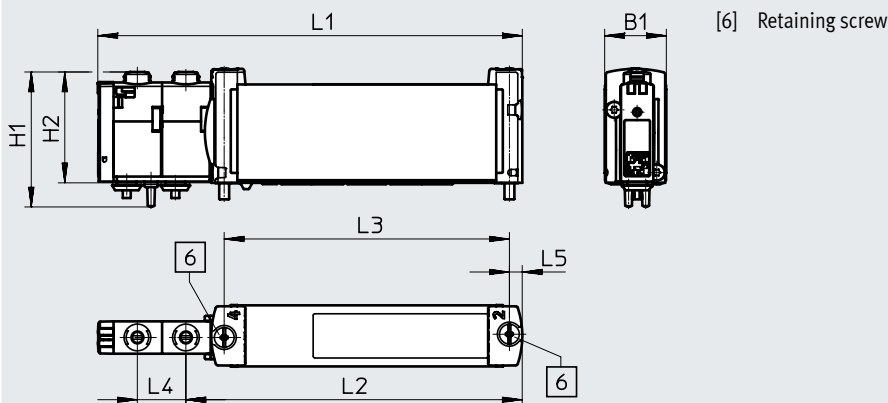

Type	B1	H1	H2	L1	L2	L3	L4	L5
VUVG-B18-...-F-1T1L	18.7	40.9	33.6	128.6	101.9	86.4	14.7	3.9

Ordering data

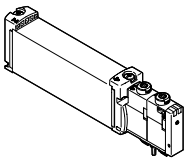
Description	Part no.	Type
<b>Sub-base valve G1/4</b>		
 <p><b>2x 3/2-way valve</b></p> <p>External pilot air supply</p>	Normally closed, reset method: pneumatic spring	8004885 VUVG-B18-T32C-AZT-F-1T1L
	Normally open, reset method: pneumatic spring	8004886 VUVG-B18-T32U-AZT-F-1T1L
	1x normally open, 1x normally closed, reset method: pneumatic spring	8004887 VUVG-B18-T32H-AZT-F-1T1L
	Normally closed, reset method: mechanical spring	8004888 VUVG-B18-T32C-MZT-F-1T1L
	Normally open, reset method: mechanical spring	8004889 VUVG-B18-T32U-MZT-F-1T1L
	1x normally open, 1x normally closed, reset method: mechanical spring	8004890 VUVG-B18-T32H-MZT-F-1T1L
<b>5/2-way valve, single solenoid</b>		
External pilot air supply	Reset method: pneumatic/mechanical spring	8004891 VUVG-B18-M52-RZT-F-1T1L
	Reset method: mechanical spring	8004892 VUVG-B18-M52-MZT-F-1T1L
<b>5/2-way valve, double solenoid</b>		
External pilot air supply		8004893 VUVG-B18-B52-ZT-F-1T1L
<b>5/3-way valve</b>		
External pilot air supply	Mid-position closed, reset method: mechanical spring	8004894 VUVG-B18-P53C-ZT-F-1T1L
	Mid-position exhausted, reset method: mechanical spring	8004895 VUVG-B18-P53E-ZT-F-1T1L
	Mid-position pressurised, reset method: mechanical spring	8004896 VUVG-B18-P53U-ZT-F-1T1L

## Valve terminal VTUG with multi-pin plug connection and fieldbus interface

### Data sheet – Manifold rail VABM

General technical data		Size 10	Size 14	Size 18
Manifold rail				
Short type code		VABM		
Grid dimension	[mm]	10.5	16	19
Mounting position		Any		
Connection type		Semi in-line/sub-base		
Max. no. of valve positions		24		
Port	12/14	M5	M5	G1/8
	82/84	M5	M5	G1/8
	2, 4	M5 or M7	G1/8	G1/4
	1, 3, 5	G1/8	G1/4	G3/8
Storage temperature	[°C]	-20 ... 60		
Certification		c UL us – Recognized (OL)		
		c CSA us (OL)		
CE marking (see declaration of conformity) <sup>1)</sup>		To EU EMC Directive		
Corrosion resistance class CRC <sup>2)</sup>		2		

1) For information about the area of use, see the EC declaration of conformity at: [www.festo.com/sp](http://www.festo.com/sp) → Certificates.

If the devices are subject to usage restrictions in residential, commercial or light-industrial environments, further measures for the reduction of the emitted interference may be necessary.

2) Corrosion resistance class CRC 2 to Festo standard FN 940070

Moderate corrosion stress. Indoor applications in which condensation can occur. External visible parts with primarily decorative surface requirements which are in direct contact with a normal industrial environment.

Weight [g]											
Valve positions	4	5	6	7	8	9	10	12	16	20	24
VABM-L1-10G-G18-...	329	363	397	431	465	499	533	601	737	873	1009
VABM-L1-10HW-G18-...	388	426	464	502	540	578	616	692	844	996	1148
VABM-L1-14G-G14-...	879	990	1101	1212	1323	1434	1545	1767	2211	2655	3099
VABM-L1-14W-G14-...	839	940	1041	1142	1243	1344	1445	1647	2051	2455	2859
VABM-L1-18G-G38-...	1461	1661	1861	2061	2261	2461	2661	3061	3861	4661	5461
VABM-L1-18W-G38-...	1369	1546	1723	1900	2077	2254	2431	2785	3493	4201	4909

Materials	
Manifold rail	Wrought aluminium alloy
Note on materials	RoHS-compliant

Data sheet – Manifold rail VABM

Dimensions – Example of valve terminal with I-Port interface

Download CAD data → [www.festo.com](http://www.festo.com)

Outlet orientation of electrical components on top

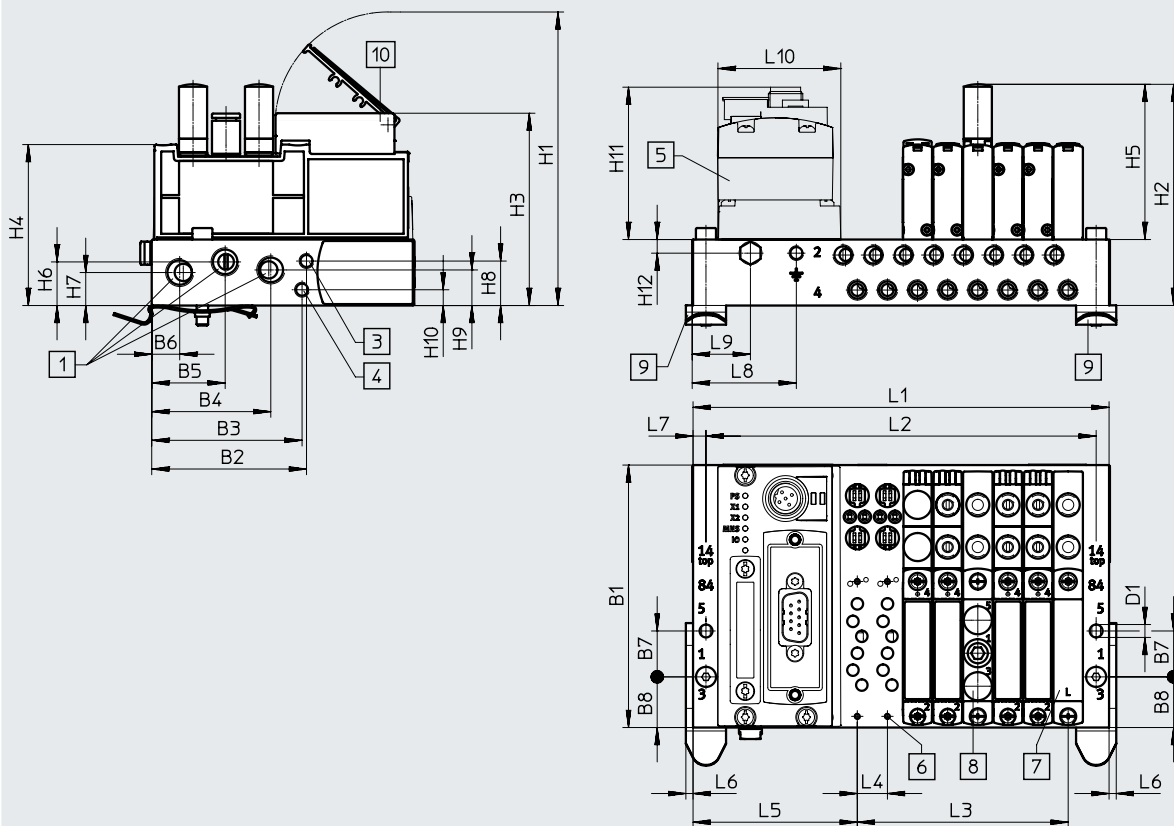

- [1] Port 1, 3 and 5: size 10: G1/8 (at both ends), size 14: G1/4 (at both ends), size 18: G3/8 (at both ends)
- [2] Ports 2 and 4: size 10: M2, size 14: M2.5, size 18: M3
- [3] Ports 12/14: sizes 10 and 14: M5 (at both ends), size 18: G1/8 (at both ends)
- [4] Ports 82/84: sizes 10 and 14: M5 (at both ends), size 18: G1/8 (at both ends)
- [5] CTEU CANopen
- [6] Valves/cover plate/supply plate mounting on manifold block: size 10: M2, size 14: M2.5, size 18: M3
- [7] Cover plate
- [8] Supply plate, port 1, 3 and 5: size 10: M7, size 14: G1/8, size 18: G1/4
- [9] H-rail mounting
- [10] Inscription label holder

Type	No. of valve positions	Size 10																
		B1	B2	B3	B4	B5	B6	B7	B8	D1 Ø	H1	H2	H3	H4	H5	H6	H7	H8
VABM	4-24	91.5	54	52.4	41.5	25.6	9.8	16	17.7	4.5	102.3	77.1	67	56.1	54.1	15.2	11.5	15.5

Type	No. of valve positions	Size 10										
		H9	H10	H11	H12	L4	L5	L6	L7	L8	L9	L10
VABM	4-24	12.4	5.5	54.8	4.8	10.5	57.3	2.5	4.5	36	20	42.5

Type	No. of valve positions	Size 14																
		B1	B2	B3	B4	B5	B6	B7	B8	D1 Ø	H1	H2	H3	H4	H5	H6	H7	H8
VABM	4-24	110	70	59.3	56.5	36.5	16	20	26.5	4.5	113.1	95.1	77.7	68.6	61.3	18.7	15.7	28.7

Valve terminal VTUG with multi-pin plug connection and fieldbus interface

Data sheet – Manifold rail VABM

Type	No. of valve positions	Size 14										
		H9	H10	H11	H12	L4	L5	L6	L7	L8	L9	L10
VABM	4-24	13.2	23.7	54.8	5.1	16	60.6	2	5	10	25.5	42.5

Type	No. of valve positions	Size 18																
		B1	B2	B3	B4	B5	B6	B7	B8	D1 ø	H1	H2	H3	H4	H5	H6	H7	H8
VABM	4-24	131	90.5	77.3	72.3	47.5	21.5	26	34	5.5	121.5	95.2	-	77.4	52.7	23.6	18.7	35.1

Type	No. of valve positions	Size 18										
		H9	H10	H11	H12	L4	L5	L6	L7	L8	L9	L10
VABM	4-24	14.5	27	54.8	13.8	19	63.5	2	5	10	27	42.5

Type	No. of valve positions	Size 10			Size 14			Size 18		
		L1	L2	L3	L1	L2	L3	L1	L2	L3
VABM	4	103	94	31.5	128	118	48	139.5	129.5	57
	5	113.5	104.5	42	144	134	64	158.5	148.5	76
	6	124	115	52.5	160	150	80	177.5	167.5	95
	7	134.5	125.5	63	176	166	96	196.5	186.5	114
	8	145	136	73.5	192	182	112	215.5	205.5	133
	9	155.5	146.5	84	208	198	128	234.5	224.5	152
	10	166	157	94.5	224	214	144	253.5	243.5	171
	12	187	178	115.5	256	246	176	291.5	281.5	209
	16	229	220	157.5	320	310	240	367.5	357.5	285
	20	271	262	199.5	384	374	304	443.5	433.5	361
	24	313	304	241.5	448	438	368	519.5	509.5	437

Data sheet – Manifold rail VABM

Dimensions – Example of valve terminal with I-Port interface

Download CAD data → [www.festo.com](http://www.festo.com)

Outlet orientation of electrical components to the left

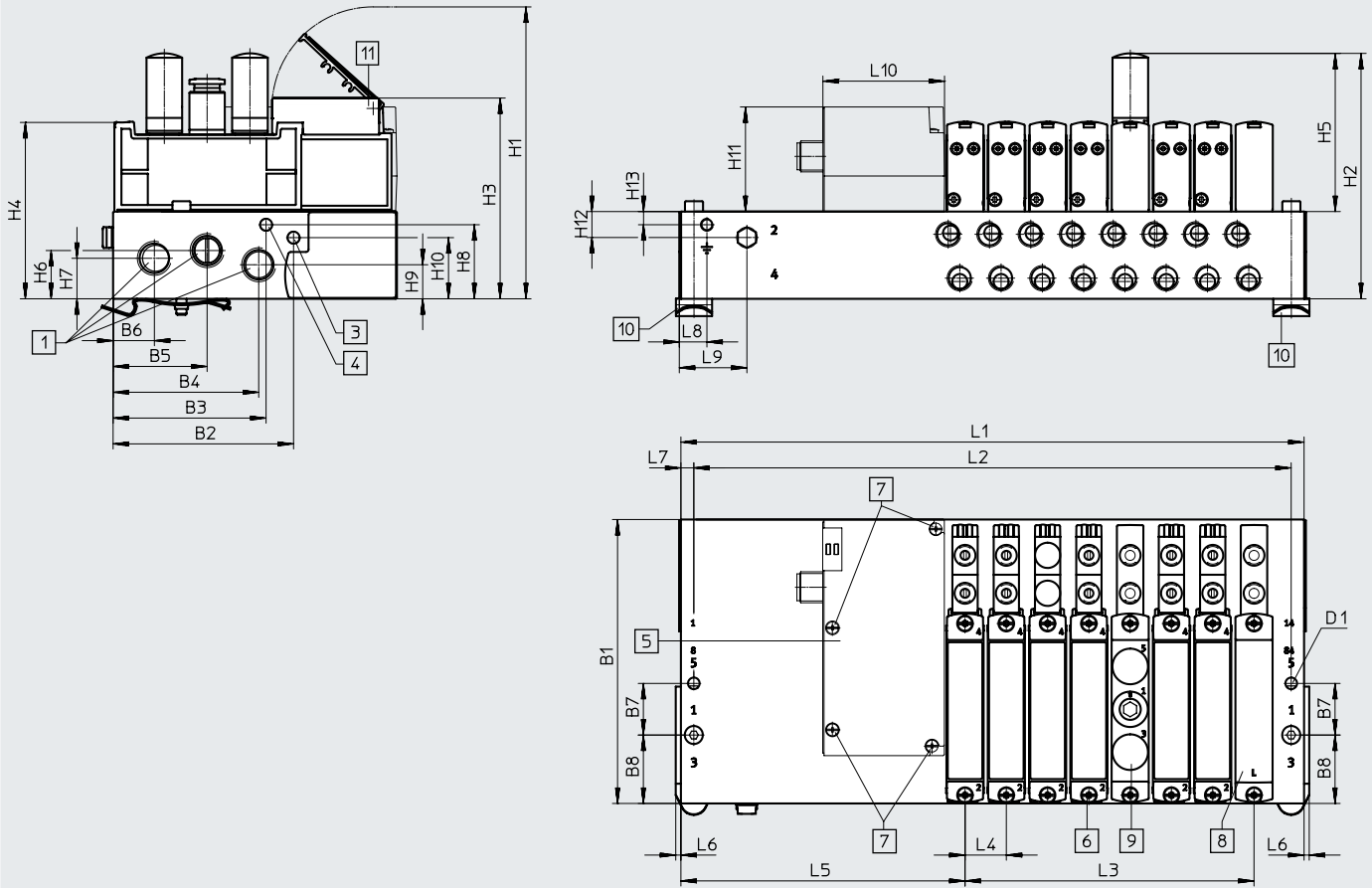

- [1] Port 1, 3 and 5: size 10: G1/8 (at both ends), size 14: G1/4 (at both ends), size 18: G3/8 (at both ends)
- [2] Ports 12/14: sizes 10 and 14: M5 (at both ends), size 18: G1/8 (at both ends)
- [3] Ports 8/2/8/4: sizes 10 and 14: M5 (at both ends), size 18: G1/8 (at both ends)
- [4] Electrical connection I-Port interface/IO-Link
- [5] Valves/cover plate/supply plate mounting on manifold block: size 10: M2, size 14: M2.5, size 18: M3
- [6] Electrical interface
- [7] Cover plate
- [8] Supply plate, port 1, 3 and 5: size 10: M7, size 14: G1/8, size 18: G1/4
- [9] H-rail mounting
- [10] Inscription label holder
- [11]

Type	No. of valve positions	Size 10																
		B1	B2	B3	B4	B5	B6	B7	B8	D1∅	H1	H2	H3	H4	H5	H6	H7	H8
VABM	4-24	91.5	54	52.4	41.5	25.6	9.8	16	17.7	4.5	102.3	77.1	67	56.1	54.1	15.2	11.5	15.5

Type	No. of valve positions	Size 10											
		H9	H10	H11	H12	H13	L4	L5	L6	L7	L8	L9	L10
VABM	4-24	12.4	5.5	40.8	10.1	5.1	10.5	106.8	2.5	4.5	36	75	47.1

Type	No. of valve positions	Size 14																
		B1	B2	B3	B4	B5	B6	B7	B8	D1 ∅	H1	H2	H3	H4	H5	H6	H7	H8
VABM	4-24	110	70	59.3	56.5	36.5	16	20	26.5	4.5	113.1	95.1	77.7	68.6	61.3	18.7	15.7	28.7

Type	No. of valve positions	Size 14											
		H9	H10	H11	H12	H13	L4	L5	L6	L7	L8	L9	L10
VABM	4-24	13.2	23.7	40.8	10.1	5.1	16	110.1	2	5	10	75	47.1

Valve terminal VTUG with multi-pin plug connection and fieldbus interface

Data sheet – Manifold rail VABM

Type	No. of valve positions	Size 18																
		B1	B2	B3	B4	B5	B6	B7	B8	D1∅	H1	H2	H3	H4	H5	H6	H7	H8
VABM	4-24	131	90.5	77.3	72.3	47.5	21.5	26	34	5.5	121.5	95.2	-	77.4	52.7	23.6	18.7	35.1

Type	No. of valve positions	Size 18												
		H9	H10	H11	H12	H13	L4	L5	L6	L7	L8	L9	L10	
VABM	4-24	14.5	27	40.8	13.8	10	19	105	2	5	10	27	47.1	

Type	No. of valve positions	Size 10			Size 14			Size 18		
		L1	L2	L3	L1	L2	L3	L1	L2	L3
VABM	4	152.5	143.5	31.5	177.5	167.5	48	181	171	57
	5	163	154	42	193.5	183.5	64	200	190	76
	6	173.5	164.5	52.5	209.5	199.5	80	219	209	95
	7	184	175	63	225.5	215.5	96	238	228	114
	8	194.5	185.5	73.5	241.5	231.5	112	257	247	133
	9	205	196	84	257.5	247.5	128	276	266	152
	10	215.5	206.5	94.5	273.5	263.5	144	295	285	171
	12	236.5	227.5	115.5	305.5	295.5	176	333	323	209
	16	278.5	269.5	157.5	369.5	359.5	240	409	399	285
	20	321	311.5	199.5	433.5	423.5	304	485	475	361
24	362.5	353.5	241.5	497.5	487.5	368	561	551	437	

 **Note**  
The dimensions for size 10 are the same as the dimensions for the manifold rail with interlock.



Data sheet – Manifold rail VABM

Dimensions – Example of control cabinet installation for valve terminal

Download CAD data → [www.festo.com](http://www.festo.com)

Outlet orientation of electrical components on top

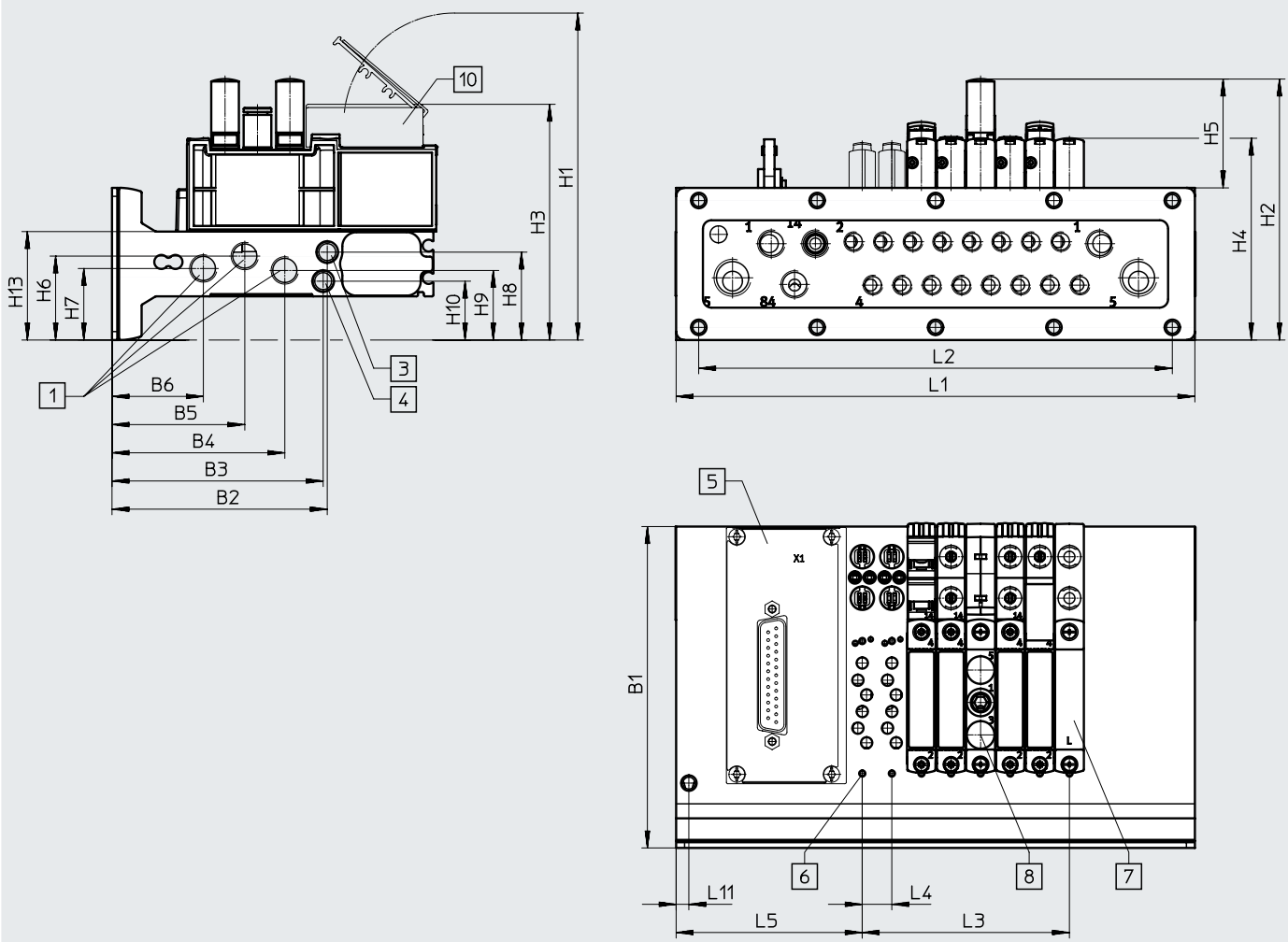

- [1] Port 1, 3 and 5: size 10: G1/8, G1/4, size 14: G3/8, G1/4
- [2] Port 2: size 10: G1/8, G1/4, size 14: G3/8, G1/4
- [3] Port 12/14: size 10: M5 (at both ends), size 14: M7 (at both ends)
- [4] Port 82/84: size 10: M5 (at both ends), size 14: M7 (at both ends)
- [5] Electrical connection
- [6] Valves/cover plate/supply plate mounting on manifold block: M2
- [7] Cover plate
- [8] Supply plate, port 1, 3 and 5: M7
- [9] Port 10: size 10: M5 (at both ends), size 14: M7 (at both ends)
- [10] Inscription label holder

Type	No. of valve positions	Size 10									
		B1	B2	B3	B4	B5	B6	H1	H2	H3	H4
VABM	4-24	114	76.4	74.9	61.3	47.1	32.4	116	92.6	84	71.6

Type	No. of valve positions	Size 10									
		H5	H6	H7	H8	H9	H10	H13	L4	L5	L11
VABM	4-24	38.6	29.8	25.4	31.2	24.7	20.9	38.5	10.5	66	4.5

Type	No. of valve positions	Size 14									
		B1	B2	B3	B4	B5	B6	H1	H2	H3	H4
VABM	4-24	132	93	80.8	76.5	55.5	36.1	111.3	101.7	77.6	85.1

Type	No. of valve positions	Size 14									
		H5	H6	H7	H8	H9	H10	H13	L4	L5	L11
VABM	4-24	34.9	35.2	30.3	39.3	30.3	45	50.3	16	72.6	4.5

Data sheet – Manifold rail VABM

Dimensions – Example of control cabinet installation for valve terminal

Download CAD data → [www.festo.com](http://www.festo.com)

Electrical outlet orientation: top, with shut-off function (hot swap)

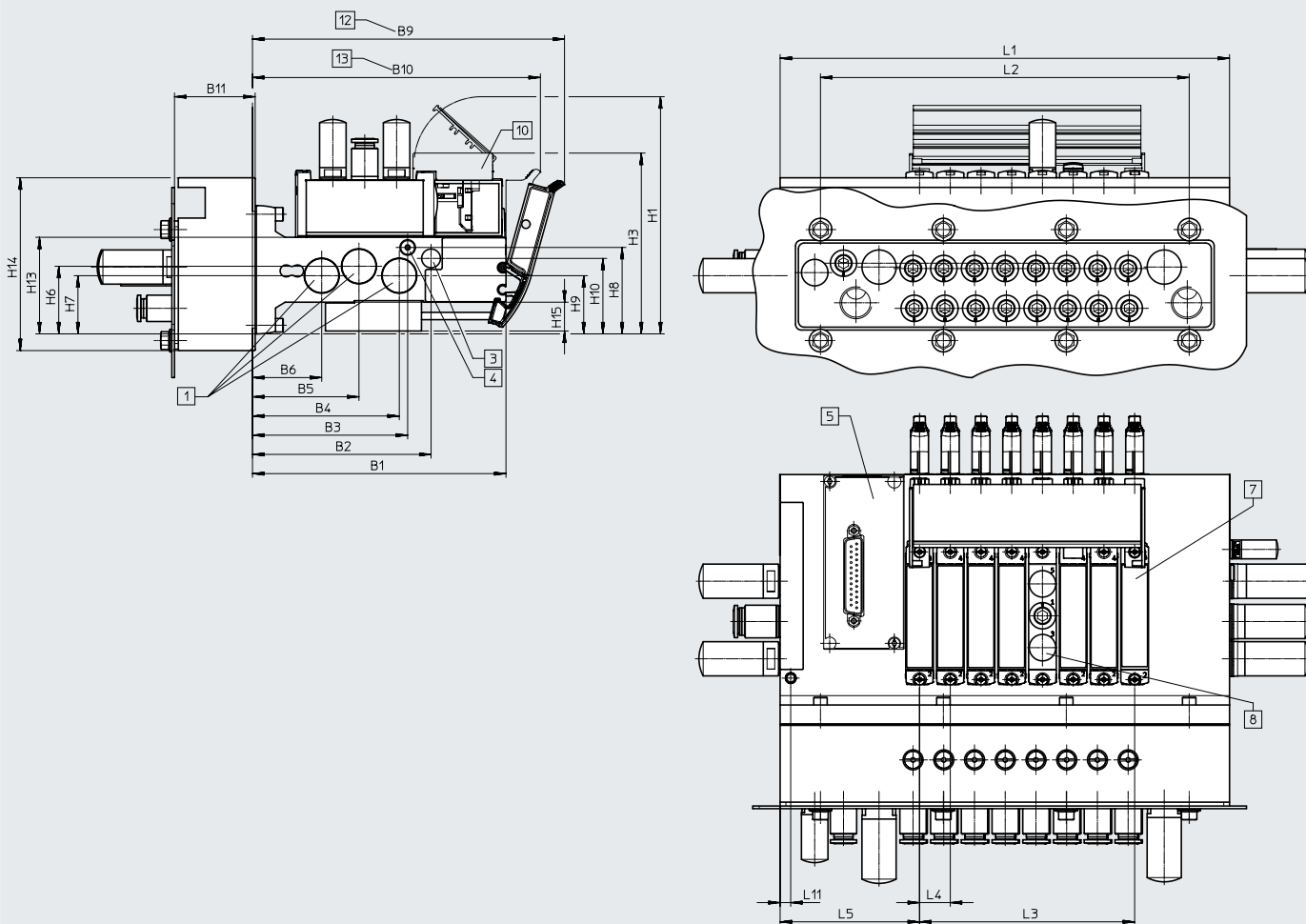

- [1] Port 1, 3 and 5: size 10: G1/8, G1/4, size 14: G3/8, G1/4
- [2] Port 12/14: size 10: M5 (at both ends), size 14: M7 (at both ends)
- [3] Port 82/84: size 10: M5 (at both ends), size 14: M7 (at both ends)
- [4] Electrical connection
- [5] Cover plate
- [6] Supply plate, port 1, 3 and 5: M7
- [7] Inscription label holder
- [8] VTUG 10: With seal and stainless steel plate
- [9] VTUG 14: With seal and stainless steel plate, hot swap 1 and 2/4
- [10] With seal and stainless steel plate

Type	No. of valve positions	Size 10										
		B1	B2	B3	B4	B5	B6	B9	B10	B11	H1	H3
VABM	4-24	114	76.4	74.9	61.3	47.1	32.4	142	132	–	114	82

Type	No. of valve positions	Size 10										
		H6	H7	H8	H9	H10	H13	H14	H15	L4	L5	L11
VABM	4-24	29.8	25.4	20.9	24.7	31.2	38.5	–	15	10.5	66	5.5

Type	No. of valve positions	Size 14										
		B1	B2	B3	B4	B5	B6	B9	B10	B11	H1	H3
VABM	4-24	132	93	80.8	76.5	55.5	36.1	163	150.4	42	123.5	93.9

Type	No. of valve positions	Size 14										
		H6	H7	H8	H9	H10	H13	H14	H15	L4	L5	L11
VABM	4-24	35.2	30.3	45	30.3	39.3	50.3	90	15	16	72.6	5.5

Data sheet – Manifold rail VABM

Number of valve positions	L1	L2	L3
VABM-L1-10HWS1-G18-4-GR	116.2	84	31.5
VABM-L1-10HWS1-G18-8-GR	158.2	126	73.5
VABM-L1-10HWS2-G18-8-GR	184	168	73.5
VABM-L1-10HWS2-G18-12-GR	226	210	115.5
VABM-L1-10HWS2-G18-16-GR	268	252	157.5
VABM-L1-10HWS2-G18-24-GR	352	336	241.5
VABM-L1-10HWS2-H-G18-8-GR	184	168	73.5
VABM-L1-10HWS2-H-G18-12-GR	226	210	115.5
VABM-L1-10HWS2-H-G18-16-GR	268	252	157.5
VABM-L1-10HWS2-H-G18-24-GR	352	336	241.5
VABM-L1-14HWS1-G14-4-GR	135	64	48
VABM-L1-14HWS1-G14-8-GR	199	128	112
VABM-L1-14HWS2-G14-8-GR	234	192	112
VABM-L1-14HWS2-G14-12-GR	298	256	176
VABM-L1-14HWS2-G14-16-GR	362	320	240
VABM-L1-14HWS2-G14-24-GR	490	448	368
VABM-L1-14HWS2-H-G14-8-GR	234	192	112
VABM-L1-14HWS2-H-G14-12-GR	298	256	176
VABM-L1-14HWS2-H-G14-16-GR	362	320	240
VABM-L1-14HWS2-H-G14-24-GR	490	448	368

Data sheet – Manifold rail VABM

**Dimensions – Manifold rail outlet orientation: front**

Download CAD data → [www.festo.com](http://www.festo.com)

Size 10, I-Port interface on top

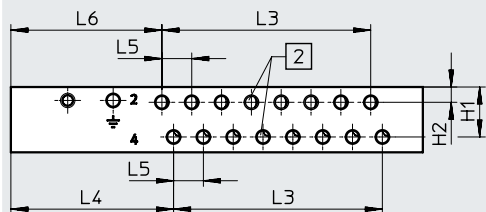
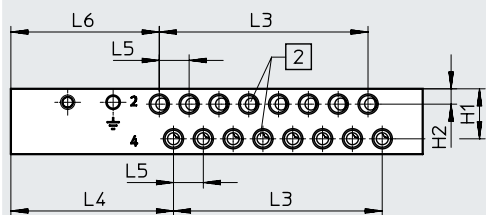

[2] Port 2 and 4

Size 14, I-Port interface on top

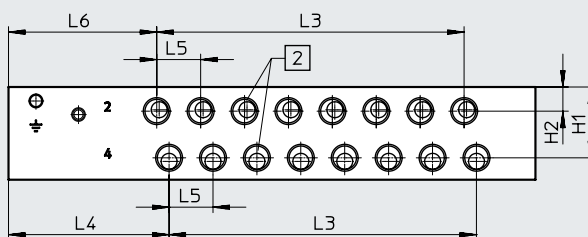

[2] Port 2 and 4

Size 18, I-Port interface on top

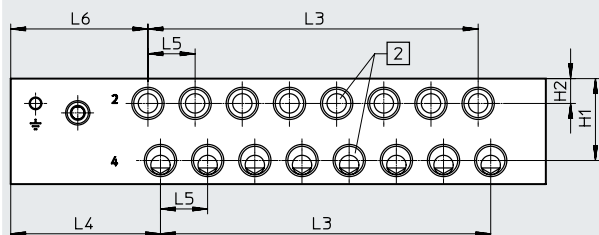

[2] Port 2 and 4

Size 10, 14, 18, I-Port interface on the side

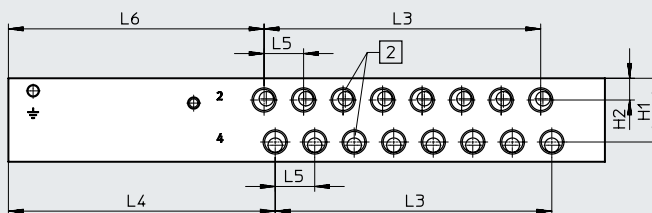

[2] Port 2 and 4

Size	Port 2 and 4	Manifold rail with I-Port interface on top				
		H1	H2	L4	L5	L6
10	M7 thread	17.6	5.4	57.3	10.5	52.3
	M5 thread					53.2
14	G1/8 thread	25.8	8.8	58.5	16	54
18	G1/4 thread	33	10	60.3	19	55.3

Size	Port 2 and 4	Manifold rail with I-Port interface on the side				
		H1	H2	L4	L5	L6
10	M7 thread	17.6	5.4	106.8	10.5	101.8
	M5 thread					102.7
14	G1/8 thread	25.8	8.8	108	16	103.5
18	G1/4 thread	33	10	101.8	19	96.8

Data sheet – Manifold rail VABM

Type	Number of valve positions	Size 10	Size 14	Size 18
		L3	L3	L3
VABM	4	31.5	48	57
	5	42	64	76
	6	52.5	80	95
	7	63	96	114
	8	73.5	112	133
	9	84	128	152
	10	94.5	144	171
	12	115.5	176	209
	16	157.5	240	285
	20	199.5	304	361
	24	241.5	368	437

Data sheet – Manifold rail VABM

Dimensions – Manifold rail outlet orientation underneath

Download CAD data → [www.festo.com](http://www.festo.com)

Control cabinet installation

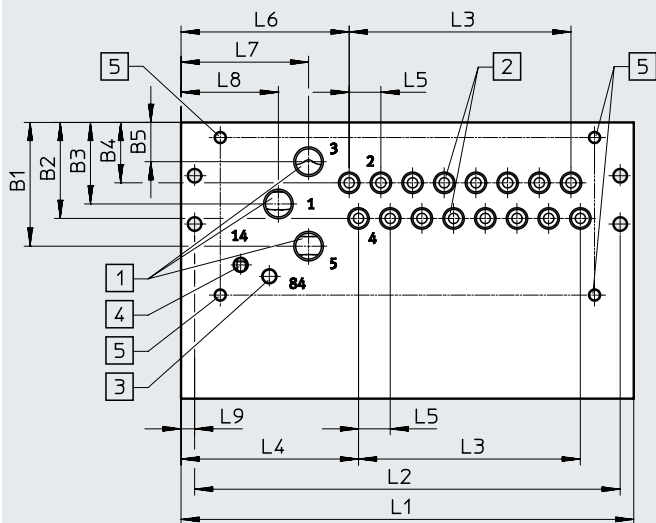

**Note**  
 Dimensions of the manifold rail with I-Port interface on the side for control cabinet installation  
 → page 167

- [1] Port 1, 3 and 5: size 10: G1/8, size 14: G1/4, size 18: G3/8
- [2] Port 2 and 4: size 10: M5/M7, size 14: G1/8, size 18: G1/4
- [3] Port 82/84: size 10 and 14: M5, size 18: G1/8
- [4] Port 12/14: size 10 and 14: M5, size 18: G1/8
- [5] Mounting holes, outlet orientation underneath: M4x8

Type	Manifold rail with I-Port interface on top, size 10										
	B1	B2	B3	B4	B5	L4	L5	L6	L7	L8	L9
VABM	41	31.8	27	20	13	58.8	10.5	55.7	42.3	32.3	4.5

Type	Manifold rail with I-Port interface on top, size 14										
	B1	B2	B3	B4	B5	L4	L5	L6	L7	L8	L9
VABM	53.5	45.1	35.2	27.8	17	58.5	16	58.5	43	33	5

Type	Manifold rail with I-Port interface on top, size 18										
	B1	B2	B3	B4	B5	L4	L5	L6	L7	L8	L9
VABM	75	59.5	48.5	35.7	22	60.3	19	60.3	40	40	5

Type	No. of valve positions	Size 10			Size 14			Size 18		
		L1 +5	L2 +5	L3	L1	L2	L3	L1	L2	L3
VABM	4	103	94	31.5	128	118	48	139.5	129.5	57
	5	113.5	104.5	42	144	134	64	158.5	148.5	76
	6	124	115	52.5	160	150	80	177.5	167.5	95
	7	134.5	125.5	63	176	166	96	196.5	186.5	114
	8	145	136	73.5	192	182	112	215.5	205.5	133
	9	155.5	146.5	84	208	198	128	234.5	224.5	152
	10	166	157	94.5	224	214	144	253.5	243.5	171
	12	187	178	115.5	256	246	176	291.5	281.5	209
	16	229	220	157.5	320	310	240	367.5	357.5	285
	20	271	262	199.5	384	374	304	443.5	433.5	361
	24	313	304	241.5	448	438	368	519.5	509.5	437

Data sheet – Manifold rail VABM

Type	Manifold rail with I-Port interface, size 10										
	B1	B2	B3	B4	B5	L4	L5	L6	L7	L8	L9
VABM	41	31.8	27	20	13	108.3	10.5	105.2	91.8	81.8	4.5

Type	Manifold rail with I-Port interface, size 14										
	B1	B2	B3	B4	B5	L4	L5	L6	L7	L8	L9
VABM	53.5	45.1	35.2	27.8	17	108	16	108	92.5	82.5	5

Type	Manifold rail with I-Port interface, size 18										
	B1	B2	B3	B4	B5	L4	L5	L6	L7	L8	L9
VABM	75	59.5	48.5	35.7	22	101.8	19	101.8	81.5	81.5	5

Type	No. of valve positions	Manifold rail with I-Port interface Size 10			Manifold rail with I-Port interface Size 14			Manifold rail with I-Port interface Size 18		
		L1 +5	L2 +5	L3	L1	L2	L3	L1	L2	L3
		VABM	4	152.5	143.5	31.5	177.5	167.5	48	181
	5	163	154	42	193.5	183.5	64	200	190	76
	6	173.5	164.5	52.5	209.5	199.5	80	219	209	95
	7	184	175	63	225.5	215.5	96	238	228	114
	8	194.5	185.5	73.5	241.5	231.5	112	257	247	133
	9	205	196	84	257.5	247.5	128	276	266	152
	10	215.5	206.5	94.5	273.5	263.5	144	295	285	171
	12	236.5	227.5	115.5	305.5	295.5	176	333	323	209
	16	278.5	269.5	157.5	369.5	359.5	240	409	399	285
	20	320.5	311.5	199.5	433.5	423.5	304	485	475	361
	24	362.5	353.5	241.5	497.5	487.5	368	561	551	437

Valve terminal VTUG with multi-pin plug connection and fieldbus interface

Data sheet – Manifold rail VABM

Dimensions – Manifold rail outlet orientation: front

Download CAD data → [www.festo.com](http://www.festo.com)

Control cabinet installation/control cabinet installation with shut-off function (hot swap)

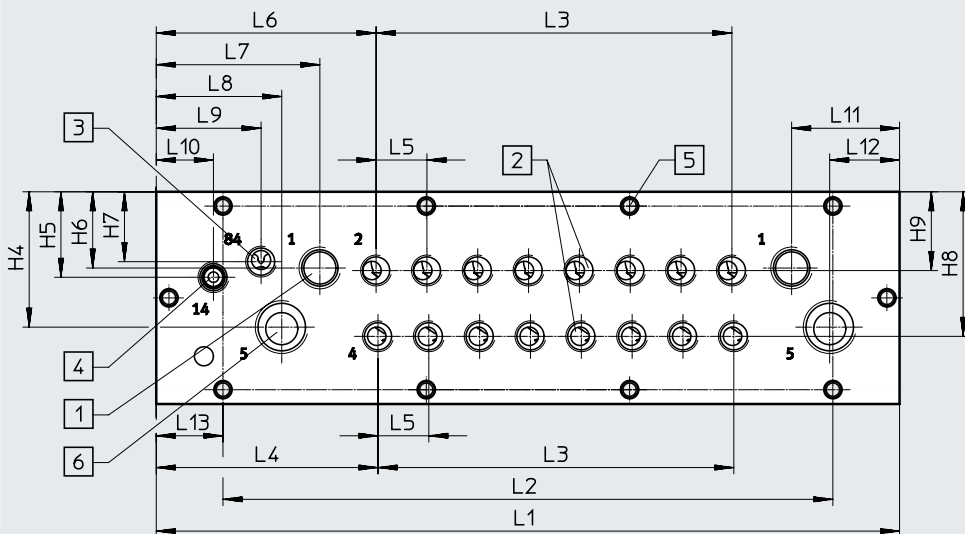

- [1] Port 1, 3 and 5: size 10: G1/8, size 14: G1/4
- [2] Port 2 and 4: size 10: M5/M7, size 14: G1/8
- [3] Port 82/84: size 10 and 14: M5
- [4] Port 12/14: size 10 and 14: M5
- [5] Mounting holes, outlet orientation underneath: M5

Type	Size 10															
	B1	B2	B3	B4	B5	B6	L4	L5	L6	L7	L8	L9	L10	L11	L12	L13
VABM-L1-10HWS1	111.5	73.9	72.4	58.8	44.6	29.9	69.8	10.5	63	33.8	20	42	49.4	33.8	20	16.1
VABM-L1-10HWS2																8

Type	Size 10								
	H1	H2	H3	H4	H5	H6	H7	H8	H9
VABM-L1-10HWS1	54	15.5	23	31.9	19.8	19.8	34.3	34.5	19.1
VABM-L1-10HWS2									

Type	Size 14															
	B1	B2	B3	B4	B5	B6	L4	L5	L6	L7	L8	L9	L10	L11	L12	L13
VABM-L1-14HWS1	130	91	78.8	74.5	53.5	34.1	69.8	16	96.2	51.5	39.5	33	18	34	22	35.5
VABM-L1-14HWS2																21

Type	Size 14								
	H1	H2	H3	H4	H5	H6	H7	H8	H9
VABM-L1-14HWS1	66.8	16.5	33.8	42.6	26.9	24	22	45.5	24.8
VABM-L1-14HWS2									



## Data sheet – Manifold rail VABM

Number of valve positions	L1	L2	L3	L13
VABM-L1-10HWS1-G18-4-GR	116.2	84	31.5	16.1
VABM-L1-10HWS1-G18-8-GR	158.2	126	73.5	16.1
VABM-L1-10HWS2-G18-8-GR	184	168	73.5	8
VABM-L1-10HWS2-G18-12-GR	226	210	115.5	8
VABM-L1-10HWS2-G18-16-GR	268	252	157.5	8
VABM-L1-10HWS2-G18-24-GR	352	336	241.5	8
VABM-L1-10HWS2-H-G18-8-GR	184	168	73.5	8
VABM-L1-10HWS2-H-G18-8-GR	226	210	115.5	8
VABM-L1-10HWS2-H-G18-8-GR	268	252	157.5	8
VABM-L1-10HWS2-H-G18-8-GR	352	336	241.5	8
VABM-L1-14HWS1-G14-4-GR	135	64	48	35.5
VABM-L1-14HWS1-G14-8-GR	199	128	112	35.5
VABM-L1-14HWS2-G14-8-GR	234	192	112	21
VABM-L1-14HWS2-G14-12-GR	298	256	176	21
VABM-L1-14HWS2-G14-16-GR	362	320	240	21
VABM-L1-14HWS2-G14-24-GR	490	448	368	21
VABM-L1-14HWS2-H-G14-8-GR	234	192	112	21
VABM-L1-14HWS2-H-G14-12-GR	298	256	176	21
VABM-L1-14HWS2-H-G14-16-GR	362	320	240	21
VABM-L1-14HWS2-H-G14-24-GR	490	448	368	21

Valve terminal VTUG with multi-pin plug connection and fieldbus interface

Data sheet – Manifold rail VABM

**Dimensions – Recess for control cabinet installation, outlet orientation underneath, size 10**

Up to 8 valves

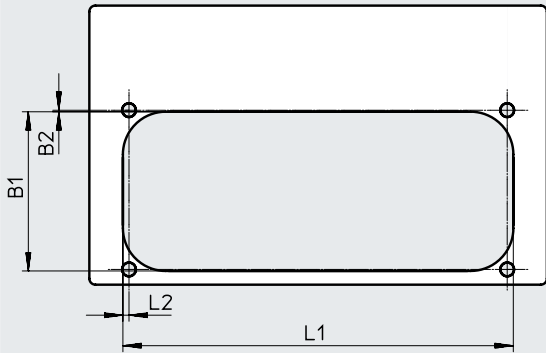

9 or more valves

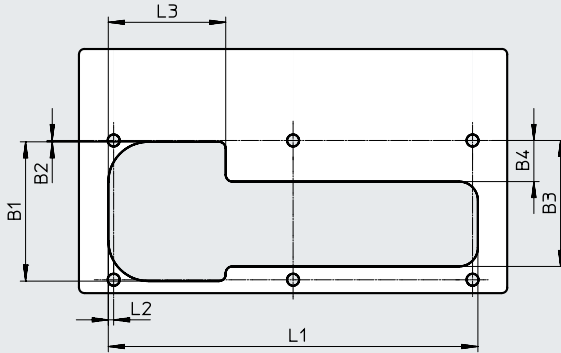

Type	B1	B2	L1	L2
VABM-L1-10...G18-4	52.7	0.5	86	2
VABM-L1-10...G18-5			96.5	
VABM-L1-10...G18-6			107	
VABM-L1-10...G18-7			117.5	
VABM-L1-10...G18-8			128	

Type	B1	B2	B3	B4	L1	L2	L3
VABM-L1-10...G18-9	52.7	0.5	47.2	15.4	138.5	2	44
VABM-L1-10...G18-10					149		
VABM-L1-10...G18-12					170		
VABM-L1-10...G18-16					212		
VABM-L1-10...G18-20					254		
VABM-L1-10...G18-24					296		

**Dimensions – Recess for control cabinet installation, outlet orientation underneath, size 14**

Up to 7 valves

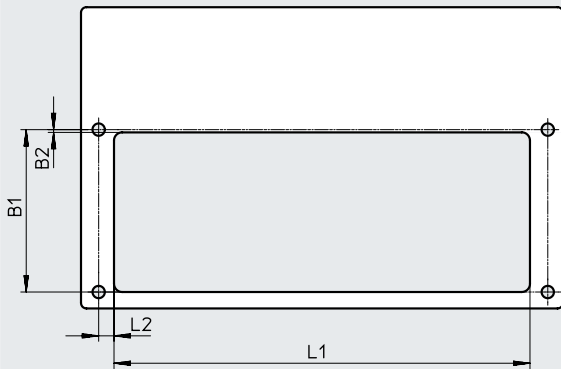

8 or more valves

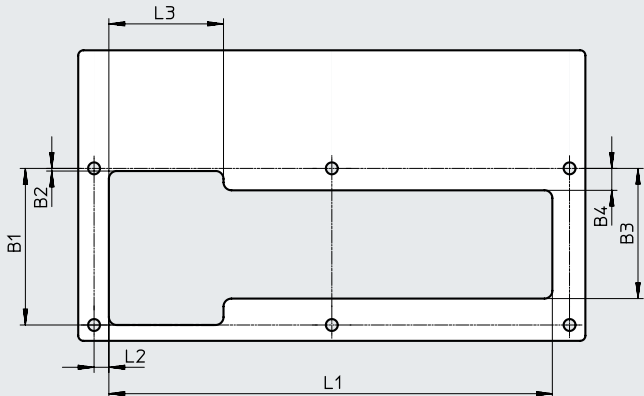

Type	B1	B2	L1	L2
VABM-L1-14...G14-4	59.3	1	103.9	5.6
VABM-L1-14...G14-5			119.9	
VABM-L1-14...G14-6			135.9	
VABM-L1-14...G14-7			151.9	

Type	B1	B2	B3	B4	L1	L2	L3
VABM-L1-14...G14-8	59.3	1	49.3	8.3	167.9	5.6	43.4
VABM-L1-14...G14-9					183.9		
VABM-L1-14...G14-10					199.9		
VABM-L1-14...G14-12					231.9		
VABM-L1-14...G14-16					295.9		
VABM-L1-14...G14-20					359.9		
VABM-L1-14...G14-24					423.9		

Data sheet – Manifold rail VABM

Dimensions – Recess for control cabinet installation, outlet orientation underneath, size 18

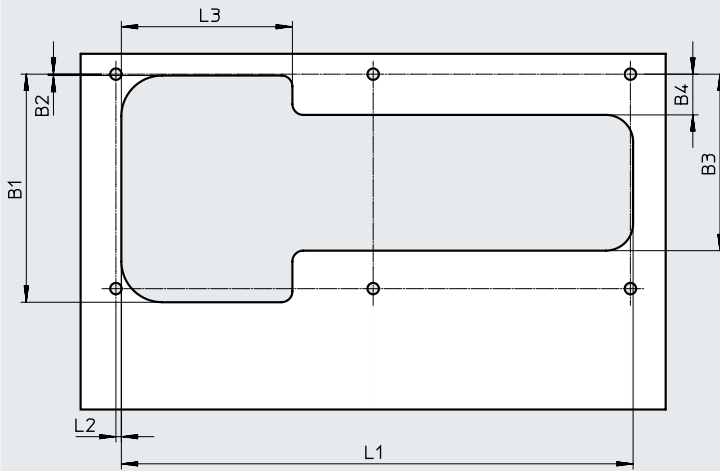

Type	B1	B2	B3	B4	L1	L2	L3
VABM-L1-18...G38-4	83.5	0.5	65	15	112.5	2	63
VABM-L1-18...G38-5					131.5		
VABM-L1-18...G38-6					150.5		
VABM-L1-18...G38-7					169.5		
VABM-L1-18...G38-8					188.5		
VABM-L1-18...G38-9					207.5		
VABM-L1-18...G38-10					226.5		
VABM-L1-18...G38-12					264.5		
VABM-L1-18...G38-16					340.5		
VABM-L1-18...G38-20					416.5		
VABM-L1-18...G38-24					492.5		

**Data sheet – Manifold rail VABM**

**Dimensions – Recess for control cabinet installation, outlet direction: front, size 10**

Single supply, up to 8 valves

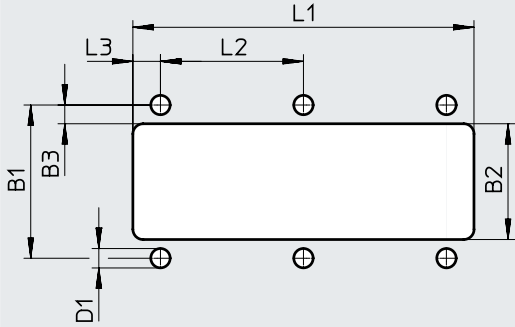

Type	B1	B2	B3	D1	L1	L2	L3
VABM-L1-10HWS1-G18-4-GR	45	34	5.5	5.7	100.2	42	8.1
VABM-L1-10HWS1-G18-8-GR					143.2		

Double supply, more than 8 valves

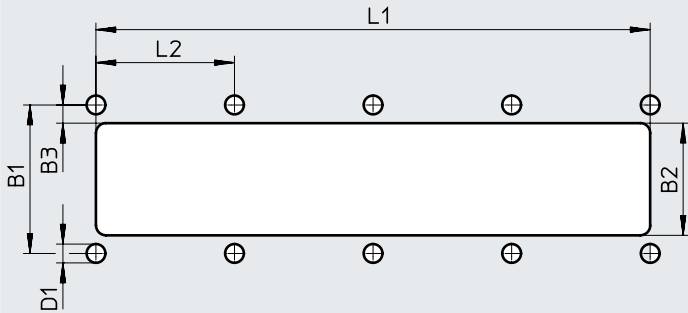

Type	B1	B2	B3	D1	L1	L2
VABM-L1-10HWS2-...G18-8-GR	45	34	5.5	5.7	168	42
VABM-L1-10HWS2-...G18-12-GR					210	
VABM-L1-10HWS2-...G18-16-GR					252	
VABM-L1-10HWS2-...G18-24-GR					336	

**Dimensions – Recess for control cabinet installation, outlet orientation: front, size 14**

Single supply, up to 8 valves

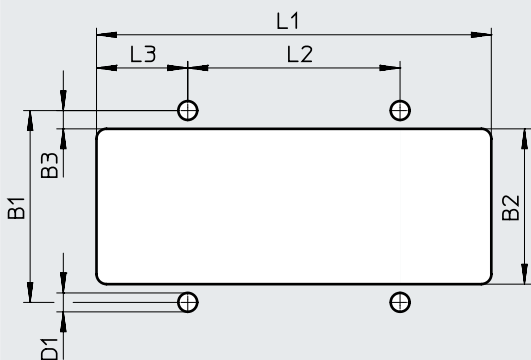

Type	B1	B2	B3	D1	L1	L2	L3
VABM-L1-14HWS1-G14-4-GR	57.8	46.8	5.5	5.7	119	64	27.5
VABM-L1-14HWS1-G14-8-GR					183		

Data sheet – Manifold rail VABM

Dimensions – Recess for control cabinet installation, outlet orientation: front, size 14

Double supply, more than 8 valves

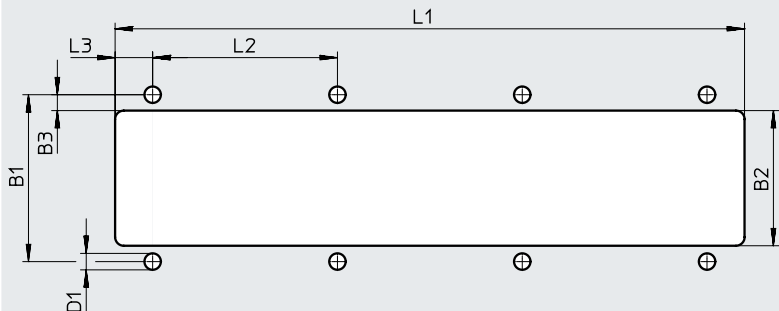

Type	B1	B2	B3	D1	L1	L2	L3
VABM-L1-14HWS2-G14-...-8-GR	57.8	46.8	5.5	5.7	218	64	13
VABM-L1-14HWS2-G14-...-12-GR					282		
VABM-L1-14HWS2-G14-...-16-GR					346		
VABM-L1-14HWS2-G14-...-24-GR					474		

Dimensions – Mounting holes for control cabinet installation, size 10

Download CAD data → [www.festo.com](http://www.festo.com)

Outlet orientation underneath

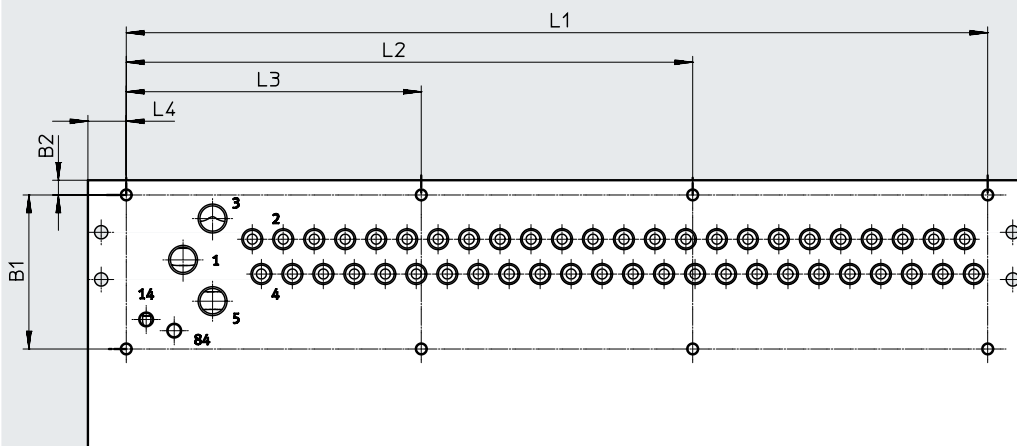

Type		Outlet orientation of electrical components on top						I-Port interface on the side
		B1	B2	L1	L2	L3	L4	L4
VABM-L1-10...-G18-4	Up to 8 valves	52.2	5	82	-	-	13	62.5
VABM-L1-10...-G18-5				92.5	-	-		
VABM-L1-10...-G18-6				103	-	-		
VABM-L1-10...-G18-7				113.5	-	-		
VABM-L1-10...-G18-8				124	-	-		
VABM-L1-10...-G18-9	Up to 20 valves	52.2	5	134.5	-	67.25	13	62.5
VABM-L1-10...-G18-10				145	-	72.5		
VABM-L1-10...-G18-12				166	-	83		
VABM-L1-10...-G18-16				208	-	104		
VABM-L1-10...-G18-20				250	-	125		
VABM-L1-10...-G18-24	24 valves	52.2	5	292	192	100	13	62.5

Data sheet – Manifold rail VABM

Dimensions – Mounting holes for control cabinet installation, size 10

Download CAD data → [www.festo.com](http://www.festo.com)

Outlet orientation: front

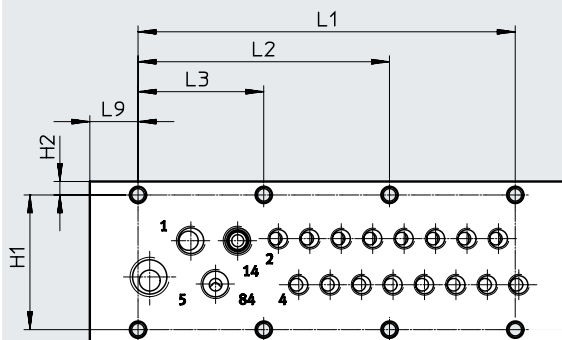

Type	H1	H2	L1	L2	L3	L9
VABM-L1-10HWS1-G18-4-GR	45	4.5	84	-	42	16.1
VABM-L1-10HWS1-G18-8-GR	45	4.5	126	84	42	16.1

Type	No. of valve positions	No. of mounting holes
VABM-L1-10HWS1-G18-4-GR	4	3
VABM-L1-10HWS1-G18-8-GR	8	4

Dimensions – Mounting holes for control cabinet installation, size 10

Download CAD data → [www.festo.com](http://www.festo.com)

Outlet orientation: front

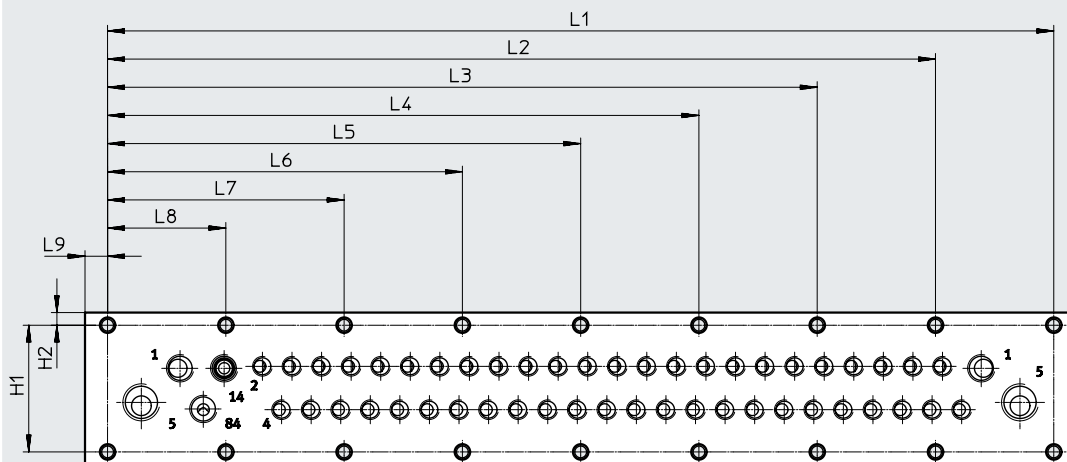

Type	H1	H2	L1	L2	L3	L4	L5	L6	L7	L8	L9
VABM-L1-10HWS2-...-8-GR	45	4.5	168	-	-	-	-	126	84	42	8
VABM-L1-10HWS2-...-12-GR	45	4.5	210	-	-	-	168	126	84	42	8
VABM-L1-10HWS2-...-16-GR	45	4.5	252	-	-	210	168	126	84	42	8
VABM-L1-10HWS2-...-24-GR	45	4.5	336	294	252	210	168	126	84	42	8

Type	No. of valve positions	No. of mounting holes
VABM-L1-10HWS2-...-8-GR	8	5
VABM-L1-10HWS2-...-12-GR	12	6
VABM-L1-10HWS2-...-16-GR	16	7
VABM-L1-10HWS2-...-24-GR	24	9

Data sheet – Manifold rail VABM

**Dimensions – Mounting holes for control cabinet installation, size 14**

Download CAD data → [www.festo.com](http://www.festo.com)

Outlet orientation underneath

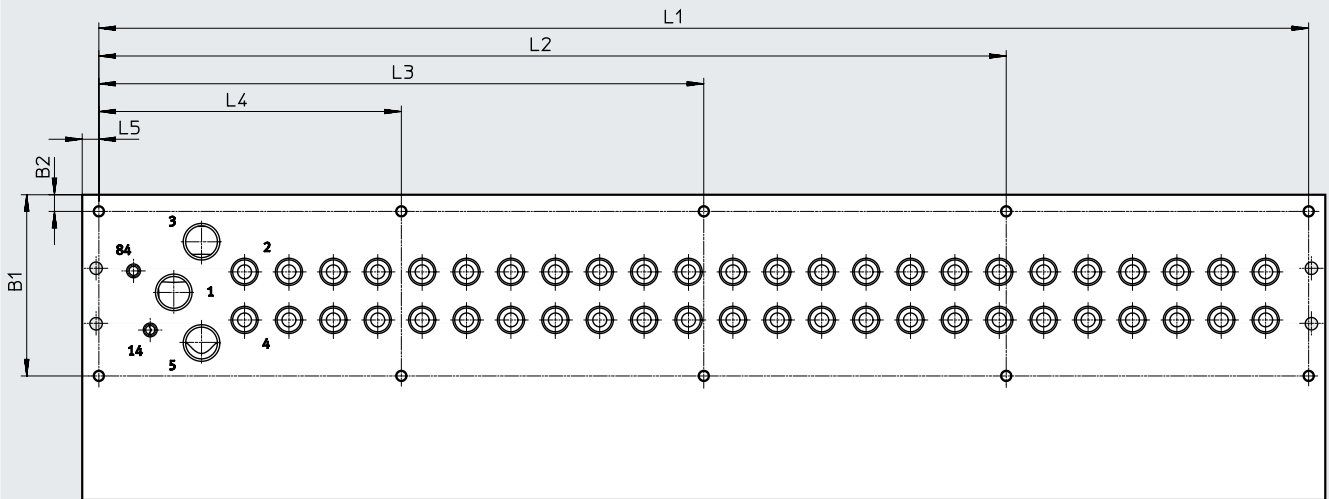

Type		Outlet orientation of electrical components on top							I-Port interface on the side
		B1	B2	L1	L2	L3	L4	L5	L4
VABM-L1-14...-G14-4	Up to 8 valves	59.3	6	116	-	-	-	6	55.5
VABM-L1-14...-G14-5				132	-	-	-		
VABM-L1-14...-G14-6				148	-	-	-		
VABM-L1-14...-G14-7				164	-	-	-		
VABM-L1-14...-G14-8	8 to 10 valves	59.3	6	180	-	-	90	6	55.5
VABM-L1-14...-G14-9				196	-	-	98		
VABM-L1-14...-G14-10				212	-	-	106		
VABM-L1-14...-G14-12	12 valves and 16 valves	59.3	6	244	-	162	82	6	55.5
VABM-L1-14...-G14-16				308	-	204	104		
VABM-L1-14...-G14-20	20 valves and 24 valves	59.3	6	372	279	186	93	6	55.5
VABM-L1-14...-G14-24				436	327	218	109		

Data sheet – Manifold rail VABM

**Dimensions – Mounting holes for control cabinet installation, size 14**

Download CAD data → [www.festo.com](http://www.festo.com)

Outlet orientation: front

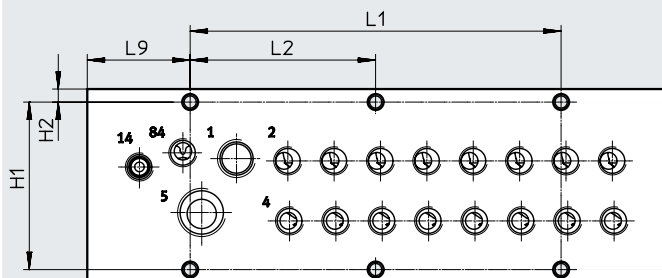

Type	H1	H2	L1	L2	L9
VABM-L1-14HWS1-G14-4-GR	57.8	4.5	64	–	35.5
VABM-L1-14HWS1-G14-8-GR	57.8	4.5	128	64	35.5

Type	No. of valve positions	No. of mounting holes
VABM-L1-14HWS1-G14-4-GR	4	2
VABM-L1-14HWS1-G14-8-GR	8	3

**Dimensions – Mounting holes for control cabinet installation, size 14**

Download CAD data → [www.festo.com](http://www.festo.com)

Outlet orientation: front

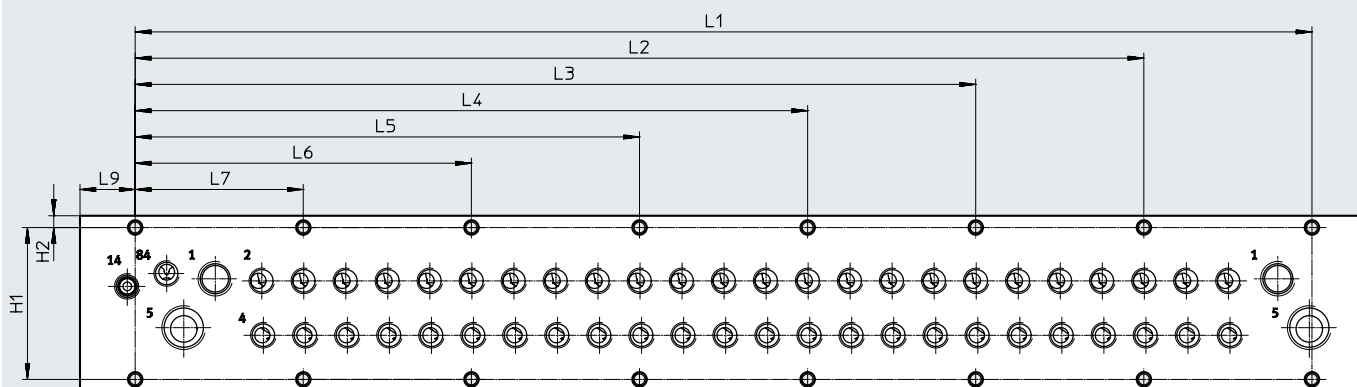

Type	H1	H2	L1	L2	L3	L4	L5	L6	L7	L9
VABM-L1-14HWS2-...-8-GR	57.8	4.5	192	–	–	–	–	128	64	21
VABM-L1-14HWS2-...-12-GR	57.8	4.5	256	–	–	–	192	128	64	21
VABM-L1-14HWS2-...-16-GR	57.8	4.5	320	–	–	256	192	128	64	21
VABM-L1-14HWS2-...-24-GR	57.8	4.5	448	384	320	256	192	128	64	21

Type	No. of valve positions	No. of mounting holes
VABM-L1-14HWS2-...-8-GR	8	4
VABM-L1-14HWS2-...-12-GR	12	5
VABM-L1-14HWS2-...-16-GR	16	6
VABM-L1-14HWS2-...-24-GR	24	8



Data sheet – Manifold rail VABM

**Dimensions – Mounting holes for control cabinet installation, size 18**

Download CAD data → [www.festo.com](http://www.festo.com)

Outlet orientation underneath

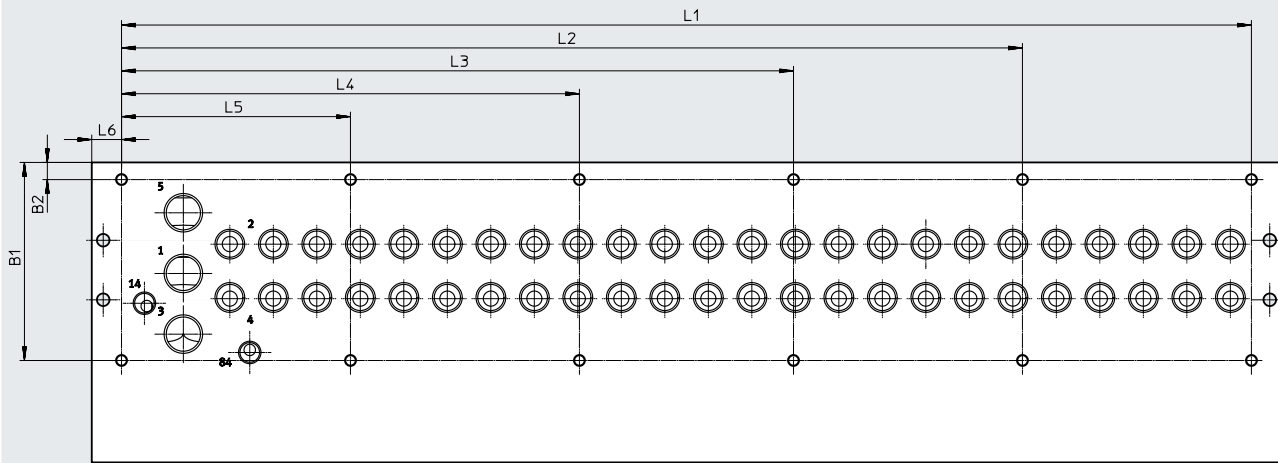

Type		Outlet orientation of electrical components						I-Port interface on the side	
		B1	B2	L1	L2	L3	L4	L5	L4
VABM-L1-18...-G38-4	4 valves and 5 valves	86.5	7.5	113.5	-	-	-	-	54.5
VABM-L1-18...-G38-5				132.5	-	-	-	-	
VABM-L1-18...-G38-6	6 to 10 valves	86.5	7.5	151.5	-	-	-	75.8	54.5
VABM-L1-18...-G38-7				170.5	-	-	-	85.3	
VABM-L1-18...-G38-8				189.5	-	-	-	94.8	
VABM-L1-18...-G38-9				208.5	-	-	-	104.3	
VABM-L1-18...-G38-10				227.5	-	-	-	113.8	
VABM-L1-18...-G38-12	12 valves	86.5	7.5	265.5	-	-	165.5	100	54.5
VABM-L1-18...-G38-16	16 to 20 valves	86.5	7.5	341.5	-	-	170.8	100	54.5
VABM-L1-18...-G38-20				417.5	-	317.5	208.8	100	
VABM-L1-18...-G38-24	24 valves	86.5	7.5	493.5	393.5	293.5	200	100	54.5

Valve terminal VTUG with multi-pin plug connection and fieldbus interface

Ordering data

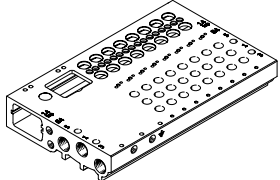
Ordering data	Description	Part no.	Type	
<b>Manifold rail for semi in-line valve</b>				
	<b>Size 10 mm</b>			
	Connections 2, 4 on the valve	4 valve positions	573423	VABM-L1-10G-G18-4-GR
		5 valve positions	573424	VABM-L1-10G-G18-5-GR
		6 valve positions	573425	VABM-L1-10G-G18-6-GR
		7 valve positions	573426	VABM-L1-10G-G18-7-GR
		8 valve positions	573427	VABM-L1-10G-G18-8-GR
		9 valve positions	573428	VABM-L1-10G-G18-9-GR
		10 valve positions	573429	VABM-L1-10G-G18-10-GR
		12 valve positions	573430	VABM-L1-10G-G18-12-GR
		16 valve positions	573431	VABM-L1-10G-G18-16-GR
		20 valve positions	573432	VABM-L1-10G-G18-20-GR
		24 valve positions	573433	VABM-L1-10G-G18-24-GR
		8 double solenoid + 8 single solenoid valves	573927	VABM-L1-10G-G18-16-M-GR
		4 double solenoid + 16 single solenoid valves	573928	VABM-L1-10G-G18-20-M-GR
		24 single solenoid valves	573929	VABM-L1-10G-G18-24-M-GR
	<b>Size 14 mm</b>			
	Port 2, 4 on the valve	4 valve positions	573489	VABM-L1-14G-G14-4-GR
		5 valve positions	573490	VABM-L1-14G-G14-5-GR
		6 valve positions	573491	VABM-L1-14G-G14-6-GR
		7 valve positions	573492	VABM-L1-14G-G14-7-GR
		8 valve positions	573493	VABM-L1-14G-G14-8-GR
		9 valve positions	573494	VABM-L1-14G-G14-9-GR
		10 valve positions	573495	VABM-L1-14G-G14-10-GR
		12 valve positions	573496	VABM-L1-14G-G14-12-GR
		16 valve positions	573497	VABM-L1-14G-G14-16-GR
		20 valve positions	573498	VABM-L1-14G-G14-20-GR
		24 valve positions	573499	VABM-L1-14G-G14-24-GR
		8 double solenoid + 8 single solenoid valves	573933	VABM-L1-14G-G14-16-M-GR
		4 double solenoid + 16 single solenoid valves	573934	VABM-L1-14G-G14-20-M-GR
		24 single solenoid valves	573935	VABM-L1-14G-G14-24-M-GR
	<b>Size 18 mm</b>			
	Port 2, 4 on the valve	4 valve positions	8004899	VABM-L1-18G-G38-4-G
		5 valve positions	8004900	VABM-L1-18G-G38-5-G
		6 valve positions	8004901	VABM-L1-18G-G38-6-G
		7 valve positions	8004902	VABM-L1-18G-G38-7-G
8 valve positions		8004903	VABM-L1-18G-G38-8-G	
9 valve positions		8004904	VABM-L1-18G-G38-9-G	
10 valve positions		8004905	VABM-L1-18G-G38-10-G	
12 valve positions		8004906	VABM-L1-18G-G38-12-G	
16 valve positions		8004907	VABM-L1-18G-G38-16-G	
20 valve positions		8004908	VABM-L1-18G-G38-20-G	
24 valve positions		8004909	VABM-L1-18G-G38-24-G	
8 double solenoid + 8 single solenoid valves		8004910	VABM-L1-18G-G38-16-M-G	
4 double solenoid + 16 single solenoid valves		8004911	VABM-L1-18G-G38-20-M-G	
24 single solenoid valves		8004912	VABM-L1-18G-G38-24-M-G	

Ordering data

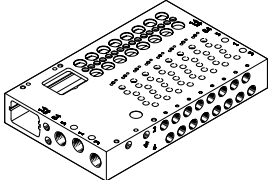
Ordering data	Description	Part no.	Type	
<b>Manifold rail for sub-base valve</b>				
	<b>Size 10 mm</b>			
	Port 2, 4 at front	4 valve positions	573434	VABM-L1-10HW-G18-4-GR
		5 valve positions	573435	VABM-L1-10HW-G18-5-GR
		6 valve positions	573436	VABM-L1-10HW-G18-6-GR
		7 valve positions	573437	VABM-L1-10HW-G18-7-GR
		8 valve positions	573438	VABM-L1-10HW-G18-8-GR
		9 valve positions	573439	VABM-L1-10HW-G18-9-GR
		10 valve positions	573440	VABM-L1-10HW-G18-10-GR
		12 valve positions	573441	VABM-L1-10HW-G18-12-GR
		16 valve positions	573442	VABM-L1-10HW-G18-16-GR
		20 valve positions	573443	VABM-L1-10HW-G18-20-GR
		24 valve positions	573444	VABM-L1-10HW-G18-24-GR
		8 double solenoid + 8 single solenoid valves	573930	VABM-L1-10HW-G18-16-M-GR
		4 double solenoid + 16 single solenoid valves	573931	VABM-L1-10HW-G18-20-M-GR
	24 single solenoid valves	573932	VABM-L1-10HW-G18-24-M-GR	
	<b>Size 14 mm</b>			
	Port 2, 4 at front	4 valve positions	573500	VABM-L1-14W-G14-4-GR
		5 valve positions	573501	VABM-L1-14W-G14-5-GR
		6 valve positions	573502	VABM-L1-14W-G14-6-GR
		7 valve positions	573503	VABM-L1-14W-G14-7-GR
		8 valve positions	573504	VABM-L1-14W-G14-8-GR
		9 valve positions	573505	VABM-L1-14W-G14-9-GR
		10 valve positions	573506	VABM-L1-14W-G14-10-GR
		12 valve positions	573507	VABM-L1-14W-G14-12-GR
		16 valve positions	573508	VABM-L1-14W-G14-16-GR
		20 valve positions	573509	VABM-L1-14W-G14-20-GR
		24 valve positions	573510	VABM-L1-14W-G14-24-GR
		8 double solenoid + 8 single solenoid valves	573936	VABM-L1-14W-G14-16-M-GR
		4 double solenoid + 16 single solenoid valves	573937	VABM-L1-14W-G14-20-M-GR
	24 single solenoid valves	573938	VABM-L1-14W-G14-24-M-GR	
	<b>Size 18 mm</b>			
	Port 2, 4 at front	4 valve positions	8004913	VABM-L1-18W-G38-4-G
		5 valve positions	8004914	VABM-L1-18W-G38-5-G
		6 valve positions	8004915	VABM-L1-18W-G38-6-G
		7 valve positions	8004916	VABM-L1-18W-G38-7-G
		8 valve positions	8004917	VABM-L1-18W-G38-8-G
9 valve positions		8004918	VABM-L1-18W-G38-9-G	
10 valve positions		8004919	VABM-L1-18W-G38-10-G	
12 valve positions		8004920	VABM-L1-18W-G38-12-G	
16 valve positions		8004921	VABM-L1-18W-G38-16-G	
20 valve positions		8004922	VABM-L1-18W-G38-20-G	
24 valve positions		8004923	VABM-L1-18W-G38-24-G	
8 double solenoid + 8 single solenoid valves		8004924	VABM-L1-18W-G38-16-M-G	
4 double solenoid + 16 single solenoid valves		8004925	VABM-L1-18W-G38-20-M-G	
24 single solenoid valves	8004926	VABM-L1-18W-G38-24-M-G		

Valve terminal VTUG with multi-pin plug connection and fieldbus interface

Ordering data

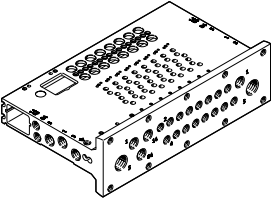
Ordering data	Description	Part no.	Type	
<b>Manifold rail for sub-base valve, for control cabinet installation, outlet orientation: front</b>				
	<b>Size 10 mm</b>			
	Port 2, 4 at the front, single supply	4 valve positions	8058335	VABM-L1-10HWS1-G18-4-GR
		8 valve positions	8058336	VABM-L1-10HWS1-G18-8-GR
	Port 2, 4 at the front, double supply	8 valve positions	8058338	VABM-L1-10HWS2-G18-8-GR
		12 valve positions	8058339	VABM-L1-10HWS2-G18-12-GR
		16 valve positions	8058340	VABM-L1-10HWS2-G18-16-GR
		24 valve positions	8058341	VABM-L1-10HWS2-G18-24-GR
	<b>Size 14 mm</b>			
	Port 2, 4 at the front, single supply	4 valve positions	8058342	VABM-L1-14HWS1-G14-4-GR
		8 valve positions	8058343	VABM-L1-14HWS1-G14-8-GR
	Port 2, 4 at the front, double supply	8 valve positions	8058344	VABM-L1-14HWS2-G14-8-GR
		12 valve positions	8058345	VABM-L1-14HWS2-G14-12-GR
		16 valve positions	8058346	VABM-L1-14HWS2-G14-16-GR
		24 valve positions	8058347	VABM-L1-14HWS2-G14-24-GR

## Data sheet – Multi-pin plug connection

The following multi-pin plug connections are available for the valve terminal VTUG:

- Sub-D (25-pin)
- Sub-D (44-pin)
- Ribbon cable (26-pin)
- Ribbon cable (50-pin)



### Electric multi-pin

Each pin on the multi-pin plug can actuate exactly one solenoid coil.

If the maximum configurable number of valve positions is 24, this means that 48 valve functions can be addressed.

The valves can be switched using positive or negative logic (positive switching or negative switching).

Mixed operation is generally not possible; however, an exception is made for the V22 ... V25 variants with 25-pin Sub-D. With these variants, a specific range of valve positions (e.g. Com 16...19) is supplied with common voltage.

This allows these ranges to be switched with positive or negative logic and valve groups to be switched off independently of the other ranges. Mixed operation within a range is not permitted.

#### Note

A double solenoid valve occupies one valve position and two pins on the multi-pin plug. This means that the number of double solenoid valves per manifold rail is limited. (Pin allocation → page 182)

General technical data				
Type	VAEM-L1-S-M1-25	VAEM-L1-S-M1-44	VAEM-L1-S-M3-26	VAEM-L1-S-M3-50
Number of pins	25-pin	44-pin	26-pin	50-pin
Electrical connection	Sub-D plug		Ribbon connector	
Max. no. of valve positions	24		24	
Degree of protection to EN 60529	IP67		IP40	
Material	PA		PA	
Note on materials	RoHS-compliant		RoHS-compliant	
Certification	c UL us – Recognized (OL) c CSA us (OL)			
CE marking (see declaration of conformity) <sup>1)</sup>	To EU EMC Directive			
Corrosion resistance class CRC <sup>2)</sup>	2			
Weight [g]	53		45	48

1) For information about the area of use, see the EC declaration of conformity at: [www.festo.com/sp](http://www.festo.com/sp) → Certificates.

If the devices are subject to usage restrictions in residential, commercial or light-industrial environments, further measures for the reduction of the emitted interference may be necessary.

2) Corrosion resistance class CRC 2 to Festo standard FN 940070

Moderate corrosion stress. Indoor applications in which condensation can occur. External visible parts with primarily decorative surface requirements which are in direct contact with a normal industrial environment.

Valve terminal VTUG with multi-pin plug connection

Data sheet – Multi-pin plug connection

Pin allocation – Sub-D plug, 25-pin												
	Pin	Wire colour <sup>1)</sup>	M1-25 (V20)								M1-25V1 (V22)	
			12x double solenoid		8x double solenoid 8x single solenoid		4x double solenoid 16x single solenoid		24x single solenoid			
	1	WH	VP0	14	VP0	14	VP0	14	VP0	14	VP0	14
	2	BN	VP0	12	VP0	12	VP0	12	VP23	14	VP0	12
	3	GN	VP1	14	VP1	14	VP1	14	VP1	14	VP1	14
	4	YE	VP1	12	VP1	12	VP1	12	VP22	14	VP1	12
	5	GY	VP2	14	VP2	14	VP2	14	VP2	14	VP2	14
	6	PK	VP2	12	VP2	12	VP2	12	VP21	14	VP2	12
	7	BU	VP3	14	VP3	14	VP3	14	VP3	14	VP3	14
	8	RD	VP3	12	VP3	12	VP3	12	VP20	14	VP3	12
	9	BK	VP4	14	VP4	14	VP4	14	VP4	14	VP4	14
	10	VT	VP4	12	VP4	12	VP19	14	VP19	14	VP4	12
	11	GY PK	VP5	14	VP5	14	VP5	14	VP5	14	VP5	14
	12	RD BU	VP5	12	VP5	12	VP18	14	VP18	14	VP5	12
	13	GN WH	VP6	14	VP6	14	VP6	14	VP6	14	VP6	14
	14	BN GN	VP6	12	VP6	12	VP17	14	VP17	14	VP6	12
	15	YE WH	VP7	14	VP7	14	VP7	14	VP7	14	VP7	14
	16	BN YE	VP7	12	VP7	12	VP16	14	VP16	14	VP7	12
	17	GY WH	VP8	14	VP8	14	VP8	14	VP8	14	VP8	14
	18	BN GY	VP8	12	VP15	14	VP15	14	VP15	14	VP8	12
	19	WH PK	VP9	14	VP9	14	VP9	14	VP9	14	VP9	14
	20	BN PK	VP9	12	VP14	14	VP14	14	VP14	14	VP9	12
	21	BU WH	VP10	14	VP10	14	VP10	14	VP10	14	Com 16 ...19	
	22	BN BU	VP10	12	VP13	14	VP13	14	VP13	14	Com 12...15	
	23	RD WH	VP11	14	VP11	14	VP11	14	VP11	14	Com 8 ...11	
	24	BN RD	VP11	12	VP12	14	VP12	14	VP12	14	Com 4 ...7	
	25	BK WH	Com		Com		Com	Com	Com		Com 0 ...3	

1) To IEC 60757  
VP Valve position

 - **Note**  
A grey field means that a double solenoid valve can be used. Only single solenoid valves can be used for fields with a white background.

Data sheet – Multi-pin plug connection

Pin allocation – Sub-D plug, 25-pin					Pin allocation – Sub-D plug, 44-pin				
Pin	Wire colour <sup>1)</sup>	M1-25V2 (V23)	M1-25V3 (V24)	M1-25V4 (V25)	Pin	Wire colour <sup>1)</sup>	M1-44 (V21) 18x double solenoid, 6x single solenoid		
14+ + 1	1 WH	VP0 14	VP0 14	VP0 14	1 WH	VP0 14			
15+ + 2	2 BN	VP0 12	VP0 12	VP1 14	2 BN	VP0 12			
16+ + 3	3 GN	VP1 14	VP1 14	VP2 14	3 GN	VP1 14			
17+ + 4	4 YE	VP1 12	VP1 12	VP3 14	4 YE	VP1 12			
18+ + 5	5 GY	VP2 14	VP2 14	VP4 14	5 GY	VP2 14			
19+ + 6	6 PK	VP2 12	VP2 12	VP5 14	6 PK	VP2 12			
20+ + 7	7 BU	VP3 14	VP3 14	VP6 14	7 BU	VP3 14			
21+ + 8	8 RD	VP3 12	VP3 12	VP7 14	8 RD	VP3 12			
22+ + 9	9 BK	VP4 14	VP4 14	VP8 14	9 BK	VP4 14			
23+ + 10	10 VT	VP4 12	VP5 14	VP9 14	10 VT	VP4 12			
24+ + 11	11 GY PK	VP5 14	VP6 14	VP10 14	11 GY PK	VP5 14			
25+ + 12	12 RD BU	VP5 12	VP7 14	VP11 14	12 RD BU	VP5 12			
	13 GN WH	VP6 14	VP8 14	VP12 14	13 GN WH	VP6 14			
	14 BN GN	VP6 12	VP9 14	VP13 14	14 BN GN	VP6 12			
	15 YE WH	VP7 14	VP10 14	VP14 14	15 YE WH	VP7 14			
	16 BN YE	VP7 12	VP11 14	VP15 14	16 BN YE	VP7 12			
	17 GY WH	VP8 14	VP12 14	VP16 14	17 GY WH	VP8 14			
	18 BN GY	VP9 14	VP13 14	VP17 14	18 BN GY	VP8 12			
	19 WH PK	VP10 14	VP14 14	VP18 14	19 WH PK	VP9 14			
	20 BN PK	VP11 14	VP15 14	VP19 14	20 BN PK	VP9 12			
	21 BU WH	Com 16 ...19	Com 16 ...19	Com 16 ...19	21 BU WH	VP10 14			
	22 BN BU	Com 12...15	Com 12...15	Com 12...15	22 BN BU	VP10 12			
	23 RD WH	Com 8 ...11	Com 8 ...11	Com 8 ...11	23 RD WH	VP11 14			
	24 BN RD	Com 4 ...7	Com 4 ...7	Com 4 ...7	24 BN RD	VP11 12			
	25 BK WH	Com 0 ...3	Com 0 ...3	Com 0 ...3	25 BK WH	VP12 14			
	-				26 BK BN	VP12 12			
	-				27 GN GY	VP13 14			
	-				28 YE GY	VP13 12			
	-				29 GN PK	VP14 14			
	-				30 YE PK	VP14 12			
	-				31 GN BU	VP15 14			
	-				32 YE BU	VP15 12			
	-				33 RD GN	VP16 14			
	-				34 RD YE	VP16 12			
	-				35 BK GN	VP17 14			
	-				36 BK YE	VP17 12			
	-				37 BU GY	VP18 14			
	-				38 BU PK	VP19 14			
	-				39 RD GY	VP20 14			
	-				40 RD PK	VP21 14			
	-				41 BK GY	VP22 14			
	-				42 BK PK	VP23 14			
	-				43 BK BU	com			
	-				44 BK RD				

1) To IEC 60757  
VP Valve position

 **Note**  
A grey field means that a double solenoid valve can be used. Only single solenoid valves can be used for fields with a white background.

Valve terminal VTUG with multi-pin plug connection

Data sheet – Multi-pin plug connection

Pin allocation – Ribbon cable, 26-pin										Pin allocation – Ribbon cable, 50-pin			
Pin	M3-26 (V20)				Pin	M3-50 (V26)							
	12x double solenoid	8x double solenoid 8x single solenoid	4x double solenoid 16x single solenoid	24x single solenoid		Pin	M3-50 (V26)						
1	VP0	14	VP0	14	VP0	14	VP0	14	1	VP0	14		
2	VP0	12	VP0	12	VP0	12	VP23	14	2	VP0	12		
3	VP1	14	VP1	14	VP1	14	VP1	14	3	VP1	14		
4	VP1	12	VP1	12	VP1	12	VP22	14	4	VP1	12		
5	VP2	14	VP2	14	VP2	14	VP2	14	5	VP2	14		
6	VP2	12	VP2	12	VP2	12	VP21	14	6	VP2	12		
7	VP3	14	VP3	14	VP3	14	VP3	14	7	VP3	14		
8	VP3	12	VP3	12	VP3	12	VP20	14	8	VP3	12		
9	VP4	14	VP4	14	VP4	14	VP4	14	9	VP4	14		
10	VP4	12	VP4	12	VP19	14	VP19	14	10	VP4	12		
11	VP5	14	VP5	14	VP5	14	VP5	14	11	VP5	14		
12	VP5	12	VP5	12	VP18	14	VP18	14	12	VP5	12		
13	VP6	14	VP6	14	VP6	14	VP6	14	13	VP6	14		
14	VP6	12	VP6	12	VP17	14	VP17	14	14	VP6	12		
15	VP7	14	VP7	14	VP7	14	VP7	14	15	VP7	14		
16	VP7	12	VP7	12	VP16	14	VP16	14	16	VP7	12		
17	VP8	14	VP8	14	VP8	14	VP8	14	17	VP8	14		
18	VP8	12	VP15	14	VP15	14	VP15	14	18	VP8	12		
19	VP9	14	VP9	14	VP9	14	VP9	14	19	VP9	14		
20	VP9	12	VP14	14	VP14	14	VP14	14	20	VP9	12		
21	VP10	14	VP10	14	VP10	14	VP10	14	21	VP10	14		
22	VP10	12	VP13	14	VP13	14	VP13	14	22	VP10	12		
23	VP11	14	VP11	14	VP11	14	VP11	14	23	VP11	14		
24	VP11	12	VP12	14	VP12	14	VP12	14	24	VP11	12		
25	Com		Com		Com	Com	Com		25	VP12	14		
26	Com		Com		Com		Com		26	VP12	12		
-									27	VP13	14		
-									28	VP13	12		
-									29	VP14	14		
-									30	VP14	12		
-									31	VP15	14		
-									32	VP15	12		
-									33	VP16	14		
-									34	VP16	12		
-									35	VP17	14		
-									36	VP17	12		
-									37	VP18	14		
-									38	VP18	12		
-									39	VP19	14		
-									40	VP19	12		
-									41	VP20	14		
-									42	VP20	12		
-									43	VP21	14		
-									44	VP21	12		
-									45	VP22	14		
-									46	VP22	12		
-									47	VP23	14		
-									48	VP23	12		
-									49	Com			
-									50				

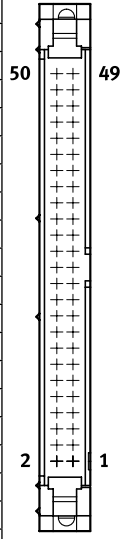
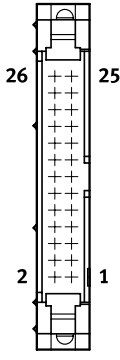

**Note**  
 A grey field means that a double solenoid valve can be used.  
 Only single solenoid valves can be used for fields with a white background.

VP Valve position



Data sheet – Multi-pin plug connection

**Dimensions**

Download CAD data → [www.festo.com](http://www.festo.com)

Multi-pin plug connection, Sub-D

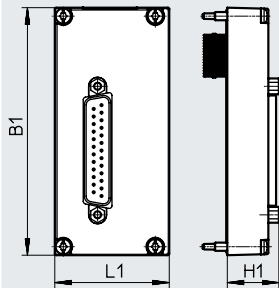

-  - **Note**

Dimensions of the manifold rail with electrical connection  
(→ page 157)

Type	B1	L1	H1
VAEM-L1-S-M1-...	90.5	41.9	18.9

**Dimensions**

Download CAD data → [www.festo.com](http://www.festo.com)

Multi-pin plug connection, ribbon cable

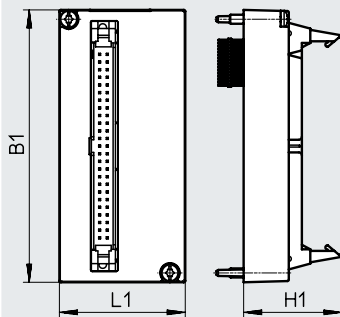

-  - **Note**

Dimensions of the manifold rail with electrical connection  
(→ page 157)

Type	B1	L1	H1
VAEM-L1-S-M3-...	90.5	41.9	32.7

Valve terminal VTUG with multi-pin plug connection

Accessories – Multi-pin plug connection

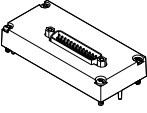
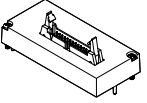
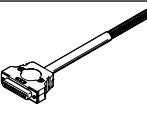
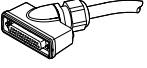
Ordering data		Description	Part no.	Type	
<b>Electrical interface, Sub-D</b>					
	25-pin	For variant M1-25 (V20)	573445	VAEM-L1-S-M1-25	
		For variant M1-25V1 (V22)	573447	VAEM-L1-S-M1-25V1	
		For variant M1-25V2 (V23)	573448	VAEM-L1-S-M1-25V2	
		For variant M1-25V3 (V24)	573449	VAEM-L1-S-M1-25V3	
		For variant M1-25V4 (V25)	573450	VAEM-L1-S-M1-25V4	
	44-pin	For variant M1-44 (V21)	573446	VAEM-L1-S-M1-44	
<b>Electrical interface, ribbon connector</b>					
	26-pin	For variant M3-26 (V20)	573452	VAEM-L1-S-M3-26	
	50-pin	For variant M3-50 (V26)	573451	VAEM-L1-S-M3-50	
<b>Connecting cable for multi-pin plug</b>					
	Sub-D socket, straight	<ul style="list-style-type: none"> <li>• 25-pin, up to 24 coils, IP40</li> <li>• Open cable end, 25-wire</li> </ul>	2.5 m	575417	NEBV-S1G25-K-2.5-N-LE25-S6
			5 m	575418	NEBV-S1G25-K-5-N-LE25-S6
			10 m	575419	NEBV-S1G25-K-10-N-LE25-S6
		<ul style="list-style-type: none"> <li>• 44-pin, up to 42 coils, IP40</li> <li>• Open cable end, 44-wire</li> </ul>	2.5 m	575113	NEBV-S1G44-K-2.5-N-LE44-S6
			5 m	575114	NEBV-S1G44-K-5-N-LE44-S6
			10 m	575115	NEBV-S1G44-K-10-N-LE44-S6
	Sub-D socket, angled	<ul style="list-style-type: none"> <li>• 25-pin, up to 24 coils, IP65</li> <li>• Open cable end, 25-wire</li> </ul>	2.5 m	575423	NEBV-S1WA25-K-2.5-N-LE25-S9
			5 m	575424	NEBV-S1WA25-K-5-N-LE25-S9
			10 m	575425	NEBV-S1WA25-K-10-N-LE25-S9
		<ul style="list-style-type: none"> <li>• 44-pin, up to 42 coils, IP65</li> <li>• Open cable end, 44-wire</li> </ul>	2.5 m	575420	NEBV-S1WA44-K-2.5-N-LE44-S9
			5 m	575421	NEBV-S1WA44-K-5-N-LE44-S9
			10 m	575422	NEBV-S1WA44-K-10-N-LE44-S9

## Data sheet – I-Port interface/IO-Link

Festo-specific, standardised interface for direct connection to the fieldbus by mounting the bus node CTEU or to an IO-Link master via a cable (in IO-Link mode).



### I-Port interface/IO-Link

Versions:

- As I-Port interface for bus node (CTEU)
- IO-Link mode for direct connection to a higher-level IO-Link master

The following protocols are supported in connection with the associated CTEU bus node:

- CANopen
- DeviceNet
- PROFIBUS
- CC-Link
- EtherCAT

The electrical supply/transmission of communication data takes place via an M12 plug.

The valve terminal can be equipped with 4 to 24 (double solenoid) valves.

General technical data			
Types of communication		IO-Link	
Electrical connection		<ul style="list-style-type: none"> <li>• M12 plug, 5-pin</li> <li>• A-coded</li> <li>• Metal thread for shielding</li> </ul>	
Baud rate	COM3	[kbps]	230.4
	COM2	[kbps]	38.4
Intrinsic current consumption, logic supply PS		[mA]	30
Intrinsic current consumption, valve supply PL		[mA]	30
Max. number of solenoid coils	VAEM-L1-S-8-PT		16
	VAEM-L1-S-16-PT		32
	VAEM-L1-S-24-PT		48
Max. no. of valve positions	VAEM-L1-S-8-PT		8
	VAEM-L1-S-16-PT		16
	VAEM-L1-S-24-PT		24
Ambient temperature		[°C]	-5 ... +50
Product weight	Outlet on top	[g]	49
	Outlet on the side	[g]	100
Degree of protection to EN 60529		IP67	
Certification		c UL us – Recognized (OL) c CSA us (OL)	
CE marking (see declaration of conformity) <sup>1)</sup>		To EU EMC Directive	
Corrosion resistance class CRC <sup>2)</sup>		2	

1) For information about the area of use, see the EC declaration of conformity at: [www.festo.com/sp](http://www.festo.com/sp) → Certificates.

If the devices are subject to usage restrictions in residential, commercial or light-industrial environments, further measures for the reduction of the emitted interference may be necessary.

2) Corrosion resistance class CRC 2 to Festo standard FN 940070

Moderate corrosion stress. Indoor applications in which condensation can occur. External visible parts with primarily decorative surface requirements which are in direct contact with a normal industrial environment.

Valve terminal VTUG, I-Port interface/IO-Link

Data sheet – I-Port interface/IO-Link

LED display	Colour	Status	Function
Status LED X1	Red/ green	Off	No 24 V logic
		Static green	Everything OK
		Flashing green	Communication error (in the I-Port or IO-Link protocol)
		Flashing red/green	Load supply error (undervoltage or no load supply)
		Static red	Load supply error and communication error

Pin allocation – I-Port interface/IO-Link			
	Pin	Allocation	Description
	1	24V <sub>EL/SEN</sub>	Operating voltage supply (electronics, sensors/inputs)
	2	24V <sub>VAL/OUT</sub>	Load voltage supply (valves/outputs)
	3	0V <sub>EL/SEN</sub>	Operating voltage supply (electronics, sensors/inputs)
	4	C/Q	Data communication
	5	0V <sub>VAL/OUT</sub>	Load voltage supply (valves/outputs)

System overview – IO-Link

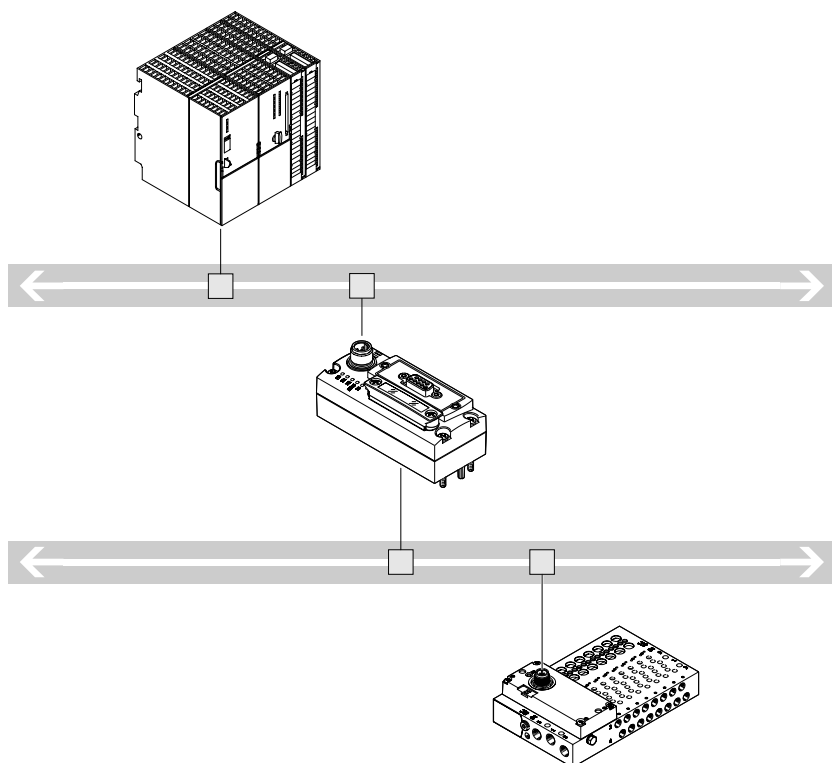

- Communication with higher-order controller via fieldbus
- Use a bus node CTEU compatible with the fieldbus protocol
- Up to 64 inputs/outputs (solenoid coils), depending on the valve terminal
- No preprocessing

Data sheet – I-Port interface/IO-Link

Dimensions

Download CAD data → [www.festo.com](http://www.festo.com)

I-Port interface, outlet on top

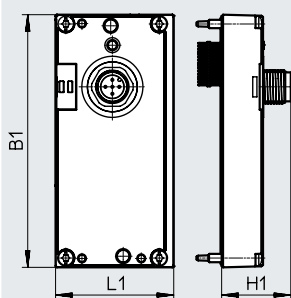

-  - **Note**

Dimensions of the manifold rail with electrical connection → page 157

I-Port interface, outlet on side

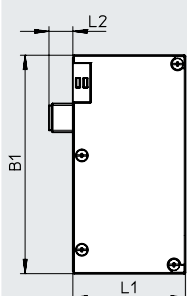





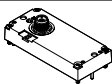

-  - **Note**

Dimensions of the manifold rail with electrical connection → page 157

Type	Outlet on top			Outlet on the side		
	B1	L1	H1	B1	L1	L2
VAEM-L1-S-...	91	42.5	25	91.5	47.1	10

Ordering data

	Description	Part no.	Type
<b>Electrical interface for I-Port interface/IO-Link, outlet on top</b>			
	Actuation of up to 8 double solenoid valve positions	573384	VAEM-L1-S-8-PT
	Actuation of up to 16 double solenoid valve positions	573939	VAEM-L1-S-16-PT
	Actuation of up to 24 double solenoid valve positions	573940	VAEM-L1-S-24-PT
<b>Electrical interface for I-Port interface/IO-Link, outlet at side</b>			
	Actuation of up to 8 double solenoid valve positions	574207	VAEM-L1-S-8-PTL
	Actuation of up to 16 double solenoid valve positions	574208	VAEM-L1-S-16-PTL
	Actuation of up to 24 double solenoid valve positions	574209	VAEM-L1-S-24-PTL
<b>Connection technology for IO-Link</b>			
	T-adapter M12, 5-pin for IO-Link and load supply	171175	FB-TA-M12-5POL
	Straight plug M12, 5-pin, for T-adapter FB-TA	175487	SEA-M12-5GS-PG7
	Y-distributor with cable on controller side, M12x1 A coded, for IO-Link	8091516	NEDU-L1R2-M12G5-M12LE-1R
<b>Inscription label for I-Port interface/IO-Link</b>			
	40 pieces in frame	565306	ASLR-C-E4

Valve terminal VTUG, electrical connection block CAPC

Data sheet – CAPC

**Function**

The electrical connection block CAPC enables the decentralised installation of bus nodes CTEU on a valve terminal or input modules with I-Port interface.

**Scope**

- M12 connection technology (two interfaces)
- Enables the installation of valve terminals or other devices over a distance of 20 metres
- By using the accessory CAFM, the connection block can be installed on an H-rail



**General technical data**

Type	CAPC-F1-E-M12	
Dimensions W x L x H	[mm]	50 x 148 x 28
Fieldbus interface	2x M12 socket, 5-pin	
Operating voltage range	[V DC]	18 ... 30
Max. power supply	[A]	2
Nominal operating voltage	[V DC]	24
Product weight	[g]	85
Cable length	[m]	20

**Materials**

Housing	Reinforced PA
Note on materials	RoHS-compliant

**Operating and environmental conditions**

Degree of protection to EN 60529	IP65, IP67	
Ambient temperature	[°C]	-5 ... +50
Storage temperature	[°C]	-20 ... +70
Corrosion resistance CRC <sup>1)</sup>	2	
CE marking (see declaration of conformity) <sup>2)</sup>	To EU EMC Directive	

- 1) Corrosion resistance class CRC 2 to Festo standard FN 940070  
Moderate corrosion stress. Indoor applications in which condensation can occur. External visible parts with primarily decorative surface requirements which are in direct contact with a normal industrial environment.
- 2) For information about the area of use, see the EC declaration of conformity: [www.festo.com/sp](http://www.festo.com/sp) → Certificates.  
If the devices are subject to usage restrictions in residential, commercial or light-industrial environments, further measures for the reduction of the emitted interference may be necessary.

**Pin allocation – Power supply/IO-Link interfaces**

	Pin	Allocation	Description
	1	24V <sub>EL/SEN</sub>	Operating voltage supply (electronics, sensors/inputs)
	2	24V <sub>VAL/OUT</sub>	Load voltage supply (valves/outputs)
	3	0V <sub>EL/SEN</sub>	Operating voltage supply (electronics, sensors/inputs)
	4	C/Q	Data communication
	5	0V <sub>VAL/OUT</sub>	Load voltage supply (valves/outputs)
			Housing, FE

Data sheet – CAPC

Dimensions

CAPC

Download CAD data → [www.festo.com](http://www.festo.com)

CAPC with mounted bus node CTEU-CO

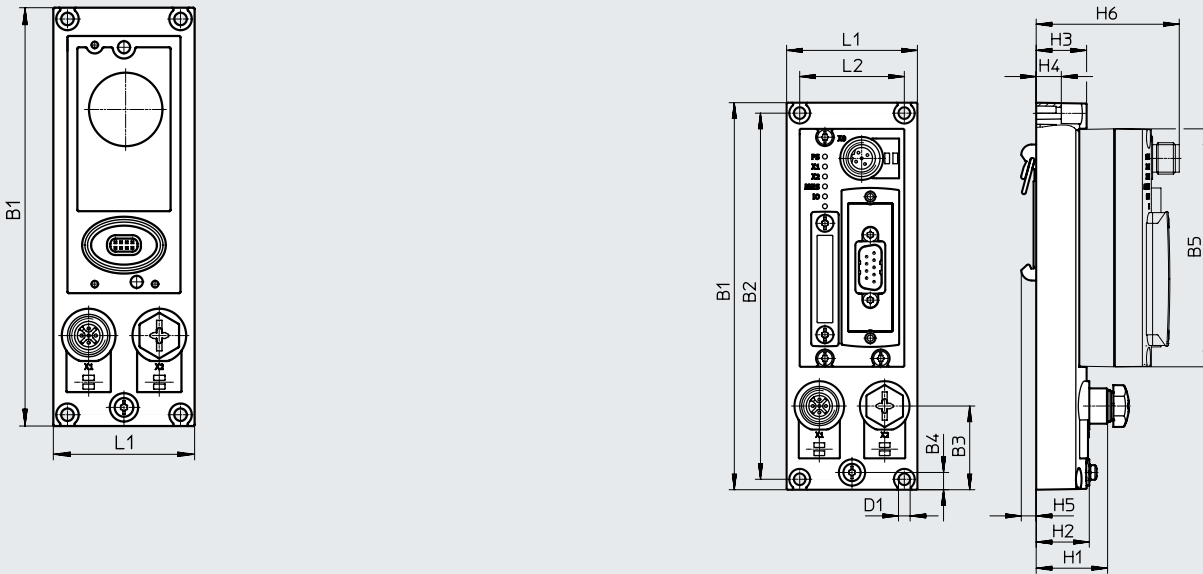

Type	B1	B2	B3	B4	B5	D1 $\varnothing$	H1	H2	H3	H4	H5	H6	L1	L2
CAPC	148	140	32	6.6	91	4.4	27.3	20.3	19.3	9.6	5.7	54.8	50	40

Ordering data

Part no. Type

Electrical connection block

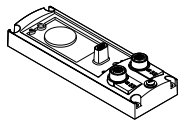

For connecting a second device with I-Port interface

570042

CAPC-F1-E-M12

H-rail mounting

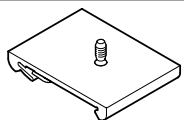

For electrical connection block CAPC

570043

CAF-M-F1-H

Valve terminal VTUG with interlock

Data sheet – Interlock

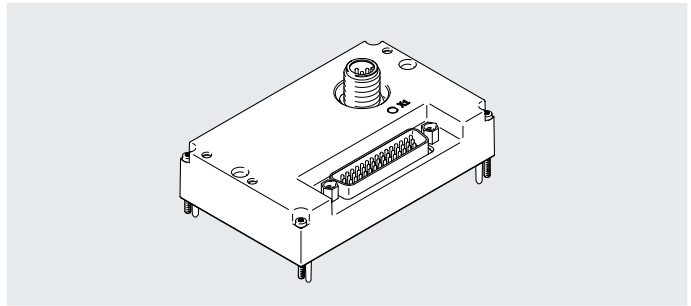

**Interlock**

The interlock function enables the first 16 solenoid coils to be individually supplied externally.

This guarantees the safe release of these valves.

The interlock interface is established via external contacts for a single-pin connection or via safety output terminals for a double-pin connection.

**General technical data**

Types of communication		I-Port/IO-Link
Number of valve positions		4...24
Max. number of solenoid coils		48
Number of interlock solenoid coils		16
Number of inputs for reading back voltage		18 (16x interlock + 2 group supply)
Mounting position		Any
Nominal flow rate	[l/min]	330
Product weight	[g]	80
Residual ripple	[V <sub>SS</sub> ]	4
Baud rate	COM3	[kbps] 230.4
	COM2	[kbps] 38.4
IO-Link	Protocol	V1.0
	Connection technology	M12, A-coded
	Port type	Type B
	Number of ports	1
	Process data width OUT	6 bytes
	Process data width IN	4 bytes
Minimum cycle time		11.5 ms (2.3 ms per frame = 2 bytes of user data)
Corrosion resistance class CRC <sup>1)</sup>		2

1) Corrosion resistance class CRC 2 to Festo standard FN 940070

Moderate corrosion stress. Indoor applications in which condensation can occur. External visible parts with primarily decorative surface requirements which are in direct contact with a normal industrial environment.



Data sheet – Interlock

Interlock interface

Single-pin interlock interface

- The interlock interface is established via external positive switching contacts or single-pin switching safety terminals
- 16 solenoid coils can be actuated via the interlock (Vn+)
- Solenoid coils that do not require interlock actuation can be supplied directly with 24 V from pins 1 ... 3
- Application of the respective input voltage is reported via the fieldbus as a process image

Double-pin interlock interface

- The interlock interface is established via external positive-negative switching safety terminals
- The solenoid coils of the interlock valves are actuated via the corresponding pins in the sub-D plug (pins 7 ... 38)
- The solenoid coils that do not require interlock actuation can be supplied directly with 24 V (e.g. from pins 1 ... 3)
- Any difference in potential between Vn- and 0 VVAL/OUT must be below 5 V

Sample circuit diagram for a single-pin interlock interface

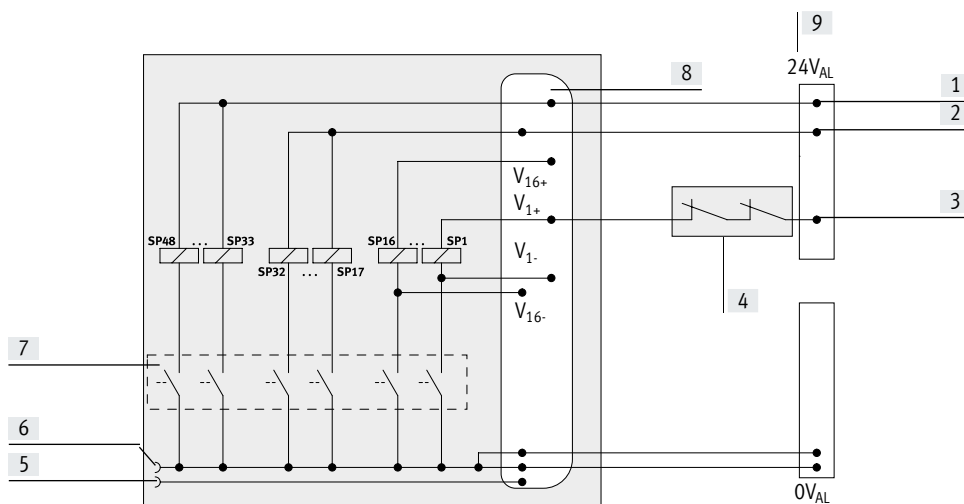

- [1] Power supply V+; solenoid coil 33 ... 48, (no interlock)
- [2] Power supply V+; solenoid coil 17 ... 32, (no interlock)
- [3] Actuation Vn+ (via interlock)
- [4] Interlock contacts of the output terminal
- [5] I-Port connection pin 2, 24 VVAL/OUT (PL), load voltage supply
- [6] I-Port connection pin 5, 0 VVAL/OUT (PL), load voltage supply
- [7] Driver, actuated via fieldbus/I-Port
- [8] Interlock Sub-D connection
- [9] Power supply (interlock)

Sample circuit diagram for a double-pin interlock interface

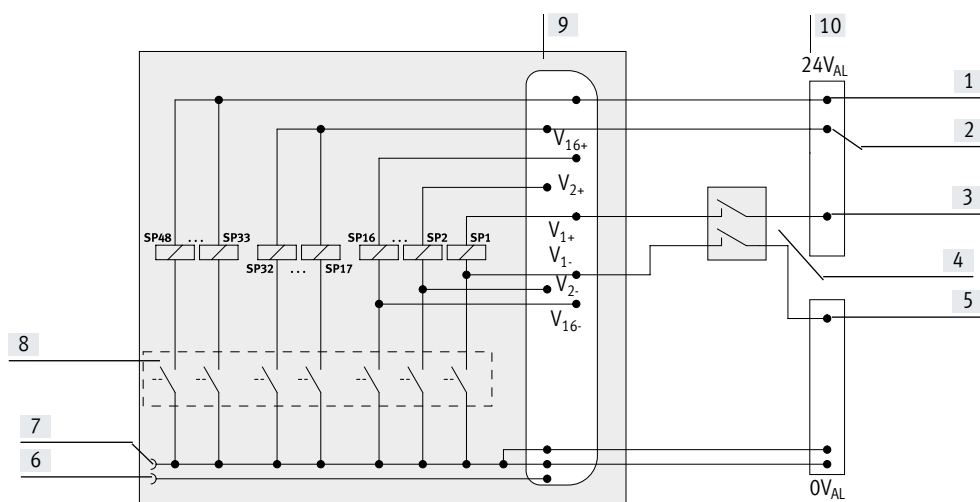

- [1] Power supply V+; solenoid coil 33 ... 48, (no interlock)
- [2] Power supply V+; solenoid coil 17 ... 32, (no interlock)
- [3] Actuation Vn+ (via interlock)
- [4] Interlock contacts of the output terminal
- [5] Actuation Vn- (via interlock)
- [6] I-Port connection pin 2, 24 VVAL/OUT (PL), load voltage supply
- [7] I-Port connection pin 5, 0 VVAL/OUT (PL), load voltage supply
- [8] Driver, actuated via fieldbus/I-Port
- [9] Interlock Sub-D connection
- [10] Power supply (interlock)

Valve terminal VTUG with interlock

Data sheet – Interlock

**Pin allocation – Interlock**

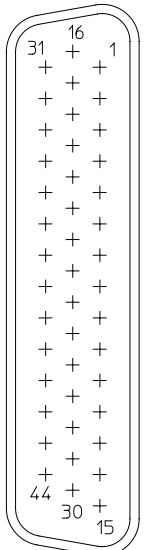

Pin	Coil	Signal	Pin	Coil	Signal	Pin	Coil	Signal
1	-	24 V <sub>VAL/OUT</sub>	16	5	V5-	31	13	V13+
2	-	24 V <sub>VAL/OUT</sub>	17	6	V6+	32	13	V13-
3	-	24 V <sub>VAL/OUT</sub>	18	6	V6-	33	14	V14+
4	1 ... 48	0 V <sub>VAL/OUT</sub>	19	7	V7+	34	14	V14-
5	1 ... 48	0 V <sub>VAL/OUT</sub>	20	7	V7-	35	15	V15+
6	1 ... 48	0 V <sub>VAL/OUT</sub>	21	8	V8+	36	15	V15-
7	1	V1+	22	8	V8-	37	16	V16+
8	1	V1-	23	9	V9+	38	16	V16-
9	2	V2+	24	9	V9-	39	17 ... 32	V17 ... 32+
10	2	V2-	25	10	V10+	40	33 ... 48	V33 ... 48+
11	3	V3+	26	10	V10-	41	1 ... 48	0 V <sub>VAL/OUT</sub>
12	3	V3-	27	11	V11+	42	1 ... 48	0 V <sub>VAL/OUT</sub>
13	4	V4+	28	11	V11-	43	1 ... 48	0 V <sub>VAL/OUT</sub>
14	4	V4-	29	12	V12+	44	-	n.c.
15	5	V5+	30	12	V12-	Housing		FE

**Pin allocation – I-Port interface/IO-Link**

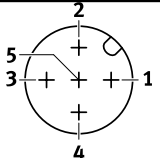



Pin	Allocation	Description
1	24V <sub>EL/SEN</sub>	Operating voltage supply (electronics, sensors/inputs)
2	24V <sub>VAL/OUT</sub>	Load voltage supply (valves/outputs)
3	0V <sub>EL/SEN</sub>	Operating voltage supply (electronics, sensors/inputs)
4	C/Q	Data communication
5	0V <sub>VAL/OUT</sub>	Load voltage supply (valves/outputs)
Housing, FE		Functional earth

Dimensions

I-Port interface with interlock, outlet on top

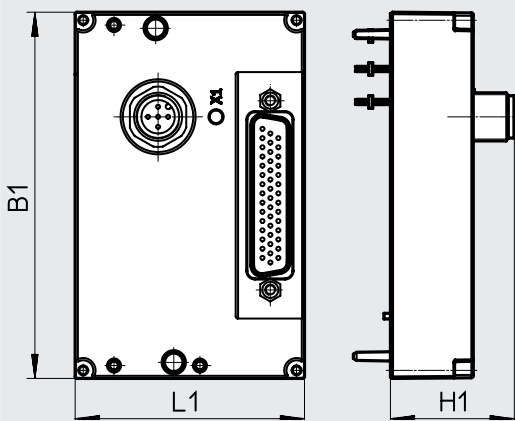

Download CAD data → [www.festo.com](http://www.festo.com)



 **Note**  
 Dimensions of the manifold rail with electrical connection → page 157

Type	Outlet on top		
	B1	L1	H1
VAEM-L1-S-24-PTK	91	57	30.8

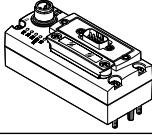
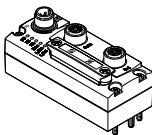
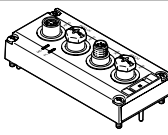
Accessories – Valve terminal

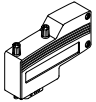
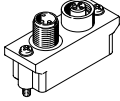
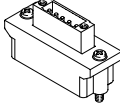
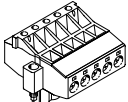
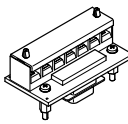
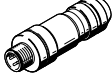
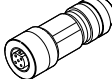
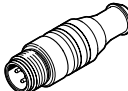

Ordering data – CTEU		Description	Part no.	Type
<b>Bus node</b>				
	CANopen bus node		570038	CTEU-CO
	CC-Link bus node		1544198	CTEU-CC
	PROFIBUS bus node		570040	CTEU-PB
	DeviceNet bus node		570039	CTEU-DN
	EtherCAT bus node		572556	CTEU-EC
	EtherNet/IP bus node		2798071	CTEU-EP
<b>Electrical interface</b>				
	For direct integration of the valve terminal into the decentralised IO system CPX-API		8081922	VAEM-L1-S-12-AP
			8081923	VAEM-L1-S-24-AP
<b>Bus connection</b>				
	Sub-D plug, straight	For CANopen	532219	FBS-SUB-9-BU-2x5POL-B
		For CC-Link	532220	FBS-SUB-9-GS-2x4POL-B
		For PROFIBUS	532216	FBS-SUB-9-GS-DP-B
	Sub-D plug, angled, 9-pin	For CANopen	533783	FBS-SUB-9-WS-CO-K
		For PROFIBUS	533780	FBS-SUB-9-WS-PB-K
	M12x1, 5-pin	A-coded, for CANopen	525632	FBA-2-M12-5POL
		B-coded, for PROFIBUS	533118	FBA-2-M12-5POL-RK
	For 5-pin terminal strip for CANopen		525634	FBA-1-SL-5POL
	Terminal strip, 5-pin, for DeviceNet/CANopenS		525635	FBSD-KL-2x5POL
	Screw terminal for CC-Link		197962	FBA-1-KL-5POL
	Straight plug, M12x1	5-pin, for CANopen	175380	FBS-M12-5GS-PG9
		4-pin, D-coded for EtherCAT	543109	NECU-M-S-D12G4-C2-ET
		5-pin, compatible with FBA-2-M12-5POL-RK for PROFIBUS	1066354	NECU-M-S-B12G5-C2-PB
	Straight socket, M12x1, 5-pin, for assembling a connecting cable compatible with FBA-2-M12-5POL-RK for PROFIBUS		1067905	NECU-M-B12G5-C2-PB
	Terminating resistor, M12, B-coded for PROFIBUS		1072128	CACRS-B12G5-220-PB

Valve terminal VTUG with multi-pin plug connection and fieldbus interface

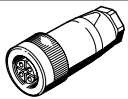
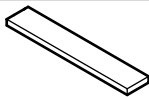
Accessories – Valve terminal

Ordering data – CTEU			
	Description	Part no.	Type
<b>Plug socket</b>			
	For power supply, M12x1, 5-pin, B-coded for CANopen/DeviceNet	538999	NTSD-GD-9-M12-5POL-RK
	For power supply, M12x1, 5-pin for CC-Link, PROFIBUS, EtherCAT	18324	FBSD-GD-9-5POL
<b>Inscription label</b>			
	For bus node	565306	ASLR-C-E4

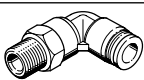
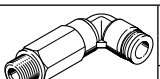
Accessories – Valve terminal

Ordering data		Description	Part no.	Type	PU <sup>1)</sup>	
		Data sheets → Internet: qsm				
<b>Push-in fitting, straight</b>						
	M5 thread	For tubing Ø 3 mm	–	153313	QSM-M5-3-I	10
		Round releasing ring	–	133003	QSM-M5-3-I-R	10
	M5 thread	For tubing Ø 4 mm	–	★ 153315	QSM-M5-4-I	10
		Round releasing ring	–	133004	QSM-M5-4-I-R	10
	M7 thread	For tubing Ø 4 mm	–	★ 153319	QSM-M7-4-I	10
		Round releasing ring	–	133007	QSM-M7-6-I-R	10
	G1/8 thread	For tubing Ø 4 mm	–	★ 186106	QS-G1/8-4-I	10
		For tubing Ø 6 mm	–	★ 186107	QS-G1/8-6-I	10
		For tubing Ø 8 mm	–	★ 186109	QS-G1/8-8-I	10
	1/8 thread	For tubing Ø 10 mm	–	★ 190647	QS-1/8-10-I	10
	1/4 thread	For tubing Ø 8 mm	–	132280	QS-B-1/4-8-I	1
			–	★ 153016	QS-1/4-8-I	10
		For tubing Ø 10 mm	–	132842	QS-B-1/4-10-I	1
			–	★ 153018	QS-1/4-10-I	10
		For tubing Ø 12 mm	–	★ 190649	QS-1/4-12-I	10
	R3/8 thread	For tubing Ø 8 mm	–	130681	QS-3/8-8-50	50
		For tubing Ø 10 mm	–	130682	QS-3/8-10-50	50
		For tubing Ø 12 mm	–	130683	QS-3/8-12-20	20
For tubing Ø 16 mm		–	164957	QS-3/8-16	1	
		Data sheets → Internet: qsl				
<b>Push-in fitting, angled</b>						
	M5 thread	For tubing Ø 3 mm	–	153331	QSML-M5-3	10
		For tubing Ø 4 mm	–	★ 153333	QSML-M5-4	10
	M7 thread	For tubing Ø 4 mm	–	★ 186352	QSML-M7-4	10
	G1/8 thread	For tubing Ø 6 mm	–	★ 186117	QSL-G1/8-6	10
		For tubing Ø 8 mm	–	★ 186119	QSL-G1/8-8	10
	1/8 thread	For tubing Ø 10 mm	–	★ 190658	QSL-1/8-10	10
		For tubing Ø 6 mm	–	130765	QSML-1/8-6-100	100
	1/4 thread	For tubing Ø 8 mm	–	132220	QSL-B-1/4-8	1
		For tubing Ø 8 mm	–	130732	QSL-1/4-8-50	50
		For tubing Ø 10 mm	–	132817	QSL-B-1/4-10	1
For tubing Ø 10 mm		–	130733	QSL-1/4-10-50	50	
For tubing Ø 12 mm	–	130734	QSL-1/4-12-20	20		
		Data sheets → Internet: qsl				
<b>Push-in fitting, long, angled</b>						
	M5 thread	For tubing Ø 3 mm	–	130838	QSMLL-M5-3	10
		For tubing Ø 4 mm	–	153339	QSMLL-M5-4	10
	M7 thread	For tubing Ø 4 mm	–	186354	QSMLL-M7-4	10
	G1/8 thread	For tubing Ø 6 mm	–	186128	QSLL-G1/8-6	10
		For tubing Ø 8 mm	–	186130	QSLL-G1/8-8	10
		Data sheets → Internet: b				
<b>Blanking plug</b>						
	For M5 thread			★ 174308	B-M5-B	10
	For M7 thread			★ 174309	B-M7	10
	For G1/8 thread			★ 3568	B-1/8	10
	For G1/4 thread			★ 3569	B-1/4	10
	For G1/8 thread			196720	CDVI5.0-B-G1/8	1
	For G3/8 thread			196712	CDVI5.0-B-G3/8	1
	For G1/4 thread			8035644	CDVI5.0-B-G1/4	1

1) Packaging unit.

Festo core product range











Generally ready for dispatch from the factory within 24 hours

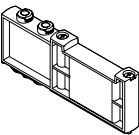
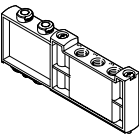

Generally ready for dispatch from the factory within 5 days

Valve terminal VTUG with multi-pin plug connection and fieldbus interface

Accessories – Valve terminal

Ordering data		Description	Part no.	Type	PU <sup>1)</sup>
Silencer <span style="float: right;">Data sheets → Internet: amte</span>					
	For M3 thread		1231120	AMTE-M-LH-M3	20
	For M5 thread		★ 1205858	AMTE-M-LH-M5	20
	For M7 thread		161418	UC-M7	1
	For G1/8 thread	High flow rate	★ 2307	U-1/8	1
		Lower flow rate	161419	UC-1/8	1
	For G1/4 thread	High flow rate	★ 2316	U-1/4	1
			534223	U-1/4-20	20
		Lower flow rate	165004	UC-1/4	1
		534220	UC-1/4-20	20	
Cover plate					
	Vacant position width 10 mm		573422	VABB-L1-10-T	1
	Vacant position width 14 mm		573488	VABB-L1-14-T	1
	Vacant position width 18 mm		8004897	VABB-L1-18-T	1
Supply plate					
	Supply ports 1, 3, 5, width 10 mm		573924	VABF-L1-10-P3A4-M7-T1	1
	Supply ports 1, 3, 5, width 14 mm		573925	VABF-L1-14-P3A4-G18-T1	1
	Supply ports 1, 3, 5, width 18 mm		8004898	VABF-L1-18-P3A4-G14-T1	1
Separator					
	For manifold rail, size 10, M5/M7	For sub-base valves	569994	VABD-6-B	1
		For semi in-line valves	569995	VABD-8-B	1
	For all manifold rails, size 14		569996	VABD-10-B	1
	For all manifold rails, size 18		569997	VABD-12-B	1
Cover cap for manual override					
	Covered		540898	VMPA-HBV-B	10
	Non-detenting		540897	VMPA-HBT-B	10
	Detenting (without accessories)		8002234	VAMC-L1-CD	10
Identification holder <span style="float: right;">Data sheets → Internet: aslr</span>					
	Holder for an inscription label and cover for the retaining screw and manual override		570818	ASLR-D-L1	10

Festo core product range







Generally ready for dispatch from the factory within 24 hours

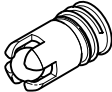

Generally ready for dispatch from the factory within 5 days

Accessories – Valve terminal

Ordering data		Description	Part no.	Type	PJ <sup>1)</sup>	
<b>Check valve</b>						
	For manifold rails VABM-L1-10...	For blocking the flow in the event of back pressure in duct 3 and 5	<b>8047364</b>	<b>VABF-L1-10H-H2</b>	10	
	For manifold rails VABM-L1-14...		<b>8047365</b>	<b>VABF-L1-14-H2</b>	10	
<b>Flow restrictor</b>						
	For manifold rails VABM-L1-10...	For setting the flow rate for pressurisation and exhausting (for threaded connection M5)	Nominal size: 0.5 mm	<b>8025709</b>	<b>VFFG-T-M5-5</b>	10
			Nominal size: 0.6 mm	<b>8025710</b>	<b>VFFG-T-M5-6</b>	10
			Nominal size: 0.7 mm	<b>8025711</b>	<b>VFFG-T-M5-7</b>	10
			Nominal size: 0.85 mm	<b>8025712</b>	<b>VFFG-T-M5-8</b>	10
			Nominal size: 1.05 mm	<b>8025713</b>	<b>VFFG-T-M5-10</b>	10
			Nominal size: 1.2 mm	<b>8025714</b>	<b>VFFG-T-M5-12</b>	10
		For setting the flow rate for pressurisation and exhausting (for $\varnothing$ 4 mm)	Nominal size: 0.5 mm	<b>8047346</b>	<b>VFFG-T-F4-5</b>	10
			Nominal size: 0.6 mm	<b>8047347</b>	<b>VFFG-T-F4-6</b>	10
			Nominal size: 0.7 mm	<b>8047348</b>	<b>VFFG-T-F4-7</b>	10
			Nominal size: 0.85 mm	<b>8047349</b>	<b>VFFG-T-F4-8</b>	10
			Nominal size: 1.05 mm	<b>8047350</b>	<b>VFFG-T-F4-10</b>	10
			Nominal size: 1.2 mm	<b>8047351</b>	<b>VFFG-T-F4-12</b>	10
	For manifold rails VABM-L1-14...	For setting the flow rate for pressurisation and exhausting (for $\varnothing$ 5.8 mm)	Nominal size: 1.55 mm	<b>8025715</b>	<b>VFFG-T-M5-15</b>	10
			Nominal size: 0.7 mm	<b>8047353</b>	<b>VFFG-T-F6-7</b>	10
			Nominal size: 0.85 mm	<b>8047354</b>	<b>VFFG-T-F6-8</b>	10
			Nominal size: 1.05 mm	<b>8047355</b>	<b>VFFG-T-F6-10</b>	10
			Nominal size: 1.15 mm	<b>8047356</b>	<b>VFFG-T-F6-11</b>	10
			Nominal size: 1.4 mm	<b>8047357</b>	<b>VFFG-T-F6-14</b>	10
		Nominal size: 1.6 mm	<b>8047358</b>	<b>VFFG-T-F6-16</b>	10	
		Nominal size: 1.8 mm	<b>8047359</b>	<b>VFFG-T-F6-18</b>	10	
<b>Flow control set</b>						
	For manifold rails VABM-L1-10...	Two of each size, for threaded connection M5	<b>8025716</b>	<b>VFFG-T-M5-A-V1</b>	14	
		Two of each size, for $\varnothing$ 4 mm	<b>8062200</b>	<b>VFFG-T-F4-A-V1</b>	14	
	For manifold rails VABM-L1-14...	Two of each size, for $\varnothing$ 5.8 mm	<b>8062201</b>	<b>VFFG-T-F6-A-V1</b>	14	

1) Packaging unit.

Valve manifold VTUG with multi-pin plug connection and fieldbus interface

Accessories – Valve terminal

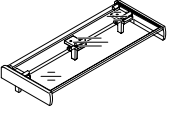
Ordering data	Description	Part no.	Type
Inscription label holder for valve terminal			
	Size 10	For 4 valve positions	573453 ASCF-H-L1-10-4V
		For 5 valve positions	573454 ASCF-H-L1-10-5V
		For 6 valve positions	573455 ASCF-H-L1-10-6V
		For 7 valve positions	573456 ASCF-H-L1-10-7V
		For 8 valve positions	573457 ASCF-H-L1-10-8V
		For 9 valve positions	573458 ASCF-H-L1-10-9V
		For 10 valve positions	573459 ASCF-H-L1-10-10V
		For 12 valve positions	573460 ASCF-H-L1-10-12V
		For 16 valve positions	573461 ASCF-H-L1-10-16V
		For 20 valve positions	573462 ASCF-H-L1-10-20V
		For 24 valve positions	573463 ASCF-H-L1-10-24V
		Size 14	For 4 valve positions
	For 5 valve positions		573512 ASCF-H-L1-14-5V
	For 6 valve positions		573513 ASCF-H-L1-14-6V
	For 7 valve positions		573514 ASCF-H-L1-14-7V
	For 8 valve positions		573515 ASCF-H-L1-14-8V
	For 9 valve positions		573516 ASCF-H-L1-14-9V
	For 10 valve positions		573518 ASCF-H-L1-14-10V
	For 12 valve positions		573519 ASCF-H-L1-14-12V
	For 16 valve positions		573520 ASCF-H-L1-14-16V
	For 20 valve positions		573521 ASCF-H-L1-14-20V
	For 24 valve positions		573522 ASCF-H-L1-14-24V
	Size 18		For 4 valve positions
		For 5 valve positions	8004929 ASCF-H-L1-18-5V
		For 6 valve positions	8004930 ASCF-H-L1-18-6V
		For 7 valve positions	8004931 ASCF-H-L1-18-7V
		For 8 valve positions	8004932 ASCF-H-L1-18-8V
		For 9 valve positions	8004933 ASCF-H-L1-18-9V
		For 10 valve positions	8004934 ASCF-H-L1-18-10V
		For 12 valve positions	8004935 ASCF-H-L1-18-12V
For 16 valve positions		8004936 ASCF-H-L1-18-16V	
For 20 valve positions		8004937 ASCF-H-L1-18-20V	
For 24 valve positions		8004938 ASCF-H-L1-18-24V	

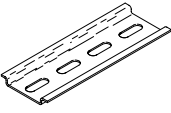
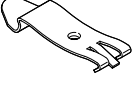
Ordering data	Description	Part no.	Type
H-rail <span style="float: right;">Data sheets → Internet: nrh</span>			
	To EN 60715, 35 x 7.5 (WxH)	Length 2 m	35430 NRH-35-2000
H-rail mounting <span style="float: right;">Data sheets → Internet: vame</span>			
	Use the following screws for mounting: Size 10: DIN 912: M4x30 Size 14: DIN 912: M4x40 Size 18: DIN 912: M5x50	★ 569998	VAME-T-M4

Festo core product range



Generally ready for dispatch from the factory within 24 hours



Generally ready for dispatch from the factory within 5 days