

# linear modules

"Control in motion"

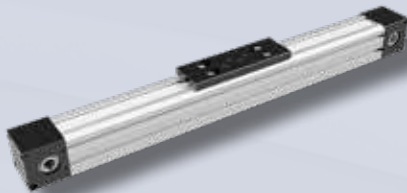
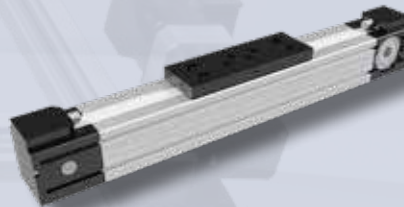
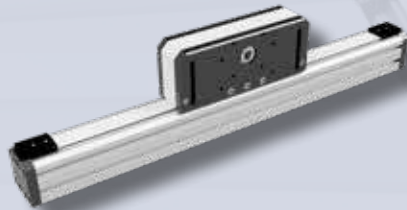
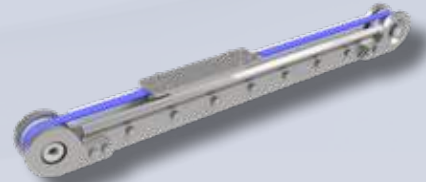
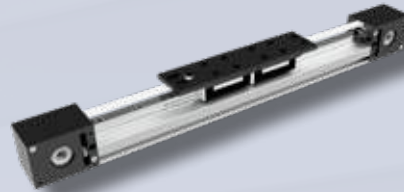
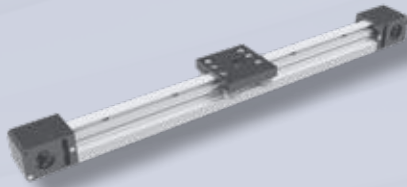

**ALMOTION**<sup>®</sup>

**Almotion bv**

Nijverheidsweg 14  
6662 NG ELST (Gld)  
The Netherlands  
T : 0031 85 0491 777  
E : info@almotion.nl  
I : www.almotion.nl  
I : www.linearmotion.nl  
I : www.lineairegeleiding.nl



Since 1996 Almotion focuses on the development, design and production of linear units. In the industry of linear units they use the name LINEAIRTECHNIEK®, the only Dutch brand that manufactures and develops linear units, they are really "MADE IN HOLLAND" This ensures that a high quality product with fast delivery times, excellent service and flexibility in technical solutions, can be offered.

Because Almotion does the complete process they can offer a very convenient price-product ratio. This allows them, as a specialist, to handle all challenges and make you a customized proposal. Extensive experience with mechanical drive-solutions in engineering provides the customer with the best technical solution.

The industrial linear units are constructed from an aluminium profile on which a carriage is guided by either hardened shafts or circulating ball bearing rails. The toothed belt is of the type proposition AT5 or AT10.

The LT50, 55, 80 and LT2 kit systems are suitable for any brand of rail guide of size 15 respectively 20 for example. It will always fit in the customers standard kit system.



Almotion has its own engineering department, so they can target to the needs of the customer. This allows them to always have of a high level of service by fast delivery and flexibility in your designs.



# PRODUCT OVERVIEW

## EXTERNAL GUIDE UNITS

### LT50 series page 11

**External guide Linear Units, width of the profile 50 mm**

- Hardened guide wheels on hardened shafts -8-, highly resistant to pollution
- Recirculating ball rail guide size -15- for heavy loads
- The G8 wheel guide is also available in stainless steel
- Toothed belt type 16 AT5



### LT2 series page 19

**External guide Linear Units, width of the profile 60 mm**

- Hardened guide wheels on hardened shafts -10-, highly resistant to pollution
- Recirculating ball rail guide size -20- for heavier loads
- The C8 wheel guide is also available in stainless steel
- Toothed belt type 16 AT10



### LTY series page 27

**Double external guide unit, width of the profile 135 or 180 mm**

- Very heavy load capacity
- Basic extrusion profile 45 x 135 or 45 x 180 mm
- Rail Guide system size -20- with 3 or 4 carriages
- Toothed belt type AT10, 16 or 25 mm wide



# PRODUCT OVERVIEW

## INTERNAL GUIDE UNITS

### LT55 series page 33

**Internal guide Linear Units, width of the profile 55 mm**

- Internal recirculating ball rail guide size -15- for heavy loads
- Magnetic switches in T-slot for position detection
- Toothed belt type 25 AT5



### LT60S series page 39

**Internal guide Linear Units, with of the profile 60 mm**

- Internal recirculating ball rail guide size -15- for heavy loads
- Carriage length 180 or 280 mm
- Toothed belt type: 25 AT5



### LT80 series page 45

**Tooth belt driven - ball rail guided units**

- Profile width: 80 mm
- Ball rail guide: size 20
- Toothed belt type: 32 AT10



### LT80S series page 51

**Internal guide unit, width of the profile 80 mm**

- Profile width: 80 mm
- Ball rail guide: size 20
- Toothed belt type: 32 AT10



### LTY200 page 57

**Internal guide unit, with two linear guides**

- Profile width: 200 mm
- 2 ball rail guides size 20
- Toothed belt type: 32AT10



# PRODUCT OVERVIEW

## STAINLESS STEEL UNITS

### LTi45 series page 61

- Stainless steel profile. Width: 45 mm
- Stainless steel guide with rollers (C45) or stainless steel recirculation rail guide size -20-
- Foodgrade toothed belt type: AT10 FDA blue serie



### LTi60 series page 65

- Stainless steel profile. Width: 55 mm
- Stainless steel guide with rollers
- Foodgrade toothed belt type: AT10 FDA blue serie



## OMEGA UNITS

### LTZ50 series page 71

#### Tooth belt driven - ball rail guided units

- Profile width: 50 mm
- Ball rail guide: size 15
- Toothed belt type: 16 AT5



### LTZ55 series page 75

#### Tooth belt driven - ball rail guided units

- Profile width: 55 mm
- Ball rail guide: size 15
- Toothed belt type: 25 AT5



### LTZ80 series page 79

#### Tooth belt driven - ball rail guided units

- Profile width: 80 mm
- Ball rail guide: size 20
- Toothed belt type: 32 AT10



# PRODUCT OVERVIEW

## MODULAR GUIDE UNITS

### LTC series page 86

External guide Linear Units, basic profile 45 x 90,  
90 x 90 or 45 x 135 mm

- Hardened guide wheels on hardened shafts -10- of -20-
- Highly resistant to pollution
- The V10-12-16 wheel guide is also available in stainless steel
- Modular system, many options possible
- Toothed belt type: 16 AT10, 25 AT10 or 50 AT10



### CUSTOMIZED UNITS page 91

LT88 • LT60ZLMS • LT60-2B • LTO



### APPENDIX page 96



# EXTERNAL GUIDE UNITS, STRUCTURAL DESIGN

LT50 LT2 LTY

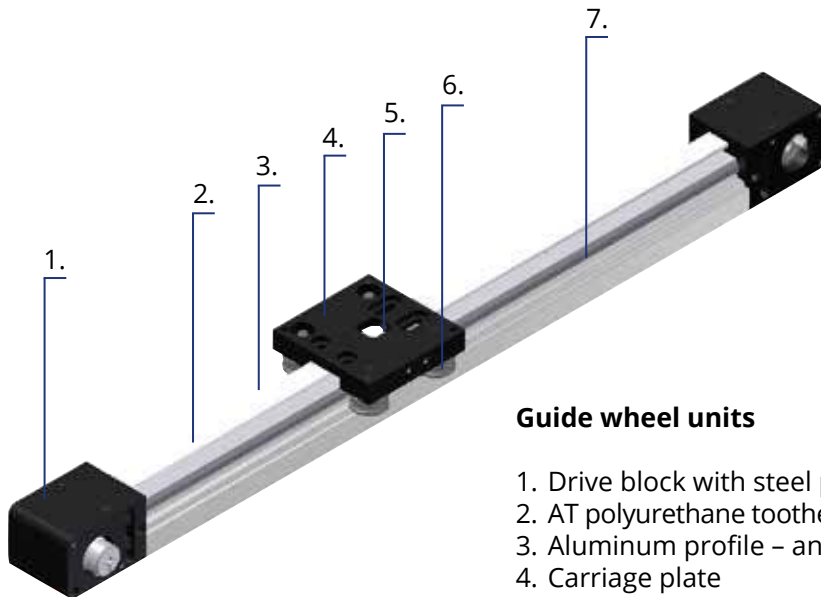

## Guide wheel units

1. Drive block with steel pulley
2. AT polyurethane toothed belt with steel cords
3. Aluminum profile – anodized
4. Carriage plate
5. Belt clamp with belt tensioning system
6. Guide wheel
7. Two hardened steel shafts (60 HCR)

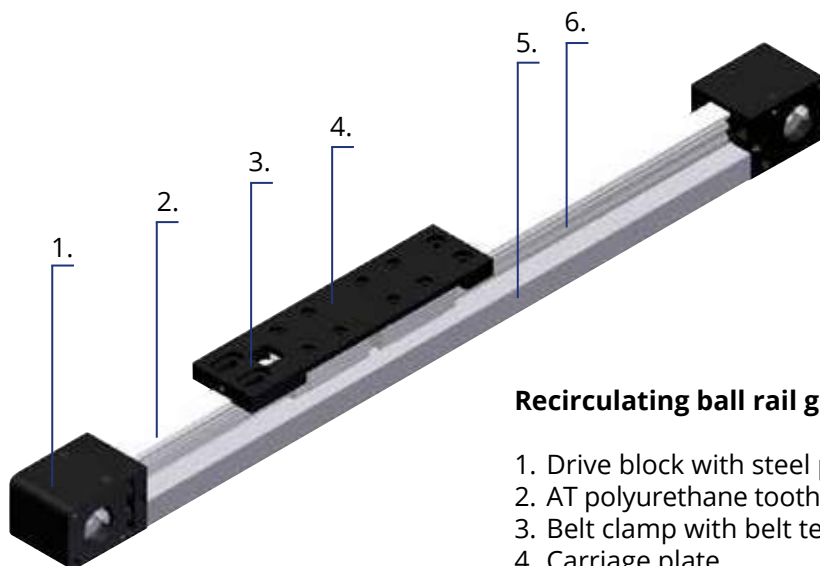

## Recirculating ball rail guide units

1. Drive block with steel pulley
2. AT polyurethane toothed belt with steel cords
3. Belt clamp with belt tensioning system
4. Carriage plate
5. Aluminum profile – anodized
6. Linear ball guide

# CHARACTERISTICS

The LT50, LT2 and LTY series are high performance and low cost linear units with a toothed belt drive and two options of guide system: hardened guide wheel- or ball rail system for simple and precise linear movements. These linear units can also be combined with various multi-axis systems. All the linear units are designed and made in the Netherlands, in consultation with you Almotion can offer the best multi-axis solutions. Also, the linear units can be combined with other systems.

An extruded aluminum profile of anodized Al 6063 alloy with a mounted precision ball rail system enables high load moments and optimum running characteristics to move heavy loads at high speed. The aluminum profile contains T-slots mounting or switch fixing. The linear units LT50, LT2 and LTY uses a pretensioned AT "proposition" polyurethane toothed belt with steel tension cords. This type of linear belt is used together with a zero-backlash pulley to archive an high precision, high load motion.

The carriage can be produced in a custom length with extra fixing holes according to customers wishes. Also available with pre-designed adapters for attachment of the motor and gear box.

**LT50**

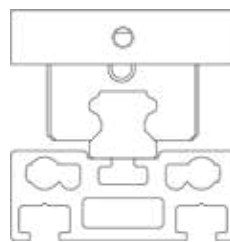
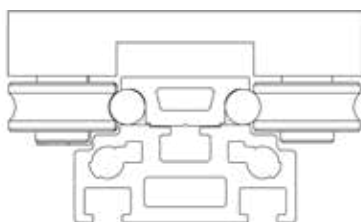

**LT2**

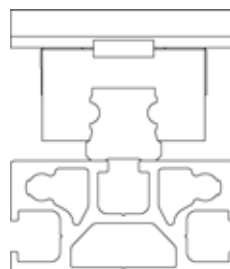
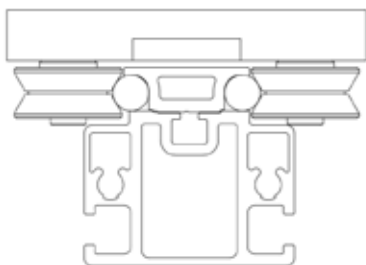

**LTY**

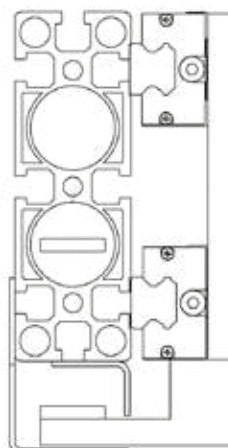
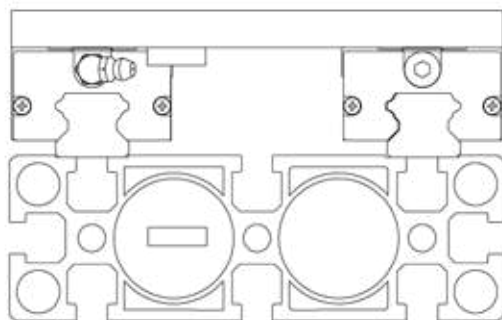



# LT50 SERIES

Robust linear units with  
wheel- or rail guide

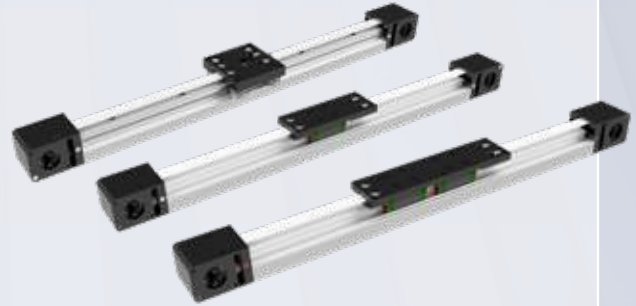

- Compact design, the width of the profile 50 mm
- Guide system of hardened wheels on hardened shafts or rail guide, size -15-
- Toothed belt type AT5, 16 mm wide
- G8 guide wheel systems very resistant to pollution
- Recirculating ball rail guide for heavy loads

## TECHNICAL DATA\*

		LT50-TR-G8	LT50-TR-S15	LT50-TR-S15D
Maximum stroke	mm	5.900	5.800	5.730
Maximum speed	mm/s	5.000	3.000	3.000
Maximum acceleration	m/s <sup>2</sup>	50	30	30
Max. driving torque	Nm	8	8	8
No load torque	Nm	0,2	0,6	0,9
Repeatability	mm	± 0,1	± 0,1	± 0,1
Movement per revolution	mm	100	100	100

\*The values shown are theoretical maximum ratings. A suitable safety factor should always be applied based on application requirements.

# LT50 SERIES

## TECHNICAL DATA

LOAD CAPACITY		LT50-TR-G8	LT50-TR-S15	LT50-TR-S15D
Mx	Nm	11	14	106
My	Nm	11	14	106
Mz	Nm	8	20	40
Fx	N	1.000	1.000	1.000
Fy	N	980	1.700	3.400
Fz	N	850	1.800	3.600

Note: G8 wheel guide also available in stainless steel. S15D is with double carriage.

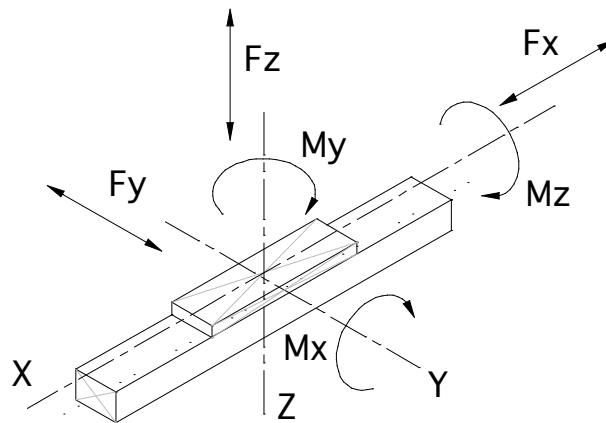

## MOMENT OF INERTIA (NMM<sup>2</sup>)

	LT50-TR-G8	LT50-TR-S15
Elx	4,690*10 <sup>9</sup>	3,257*10 <sup>9</sup>
Ely	8,971*10 <sup>9</sup>	5,786*10 <sup>9</sup>

## WEIGHTS (KG)

	LT50-TR-G8	LT50-TR-S15	LT50-TR-S15D
Unit weight 0 mm stroke	2,43	2,32	2,53
Weight per 100 mm stroke	0,28	0,28	0,28
Mass of carriage	0,33	0,31	0,53

# LT50 SERIES

## DIMENSIONS

### DIMENSIONS LT50-TR-G8

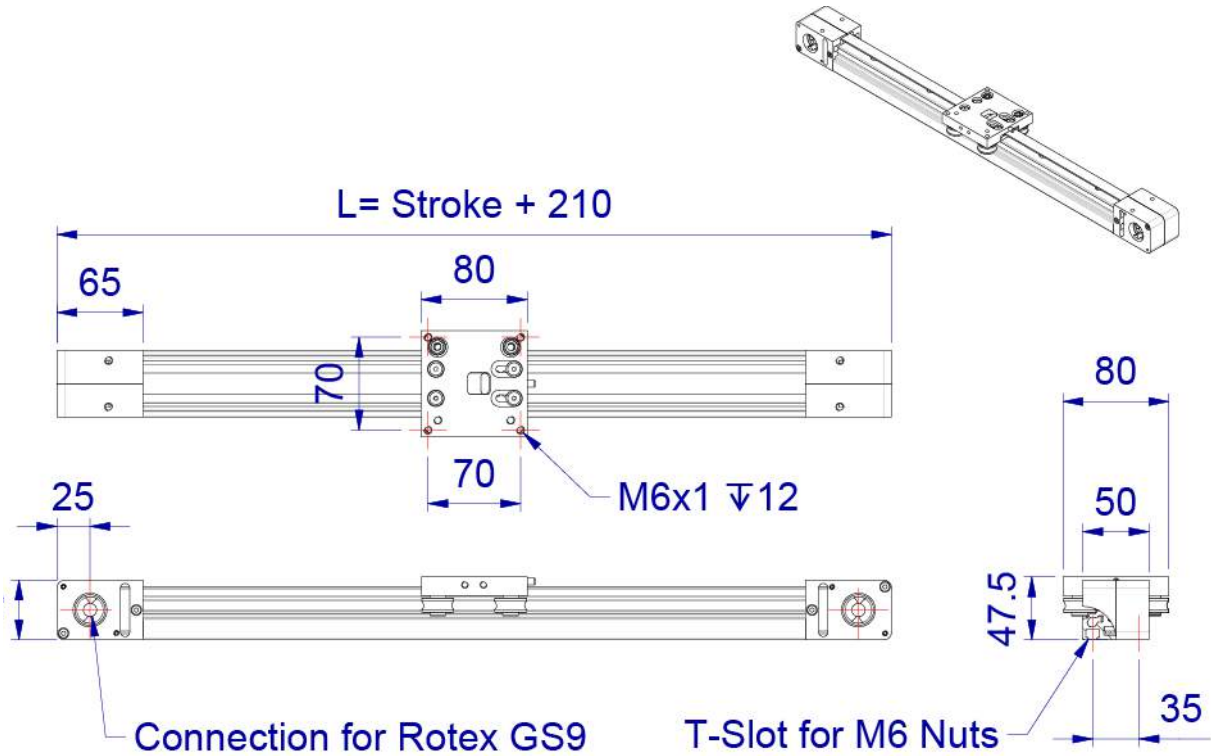

### DIMENSIONS LT50-TR-S15

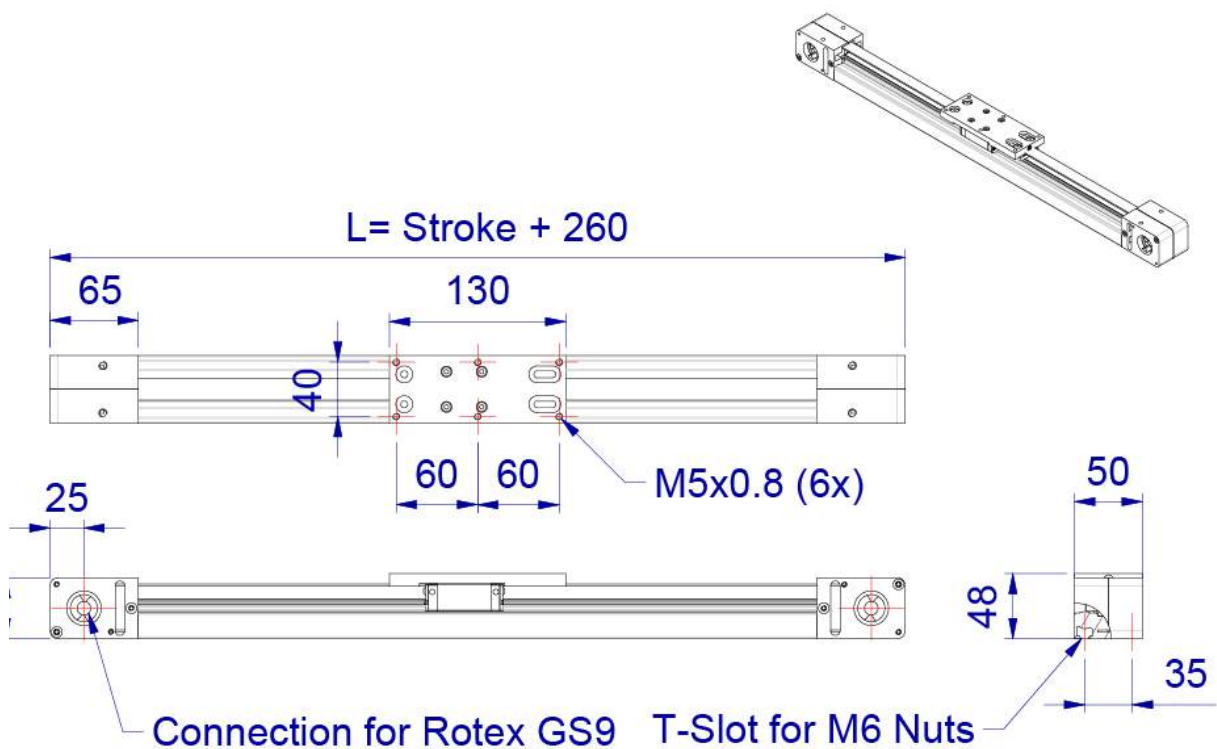

# LT50 SERIES

## DIMENSIONS

### DIMENSIONS LT50-S15-D

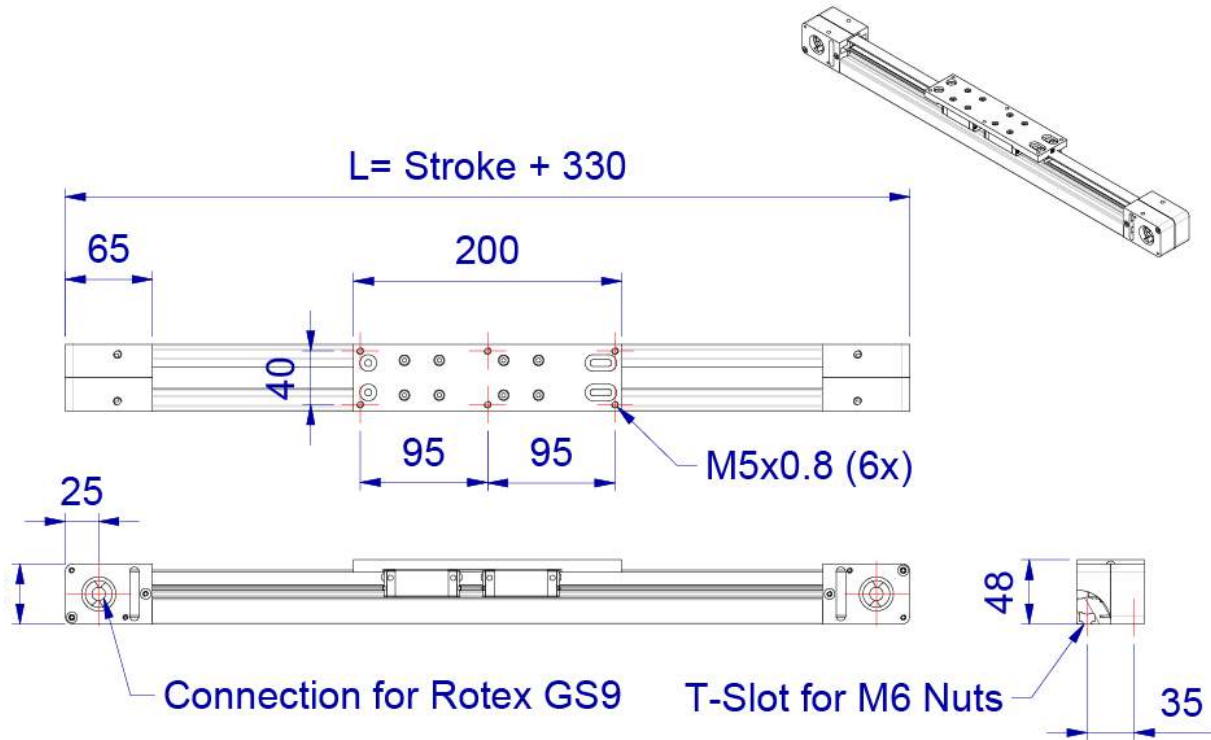

# LT50 SERIES

## MOTOR ACCESSORIES

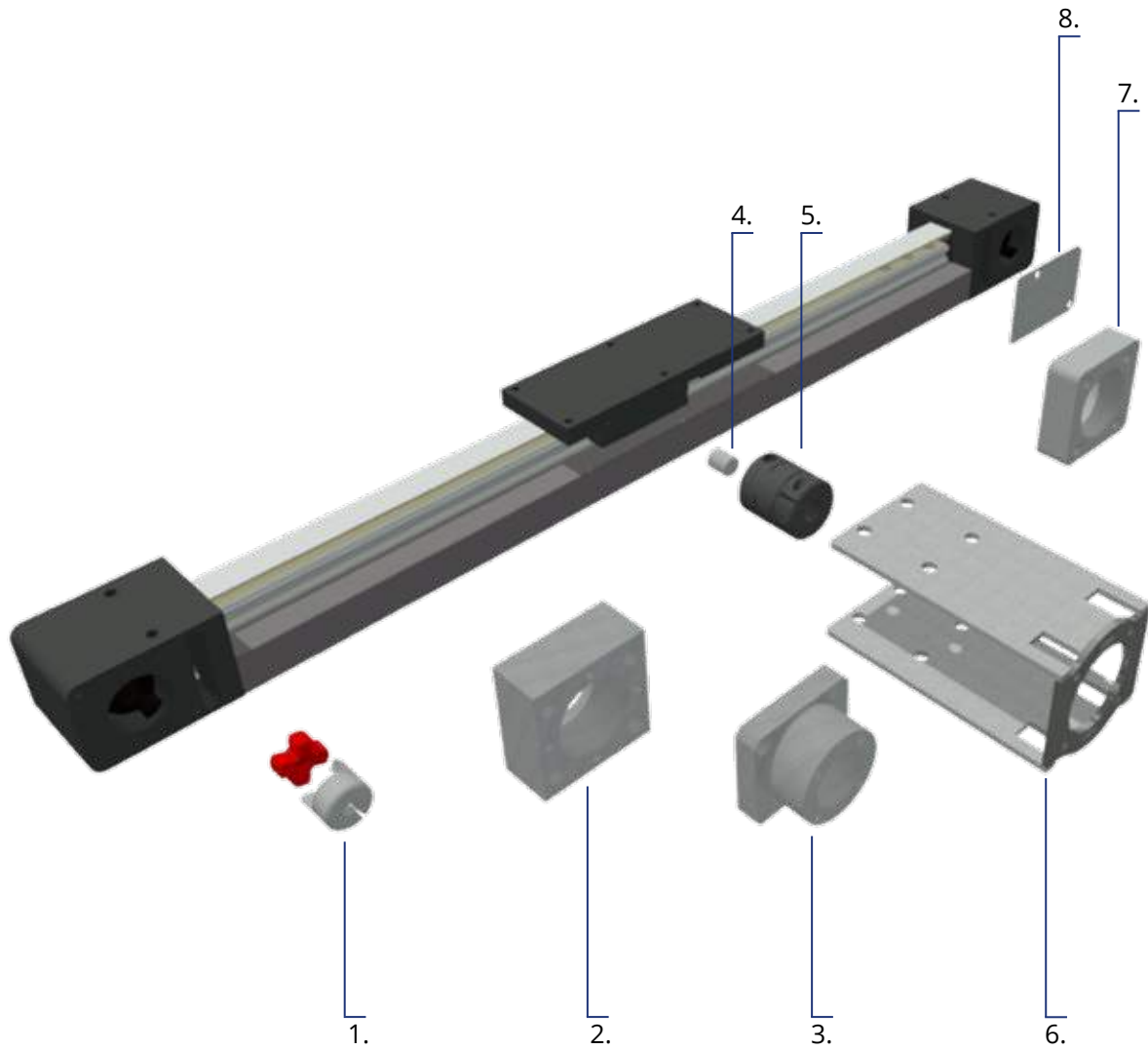

1	Rotex GS9-9/12	Flexible shaft coupling
2	5070-F-XXX	Motor adaptor
3	5070-FL-XXX	Motor adaptor
4	5070-AS10	Interface shaft
5	Rotex GS14-10-14	Flexible shaft coupling
6	5070-F9/14-XXX	Adaptor for motor shaft 14
7	5070-FL-NEMA23	Motor adapter
8	5070-BP	Blank coverplate-ss

# LT50-TR-G8

## ACCESSORIES

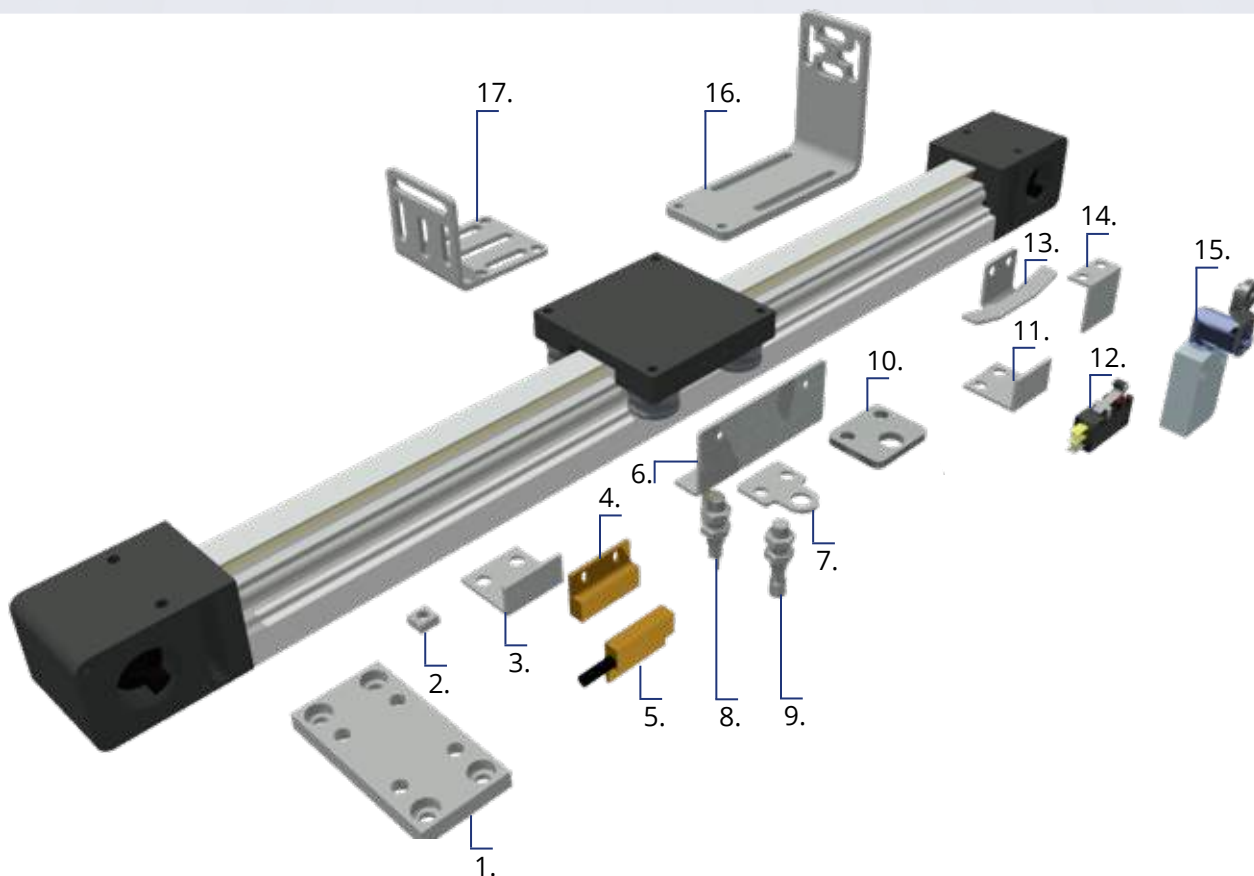

1	5070-MP-W	Mounting bracket
2	50.1330	Square nut M6
3	5070-GM-MAG	Bracket for magnetic sensor
4	1368	Magnet
5	289 Sensor	Reed switch
6	5070-DG-IN-G*	Sensor bracket inductive
7	5070-SG-XS8	Bracket for M8 sensor
8	XS05B1PAL2	M8 inductive sensor-cable
9	XS508B1PAM8	M8 inductive sensor-M8
10	7070-SG-XS12	Bracket for M12 sensor
11	5070-GM-SH	Bracket for switch
12	D3V-166-1C5	Omron switch
13	5070-SD-ME	Bracket for Roll switch
14	5070-SG-SH	Bracket for switch
15	XCMD2117L1	Mechanical switch Roll
16	5070-BB-L	Bracket for endcap mounting
17	5070-HS-50	Bracket for carriage

\* For bracket 6+13 holes need to be drilled.

# LT50-TR-S15(D)

## ACCESSORIES

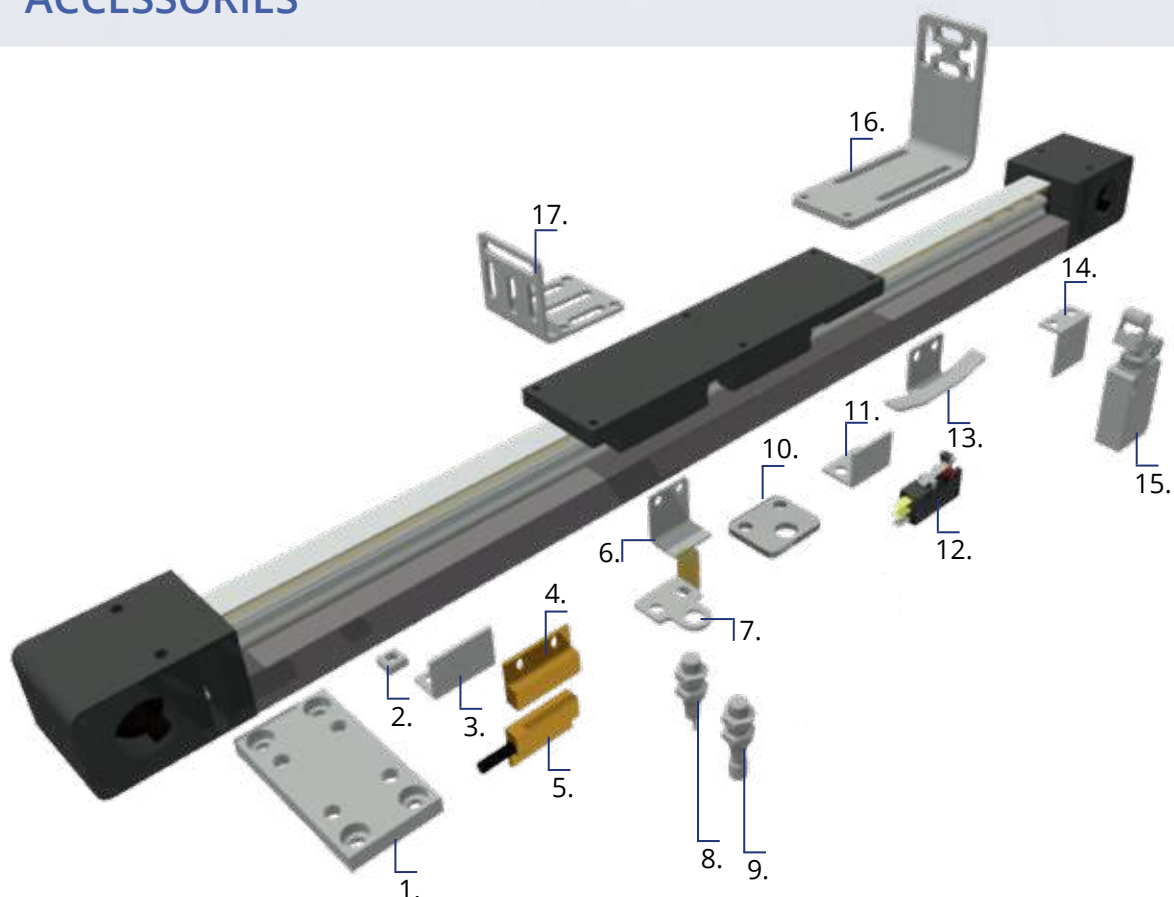

1	5070-MP-W	Mounting bracket
2	50.1330	Square nut M6
3	5070-GM-MAG-S	Bracket for magnetic sensor
4	1368	Magnet
5	289 Sensor	Reed switch
6	5070-DG-IN*	Sensor bracket inductive
7	5070-SG-XS8	Bracket for M8 sensor
8	XS05B1PAL2	M8 inductive sensor-cable
9	XS508B1PAM8	M8 inductive sensor-M8
10	7070-SG-XS12	Bracket for M12 sensor
11	5070-GM-SH-S	Bracket for switch
12	D3V-166-1C5	Omron switch
13	5070-SD-ME*	Bracket for Roll switch
14	5070-SG-SH	Bracket for switch
15	XCMD2117L1	Mechanical switch Roll
16	5070-BB-L	Bracket for endcap mounting
17	5070-HS-50	Bracket for carriage

\* For bracket 6+13 holes need to be drilled.



# LT2 SERIES

Robust linear units with  
wheel- or rail guide



- Compact design, the width of the profile is 60 mm
- Guide system of hardened wheels on hardened shafts or recirculating rail guide, size -20-
- Toothed belt type AT10, 16 mm wide
- Double carriage design for high load
- C8 guide wheel system is very resistant to pollution
- Recirculating ball rail guide for heavy loads

## TECHNICAL DATA\*\*

### LT2-TR-C8

### LT2-TR-D1

### LT2-TR-S20

Maximum stroke*	mm	5.500	5.500	3.000
Maximum speed	mm/s	5.000	5.000	3.000
Maximum acceleration	m/s <sup>2</sup>	50	50	30
No load torque	Nm	0,2	0,2	0,6
Max. driving torque	Nm	34	34	34
Repeatability	mm	± 0,1	± 0,1	± 0,1
Movement per revolution	mm	180	180	180

\* longer lengths on request

\*\*The values shown are theoretical maximum ratings. A suitable safety factor should always be applied based on application requirements.

# LT2 SERIES

## TECHNICAL DATA

### Load capacity

		LT2-TR-C8	LT2-TR-D1-C8R	LT2-TR-D1-C10	LT2-TR-S20	LT2-TR-S20D
Mx	Nm	5	40	62	165	726
My	Nm	6	82	106	310	726
Mz	Nm	7	22	26	165	330
Fx	N	2.100	2.100	2.100	2.100	2.100
Fy	N	1.000	2.400	2.600	4.500	9.000
Fz	N	1.000	2.400	2.600	4.500	9.000

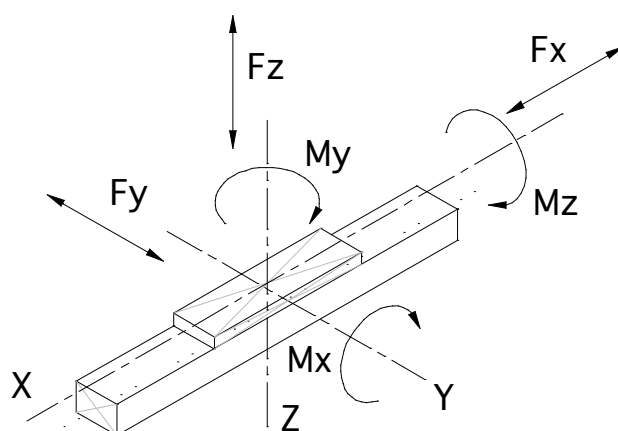

## MOMENT OF INERTIA (NMM<sup>2</sup>)

	LT50-TR-G8	LT50-TR-S15
Elx	2,169*10 <sup>10</sup>	1,545*10 <sup>10</sup>
Ely	2,230*10 <sup>10</sup>	1,524*10 <sup>10</sup>

## WEIGHTS (KG)

	LT2-TR-C8	LT2-TR-D1-C8R	LT2-TR-D1-C10	LT2-TR-S20	LT2-TR-S20D
Unit 0 mm stroke	4,31	4,90	5,00	4,80	5,31
Weight per 100 mm stroke	0,34	0,40	0,50	0,40	0,40
Mass of carriage	0,65	1,20	1,25	0,84	0,99

# LT2 SERIES

## DIMENSIONS

### DIMENSIONS LT2-TR-C8

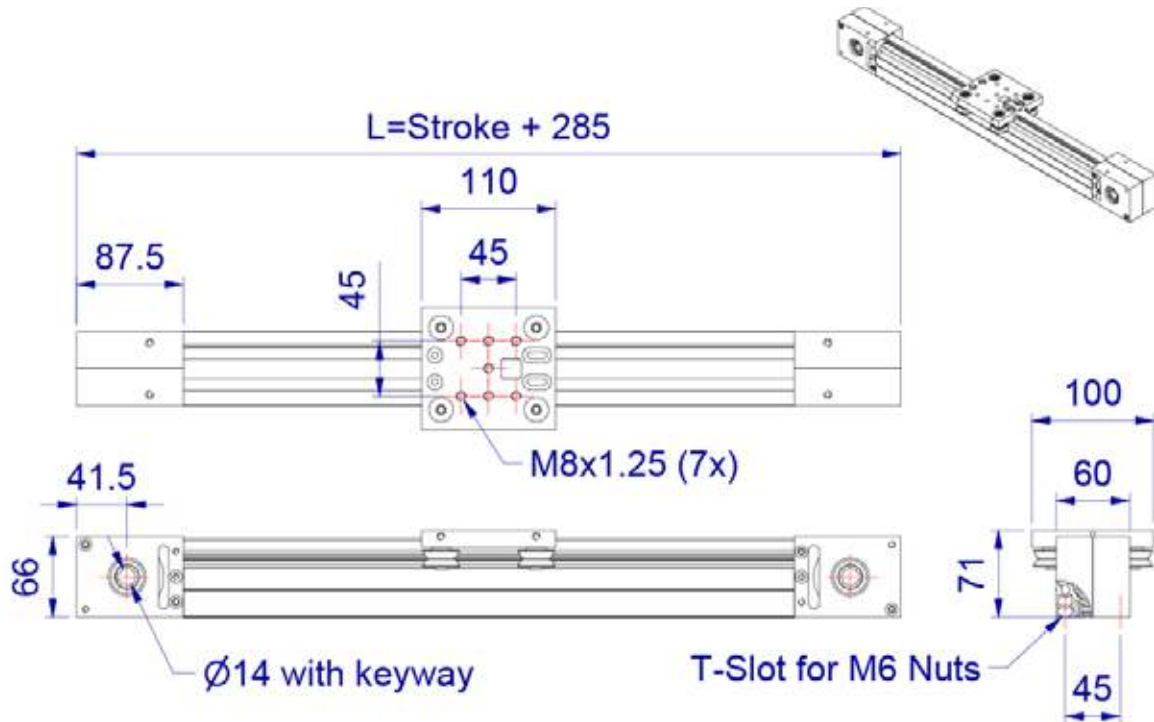

### DIMENSIONS LT2-TR-S20 / LT2-TR-S20-D\*

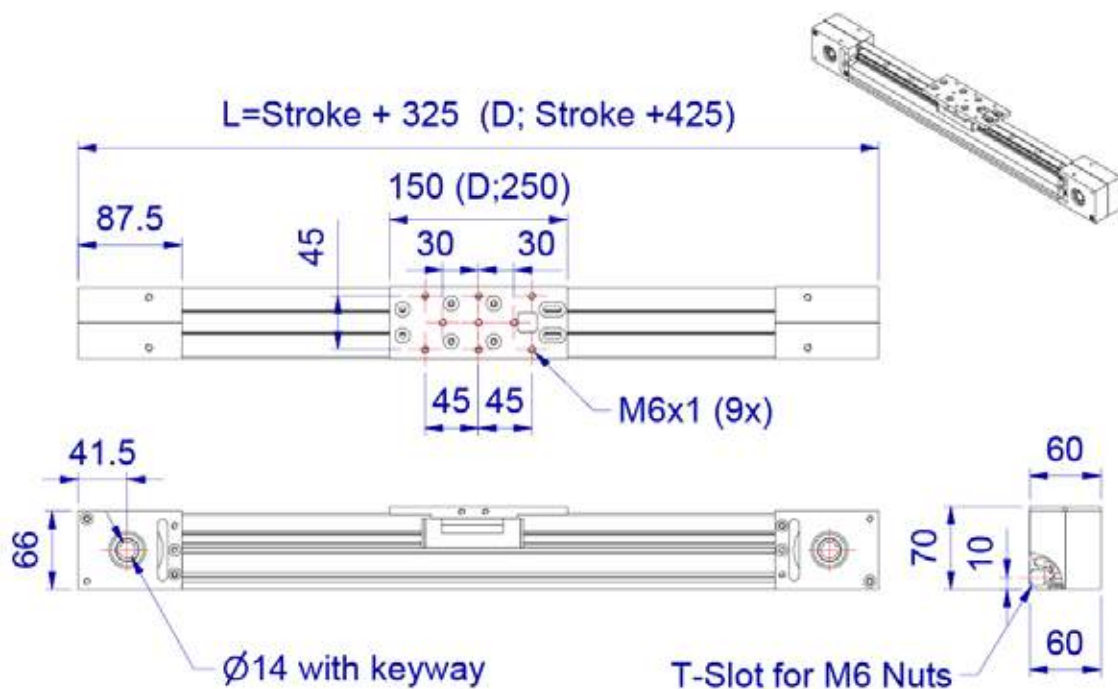

# LT2 SERIES

## DIMENSIONS

### DIMENSIONS LT2-TR-D1-C8R

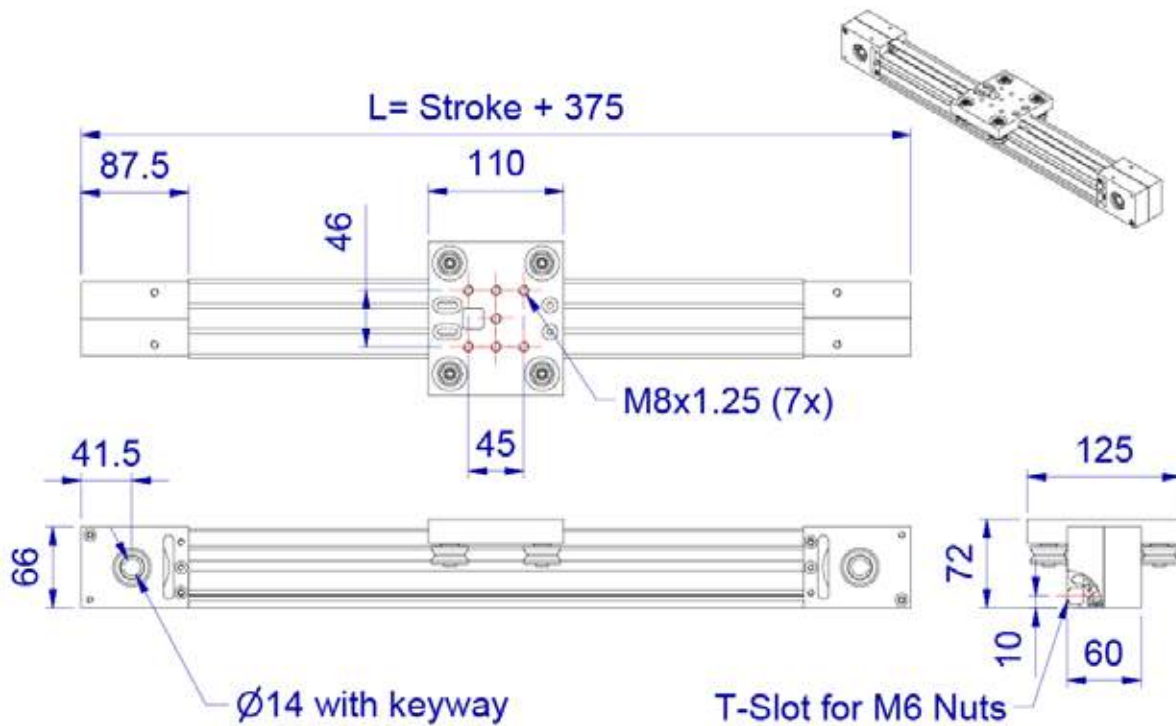

### DIMENSIONS LT2-TR-D1-C10

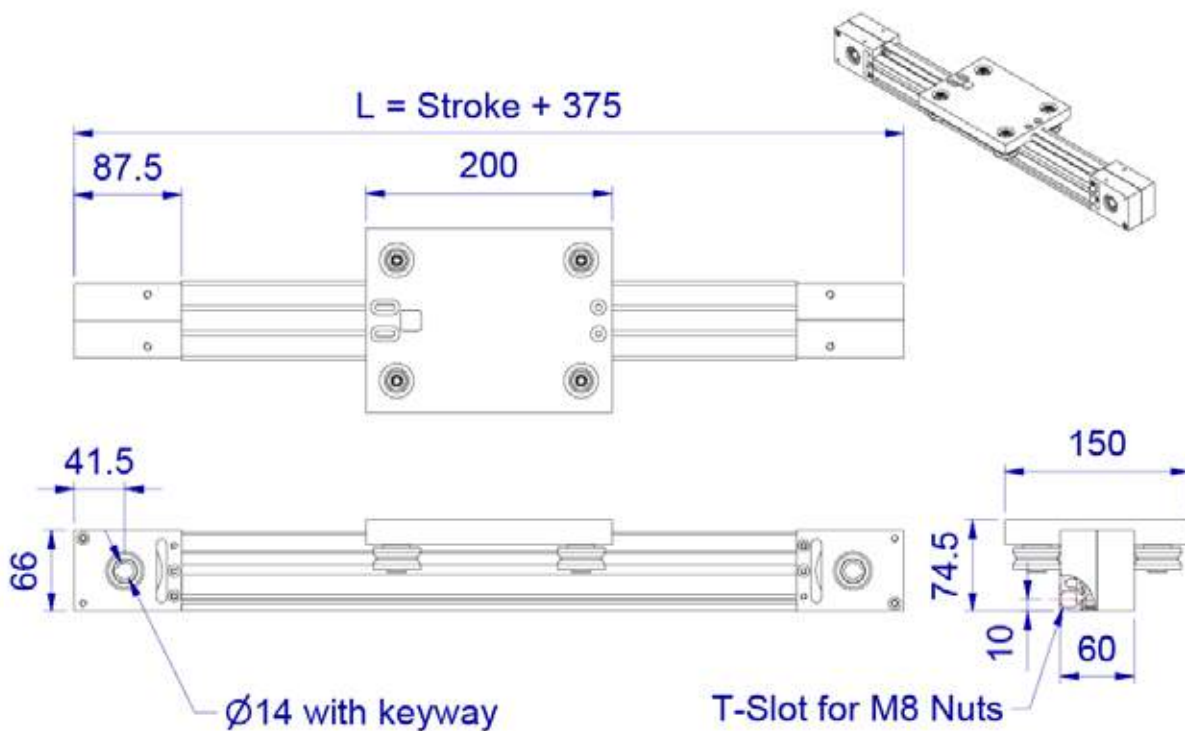

# LT2 SERIES

## ACCESSOIRES

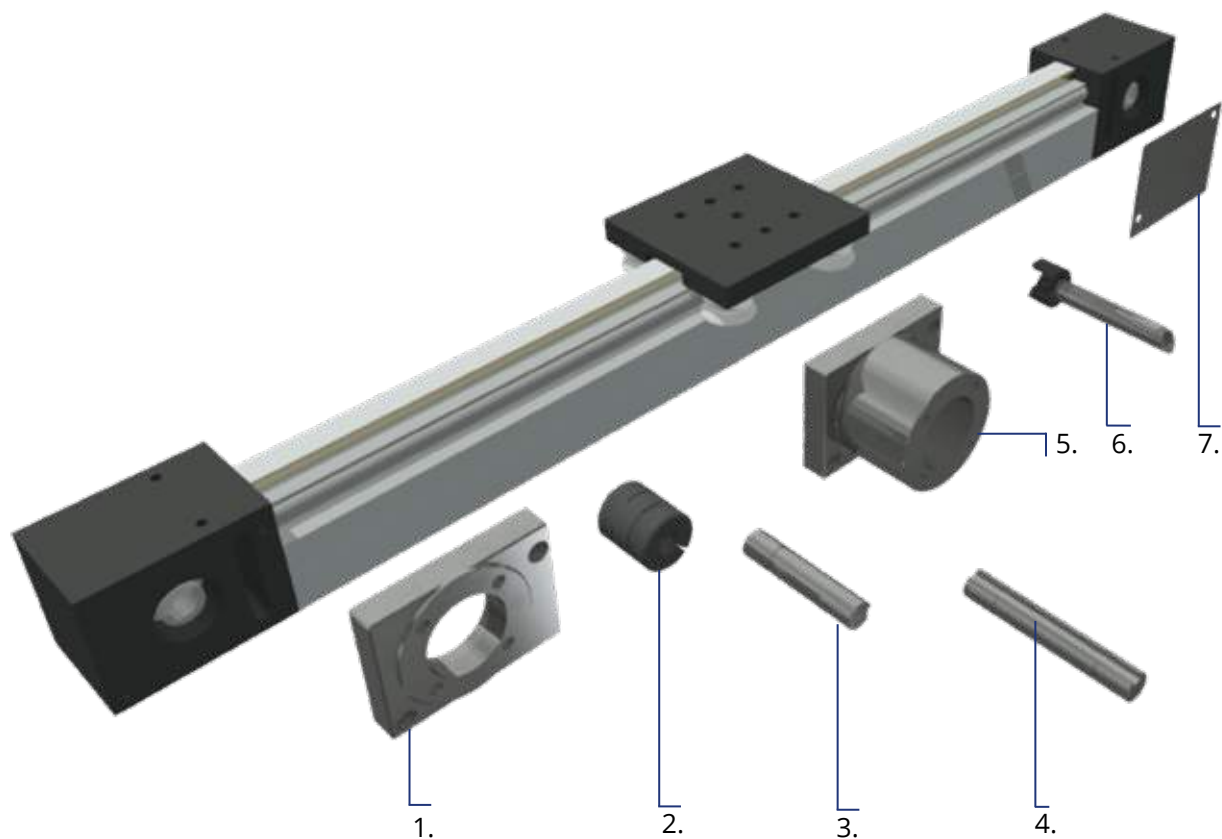

1	7070-T-XXX	Motor flange
2	Rotex GS14	Flexible coupling
3	7070-SH-14	Motor shaft 1 side
4	7070-SH-14D	Motor shaft 2 sides
5	7070-FL-XX	Motor adapter
6	7070-VA-14-XXX	Coupling shaft
7	7070-BP	Blanking cover plate

# LT2-TR-C8

## ACCESSORIES

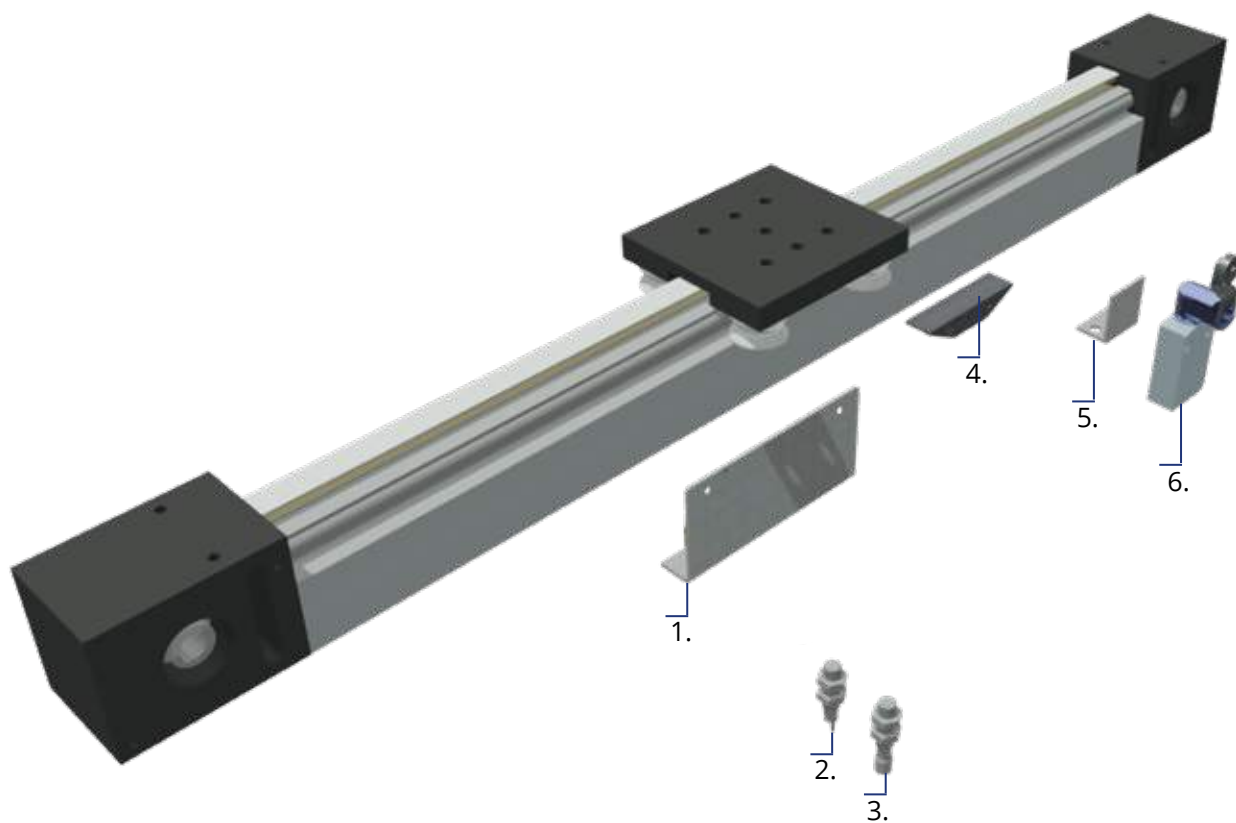

1	7070-DG8-IN	Sensor bracket
2	XS05B1PAL2	M8 inductive sensor-cable
3	XS508B1PAM8	M8 inductive sensor-M8
4	7070-SG-ME	Bracket for roll switch
5	7070-SA-SH	Bracket for switch
6	XCMD2117L1	Mechanical switch roll

# LT2-TR-S20(D)

## ACCESSORIES

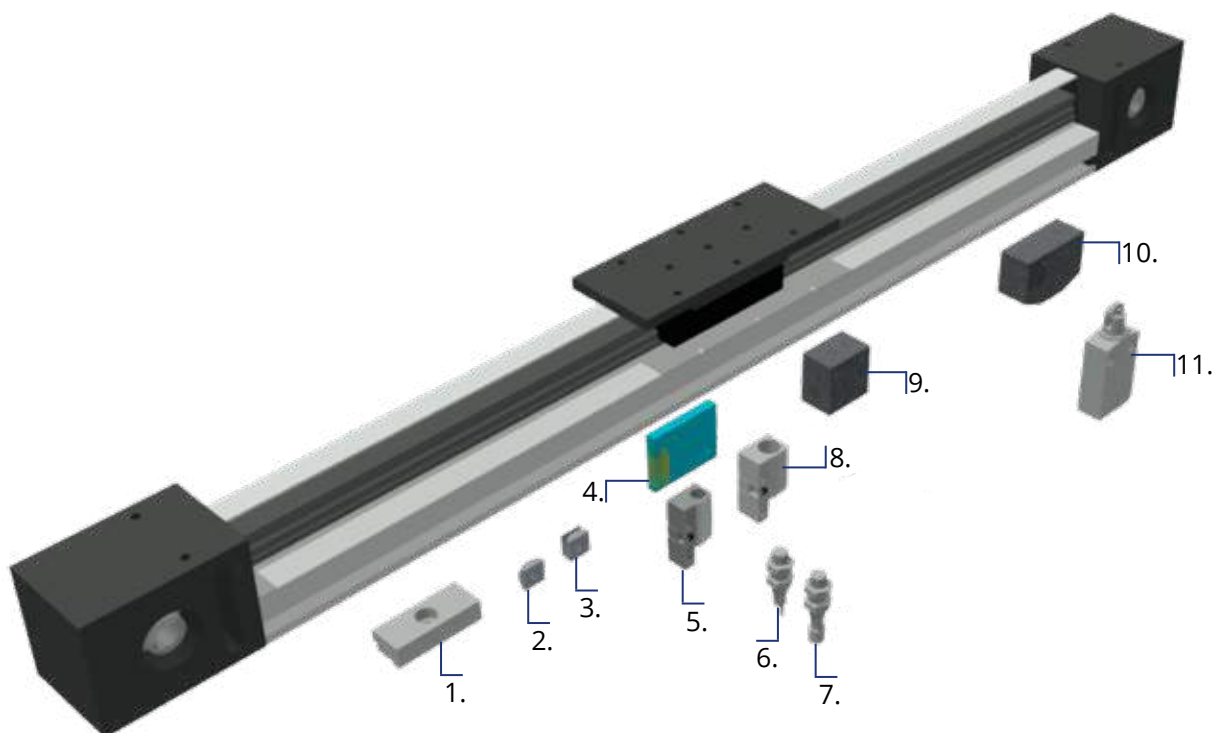

1	70121	Clamping bracket
2	21.1347	Square nut M5
2	21.1330	Square nut M6
2	21.1351	Square nut M8
3	21.1347F	Square nut with Fix M5
3	21.1330F	Square nut with Fix M6
3	21.1351F	Square nut with Fix M8
4	7070-SH-XS	Bracket for Telem. bracket
5	XSZB108	Bracket for M8 sensor
6	XS05B1PAL2	M8 inductive sensor-cable
7	XS508B1PAM8	M8 inductive sensor-M8
8	XSZB112	Bracket for M12 sensor
9	7070-DB4-IN	Sensor bracket
10	7070-SD-ME	Switch bracket
11	XCMD2102L	Switch with roll



# LTY SERIES

Linear units with toothed belt drive and double rail guide system

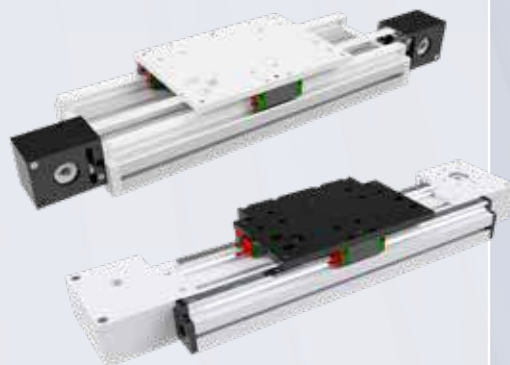

- Basic extrusion profile 45 x 135 or 45 x 180 mm
- Rail Guide system size -20- with 3 or 4 LM blocks
- Very heavy load capacity
- Toothed belt type AT10, 16 or 25 mm wide

## Technical data\*

## LTY series

Maximum stroke length	mm	12.000
Maximum speed	mm/s	3.000
Maximum acceleration	m/s <sup>2</sup>	30
Max. driving torque	Nm	34
Repeatability	mm	± 0,1
Movement per revolution	mm	200

\*The values shown are theoretical maximum ratings. A suitable safety factor should always be applied based on application requirements.

# LTY SERIES

## TECHNICAL DATA\*

LOAD CAPACITY		LTY135	LTY180
Mx	Nm	1.600	1.600
My	Nm	1.780	1.900
Mz	Nm	1.250	1.250
Fx	N	2.100	2.100
Fy	N	14.800	14.800
Fz	N	14.800	14.800

\*Please ask us for specific calculations of the guide system.

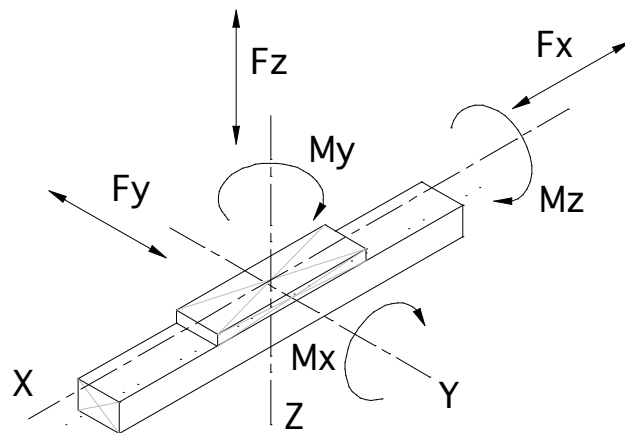

## MOMENT OF INERTIA (NMM<sup>2</sup>)

	LTY135	LTY180
Elx	7,046*10 <sup>10</sup>	8,586*10 <sup>10</sup>
Ely	3,759*10 <sup>10</sup>	8,505*10 <sup>10</sup>

## WEIGHTS (KG)

	LTY135	LTY180
Unit weight 0 mm stroke	6,45	7,26
Weight per 100 mm stroke	1,05	1,23
Mass of carriage	0,90	1,20

# LTY SERIES

## DIMENSIONS

### DIMENSIONS LTY135-TR-S20T-D1

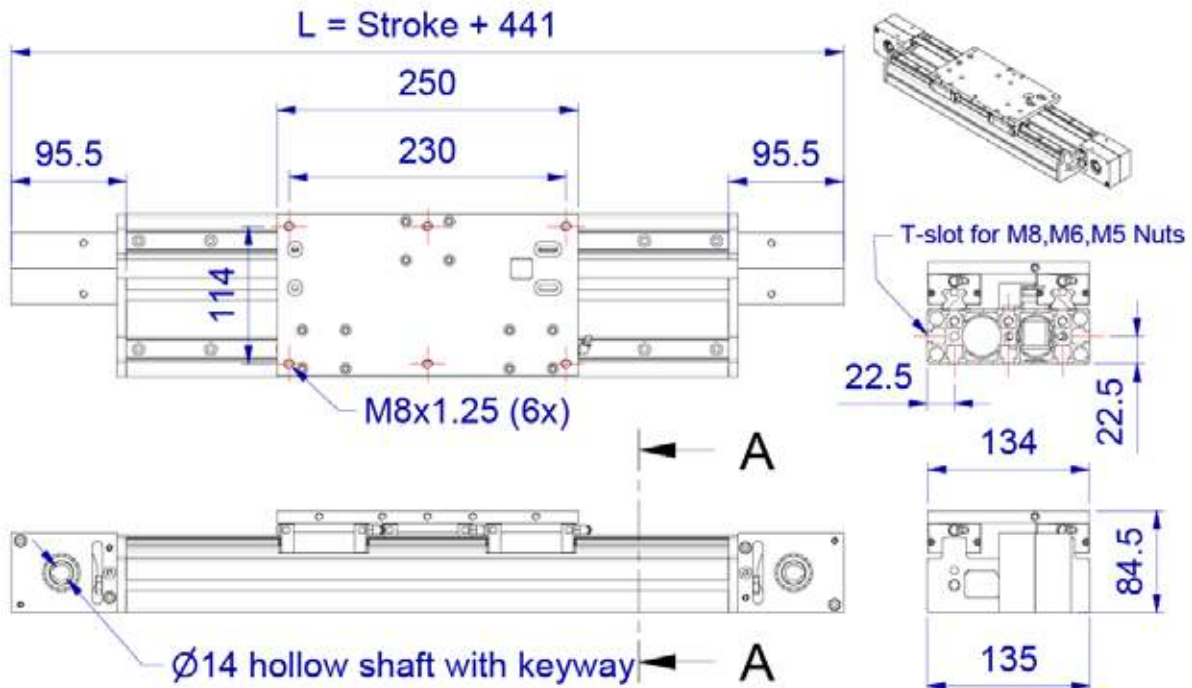

### DIMENSIONS LTY135-TR-S20T-S1

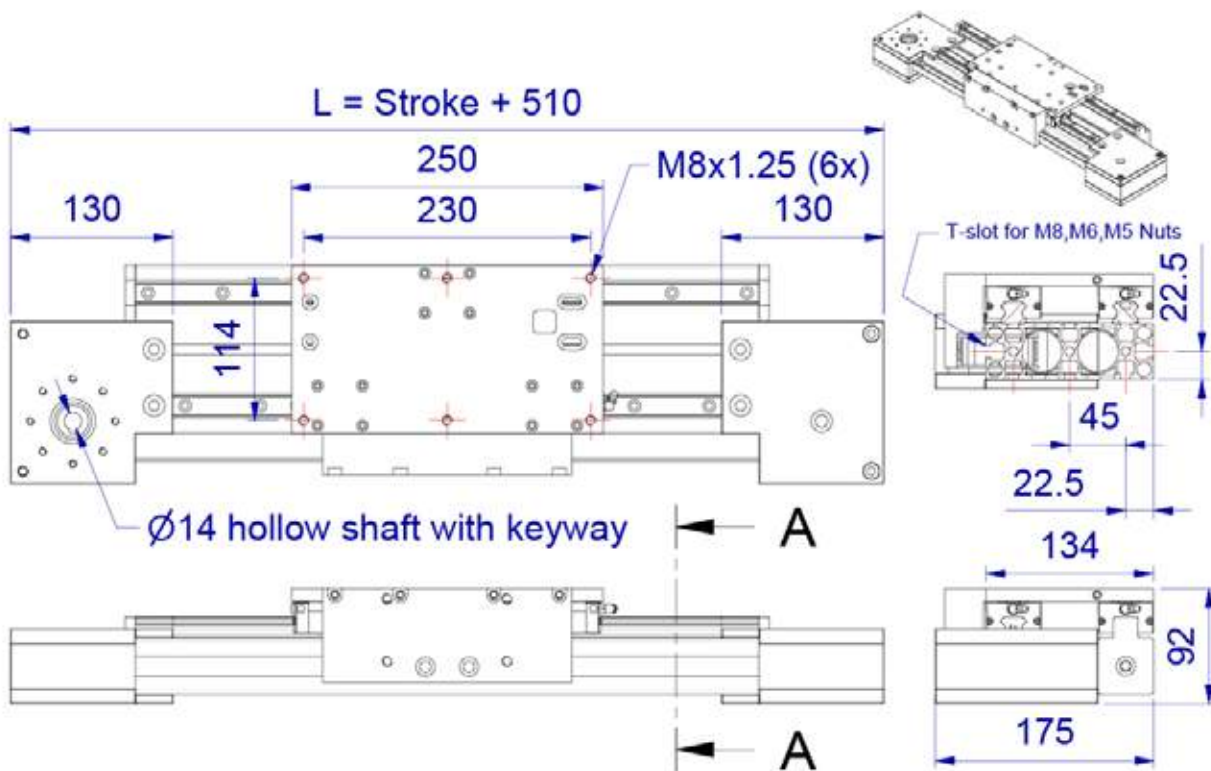

# LTY SERIES

## DIMENSIONS

### DIMENSIONS LTY180-TR-S20T-D1

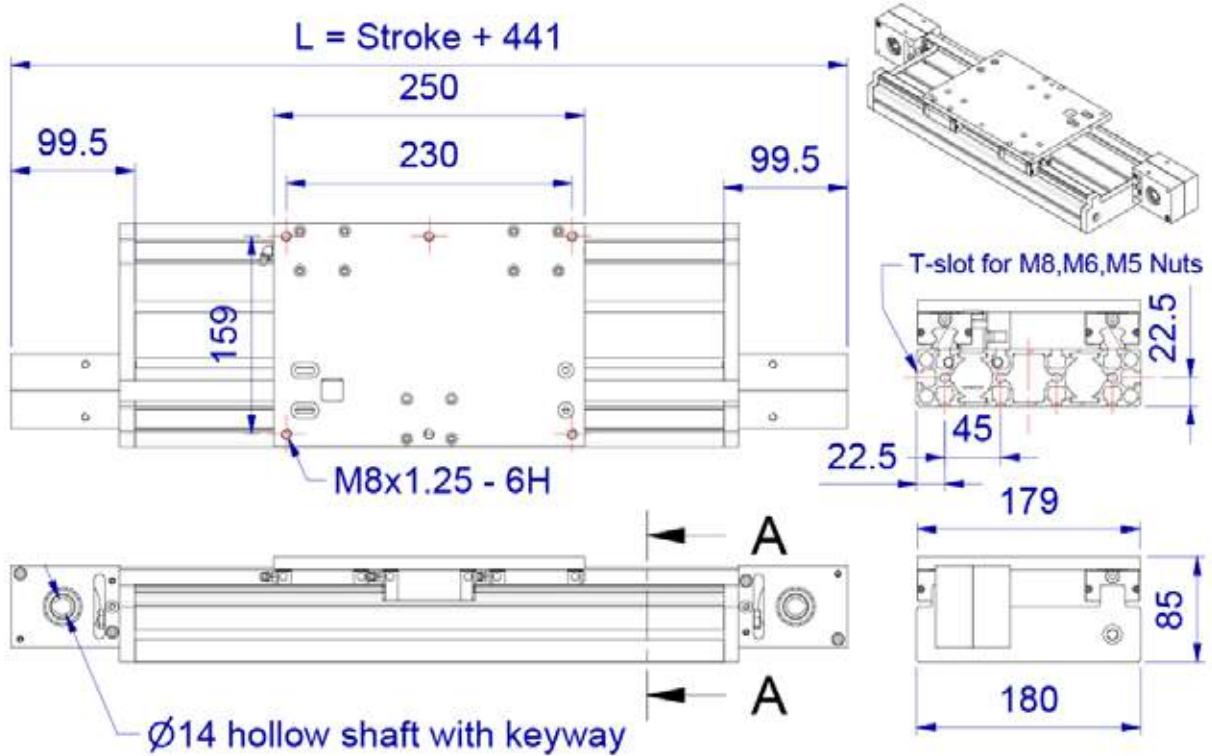

### DIMENSIONS LTY180-TR-S20T-S1

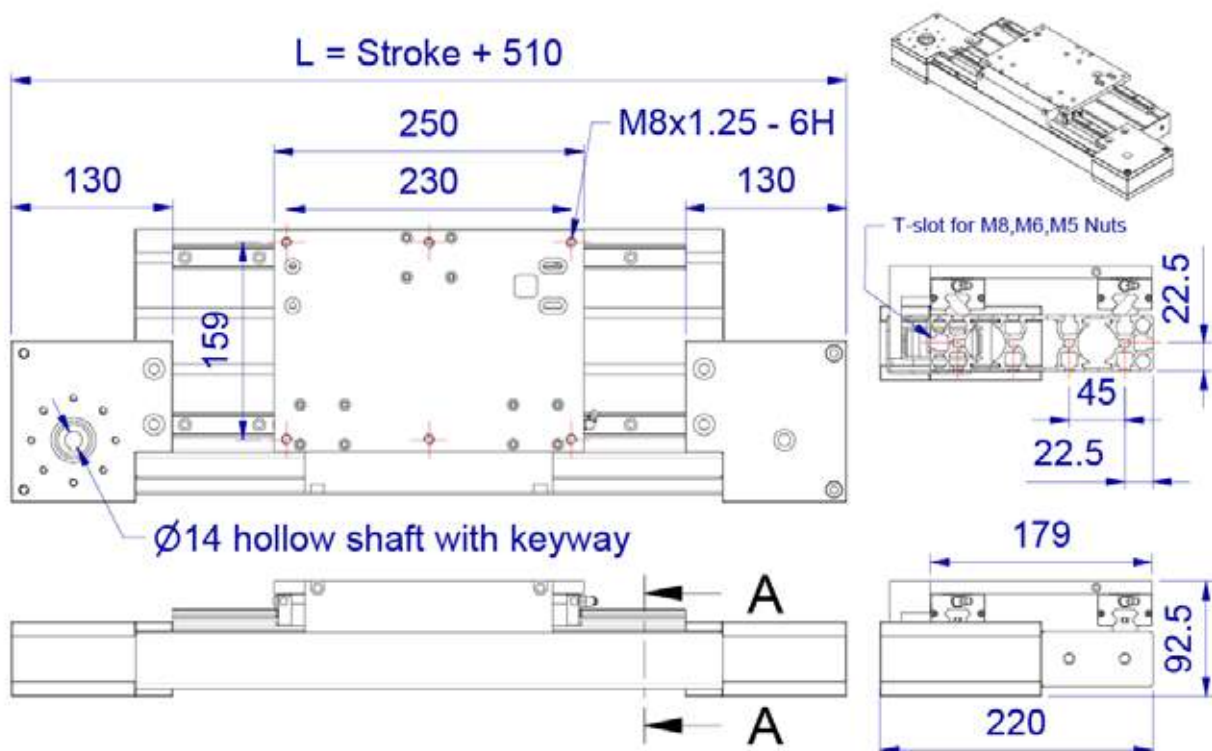

# INTERNAL GUIDE UNITS, STRUCTURAL DESIGN

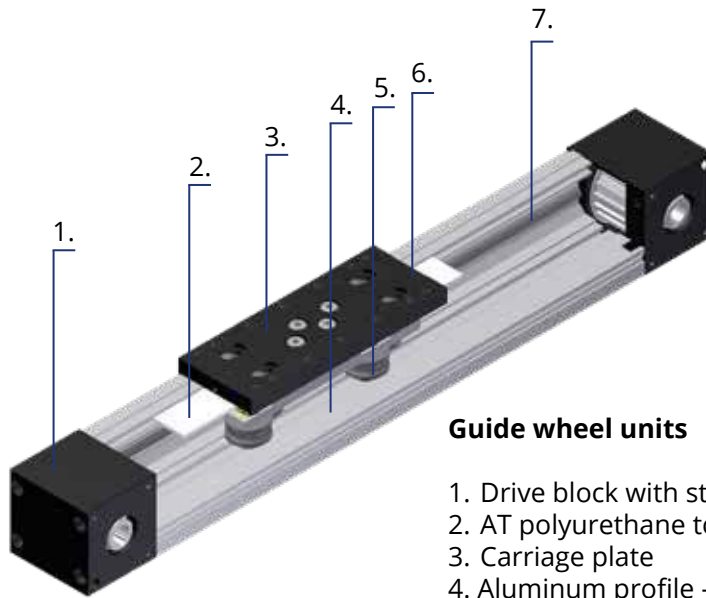

## Guide wheel units

1. Drive block with steel pulley
2. AT polyurethane toothed belt with steel cords
3. Carriage plate
4. Aluminum profile - anodized
5. Guide wheel
6. Belt clamp with belt tensioning system
7. Two hardened steel shafts (60 HCR)

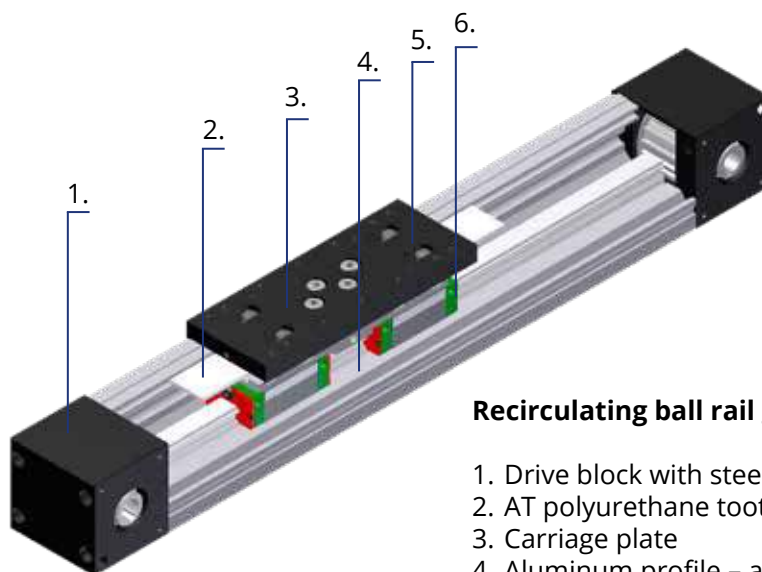

## Recirculating ball rail guide units

1. Drive block with steel pulley
2. AT polyurethane toothed belt with steel cords
3. Carriage plate
4. Aluminum profile - anodized
5. Belt clamp with belt tensioning system
6. Linear ball guide

# CHARACTERISTICS

The LT55, LT60S and LT80(S) series are linear units with a toothed belt drive and compact dimensions that provide high load capacities, high-speed, accuracy and repeatability. These linear units can also be combined with various multi-axis systems.

An accurate extruded aluminum anodized profile with an integrated recirculating ball rail system or guide wheels enables high load capacity and optimum movement for large loads at high speed. The guide wheels make the LT80 ideal for very high speeds up to 10 m/s. The aluminum profile contains T-slots for mounting and proximity switch fixing. Also a T-slot suitable for reed switches. An internal magnet is provided with the LT55 and LT80. The linear units LT55 and LT80 use a AT5 or AT10 polyurethane tooth belt with steel tension cords. This "proposition" belt is used together with a zero-backlash pulley to achieve a high precision and high load capacity. The belt also has the function of protecting the internal parts against dust. It also prevents reaching the guide from the outside.

The carriage can be produced in a custom length with extra fixing holes according to customer wishes. Also available with pre-designed adapters for attachment of the motor and gearbox.

**LT55**

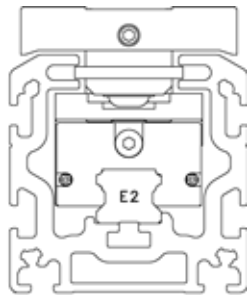

**LT60S**

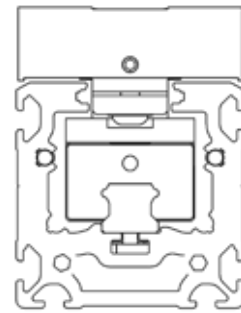

**LT80**

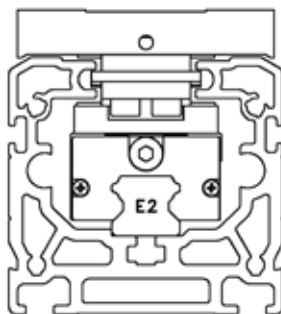

**LT80S**



**LTY200**

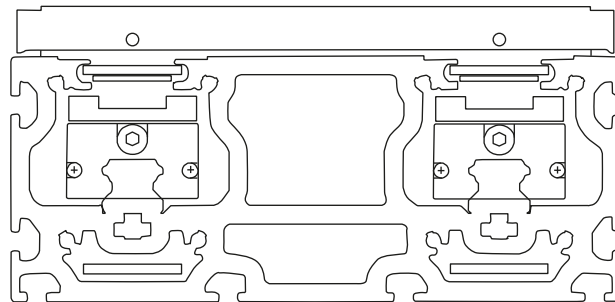

# LT55 SERIES

Compact linear units  
with internal rail guide



- Compact design, the width of the profile 55 mm
- Internal recirculating ball rail guide size -15 -
- Double carriage design for heavier loads
- Toothed belt type 25 AT5
- Advanced internal lubrication system

## TECHNICAL DATA\*\*

## LT55-TR-S15D

Maximum stroke length	mm	5.750
Maximum speed	mm/s	3.000*
Maximum acceleration	m/s <sup>2</sup>	30
No load torque	Nm	0,6
Max. driving torque	Nm	14
Repeatability	mm	± 0,1
Movement per revolution	mm	150

\*Depending on model linear guide

\*\*The values shown are theoretical maximum ratings. A suitable safety factor should always be applied based on application requirements.

# LT55 SERIES

## TECHNICAL DATA

### LOAD CAPACITY LT55-TR-S15D

Mx	Nm	106
My	Nm	106
Mz	Nm	40
Fx	N	1.200
Fy	N	3.400
Fz	N	3.600

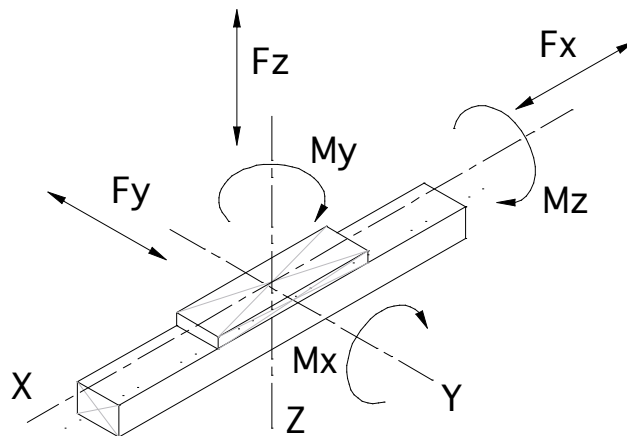

## MOMENT OF INERTIA (NMM<sup>2</sup>)

### LT55-TR-S15D

Elx	1,520*10 <sup>10</sup>
Ely	1,955*10 <sup>10</sup>

## WEIGHTS (KG)

### LT55-TR-S15D

Unit weight 0 mm stroke	3,69
Weight per 100 mm stroke	0,40
Mass of carriage	0,97

# LT55 SERIES

## DIMENSIONS

### DIMENSIONS LT55-TR-S15D

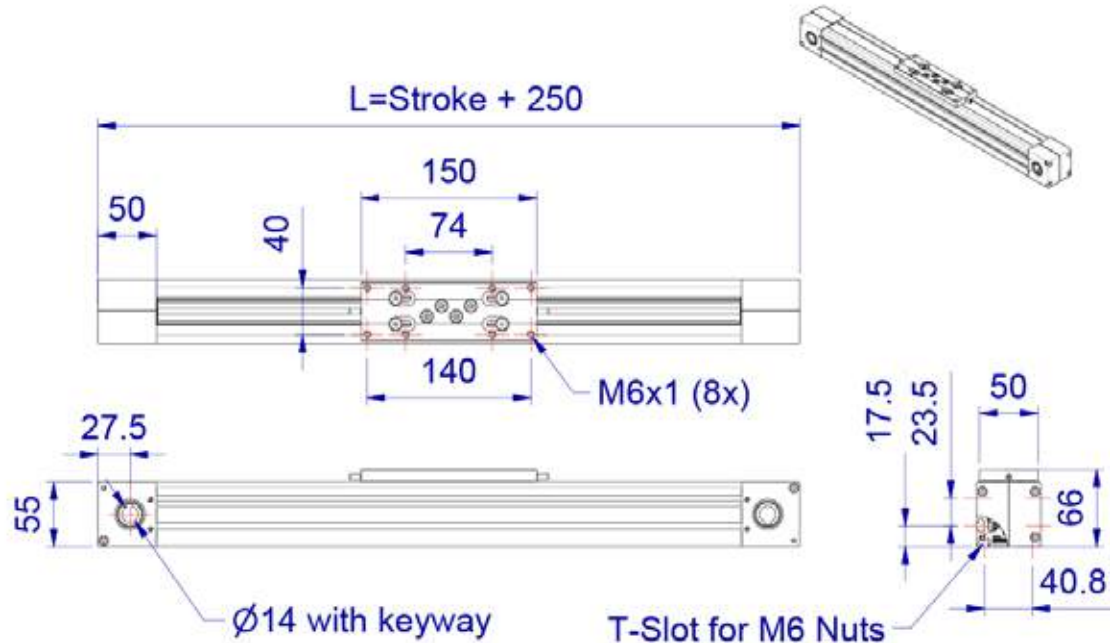

### CLAMPING DIMENSIONS

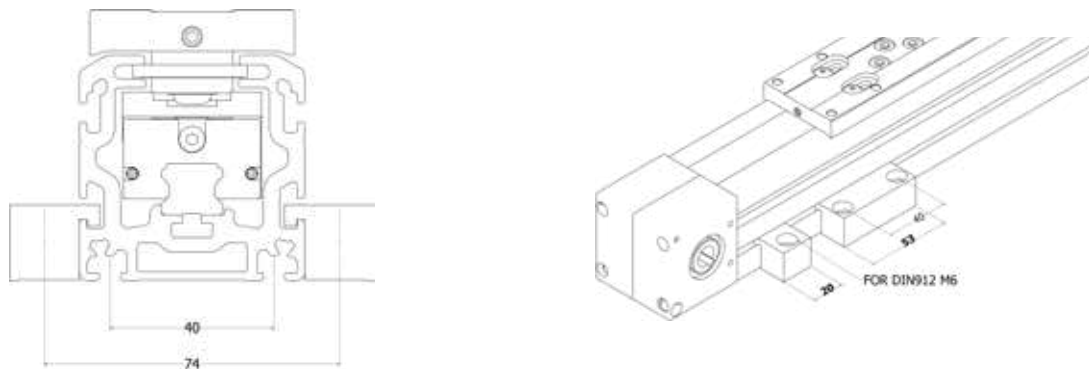

### DIMENSIONS FOR MOUNTING

### DIMENSIONS FOR MOTOR ATTACHEMENT

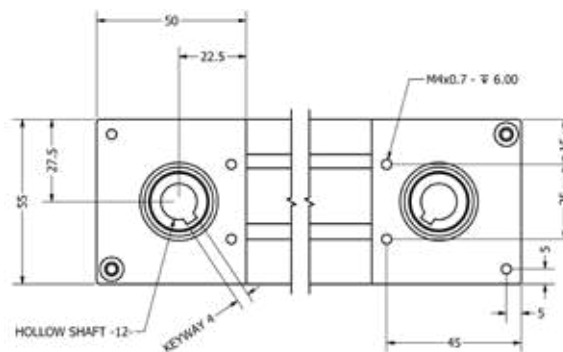
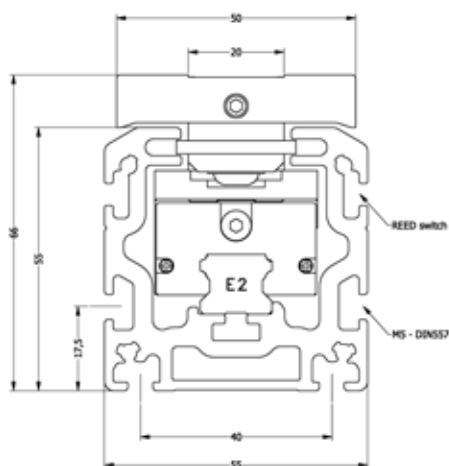

# LT55 SERIES

## MOTOR ACCESSORIES

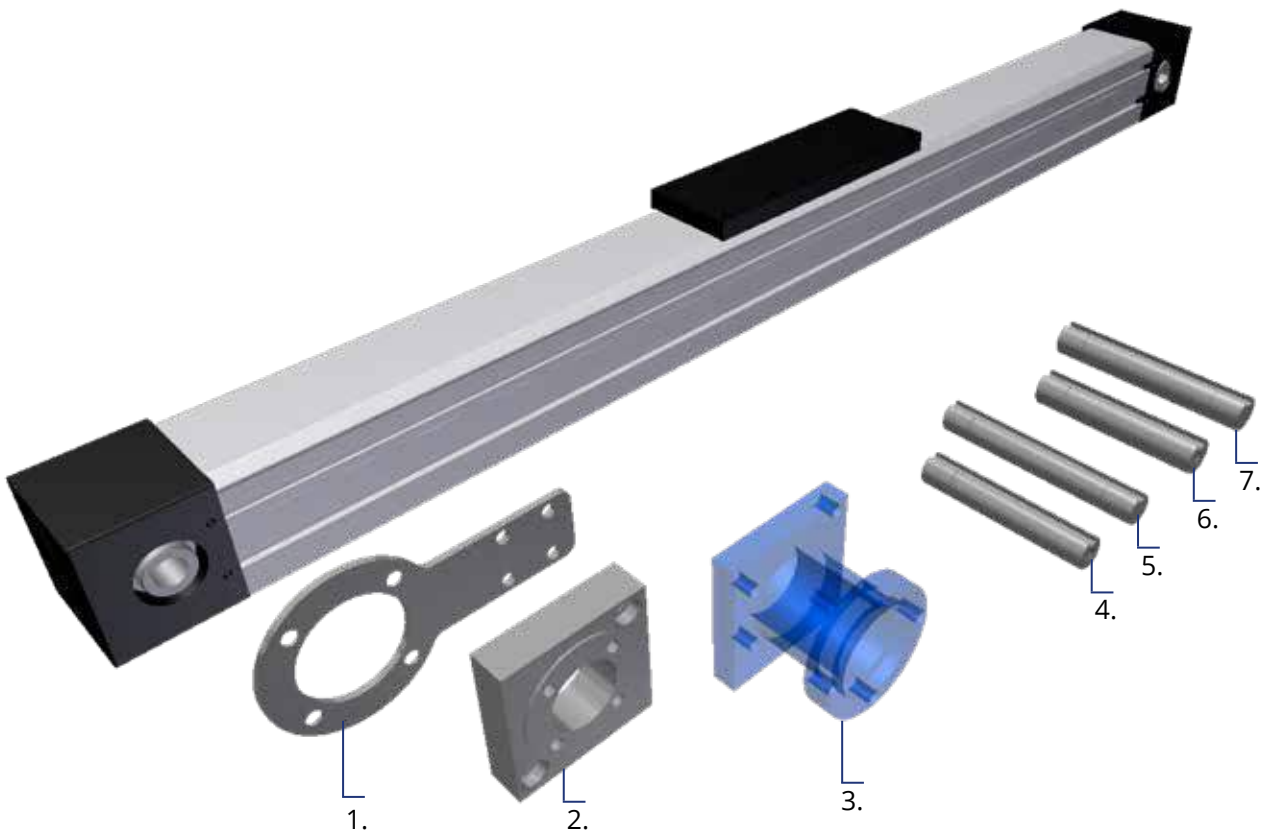

1	5570-RA-M-XXX	Motor adaptor armtype
2	5570-F-XXX	Motor Flange
3	5570-FL-XXX	Motor adaptor
4	5070-SS-12-GS14	Single shaft ø12
5	5070-DS-12-GS14	Double shaft ø12
6	5070-SS-14-GS14	Single shaft ø14
7	5070-DS-14-GS14	Double shaft ø14

# LT55-TR-S15D

## ACCESSORIES

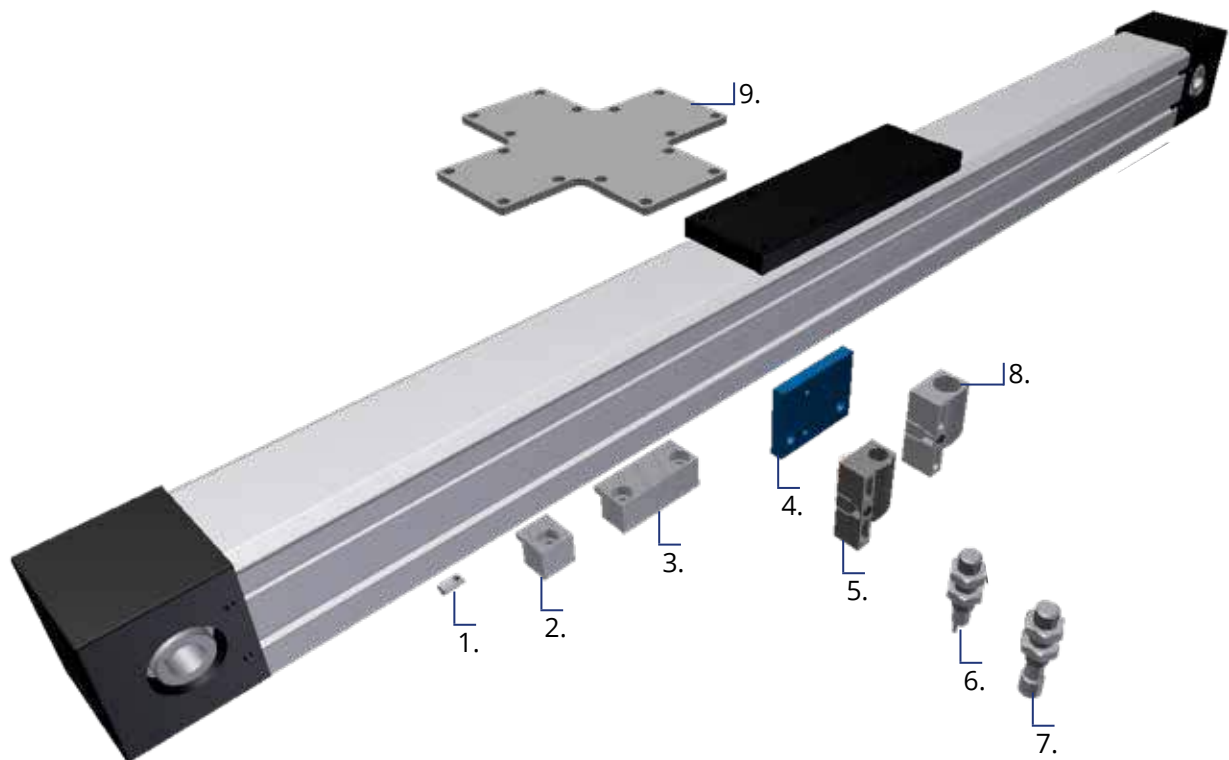

1	111-012	Nut M5
2	55121	Clamping plate single
3	55122	Clamping plate double
4	7070-SH-XS	Bracket for Telem. bracket
5	XSZB108	Bracket for M8 sensor
6	XS05B1PAL2	M8 inductive sensor-cable
7	XS508B1PAM8	M8 inductive sensor-M8
8	XSZB112	Bracket for M12 sensor
9	5570-XP-D	X-Cross-bracket

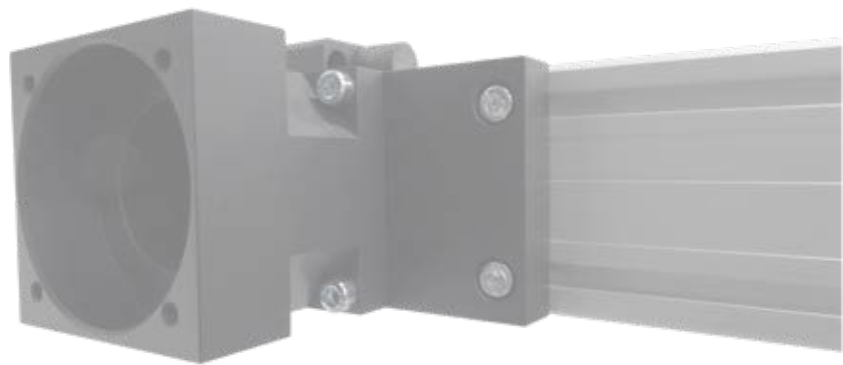

# LT60S SERIES

Compact linear units  
with internal rail guide

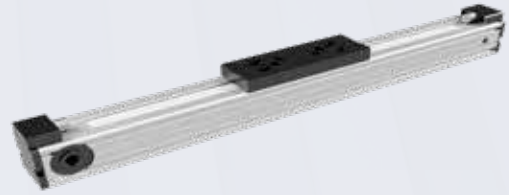

- Compact design, the width of the profile 60 mm
- Internal recirculating ball rail guide size -15 -
- Double carriage design for heavier loads
- Toothed belt type 25 AT5
- Advanced internal lubrication system

## TECHNICAL DATA\*

## LT60STR-S15D

Maximum stroke length	mm	5.750
Maximum speed	mm/s	3.000
Maximum acceleration	m/s <sup>2</sup>	30
No load torque	Nm	0,6
Max. driving torque	Nm	14
Repeatability	mm	± 0,1
Movement per revolution	mm	150

\*The values shown are theoretical maximum ratings. A suitable safety factor should always be applied based on application requirements.

# LT60S-TR-S15D

## TECHNICAL DATA

LOAD CAPACITY		LT60S-TR-S15D	LT60S-TR-S15D****L
Mx	Nm	128	172
My	Nm	128	172
Mz	Nm	40	40
Fx	N	1.200	1.200
Fy	N	3.400	3.400
Fz	N	3.600	3.600

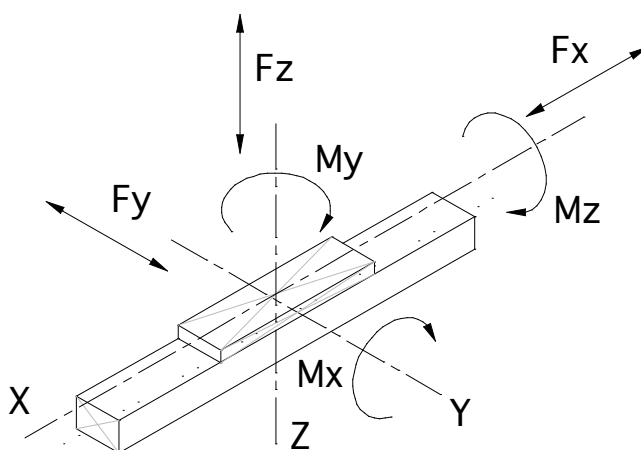

## MOMENT OF INERTIA (NMM<sup>2</sup>)

LT60S-TR-S15D	
Elx	2,489*10 <sup>10</sup>
Ely	3,246*10 <sup>10</sup>

## WEIGHTS (KG)

	LT60S-TR-S15D	LT60S-TR-S15D****L
Unit weight 0 mm stroke	3,69	4,09
Weight per 100 mm stroke	0,40	0,40
Mass of carriage	0,98	1,38

# LT60S-TR-S15D

## DIMENSIONS

### DIMENSIONS LT60S-TR-S15D

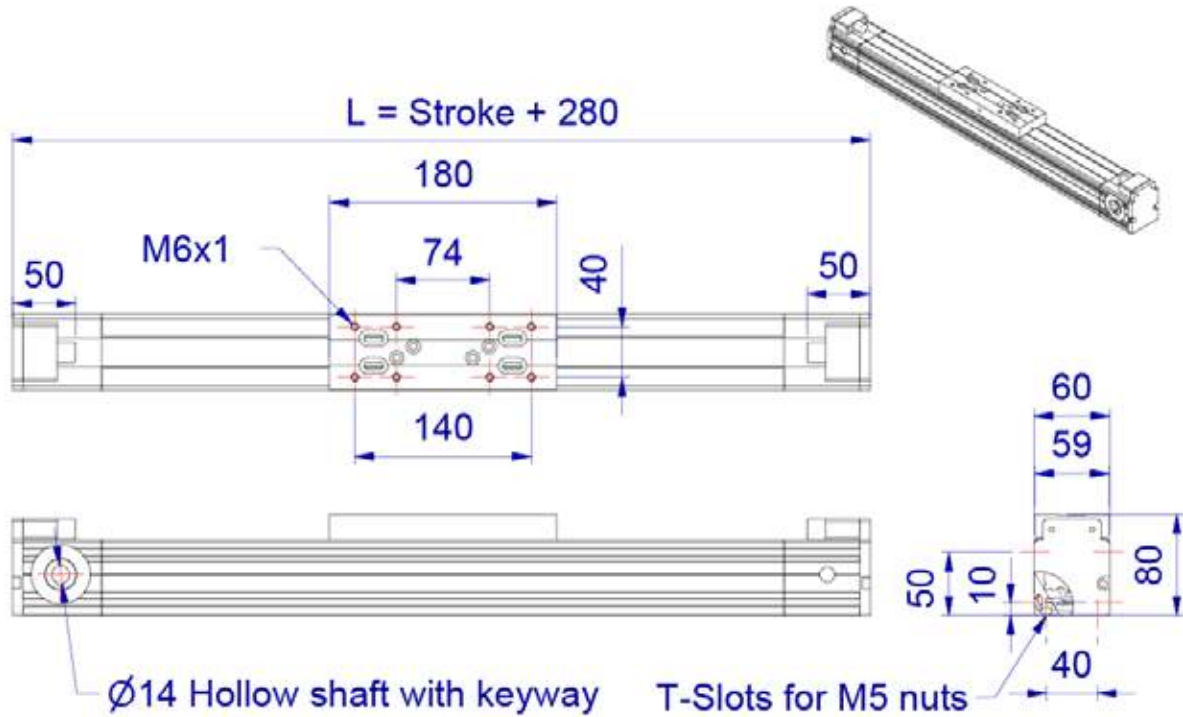

### DIMENSIONS LT60S-TR-S15D-\*\*\*\*L

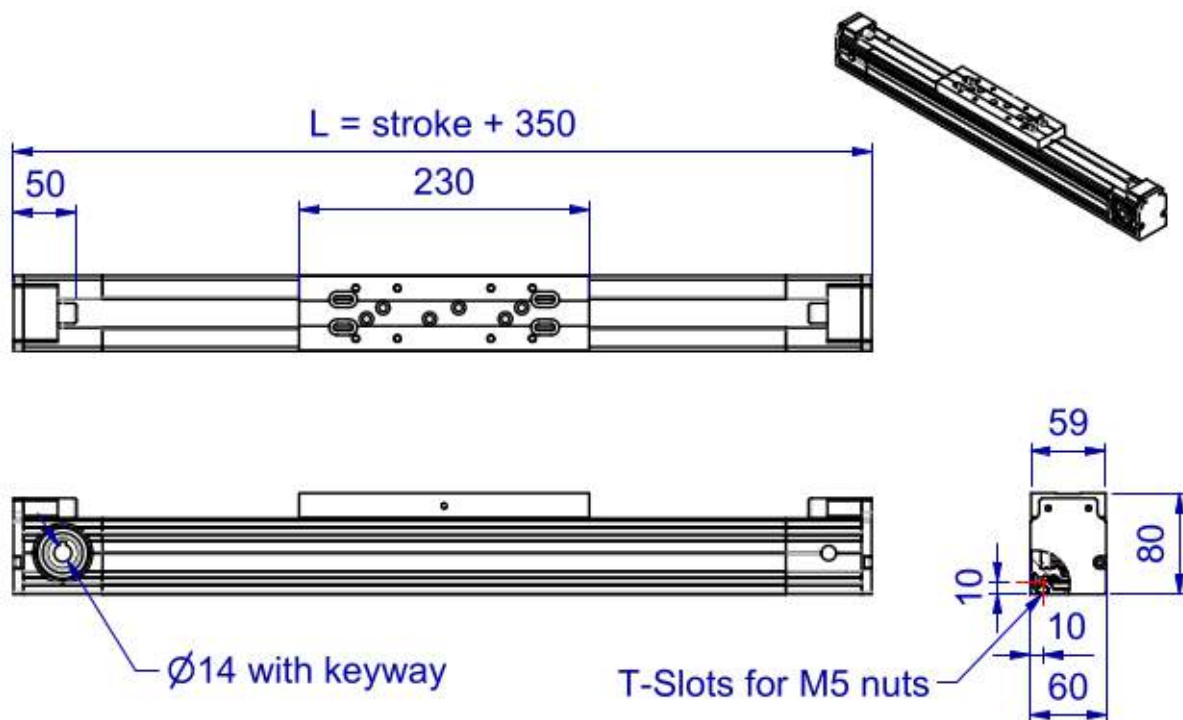

# LT60S-TR-S15D

## DIMENSIONS

### DIMENSIONS FOR MOUNTING

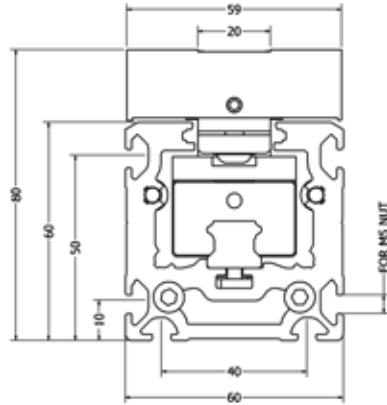

### CLAMPING DIMENSIONS

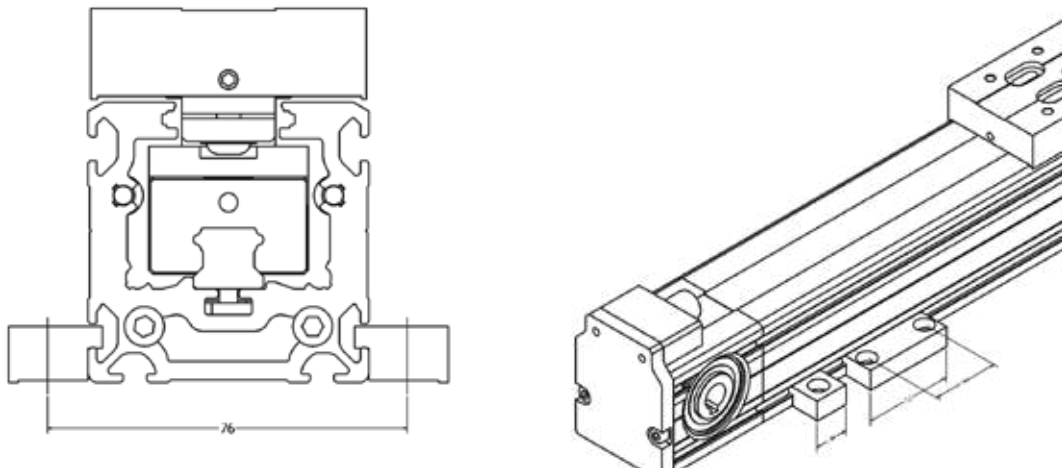

### DIMENSIONS FOR MOTOR ATTACHEMENT

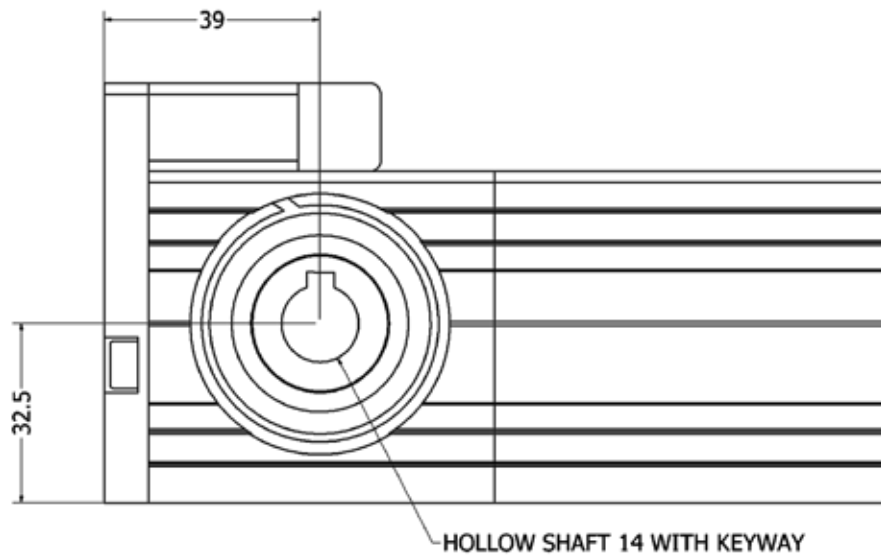

# LT60S-TR-S15D

## MOTOR ACCESSORIES

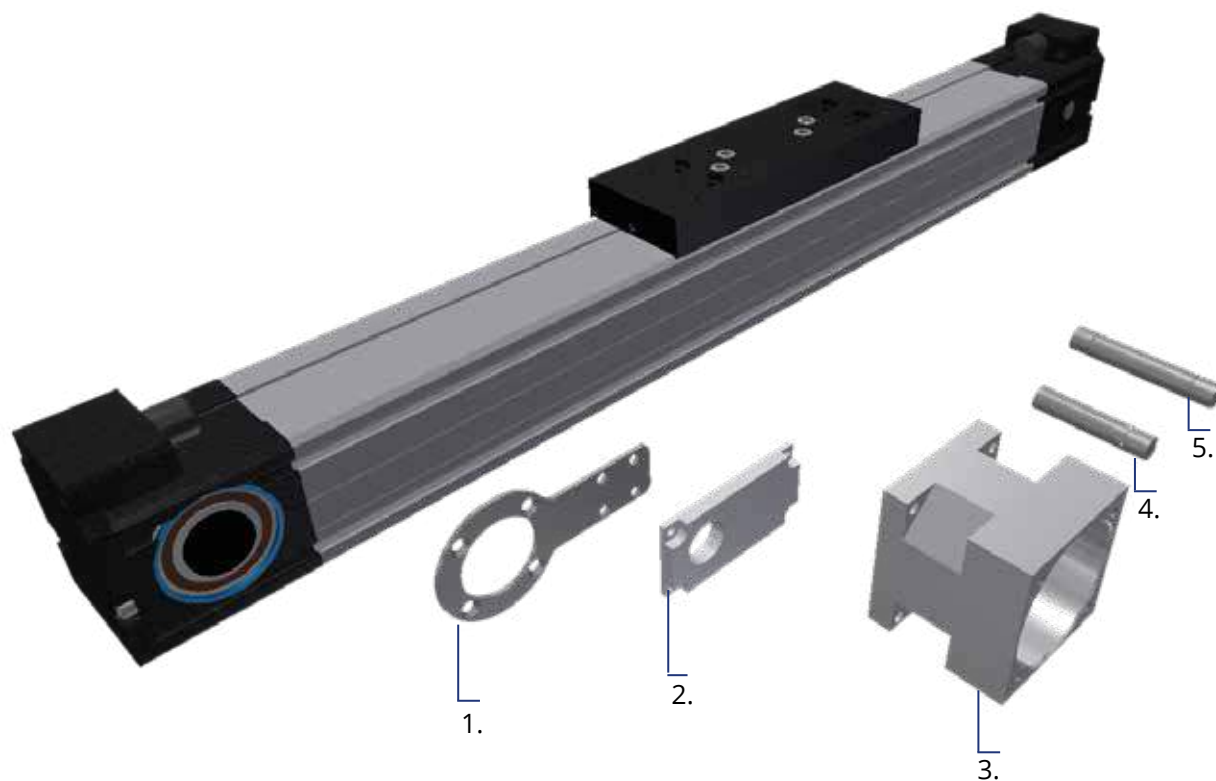

1	60S70-RA-M-XXX	Motor adaptor armtype
2	60S70-F-XXX	Motor Flange
3	60S70-FL-XXX	Motor adaptor
4	60S70-SS-16-GS19	Single shaft $\varnothing$ 16
5	60S70-DS-16-GS19	Double shaft $\varnothing$ 16

# LT60S-TR-S15D

## ACCESSORIES

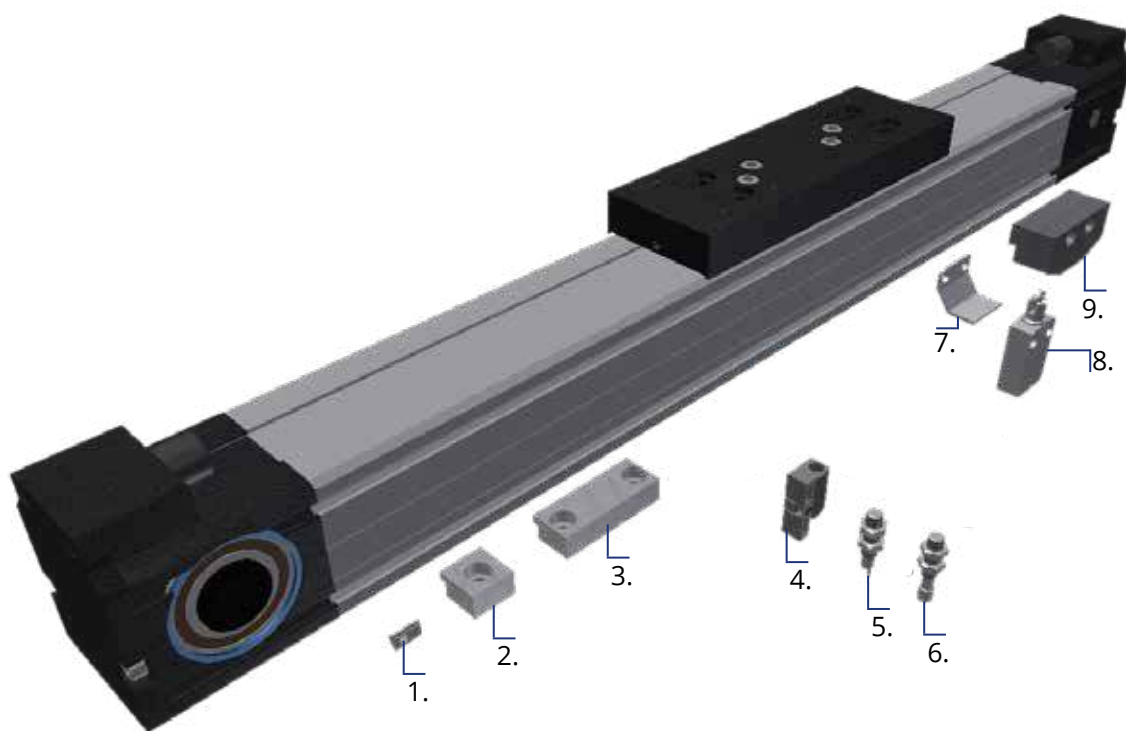

1	111-012	Singel Nut M5
2	60S121	Clamping plate single
3	60S122	Clamping plate double
4	XSZB108	Bracket for M8 sensor
5	XS05B1PAL2	M8 inductive sensor-cable
6	XS508B1PAM8	M8 inductive sensor-M8
7	5570-DB4-IN	Sensor Bracket
8	XCMD2102L	Roll switch
9	5570-SD-ME	Switch bracket

# LT80 SERIES

Compact linear units with  
internal wheel- or rail guide

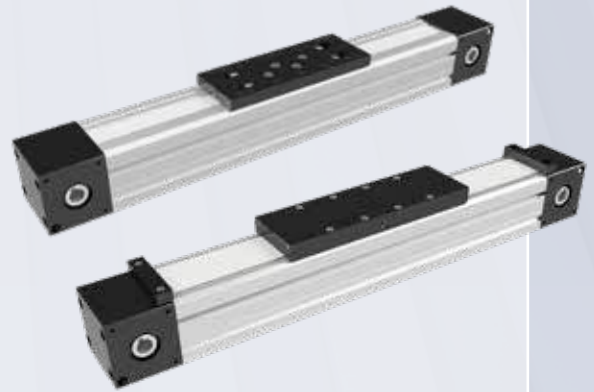

- Internal guide linear units, width of the profile 80 mm
- Optional metal protection band
- Internal recirculating ball rail guide size -20- for heavy loads
- Toothed belt type 32 AT10
- Advanced internal lubrication system

## TECHNICAL DATA\*

### LT80-TR-S20D

### LT80A-TR-S20D

Maximum stroke length	mm	5.750	5.750
Maximum speed	mm/s	3.000	3.000
Maximum acceleration	m/s <sup>2</sup>	30	30
No load torque	Nm	1,1	1,1
Max. driving torque	Nm	74	74
Repeatability	mm	± 0,1	± 0,1
Movement per revolution	mm	200	200

\*The values shown are theoretical maximum ratings. A suitable safety factor should always be applied based on application requirements.

# LT80 SERIES

## TECHNICAL DATA

### LOAD CAPACITY

		LT80-TR-S20D	LT80A-TR-S20D
Mx	Nm	86	86
My	Nm	126	126
Mz	Nm	50	50
Fx	N	4.400	4.400
Fy	N	1.400	1.400
Fz	N	1.400	1.400

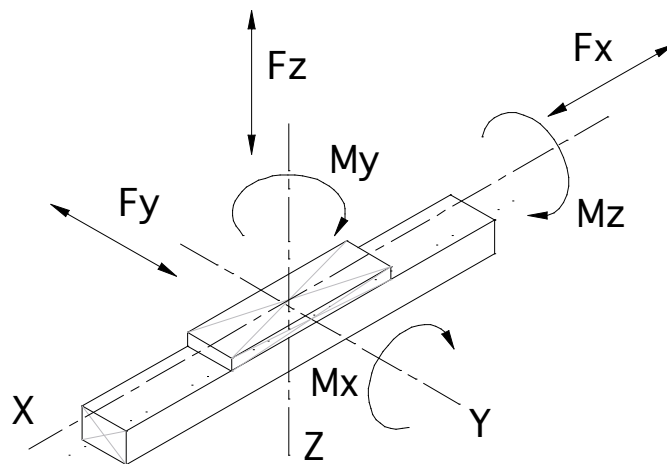

## MOMENT OF INERTIA (NMM<sup>2</sup>)

### LT60S-TR-S15D

Elx	5,009*10 <sup>10</sup>
Ely	7,415*10 <sup>10</sup>

## WEIGHTS (KG)

### LT60S-TR-S15D LT80A-TR-S20D

Unit weight 0 mm stroke	7,96	8,05
Weight per 100 mm stroke	0,72	0,80
Mass of carriage	2,25	2,40

# LT80 SERIES

## DIMENSIONS

### DIMENSIONS LT80-TR-S20D

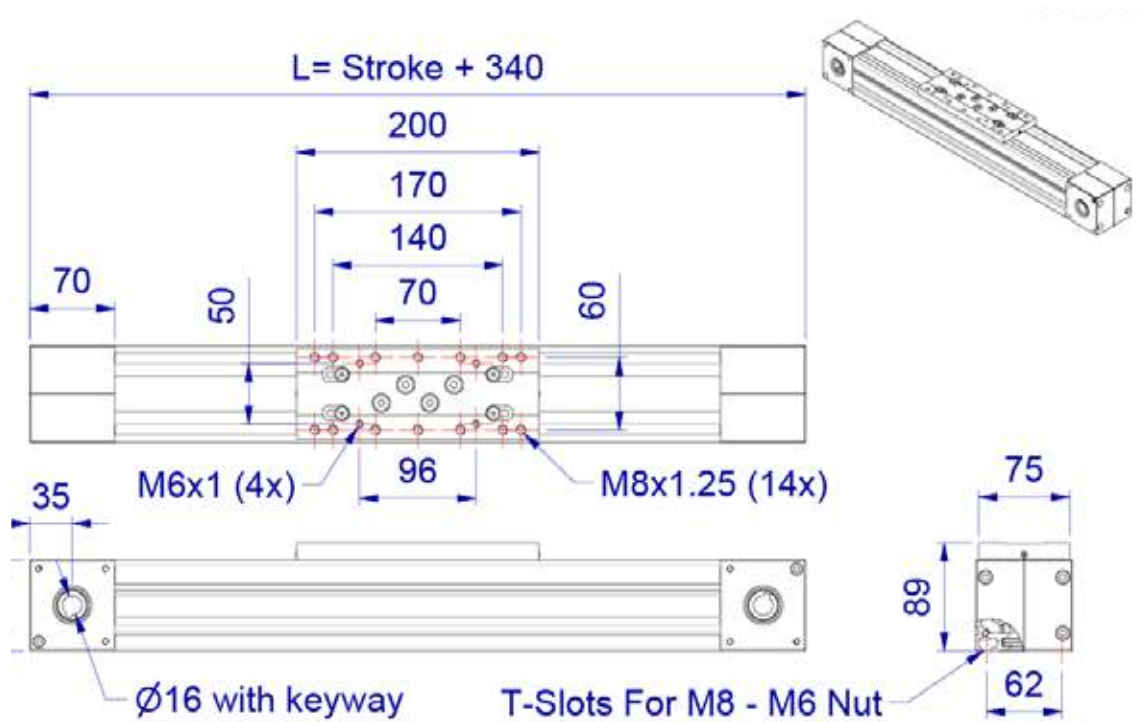

### DIMENSIONS LT80A-TR-S20D

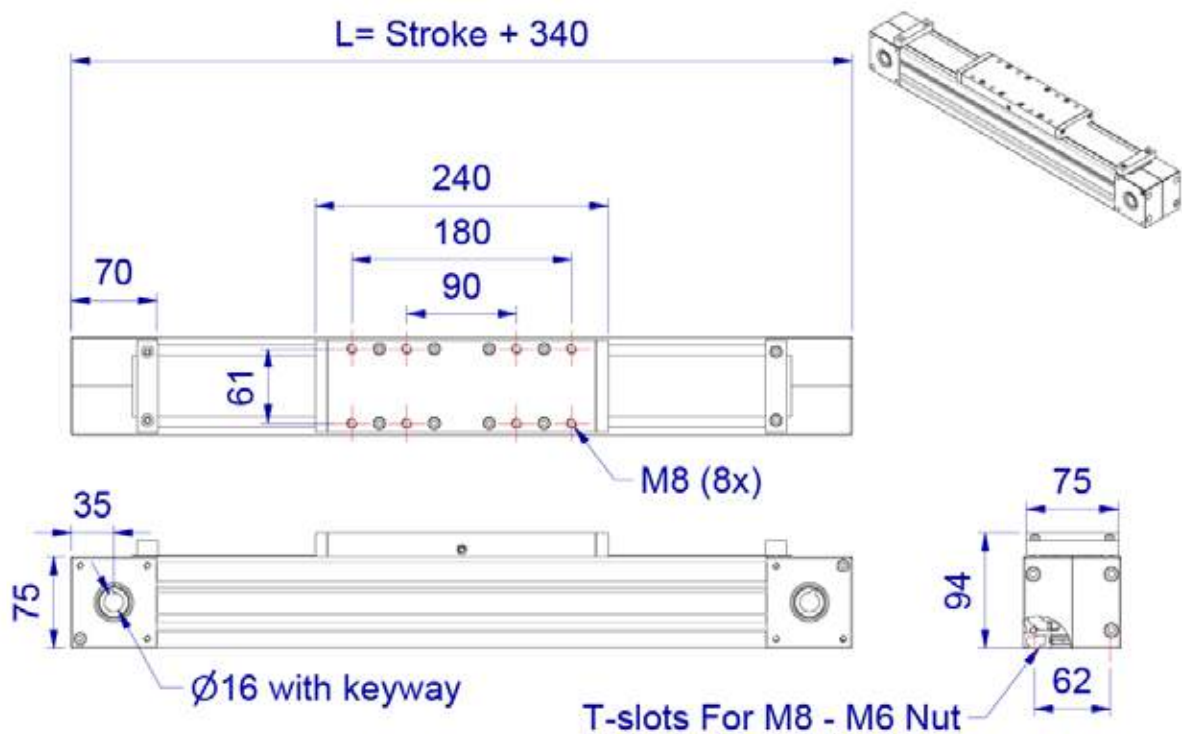

# LT80 SERIES

## DIMENSIONS

### DIMENSIONS FOR MOUNTING

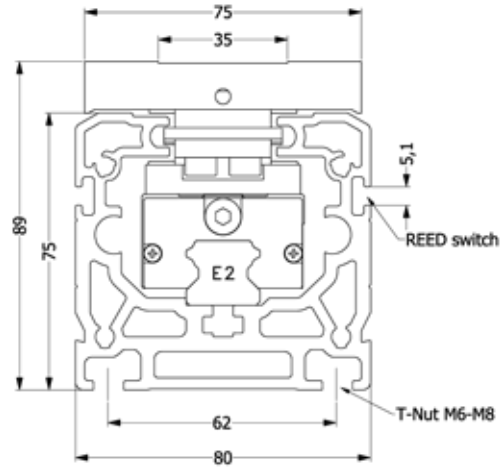

### CLAMPING DIMENSIONS

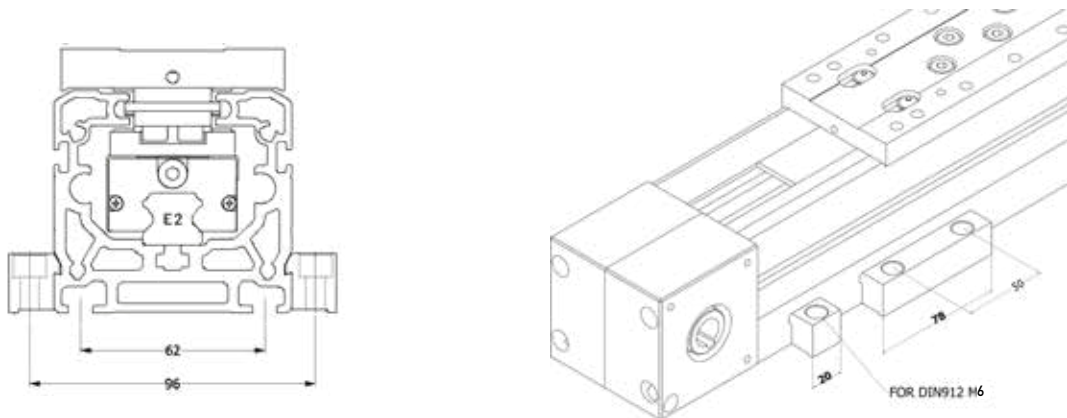

### DIMENSIONS FOR MOTOR ATTACHEMENT

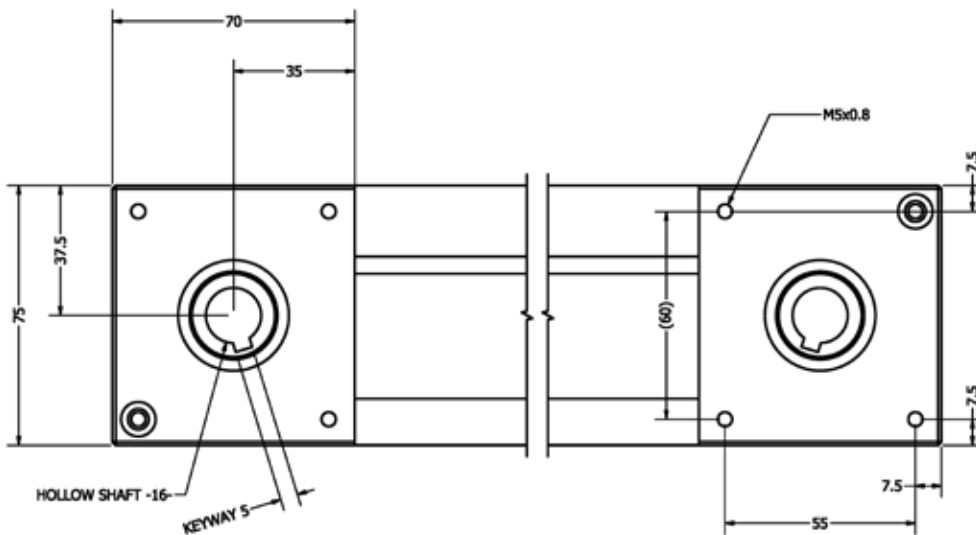

# LT80-TR-S20D

## MOTOR ACCESSORIES

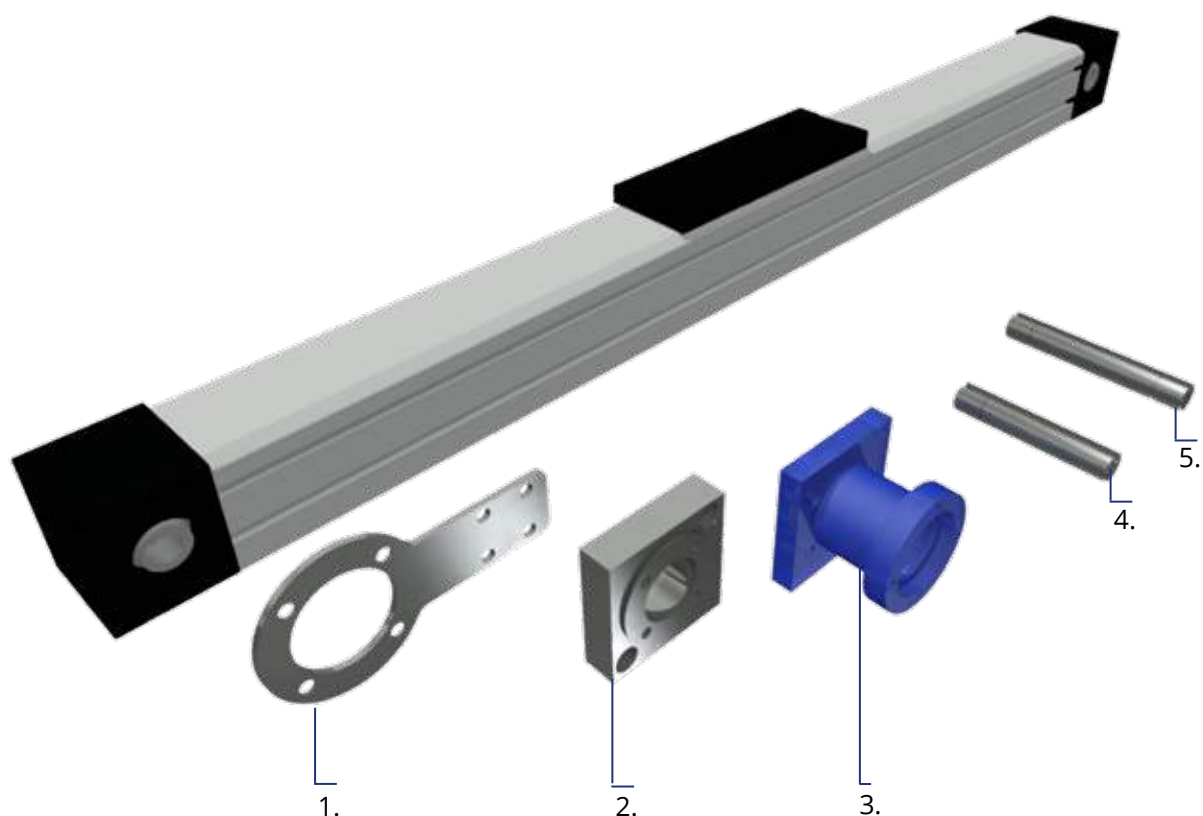

1	8070-RA-M-XXX	Motor adapter armtype
2	8070-F-XXX	Motor Flange
3	8070-FL-XXX	Motor adapter
4	8070-SS-16-GS19	Single shaft $\varnothing$ 16
5	8070-DS-16-GS19	Double shaft $\varnothing$ 16

# LT80-TR-S20D

## ACCESSORIES

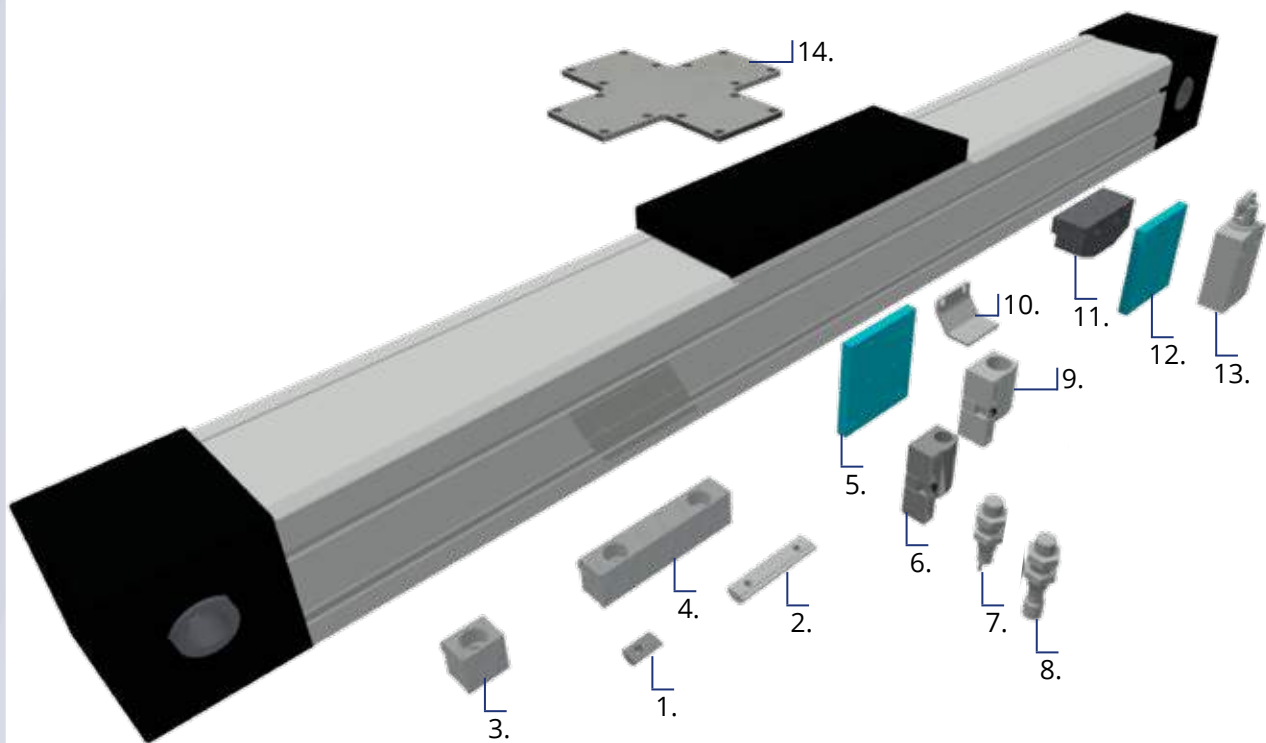

1	111-036	Single Nut M5
1	111-028	Single Nut M6
1	111-029	Single Nut M8
2	172-710	Double Nut M8 L=26
2	172-711	Double Nut M8 L=66
2	172-713	Double Nut M6 L=40
2	172-714	Double Nut M6 L=40
3	80121	Clamping plate single
4	80122	Clamping plate double
5	8070-SH-XS	Bracket for Telem. Bracket
6	XSZB108	Bracket for M8 sensor
7	XS05B1PAL2	M8 inductive sensor-cable
8	XS508B1PAM8	M8 inductive sensor-M8
9	XSZB112	Bracket for M12 sensor
10	8070-DB4-IN	Sensor bracket
11	8070-SD-ME	Switch bracket
12	8070-XCMD-B	Bracket for switch
13	XCMD2102L	Switch with roll
14	8070-XP-D	X-Cross-bracket

# LT80S SERIES

Compact linear units with  
internal wheel- or rail guide



- Internal guide units, width of the profile 80 mm
- Internal recirculating ball rail guide size -20- for heavy loads
- Carriage length 220 or 280 mm
- Toothed belt type 32 AT10
- Advanced internal lubrication system

## TECHNICAL DATA\*

## LT80S-TR-S20D

Maximum stroke length	mm	5.750
Maximum speed	mm/s	3.000
Maximum acceleration	m/s <sup>2</sup>	30
No load torque	Nm	0,8
Max. driving torque	Nm	74
Repeatability	mm	± 0,1
Movement per revolution	mm	200

\*The values shown are theoretical maximum ratings. A suitable safety factor should always be applied based on application requirements.

# LT80S SERIES

## TECHNICAL DATA

### LOAD CAPACITY

### LT80S-TR-S20D

Mx	Nm	720
My	Nm	960
Mz	Nm	220
Fx	N	4.400
Fy	N	7.400
Fz	N	7.400

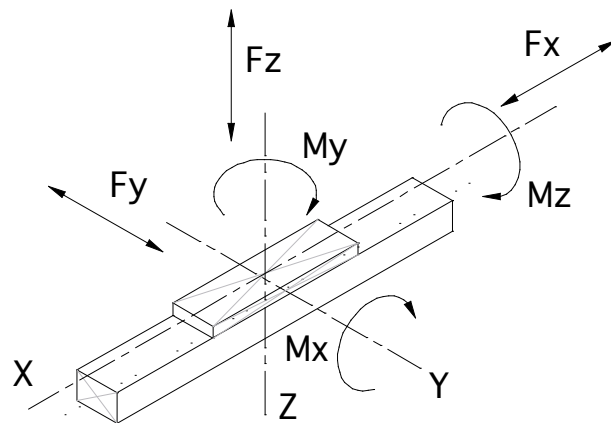

## MOMENT OF INERTIA (NMM<sup>2</sup>)

### LT80S-TR-S20D-(L)

Elx	5,009*10 <sup>10</sup>
Ely	1,034*10 <sup>11</sup>

## WEIGHTS (KG)

### LT80S-TR-S20D-(L)

Unit weight 0 mm stroke	6,85 (7,00)
Weight per 100 mm stroke	0,72
Mass of carriage	2,30 (2,45)

# LT80S SERIES

## DIMENSIONS

### DIMENSIONS LT80S-TR-S20D

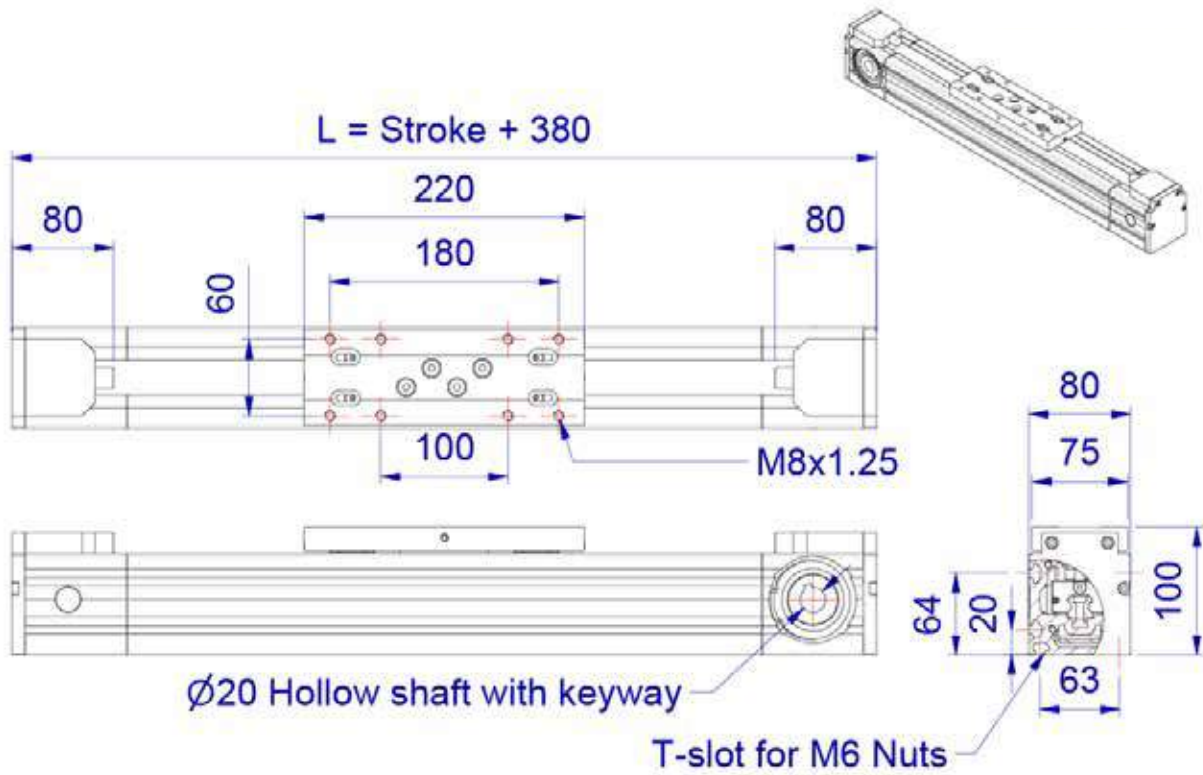

# LT80S SERIES

## DIMENSIONS

### DIMENSIONS FOR MOUNTING

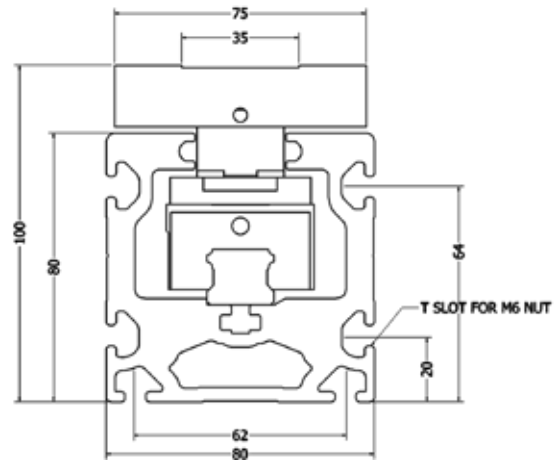

### CLAMPING DIMENSIONS

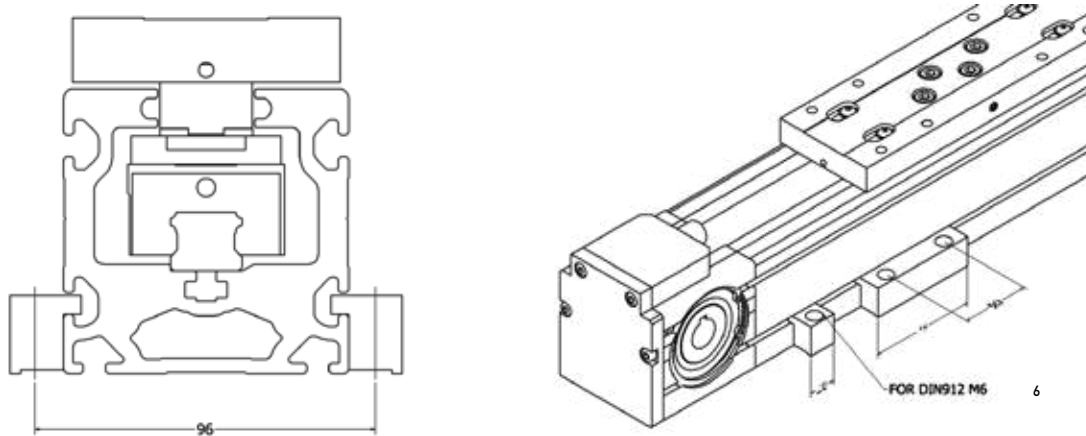

### DIMENSIONS FOR MOTOR ATTACHEMENT

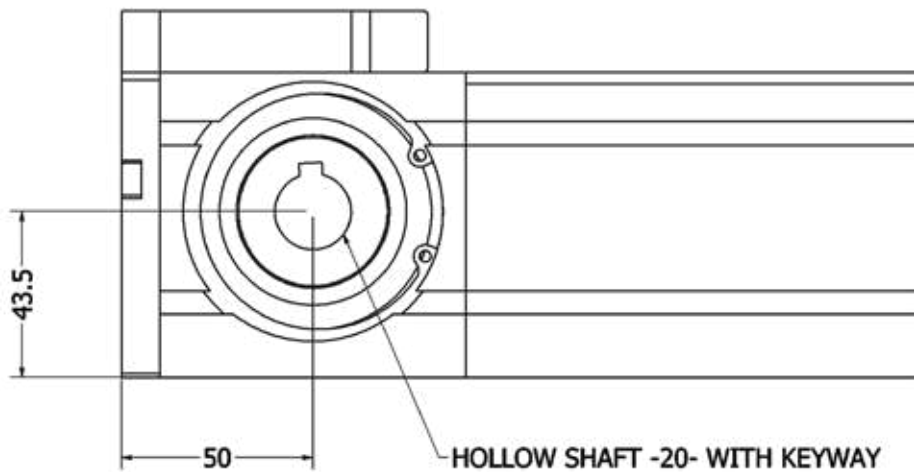

# LT80S-TR-S20D

## MOTOR ACCESSORIES

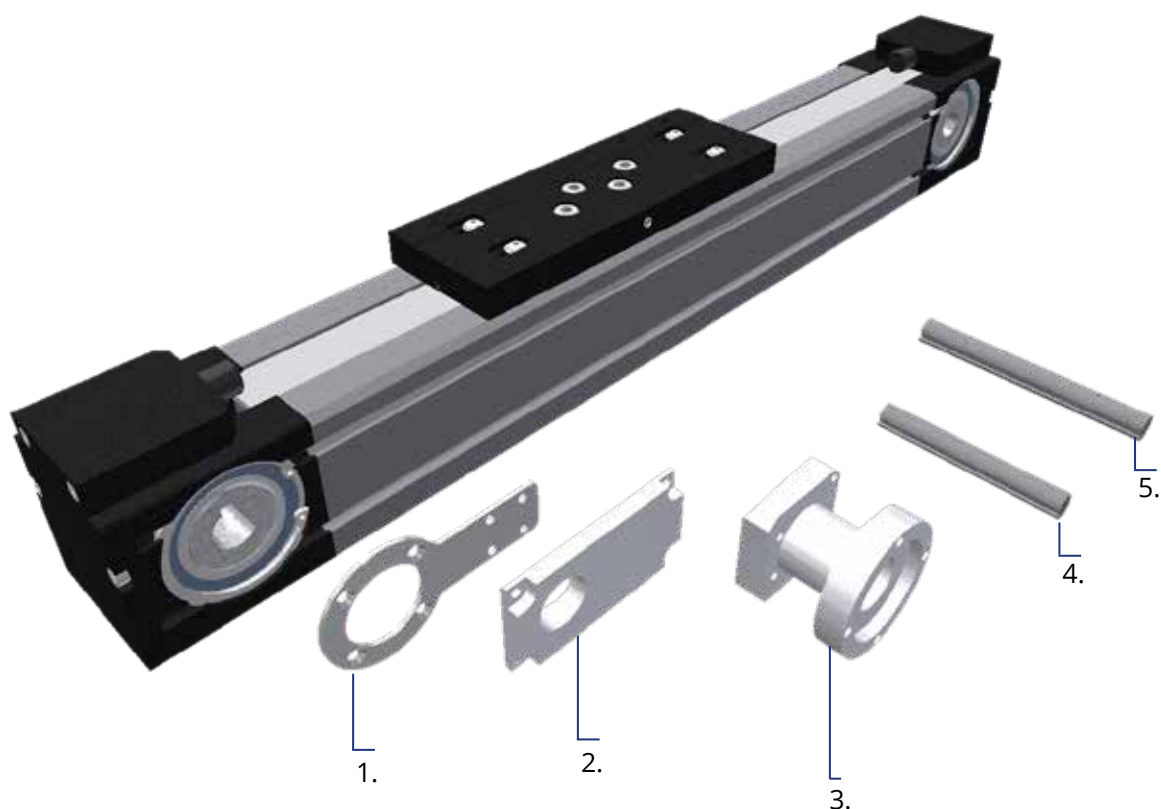

1	80S70-RA-M-XXX	Motor adapter armtype
2	80S70-F-XXX	Motor Flange
3	80S70-FL-XXX	Motor adapter
4	80S70-SS-20-GS19	Single shaft ø20
5	80S70-DS-20-GS19	Double shaft ø20

# LT80S-TR-S20D

## ACCESSORIES

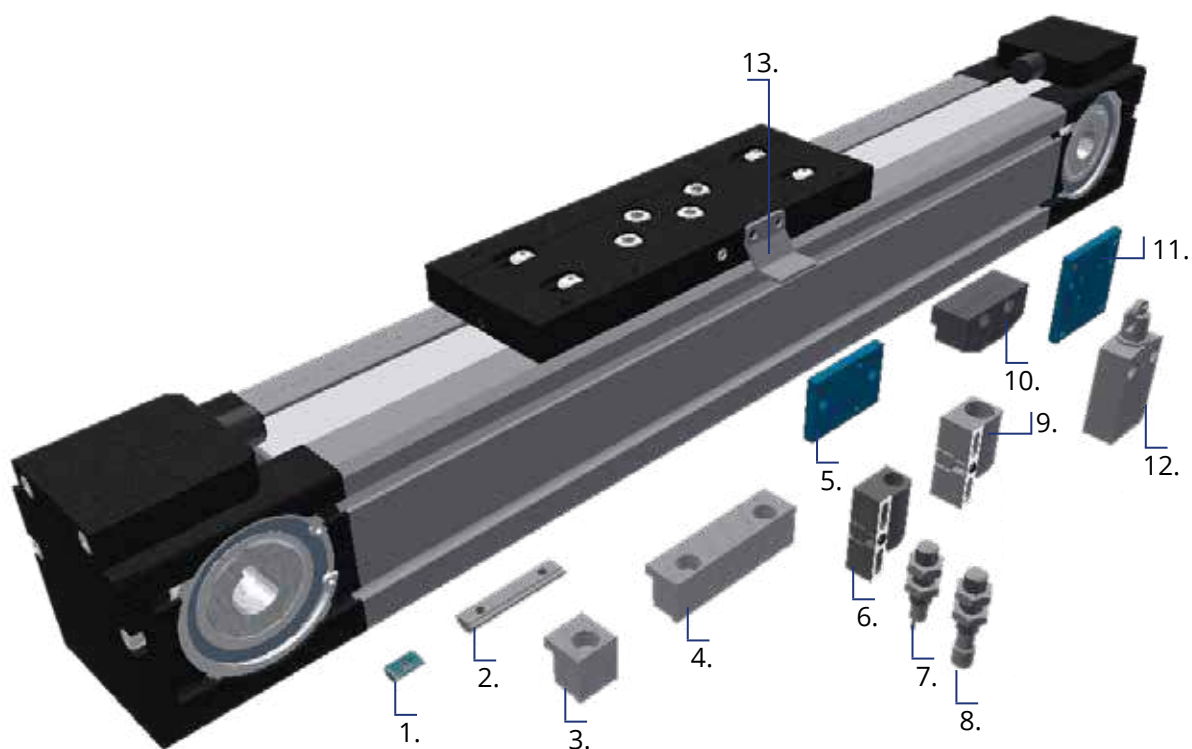

1	111-028-S	Single Nut M6 with spring
2	172-713S	Double Nut M6 L=40
3	80S121	Clamping plate single
4	80S122	Clamping plate double
5	8070-SH-XS-S	Bracket for Telem. Bracket
6	XSZB108	Bracket for M8 sensor
7	XS05B1PAL2	M8 inductive sensor-cable
8	XS508B1PAM8	M8 inductive sensor-M8
9	XSZB112	Bracket for M12 sensor
10	8070-DB4-IN	Sensor bracket
11	8070-SD-ME	Switch bracket
12	8070-XCMD-B	Bracket for switch
13	XCMD2102L	Switch with roll

# LTY200 SERIES

Linear units with toothed belt drive  
and double rail guide system

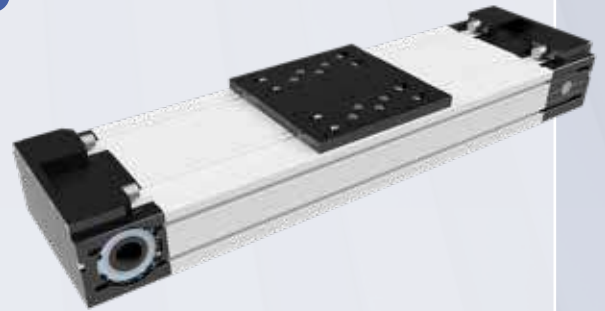

- Extrusion profile 80 x 200 mm
- Rail Guide system size -20- with 4 LM blocks
- Very heavy load capacity
- Double Toothed belt type AT10, 32mm wide

## TECHNICAL DATA\*

## LTY200

Maximum stroke length	mm	5.500
Maximum speed	mm/s	3.000
Maximum acceleration	m/s <sup>2</sup>	30
Max. driving torque	Nm	110
Repeatability	mm	± 0,1
Movement per revolution	mm	200

\*The values shown are theoretical maximum ratings. A suitable safety factor should always be applied based on application requirements.

# LTY200 SERIES

## TECHNICAL DATA\*

### LOAD CAPACITY LTY200

Mx	Nm	1.600
My	Nm	1.700
Mz	Nm	1.250
Fx	N	5.000
Fy	N	14.800
Fz	N	14.800

\*Please ask us for specific calculations of the guide system.

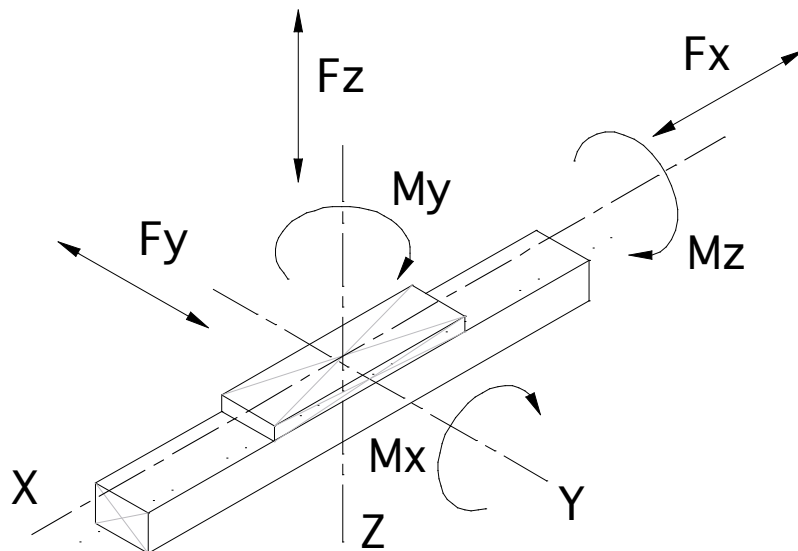

### WEIGHTS (KG)

#### LTY200

Unit weight 0 mm stroke	6,45
Weight per 100 mm stroke	1,05
Mass of carriage	0,90

# LTY SERIES

## DIMENSIONS

### DIMENSIONS LTY200

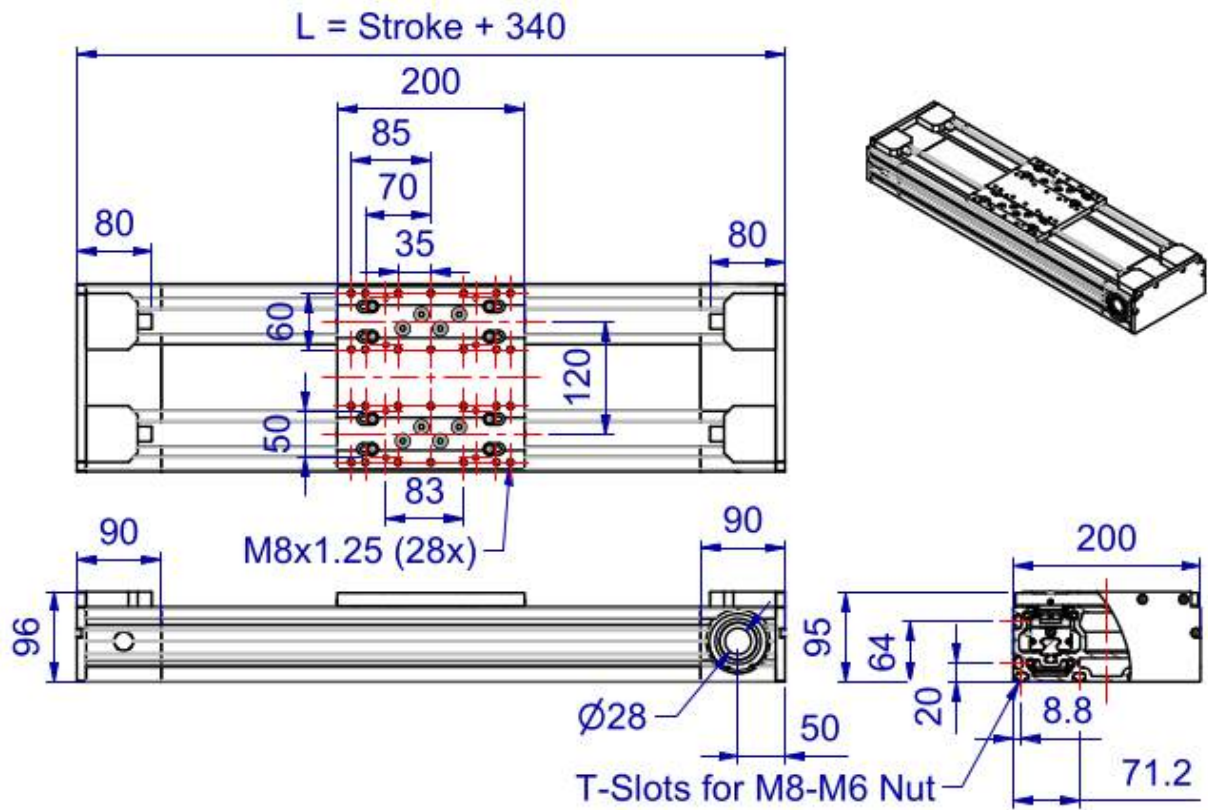

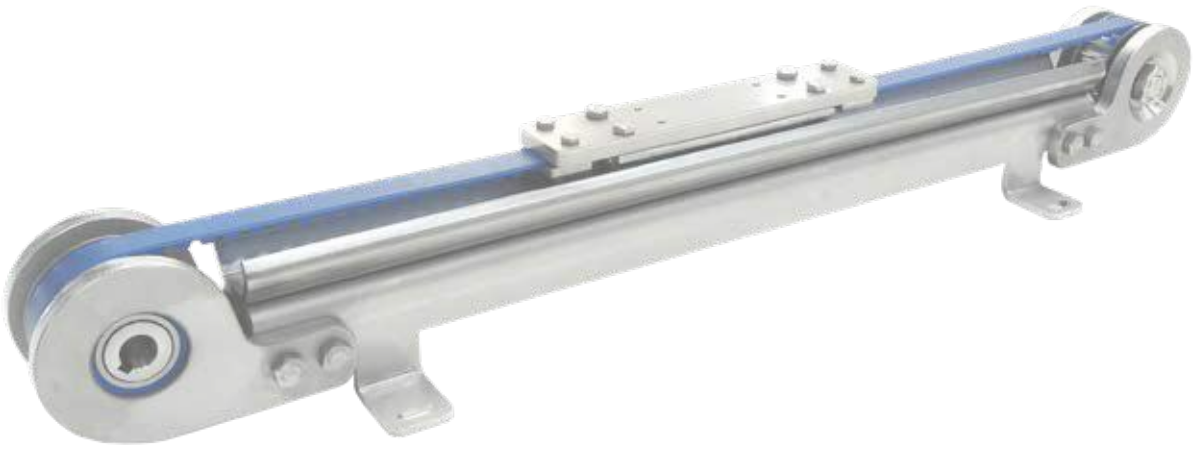

# LTi45 SERIES

Robust linear units with wheel- or rail guide in stainless steel

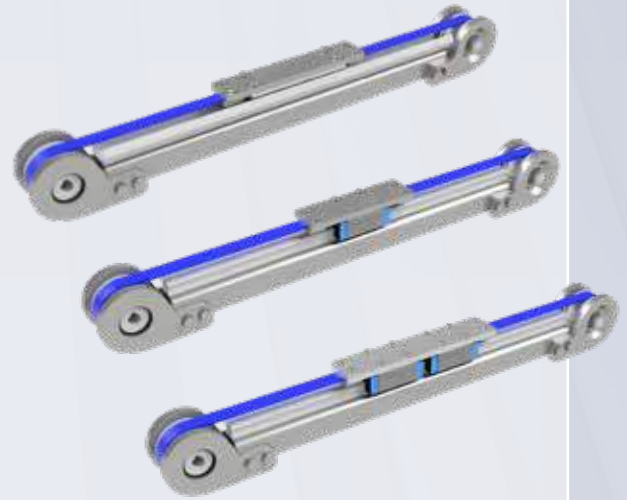

- Open design, the width of the profile is 45 mm
- Guide system of hardened wheels or recirculating rail guide, size -20-
- Toothed belt type AT10, 16 mm wide, in FDA blue version
- Double carriage design for high load
- C45 guide wheel system is very resistant to pollution
- Recirculating ball rail guide for heavy loads
- All components in inox mate

## TECHNICAL DATA\*\*

### LTI45-TRB-C45

### LTI45-TRB-S20I

Maximum stroke*	mm	5.500	3.000
Maximum speed	mm/s	1.500	1.500
Maximum acceleration	m/s <sup>2</sup>	30	30
No load torque	Nm	0,2	0,6
Repeatability	mm	± 0,1	± 0,1
Movement per revolution	mm	200	200

\* longer lengths on request

\*\*The values shown are theoretical maximum ratings. A suitable safety factor should always be applied based on application requirements.

# LTI45 SERIES

## TECHNICAL DATA

### LOAD CAPACITY

		LTI45-TRB-C45	LTI45-TRB-S20I	LTI45-TRB-S20ID
Mx	Nm	80	140	680
My	Nm	120	280	560
Mz	Nm	8	140	680
Fx	N	2.100	2.100	2.100
Fy	N	1.600	3.600	8.000
Fz	N	860	3.600	8.000

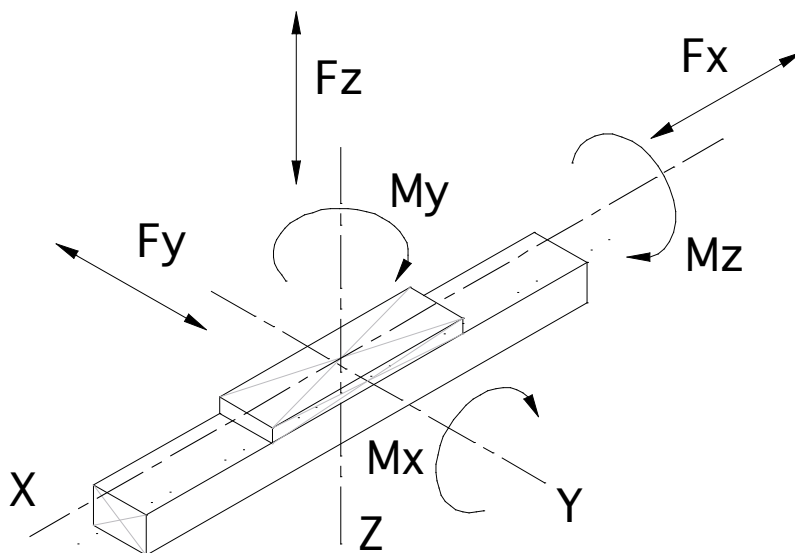

## WEIGHTS (KG)

### 

	LTI45-TRB-C45	LTI45-TRB-S20I	LTI45-TRB-S20ID
Unit weight 0 mm stroke	5,00	5,10	5,60
Weight per 100 mm stroke	0,40	0,45	0,45
Mass of carriage	0,70	0,90	1,10

# LTi45 SERIES

## DIMENSIONS

### DIMENSIONS LTI45-TRB-C45

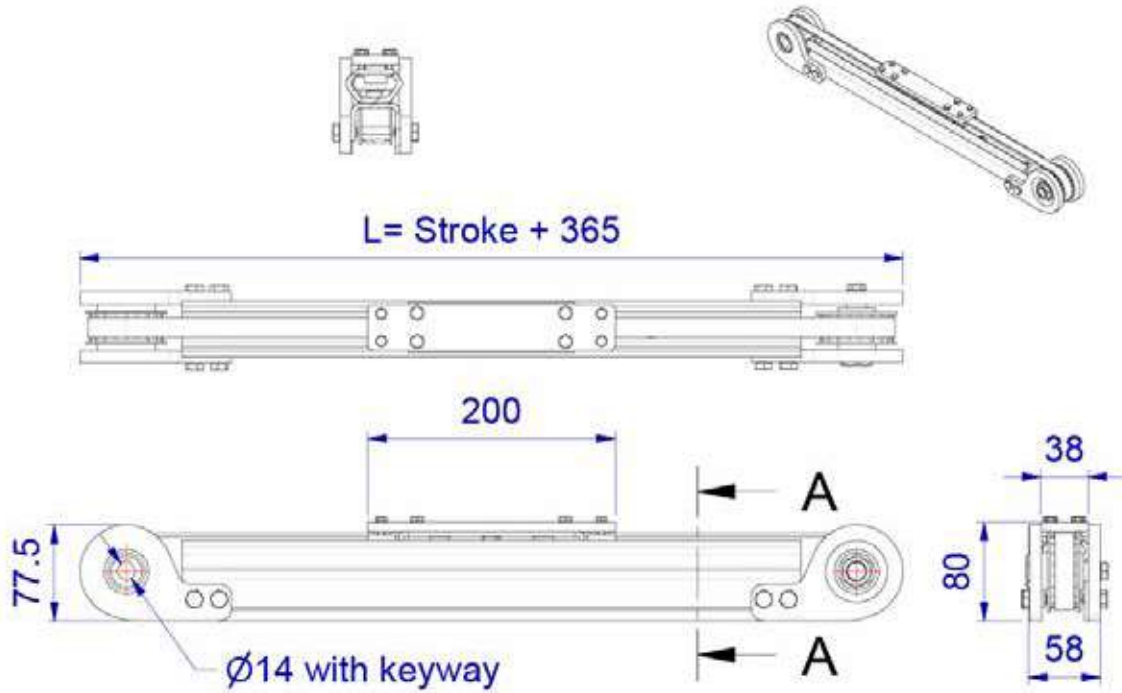

### DIMENSIONS LTI45-TRB-S20I / S20I-D

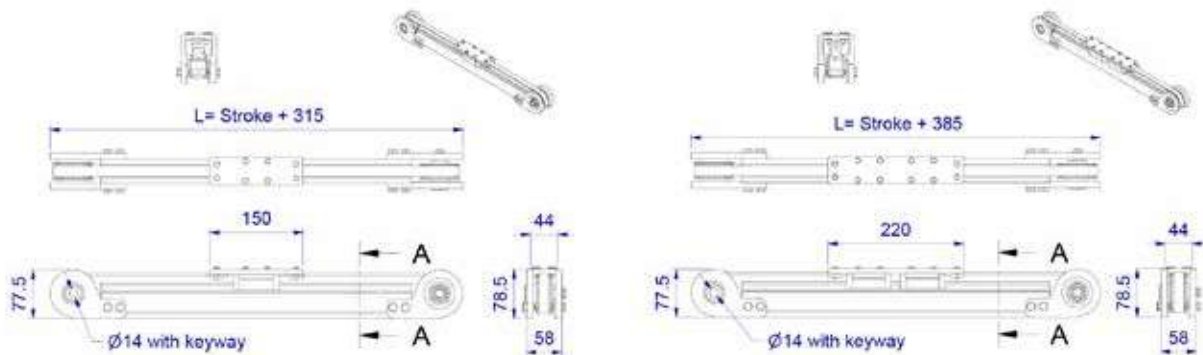

# LTi60 SERIES

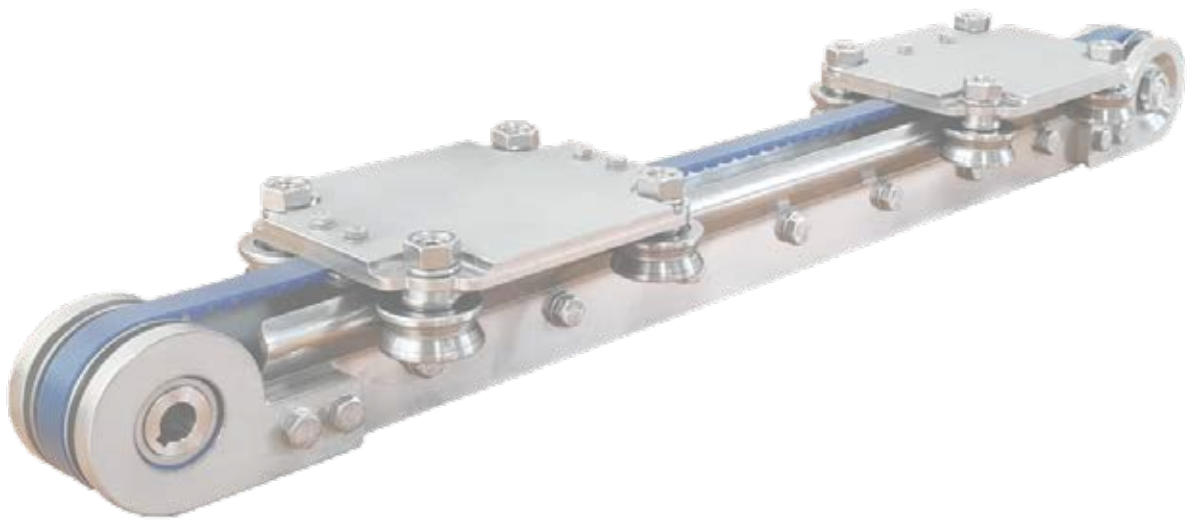

# LTi60 SERIES

Robust linear units with  
wheel guide in stainless steel  
Hygienic design

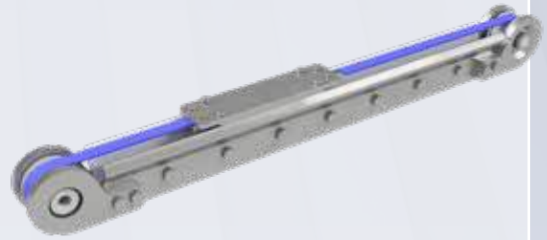

- Open design, the width of the profile is 55 mm
- Guide system of hardened wheels
- Toothed belt type AT10, in FDA blue version
- Easy to clean
- C45 guide wheel system is very resistant to pollution
- All components in inox mate

## TECHNICAL DATA\*\*

## LTI60-TRB-C45

Maximum stroke*	mm	2.300
Maximum speed	mm/s	1.500
Maximum acceleration	m/s <sup>2</sup>	30
No load torque	Nm	0,2
Repeatability	mm	± 0,1
Movement per revolution	mm	200

\* longer lengths on request

\*\* The values shown are theoretical maximum ratings. A suitable safety factor should always be applied based on application requirements.

# LTi60 SERIES

## TECHNICAL DATA

### LOAD CAPACITY

LTi60-TRB-C45

$M_x$	Nm	80
$M_y$	Nm	120
$M_z$	Nm	8
$F_x$	N	2.100
$F_y$	N	1.600
$F_z$	N	860

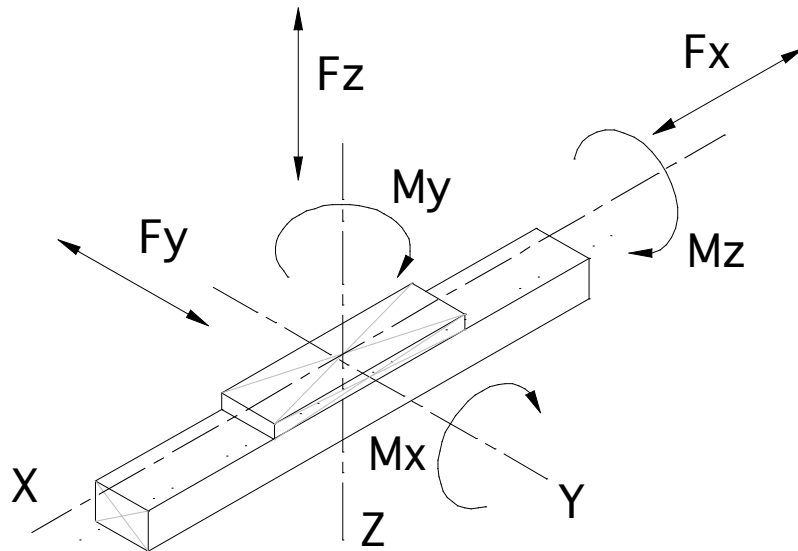

### WEIGHTS (KG)

LTi60-TRB-C45

Unit weight 0 mm stroke	5,00
Weight per 100 mm stroke	0,40
Mass of carriage	0,70

# LTi60 SERIES

## DIMENSIONS

### DIMENSIONS LTI60-TRB-C45

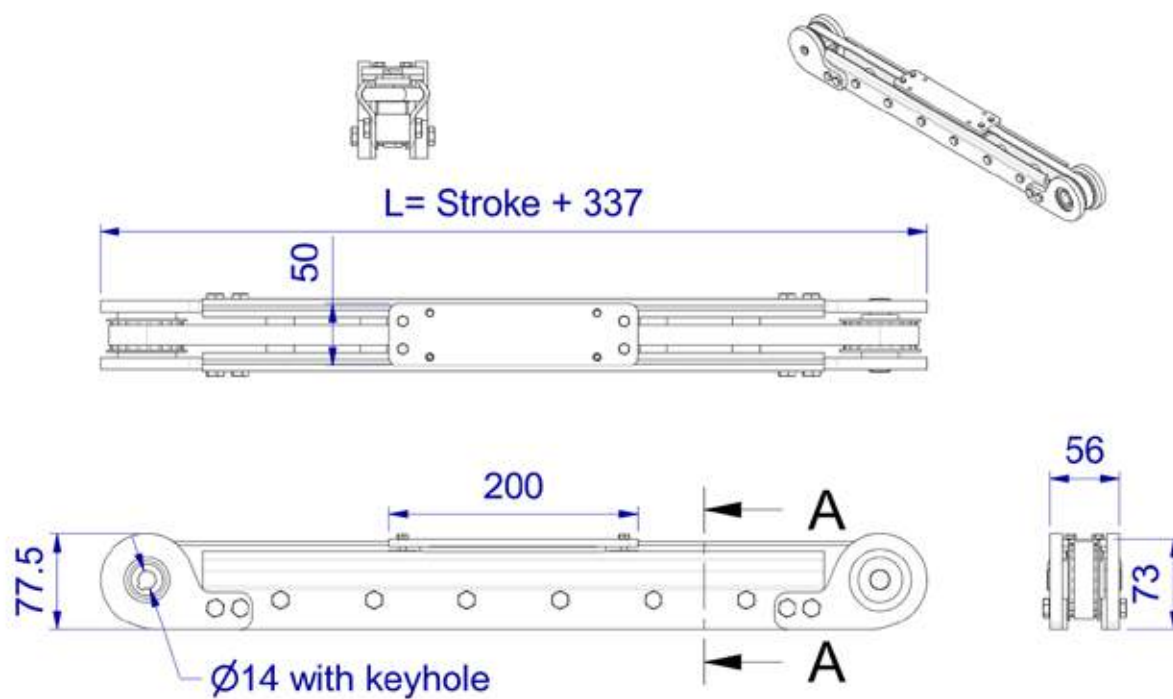

# STRUCTURAL DESIGN OMEGA LINEAR UNITS

LTZ50 LTZ55 LTZ80

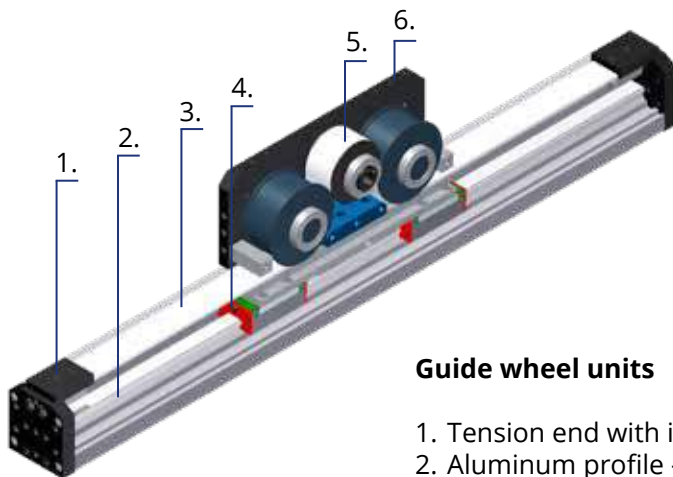

## Guide wheel units

1. Tension end with integrated belt tension system
2. Aluminum profile - hard anodized
3. AT polyurethane toothed belt with steel tension cords
4. Linear ball guide way
5. Drive block with pulley
6. Carriage plate



# CHARACTERISTICS OMEGA UNITS

The LTZ series contains Z-axis linear units, which are mostly used for vertical handling. These units contain a toothed belt drive, integrated ball rail system and compact dimensions. Our Omega units provide high performance features such as, high speed, good accuracy and repeatability. The linear units can also be combined with various multi-axis systems. All the linear units are designed and manufactured in The Netherlands, in consultation with the customer can Almotion offer the right and the best multi-axis application. Also, the linear units can be combined with other systems.

The compact, precision-extruded aluminum profile from 6063 with integrated ball rail guide system, allows high load capacities or larger masses at high speed are possible as well.

The linear units LTZ use a pre-tensioned, steel reinforced AT polyurethane timing toothed belt. Together with a zero-backlash drive pulley, high forces with alternating loads with good positioning accuracy, low wear and low noise can be realized. The polyurethane timing belt protects all the parts in the profile from dust and other contaminations.

The aluminum profile has T-slots for attaching sensors and switches. Also a magnetic reed switch can be used here. The end cap provides the possibility to attach a motor or gearbox housing and additional accessories on it.

**LTZ50**

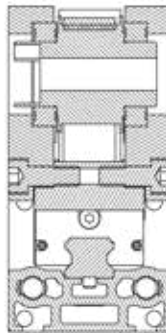

**LTZ55**

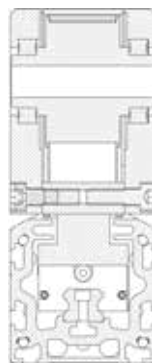

**LTZ80**





# LTZ50 SERIES

Robust linear units with guide

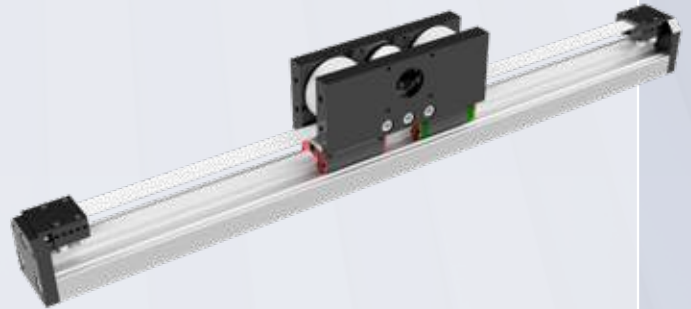

- Compact design, the width of the profile 50 mm
- Rail guide system, size -15-
- Double carriage design for high load
- Omega type belt for vertical applications
- Recirculating ball rail guide for heavy loads

## TECHNICAL DATA\*

## LTZ50-TR-S15D

Maximum stroke	mm	5.730
Maximum speed	mm/s	3.000
Maximum acceleration	m/s <sup>2</sup>	30
No load torque	Nm	1,1
Max. driving torque	Nm	8
Repeatability	mm	± 0,1
Movement per revolution	mm	100

\*The values shown are theoretical maximum ratings. A suitable safety factor should always be applied based on application requirements.

# LTZ50 SERIES

## TECHNICAL DATA

### LOAD CAPACITY

LTZ50-TR-S15D

$M_x$	Nm	106
$M_y$	Nm	106
$M_z$	Nm	40
$F_x$	N	1.000
$F_y$	N	3.400
$F_z$	N	3.600

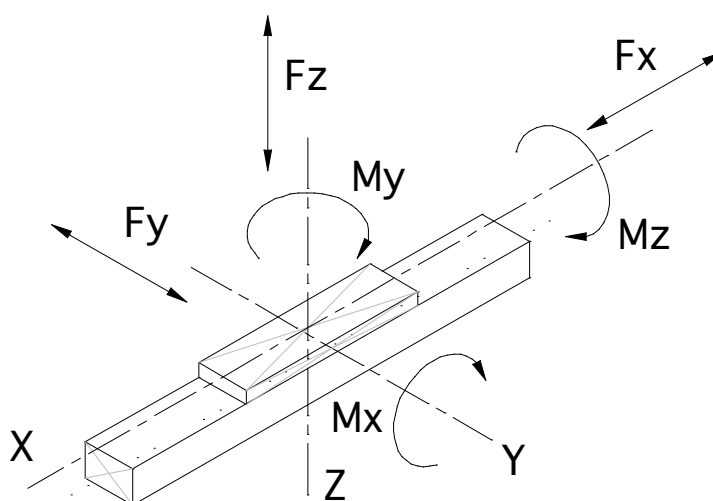

## WEIGHTS (KG)

LTZ50-TR-S15D

Unit weight 0 mm stroke	2,53
Weight per 100 mm stroke	0,28

# LTZ50 SERIES

## DIMENSIONS

### DIMENSIONS LTZ50-S15D

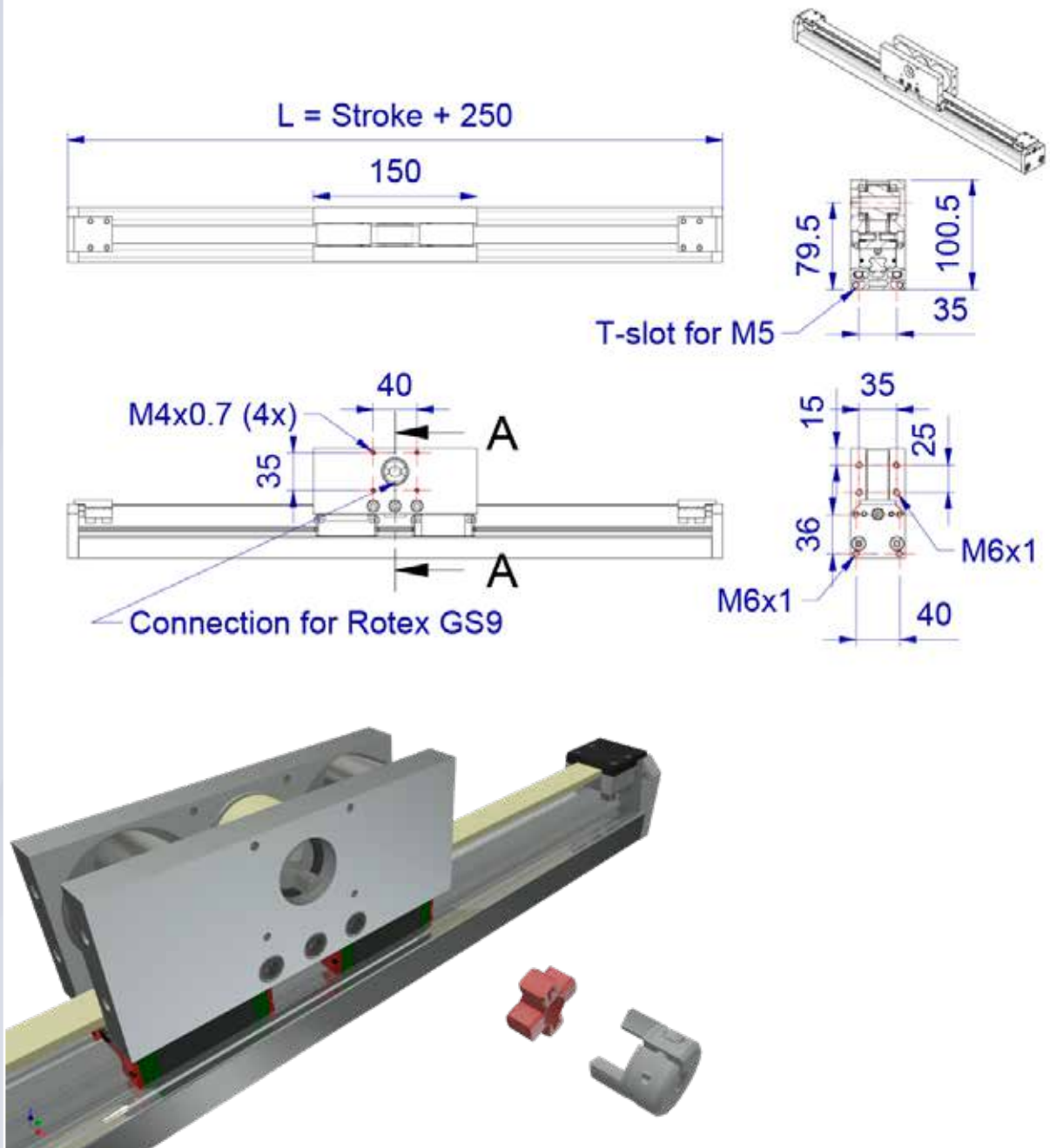

The LTZ50 Series is equipped with a pulley that has a connection for the Rotex GS9 flexible shaft coupling. This allows compact mounting of the gearbox / motor.

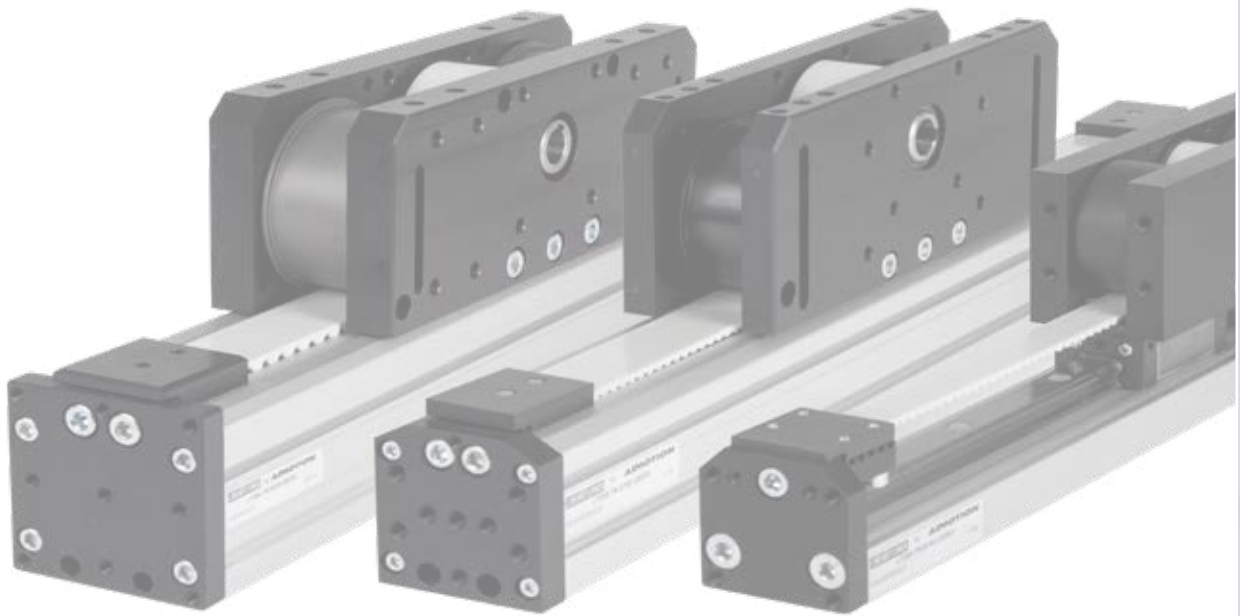

# LTZ55 SERIES

Compact linear units with  
internal rail guide

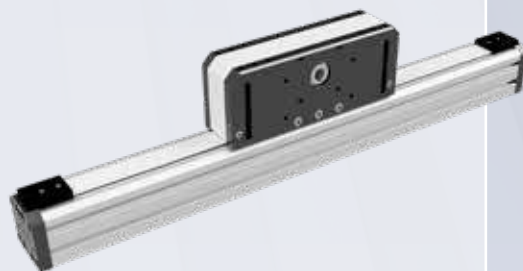

- Compact design, the width of the profile 55 mm
- Internal recirculating ball rail guide size -15 -
- Double carriage design for heavier loads
- Toothed belt type 25 AT5

## TECHNICAL DATA\*

## LTZ55-TR-S15D

Maximum stroke length	mm	3.000
Maximum speed	mm/s	3.000
Maximum acceleration	m/s <sup>2</sup>	30
No load torque	Nm	1,2
Max. driving torque	mm	14
Repeatability	mm	± 0,1
Movement per revolution		150

\* The values shown are theoretical maximum ratings. A suitable safety factor should always be applied based on application requirements.

# LTZ55 SERIES

## TECHNICAL DATA

### LOAD CAPACITY

### LTZ55-TR-S15D

$M_x$	Nm	120
$M_y$	Nm	120
$M_z$	Nm	40
$F_x$	N	1.200
$F_y$	N	3.400
$F_z$	N	3.600

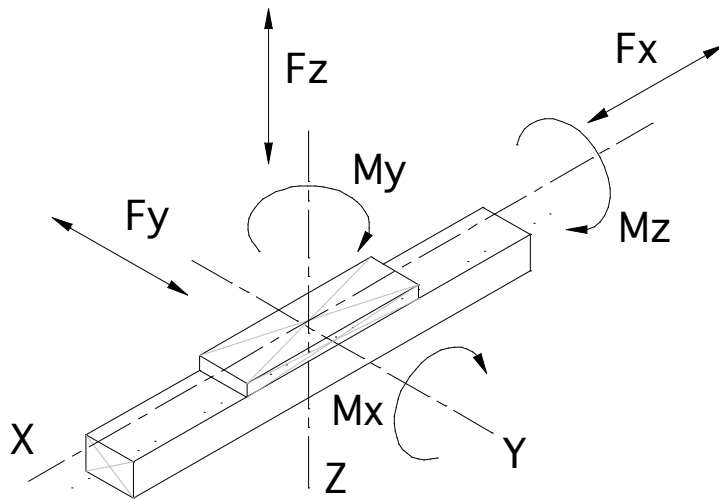

## WEIGHTS (KG)

### LTZ55-TR-S15D

Unit weight 0 mm stroke	4,90
Weight per 100 mm stroke	0,40

# LTZ55 SERIES

## DIMENSIONS LTZ55-TR-S15D

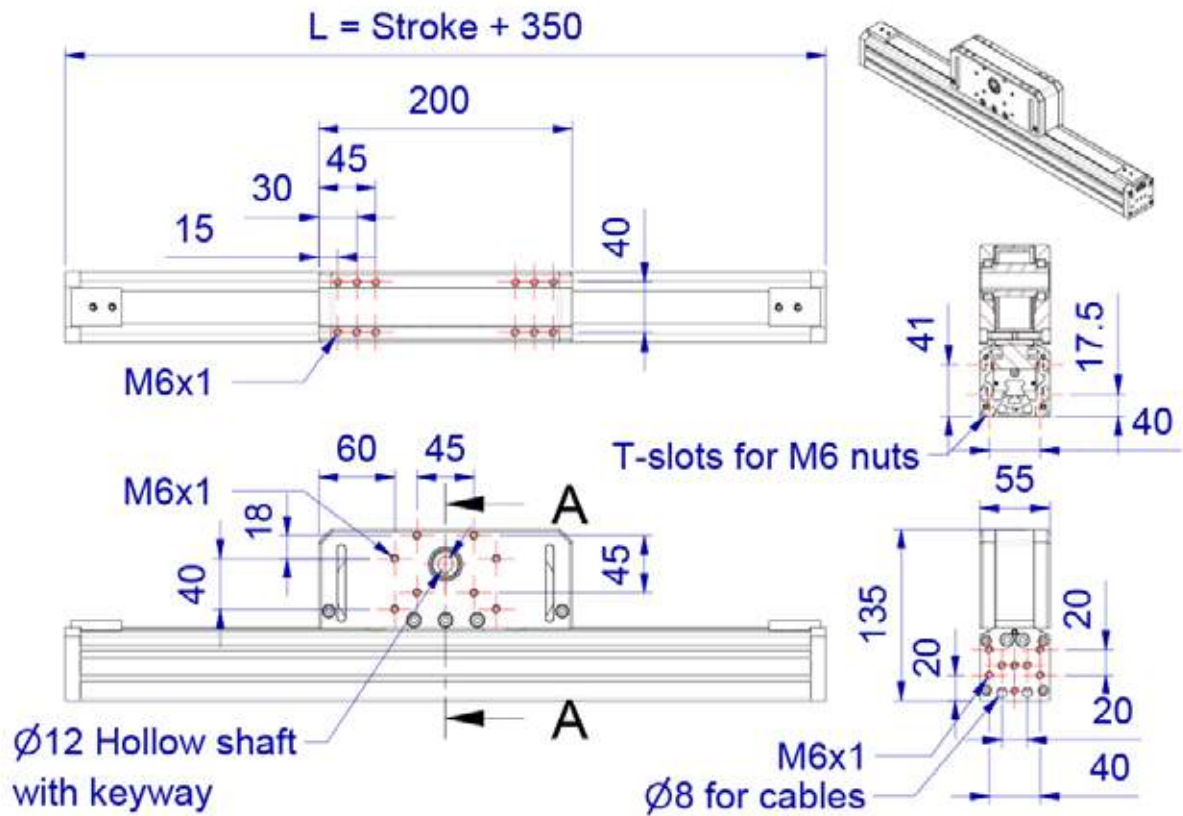

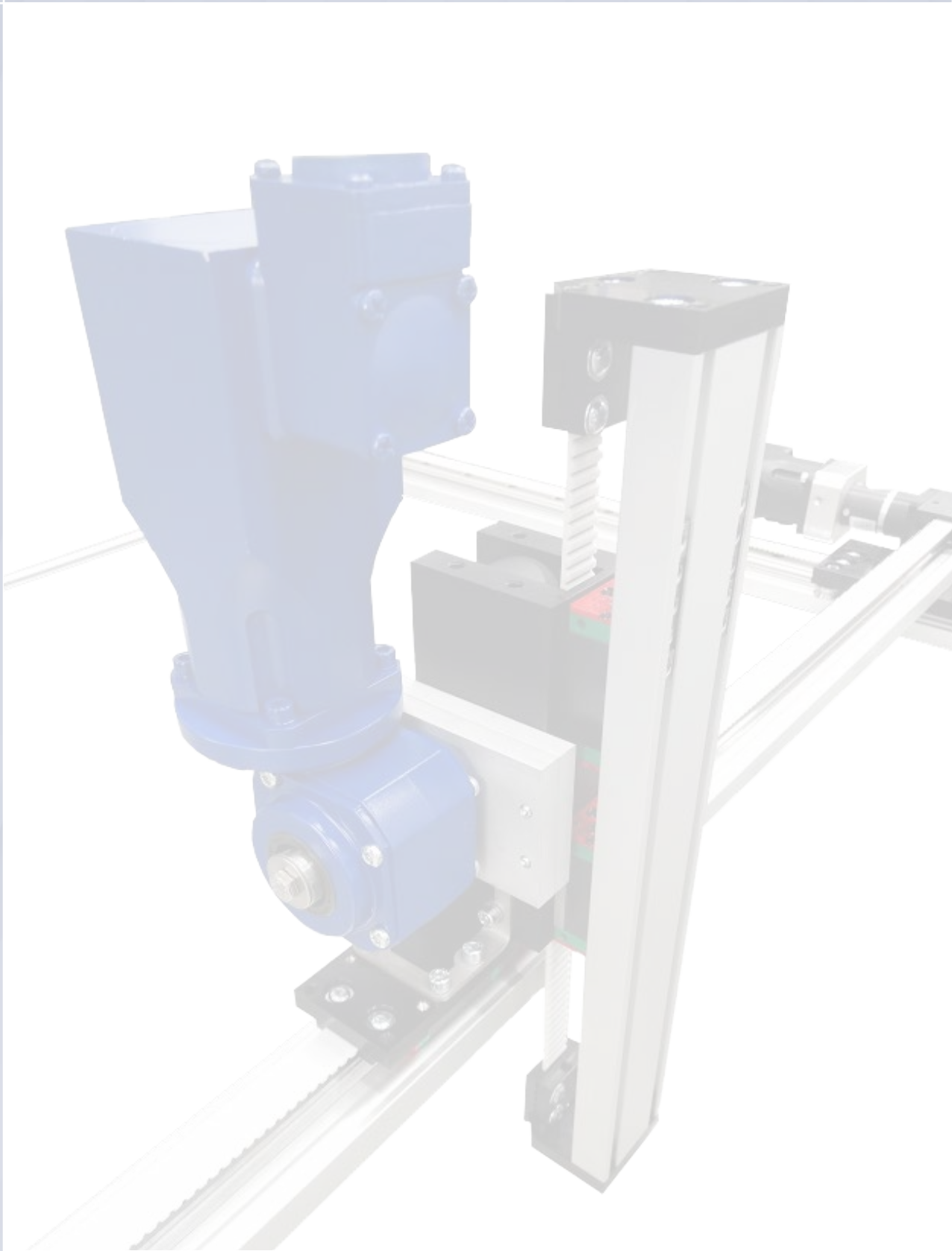

# LTZ80 SERIES

Compact linear units with  
internal rail guide



- Internal guide linear units, width of the profile 80 mm
- Internal recirculating ball rail guide size - 20 - for heavy loads
- Toothed belt type 32 AT10
- Omega belt construction

## TECHNICAL DATA\*

## LTZ80-TR-S20D

Maximum stroke length	mm	5.700
Maximum speed	mm/s	3.000
Maximum acceleration	m/s <sup>2</sup>	30
No load torque	Nm	0,9
Max. driving torque	Nm	74
Repeatability	mm	± 0,1
Movement per revolution	mm	200

\*The values shown are theoretical maximum ratings. A suitable safety factor should always be applied based on application requirements.

# LTZ80 SERIES

## TECHNICAL DATA

### LOAD CAPACITY

### LTZ80-TR-S20D

Mx	Nm	810
My	Nm	1.040
Mz	Nm	220
Fx	N	4.400
Fy	N	7.400
Fz	N	7.400

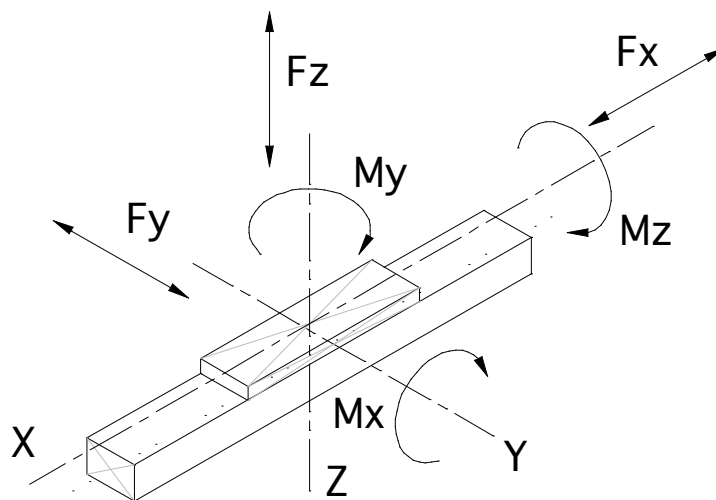

## WEIGHTS (KG)

### LTZ80-TR-S20D

Unit weight 0 mm stroke	9,41
Weight per 100 mm stroke	0,72

# LTZ80 SERIES

## DIMENSIONS LTZ80-TR-S20D

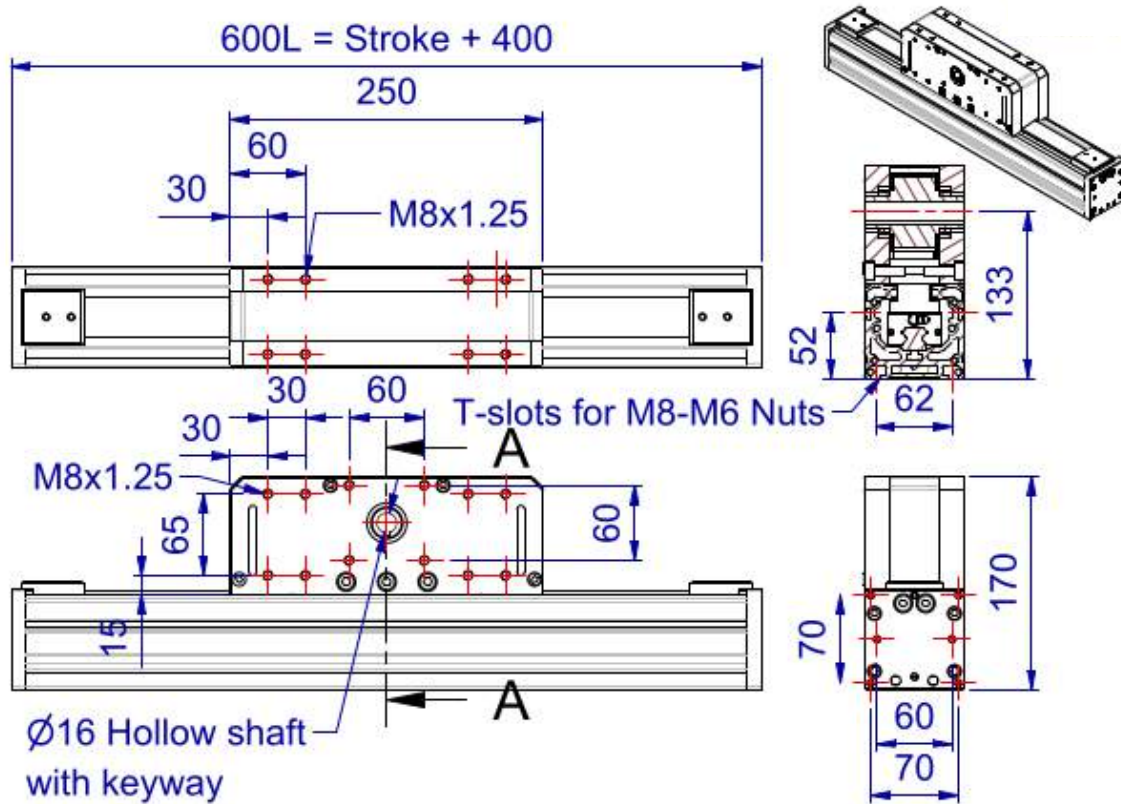

# ACCESSORIES OMEGA UNITS

## MOUNTING NUTS

T-slot nuts are available in the size for mounting the unit and accessories.

### L TZ55

**Article number:**  
111-012

**Description:**  
Square nut M5



### L TZ80

**Article number:**  
111-036  
111-028  
111-029  
172-710  
172-711  
172-713  
172-714

**Description:**  
M5 nut with fixing ball  
M6 nut with fixing ball  
M8 nut with fixing ball  
2x M8 plate L=26  
2x M8 plate L=66  
2x M6 plate L=40  
2x M8 plate L=40

## ELECTRONIC SWITCHES

Electronic and / or mechanical switches can be mounted to the carriage plate of the unit. The switches can detect on a steel block (inductive) or on a V-shaped plate. We can advise with the application of various brands of switches. Standard plates are available.

### L TZ55

**Article number :**  
5540-DB4-IN  
5540-SD-ME

**Description:**  
Sensor block for inductive sensor  
Sensor block for mechanical roll switch

### L TZ80

**Article number :**  
8040-DB4-IN  
8040-SD-ME

**Description:**  
Sensor block for inductive sensor  
Sensor block for mechanical roll switch



# ACCESSORIES OMEGA UNITS

## MOUNTING WITH CLAMPING BLOCKS

For rigid mounting of the LTZ Omega units clamping blocks can be used. Clamping blocks are designed so that the LTZ Omega units can be mounted directly to the standard LT 55 / 80 units.

**Article number:**

55Z55-122

55Z80-122

80Z80-122

**Description:**

Double bore clamping block for mounting LTZ55 to LT55

Double bore clamping block for mounting LTZ55 to LT80

Double bore clamping block for mounting LTZ80 to LT80

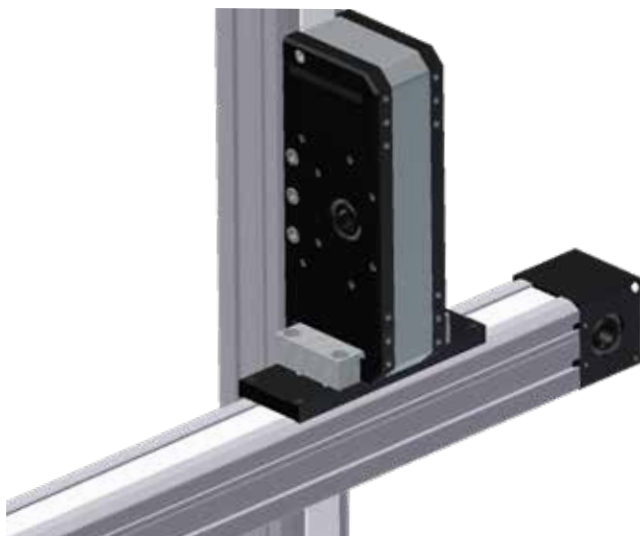

## SHOCK ABSORBERS "IN CASE OF EMERGENCY"

Safety end stops can be mounted on the LTZ linear units so the energy is absorbed in case of a crash.

**Article number:**

SC300-5-TAM3-18

SC64-5

TC64-62-S

55Z-SC300-MB

80Z-SC64-MB

55Z-TC64-MB

80Z-TC64-MB

**Description:**

ACE Hydraulic Shock absorber

ACE Hydraulic Shock absorber

ACE Rubber Shock absorber

Mounting Bracket for Hydraulic Shock absorber to LTZ55

Mounting Bracket for Hydraulic Shock absorber to LTZ80

Mounting Bracket for Rubber Shock absorber to LTZ55

Mounting Bracket for Rubber Shock absorber to LTZ80



# MODULAR GUIDE UNITS, STRUCTURAL DESIGN

## COMBINATIONS

### LTC SERIES

The LTC series are modular build, there are many possible combinations. The base is formed by an aluminum profile with a guide rail mounted.

### STANDARD COMBINATIONS

C10-D1

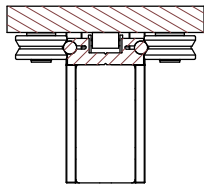

C10-S2

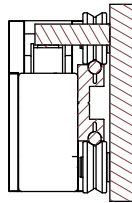

C10-S1

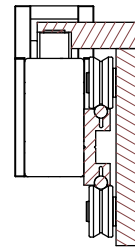

C12-D1

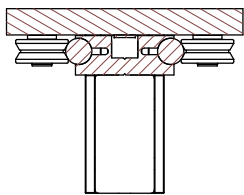

C12-S2

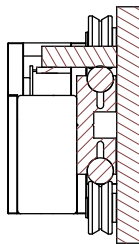

C12-S1

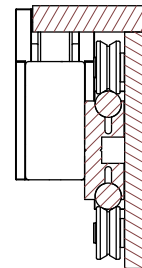

C16-D1

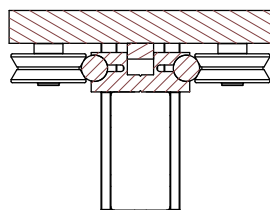

C16-S2

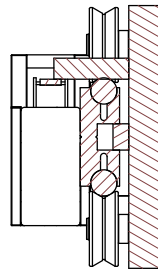

C16-S1

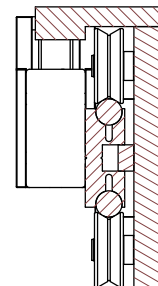

G20

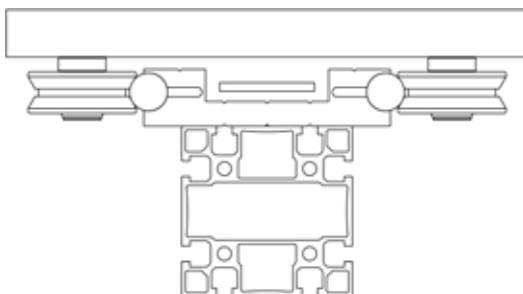

## CHARACTERISTICS

The LTC modular Series contains linear units which are built from most standard components, such as aluminium profiles and linear guides into a linear unit that best fits the application. As base several sizes of 'catalogue' aluminium profiles can be used from 40x80 to 90x90 size. These units contain a toothed belt drive, integrated ball rail system and compact dimensions.

They provide high performance features such as, high speed, good accuracy and repeatability. The LTC series units can also be combined with various multi-axis systems. All the linear units are designed and manufactured in The Netherlands, in consultation with the customer Almotion can offer the right and the best multi-axis application. Also, the linear units can be combined with other systems. The compact, precision-extruded aluminium profile from 6063 alloy with various guide system, allowing high load capacities or larger masses at high speed are possible as well.

The linear units use a pre-tensioned, steel reinforced AT polyurethane timing toothed belt. Together with a zero-backlash drive pulley, high forces with alternating loads with good positioning accuracy, low wear and low noise can be realized. The aluminium profile has T-slots for attaching sensors and switches. The endcaps are easy to attach a motor or gearbox housing and additional accessories on it. There are 2 possibilities in the position of the endcaps so that long strokes can be reached with the correct belt position.



# MODULAR GUIDE UNITS

## LTC SERIES

Linear units with toothed belt drive and guide wheel system

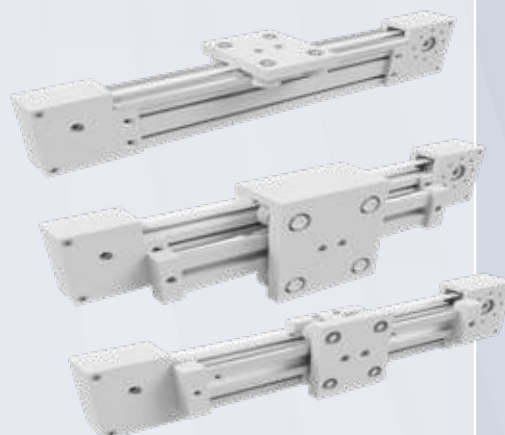

- Basic extrusion profile 45 x 90, 45 x 135 or 90 x 90 mm
- Guide system of hardened wheels on hardened shafts
- Toothed belt type AT10, 16, 25 or 50 mm wide
- Hardened and grinded V-shaped wheels
- Very resistant to pollution

### Technical data\*

### LTC series

Maximum stroke length	mm	42.000
Maximum speed	mm/s	5.000
Maximum acceleration	m/s <sup>2</sup>	50
Max. driving torque	Nm	37
Repeatability	mm	± 0,1
Movement per revolution	mm	200

\*The values shown are theoretical maximum ratings. A suitable safety factor should always be applied based on application requirements.

# LTC SERIES

## TECHNICAL DATA

LOAD CAPACITY		LTC-TR-C10	LTC-TR-C12	LTC-TR-C16	LTC-TR-G20
Mx	Nm	84	144	320	608
My	Nm	127	200	490	650
Mz	Nm	42	72	160	410
Fx	N	2.100	2.100	2.100	6.500
Fy	N	2.400	3.200	6.400	6.400
Fz	N	2.600	3.200	7.000	7.000

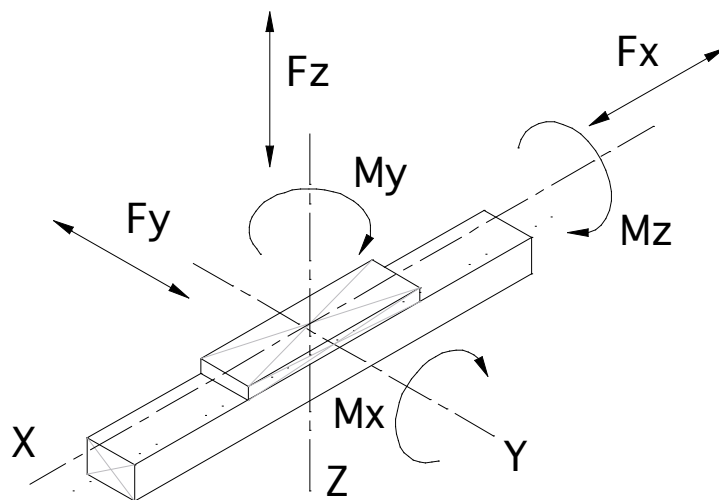

# LTC SERIES

## DIMENSIONS

### DIMENSIONS LTC-TR-C10-D1

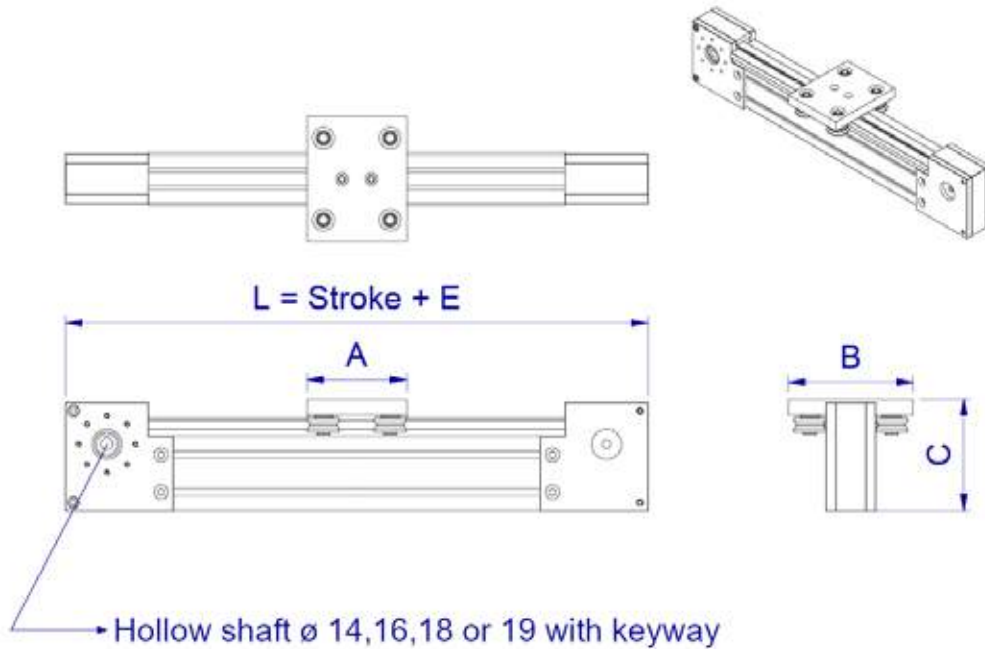

Type	A	B	C	D	E
C 10-D1	120	150	134,5	-	320
C 12-D1	150	180	140,5	-	350
C 16-D1	180	200	152,0	-	380

### DIMENSIONS LTC-TR-C10-S1

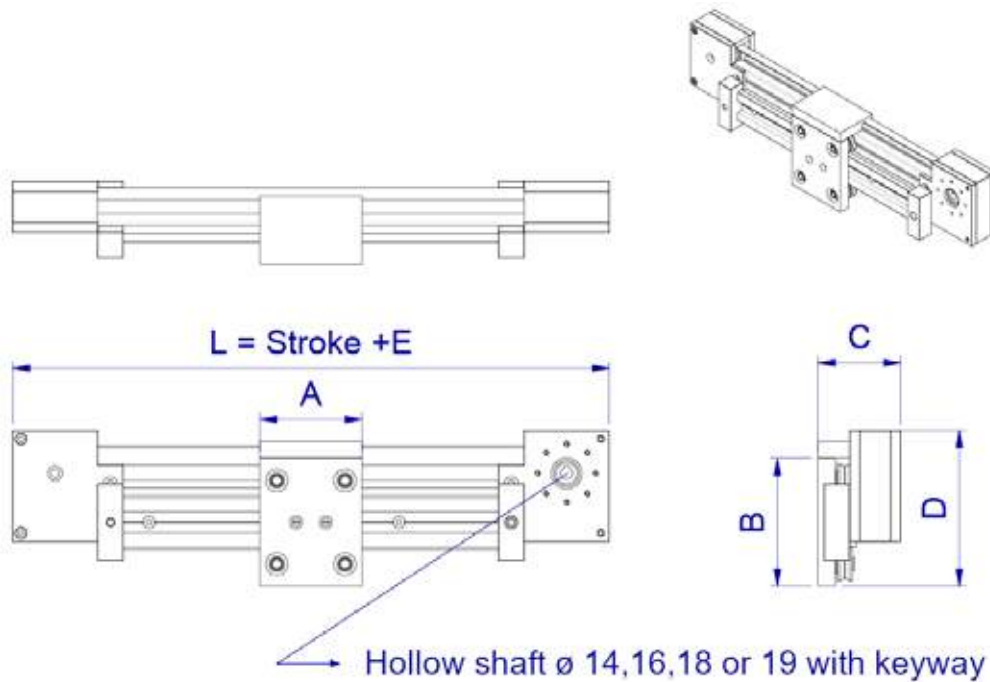

Type	A	B	C	D	E
C 10-S1	120	150	97	182,5	380
C 12-S1	150	180	103	200	410
C 16-S1	180	200	114,5	215	440

# LTC SERIES

## DIMENSIONS

### DIMENSIONS LTC-TR-C10-S2

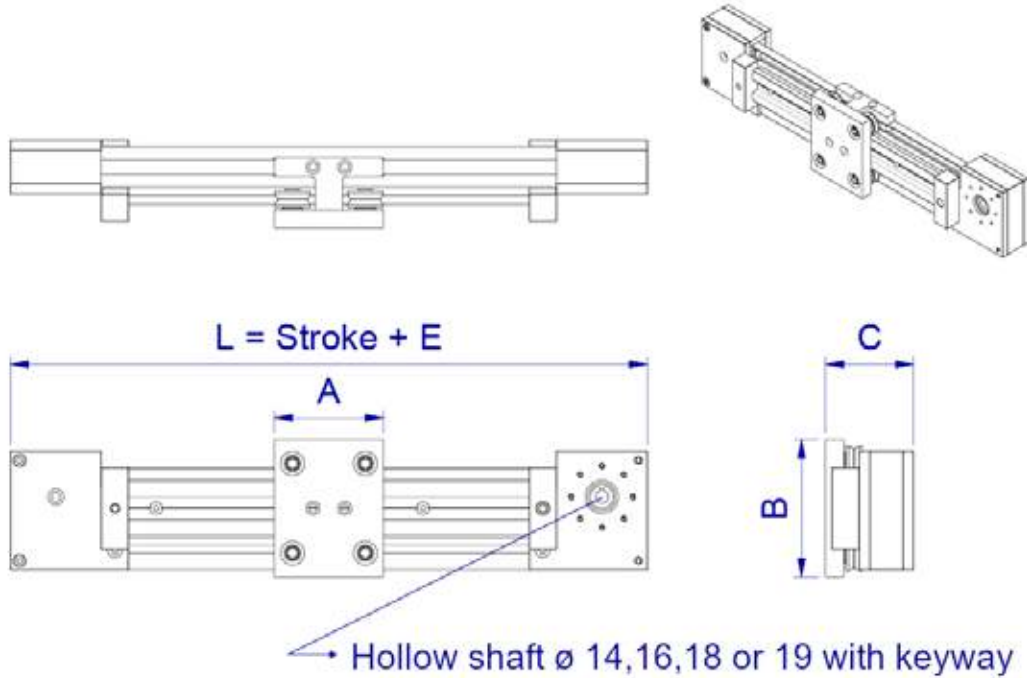

Type	A	B	C	D	E
C 10-S2	120	150	97	-	380
C 12-S2	150	180	103	-	410
C 16-S2	180	200	114,5	-	440

### DIMENSIONS LTC-TR-G20

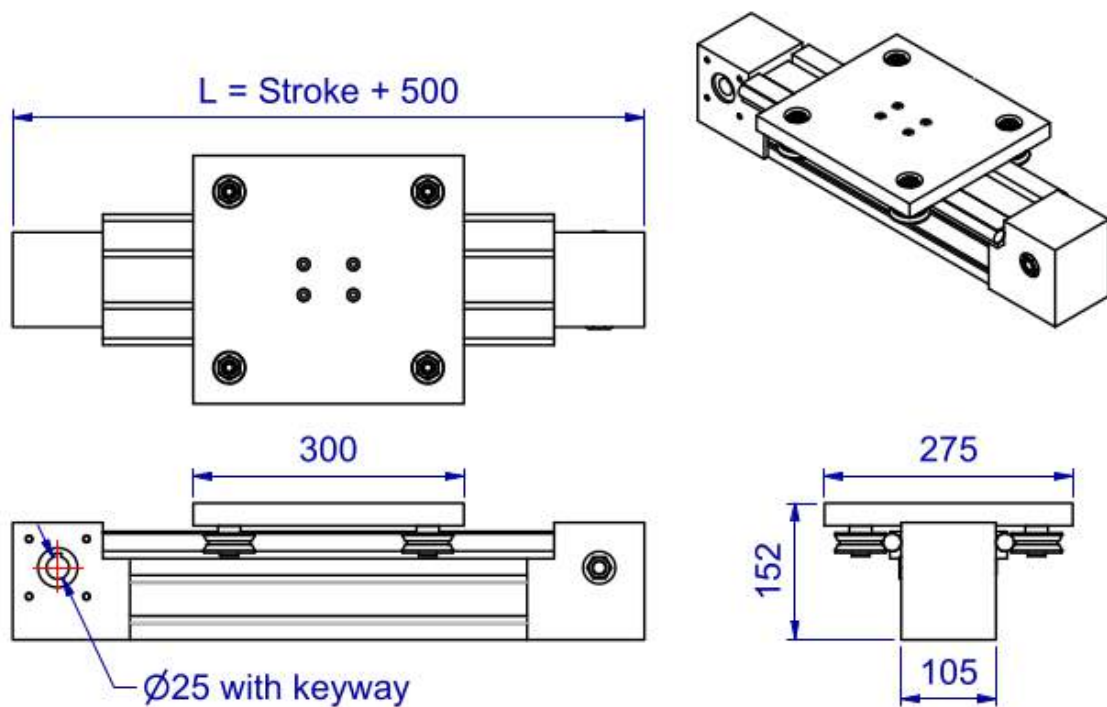

# LTC-TR-C

## ACCESSORIES

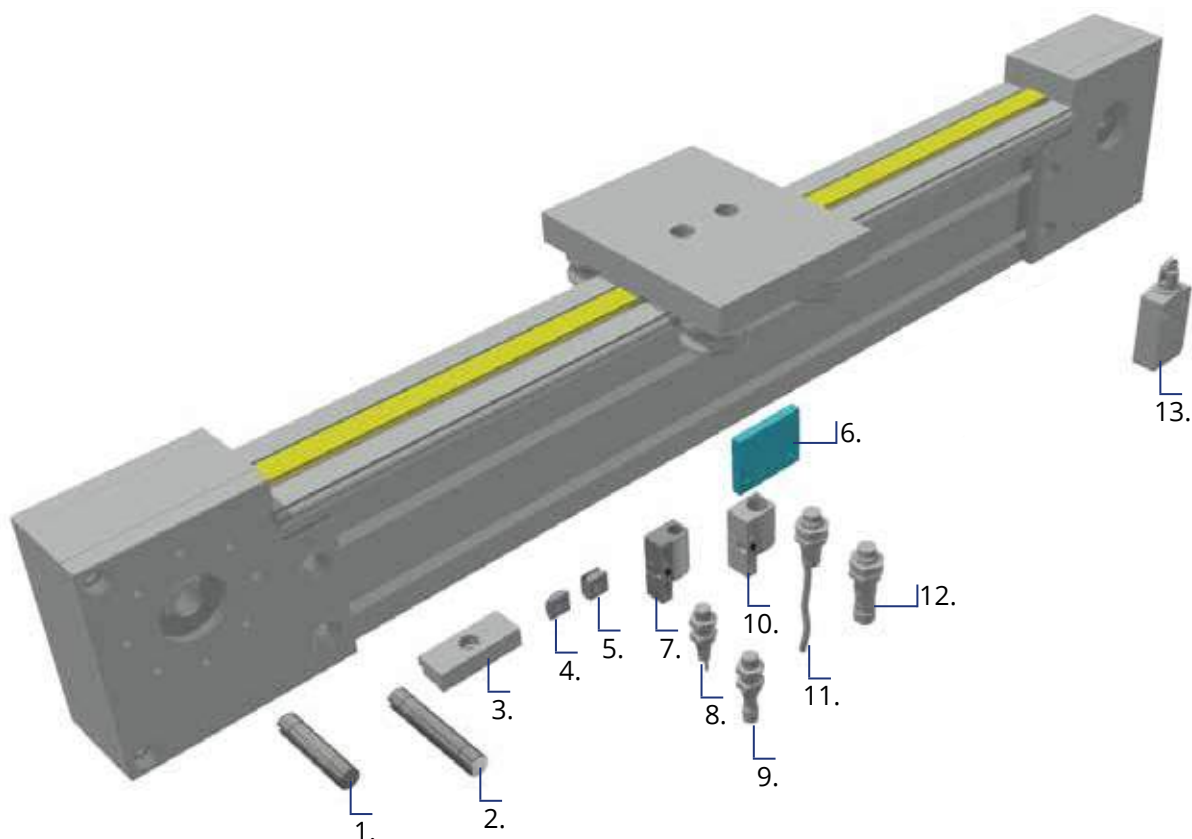

1	LTC-SH-14	Motor shaft 1 side
2	LTC-SH-14D	Motor shaft 2 sides
3	21.1027	Clamping bracket
4	21.1347	Square nut M5
4	21.1330	Square nut M6
4	21.1351	Square nut M8
5	21.1347F	Square nut with Fix M5
5	21.1330F	Square nut with Fix M6
5	21.1351F	Square nut with Fix M8
6	LTC45-SH-XS	Bracket for Telem. bracket
7	XSZB108	Bracket for M8 sensor
8	XS05B1PAL2	M8 inductive sensor-cable
9	XS508B1PAM8	M8 inductive sensor-M8
10	XSZB112	Bracket for M12 sensor
11	XS212b4pal	M12 inductive sensor-cable
12	XS212b4pbm	M12 inductive sensor-M8
13	XCMD2102L	Switch with roll

# CUSTOMIZED LINEAR UNITS

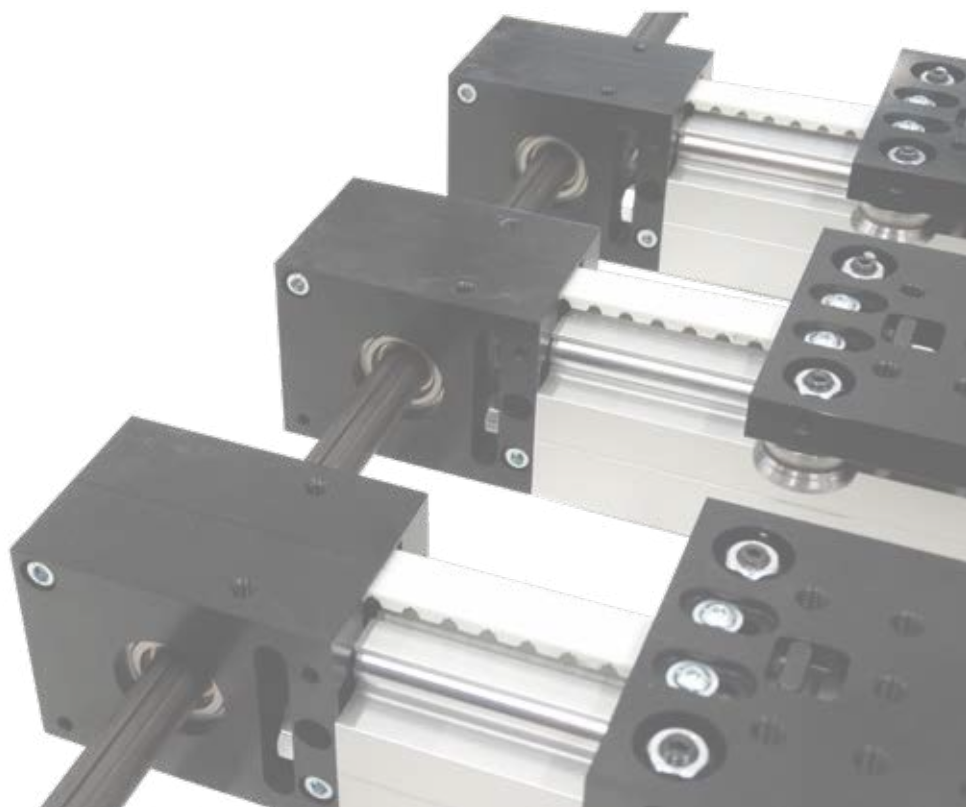

# EXAMPLES OF CUSTOMIZED LINEAR UNITS

## LT88

### **Customer's wishes**

LT50-TR-G8 unit but with no visible cable chain. Chain should be inside a profile together with the guide and belt.

### **Almotion**

Engineering designed two new aluminum profiles and mounting brackets for the application.

### **Solution**

Customer now has a 'plug & play' and optical handsome unit. Not only cost reduction due to the less components, also no more assembling in-house.



## LT60ZLMS

### **Customer's wishes**

LT60S unit but with carriage dimensions fully compatible with a existing brand.

### **Almotion**

Designed new carriage.

### **Solution**

Customer now can interchange our units with the old units without changes.



# EXAMPLES OF CUSTOMIZED LINEAR UNITS

## LT60-2B

### **Customer's wishes**

Two timing belts inside new profile of max, 60 mm wide.

### **Almotion**

Engineering designed a aluminum profile and special end caps with two pulleys per end.

### **Solution**

Customer only has to mount one single unit instead of two and this unit is very compact.

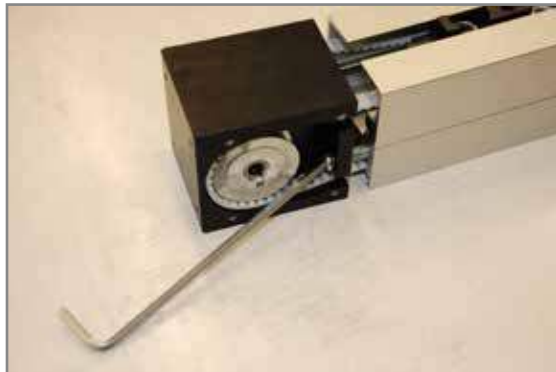
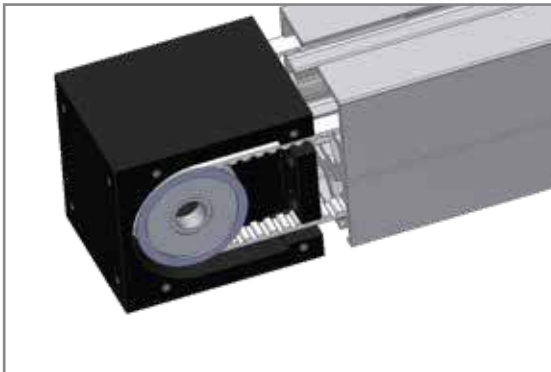

## LTO

### **Customer wishes**

Light weight X-Z application with the motors fixed on the machine frame.

### **Almotion**

Due to the specifications possibilities, known principals ('Omega' construction from the LT2 series) were brought onto the table. Almotion did the engineering so the customer would not only have a solution, they also save valuable engineering capacity.

### **Solution**

An 'Omega' construction with standard LT55 end caps and light weight rail guides from 'FRANKE', all assembled on 40 x 80 mm and 80 x 120 mm profiles. Due to the Omega construction both motors are fixed on the X-axis instead of the Z-axis.

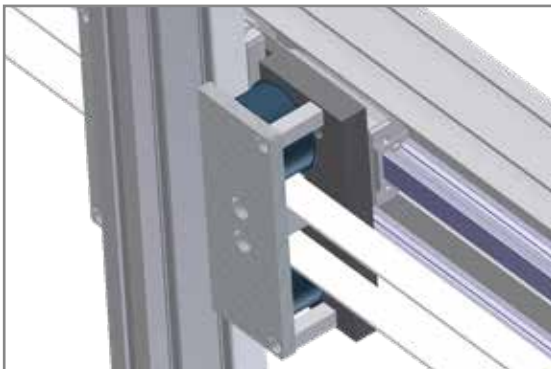

# SPECIFICATIONS OF APPLICATION

Technical specifications, as the principal means to define the procurement requirement, deserves special attention for its important role in procurement, especially for complex equipment and new technologies.

In short, the specification is the 'heart' of the procurement transaction as it:

- Defines your needs and requirements
- Tells you what to procure
- Establishes the quality standard against which bid evaluation, inspection, tests and quality checks are made

It is important to keep in mind the difficulties that will arise if there are attempts to change the specifications after the document has been published and received by us. Often, ill-prepared technical specifications only come to light when concerns are raised and point out some inconsistencies, which of course is only possible after receiving the document.



## 1. Description of the project

--

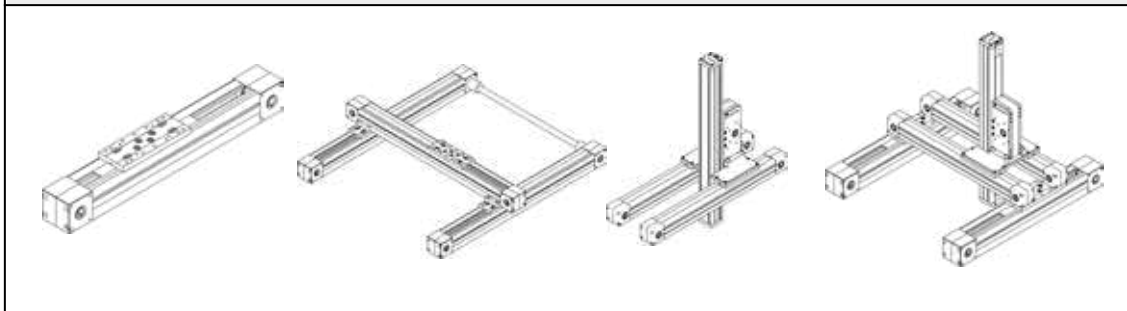
## 2. Description of the axis

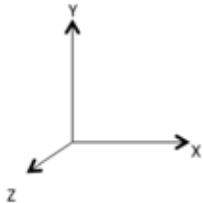

# SPECIFICATIONS OF APPLICATION

3. Sketch of the application						
						
4. Requirement information						
<input type="checkbox"/> Single application			<input type="checkbox"/> Technical improvement			
<input type="checkbox"/> Series, quantity per year: .....			<input type="checkbox"/> Reduction of expenses			
<input type="checkbox"/> New construction			<input type="checkbox"/> .....			
5. Information about the axis / system configuration						
	Payload		[kg]	X-axis horiz.	Y-axis horiz.	Z-axis vertic.
	Moment arm to center of mass	X-direction	[mm]			
		Y-direction	[mm]			
		Z-direction	[mm]			
	Table part			<input type="checkbox"/> Table	<input type="checkbox"/> Table	<input type="checkbox"/> Table
Frame (main part)			<input type="checkbox"/> Frame	<input type="checkbox"/> Frame	<input type="checkbox"/> Frame	
<b>Basis information</b>	Useful stroke		[mm]			
<b>Load</b>	Additional force (e.g. process force)		[mm]			
	Force direction of the add. force (axis & direction e.g. Z+)					
<b>Dynamics</b>	Velocity v <sub>max</sub>		[m/s]			
	Acceleration a <sub>max</sub>		[m/s <sup>2</sup> ]			
<b>End switch</b>				<input type="checkbox"/> Yes	<input type="checkbox"/> No	
<b>Accuracy</b>	Repeatability		[mm]			
<b>Environmental conditions</b>	Temperature		[°C]			
	Humidity		[%]			
	Dirt, interference fields, site					

# APPENDIX

## Timing belt or toothed belt

Timing belts AT5 and AT10 are manufactured of wear resistant polyurethane and high tensile steel cords. High quality materials combined form the basis for dimensionally stable and high resistance polyurethane timing belts. Polyurethane timing belts have a very high span rigidity. No post-elongation of the tension cords is to be expected in continuous operation.



The timing belts are temperature resistant with ambient temperatures from -30°C to +80°C. These polyurethane timing belts are suitable for the transmission of high torques as well as the precise positioning and transport of various goods. The timing belts are available in many different versions like food applications and very flexible or reinforced versions.

*If you need more information or calculations regarding the timing belt, please contact us.*

## Linear guideways

Our linear units are designed in a way that it is possible to mount most brands of linear guideways. Normally we can assemble the brand that you prefer. Linear guideways can be classified into non-interchangeable types. The sizes are identical. The main difference is that the interchangeable blocks and rails can be freely exchanged. Because of dimensional control, the interchangeable type linear guideway is a perfect choice for the client when rails do not need to be paired for an axis.

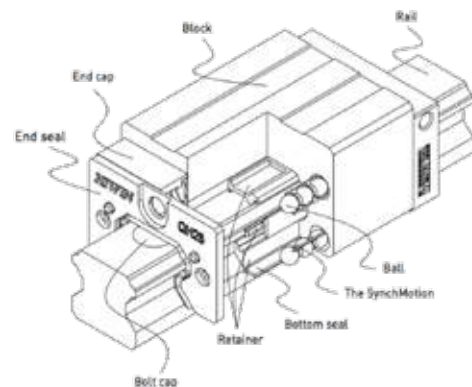

*If you need more information or calculations regarding linear guideways, please contact us.*

## Mounting and alignment

The linear unit must always be factened on clean and level surfaces.

A linear unit that is used in a single-axis configuration need only to comply with the standard mounting requirements. Alignment of linear units in multi-axis configurations is more difficult. Especially if they must work together. To ensure maximum life and performance must comply with the requirements of alignment and squareness of the linear units that participate in the configuration.

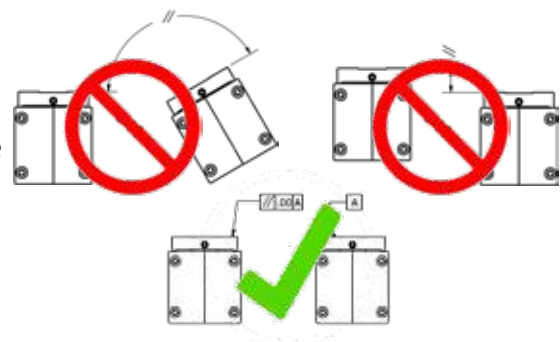

*If you need more information regarding mounting and alignment, please contact us.*

# NOTES

# NOTES

# YOUR SUPPORT FOR SOLUTIONS WITH LINEAR UNITS

THE UNIT RANGE ALSO INCLUDES VARIOUS MOUNTINGS PARTS TO HAVE EASY ASSEMBLING OF UNIT INTO A FULL CONFIGURATION. CUSTOM-FIT BRACKETS CAN BE PRODUCED.



Almotion team of technical specialists can assist in designing the linear units into your machine / construction.

Worldwide support for linear units.  
Please contact us for your local  
technical assistant.

**ALMOTION**<sup>®</sup>

**Almotion bv**

Nijverheidsweg 14  
6662 NG ELST (Gld)  
The Netherlands  
T : 0031 85 0491 777  
E : info@almotion.nl  
I : www.almotion.nl  
I : www.linearmotion.nl  
I : www.lineairegeleiding.nl



**ISO 16016:2000**

Technical product documentation - Protection notices for restricting the use of documents and products.

04-2023DRU

Errors and changes without notice.