

ROLLON®

BY TIMKEN

Compact Rail

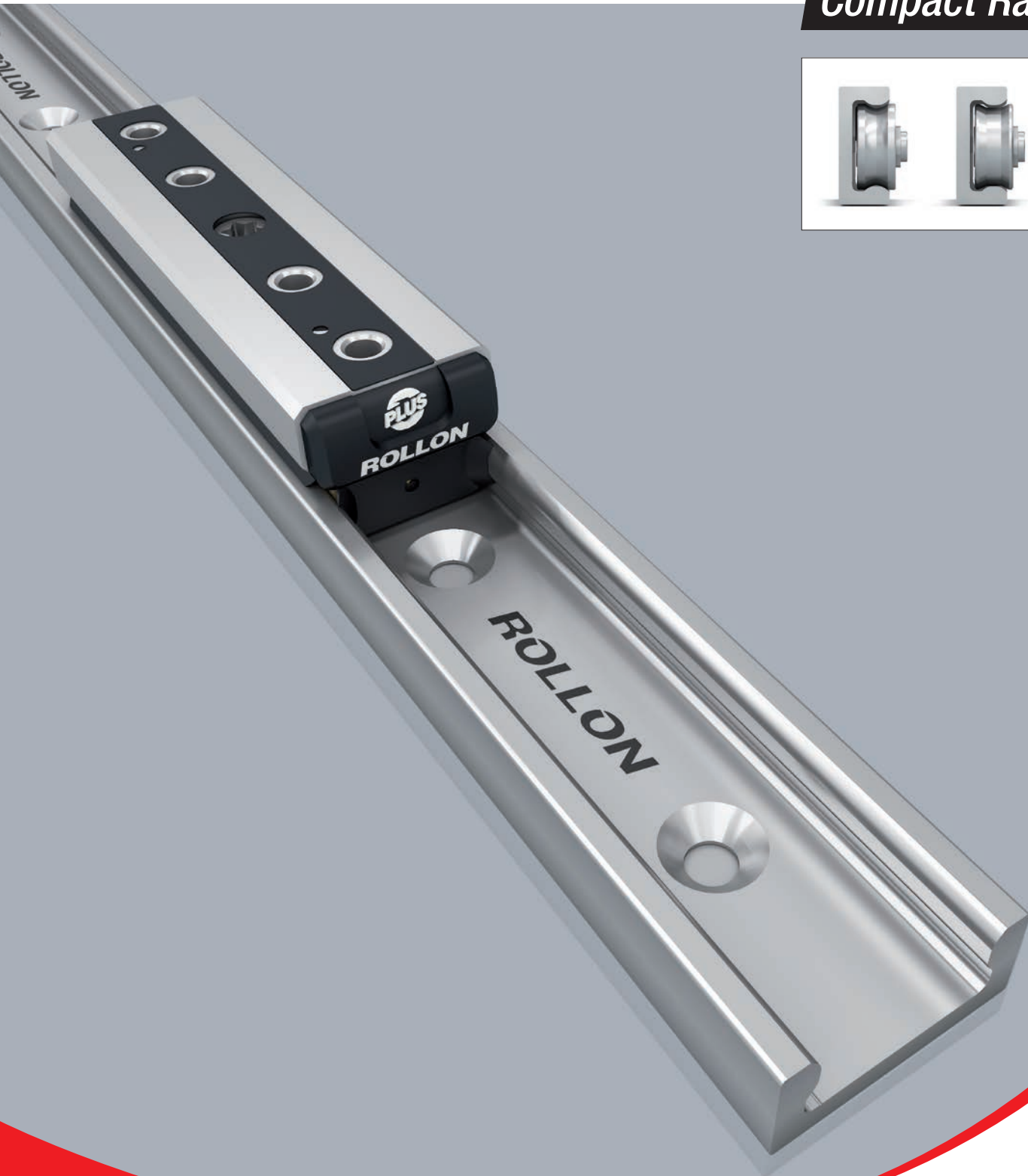

Product explanation



> The newly designed Rollon guide with double row ball bearings for higher load capacities.



Fig. 1

Featuring double row ball bearings, new rigid rails with convex raceways and new robust steel sliders with longitudinal protection and floating wipers, Compact Rail Plus has been designed for the most demanding applications in terms of load capacities, dynamics and work environment. All while maintaining the self-aligning capabilities that make this product family unique.

The rails are made of cold drawn carbon steel, zinc-plated for sizes 28 and 43 and hardened with Rollon-Nox patented process for size 18 (nitriding and black oxidation). Other treatments for higher corrosion resistance are available as an option. For sizes 28 and 43, raceways are induction hardened and ground. The sliders are available in four versions: guiding slider; floating slider; extra-floating slider and rotating slider. Combining two rails with different sliders makes it possible to create self-aligning systems that can compensate misalignment errors on two planes: radial up to $\pm 1.3^\circ$ and axial up to 3.5 mm.

The most important characteristics:

- High radial and axial load capacity
- High rigidity
- Robust steel slider with longitudinal protection and floating wipers
- Self-aligning in two planes
- Induction hardened and ground raceways (size 28 and 43)
- Nitriding and black oxidation and polished raceways (size 18)
- Protected for dirty environments
- High operating speeds
- Wide temperature range
- Two ways to adjust the slider in the guide rail
- Different anticorrosion treatments available for rails and slider bodies

Preferred areas of application:

- Cutting machines
- Medical technology
- Packaging machines
- Photographic lighting equipment
- Construction and machine technology (doors, protective covers)
- Robots and manipulators
- Automation
- Handling

Rail with convex raceways

Rails are made of cold-drawn carbon steel and feature a c-shaped cross-section with interior convex raceways. The rail shape allows protection from accidental bumps and other damages that might occur during usage.

For sizes 28 and 43, the raceways are induction hardened and fine ground and the rail is zinc-plated. Other treatments are available for higher corrosion resistance, these include: Rollon Aloy, Rollon E-coating and nickel plating. For size 18, the rail is treated with Rollon-Nox nitriding and oxidation process that provides a fine black color to the entire rail. Other anticorrosion treatments are not available.

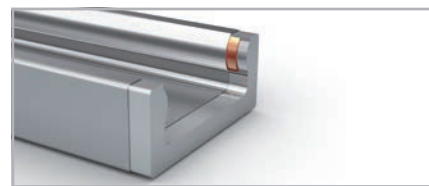

Fig. 2



Fig. 3

R-slider

Robust zinc plated steel slider with sealed double row ball bearing rollers, self-centering heads with wipers, longitudinal seals to protect the internal components and a top sealing strip to prevent accidental tampering of the fixed rollers. The slider body is accurately finished with matte longitudinal edge chamfer and a shining ground flat surface. It is available for all sizes, configurable with up to six rollers depending on the load requirement. Four versions are available to allow different floating capacities and create self-aligning systems: RV guiding slider, RP floating slider, RU extra-floating slider and RA rotating slider.



Fig. 4

RD-slider

Constructed as the R-slider with mounting holes parallel to the direction of preferred loading. It is available for sizes 28 and 43, with three or five rollers, depending on load case and load direction set with the corresponding configuration.



Fig. 5

Self-alignment system: V+P/U

The combination of two rails, one featuring a RV guiding slider and one featuring a RP floating slider or RU extra-floating slider, creates a system that allows to compensate large axial misalignment errors.



Fig. 6

Self-alignment system: A+P/U

The combination of two rails, one featuring a RA rotating slider and one featuring a RP floating slider or RU extra-floating slider, creates a system that allows to compensate misalignment errors on two planes: axial and radial.

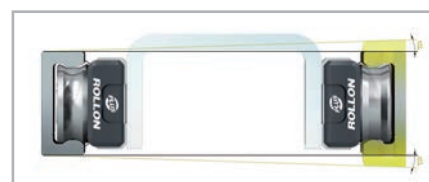

Fig. 7

Rollers

The precision rollers have double row ball bearings to provide high load capacities in both radial and axial direction. All rollers are equipped with splash-proof plastic seal (2RS). They are available in three versions: guiding rollers with two contact points on the raceway; floating rollers with one contact point and two lateral shoulders to limit the axial floating; extra-floating rollers with completely flat outer ring for total excursion. All rollers can also be ordered individually, and for size 28 and 43 it is available the stainless steel version.

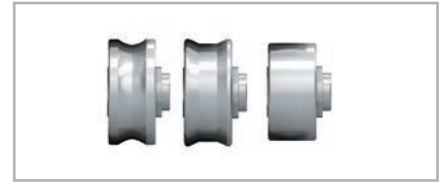

Fig. 8

Wipers

The slider heads are equipped with special slow release felt pads and are free to rotate with respect to the slider body, so that the felts are always in contact with the raceways to ensure a perfect lubrication. The felts can be grased through a dedicated oil refilling access on the front of the head, simply by means of a syringe oiler.



Fig. 9

Alignment fixture

The alignment fixture is used during installation of joined rails in order to precisely align the rails with each other.

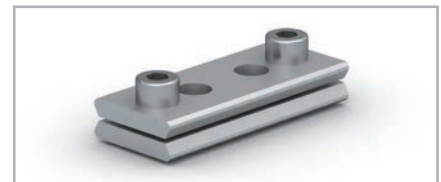

Fig. 10

Technical data

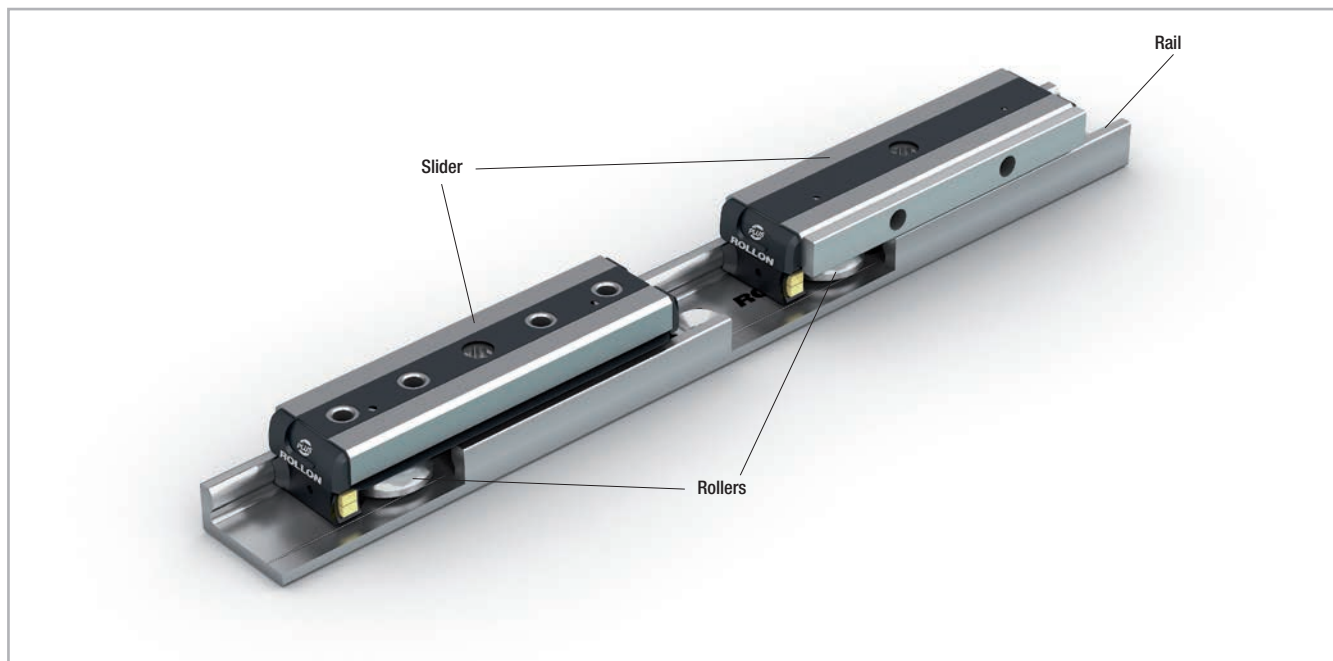

Fig. 11

Performance characteristics:

- Available rail sizes: 18, 28, 43
- Max. operating speed: 7 m/s (276 in/s) (depending on application)
- Max. acceleration: 15m/s² (590.55 in/s²) (depending on application)
- Max. radial load capacity: 10,800 N (per slider)
- Temperature range: -20 °C to +120 °C (-4 °F to +248 °F)
briefly up to max. +150 °C (+302 °F)
- Available rail lengths from 160 mm to 3,600 mm (6.3 in to 142 in)
in 80-mm increments (3.15 in), longer single rails up to max.
4,080 mm (160.6 in) on request for sizes 28 and 43.
- Rollers material: steel 100Cr6 (also available stainless steel AISI 440)
- Roller pins lubricated for life
- Roller seal/shield: 2RS (splash-proof)
- In sizes 28 and 43 rails and slider bodies are standard zinc-plated
according to ISO 2081, raceways are induction hardened and ground.
- In size 18 rails are hardened with Rollon-Nox treatment of deep nitriding
and black oxidation and slider bodies are standard zinc-plated
according to ISO 2081.
- Rail material of rails size 28-43: cold-drawn carbon steel CF53
- Rail material of rails size 18: cold-drawn carbon steel 20MnCr5

Notes:

- The sliders are equipped with rollers that are in alternating contact
with both sides of the raceway. Markings on the body around the roller
pins indicate correct arrangement of the rollers to the external load
- With a simple adjustment of the eccentric rollers, the desired clearance
or preload on the rail and slider can be set (see pg. CR-35)
- Rails in joined design are available for longer transverse distances
(see pg. CR-43).
- Screws of property class 10.9 must be used
- When mounting the rails, it is crucial to ensure that the mounting holes
in the structure are properly chamfered (see pg. CR-34 tab. 59)
- The general illustrations show R-sliders as an example
- For rollers size 28 and 43 it is available the stainless steel version
(see pg. CR-18).

> Configurations and behavior of the slider under yawing moment M_z

Individual slider under M_z moment load

When an overhanging load in an application with a single slider per rail causes an M_z moment in one direction, a 4 to 6 roller Compact Rail slider is available. These sliders are available in both configuration A and B in regards to the roller arrangement to counter the acting M_z moment load. The moment capacity of these sliders in the M_z -direction varies significantly through spacing L_1 and L_2 in accordance with the direction of rotation of M_z .

Especially in the use of two parallel rails, it is extremely important to pay attention to the correct combination of the slider configuration A and B, in order to use the maximum load capacities of the slider. The diagrams below illustrate this concept of the A and B configuration for sliders with 4 and 6 rollers. The maximum allowable M_z -moment is identical in both directions for all 3 and 5 roller sliders.

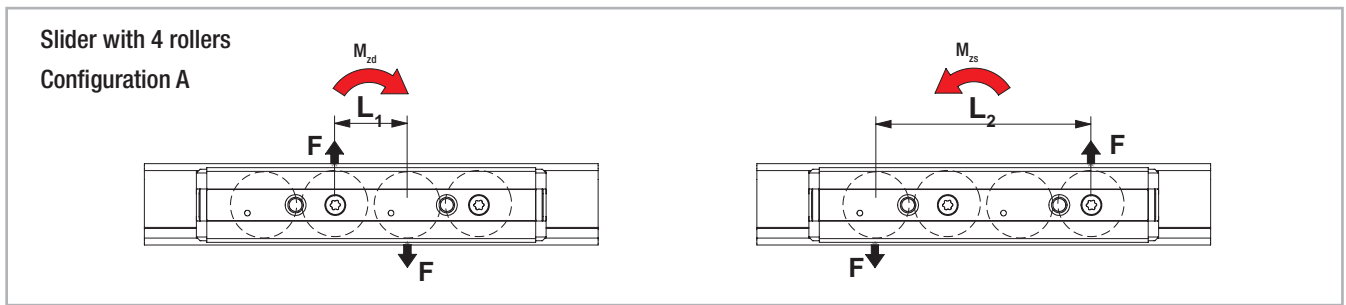

Fig. 12

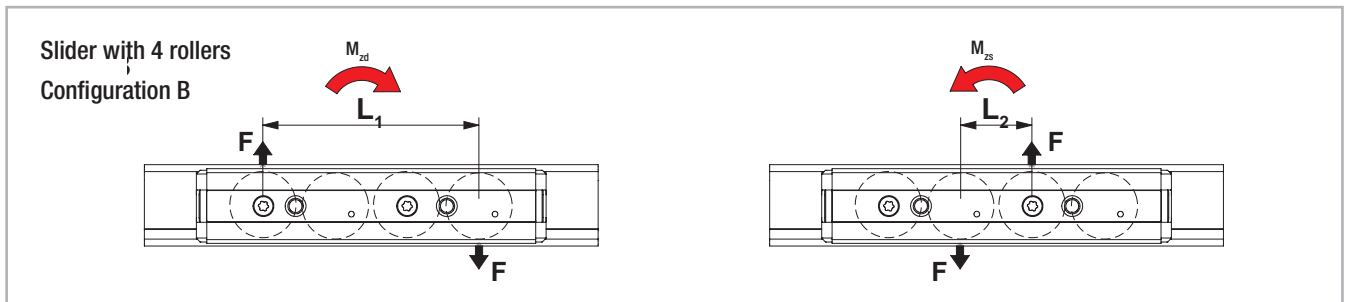

Fig. 13

Two sliders under M_z moment load

When an overhanging load acts on an application with two sliders per rail and causes an M_z -moment in one direction, different support reactions occur on the two sliders. For this reason, an optimal arrangement of slider configurations must be achieved to reach the maximum load capacities. In practice, when using R-sliders with 3 or 5 rollers, the two sliders must be installed rotated by 180° so that the slider is always loaded on the side with the highest number of rollers.

For an even number of rollers this has no effect. The RD-sliders with installation option from above or below cannot be installed due to the position of the rollers in reference to the installation side, therefore they are available in the configurations A and B (see fig. 15).

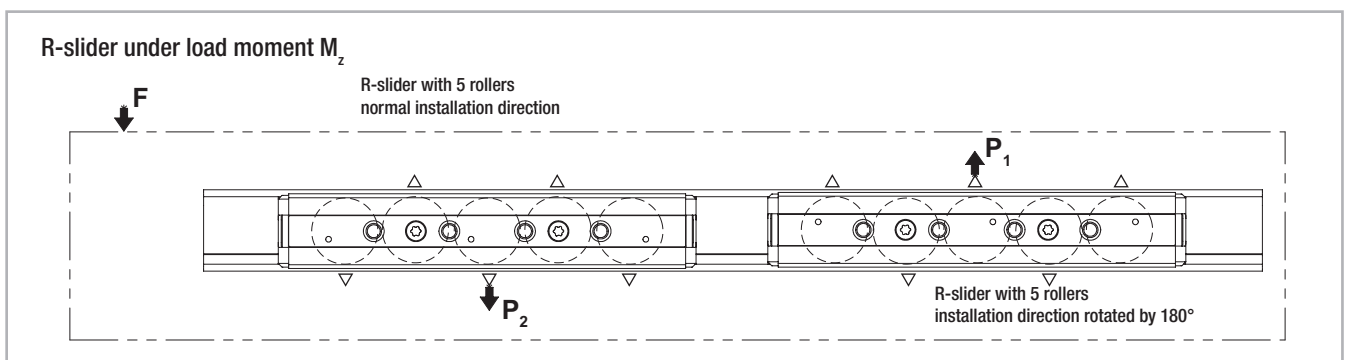
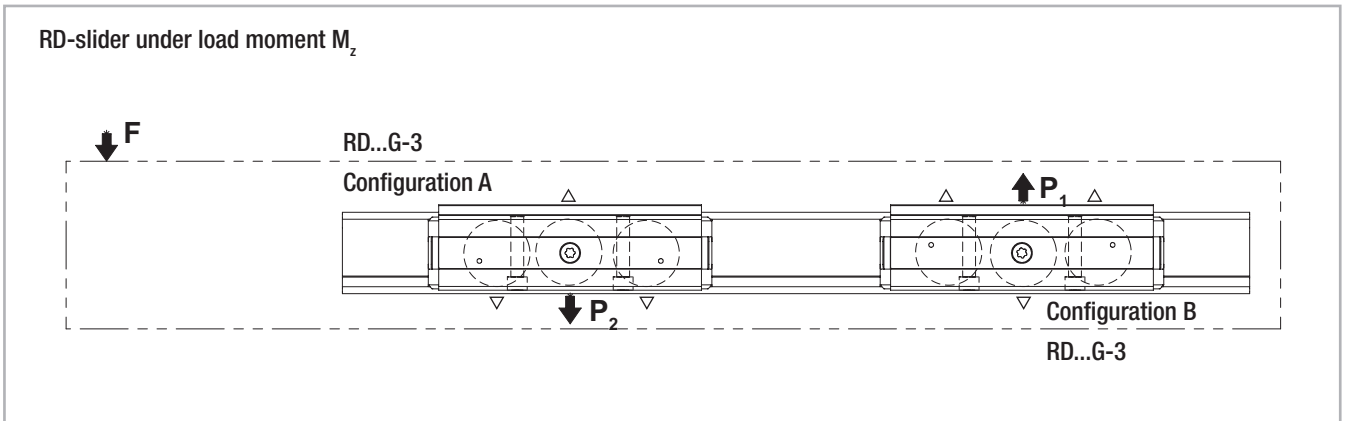

Fig. 14



Configuration not possible for sliders RDA.

Fig. 15

Slider configurations for various load cases

Arrangement DS

This is the recommended arrangement for use of two sliders under M_z -moment when using one rail. Also see previous page: Two sliders under M_z moment load.

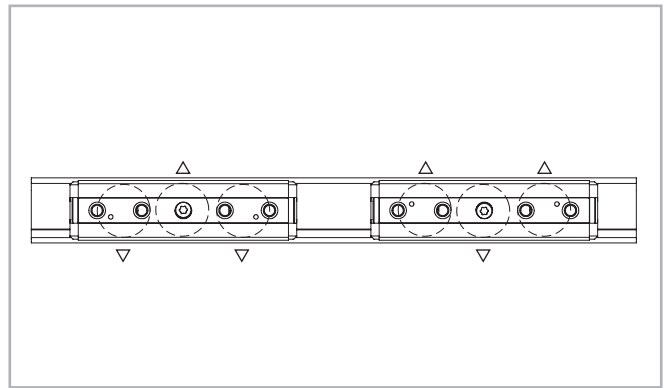

Fig. 16

Arrangement DD

When using a pair of guide rails with two sliders each under M_z moment load, the second system should be designed in arrangement DD. This results in the following combination: one guide rail with two sliders in arrangement DS and the other guide rail with 2 sliders in arrangement DD. This allows even load and moment distribution between the two parallel rails.

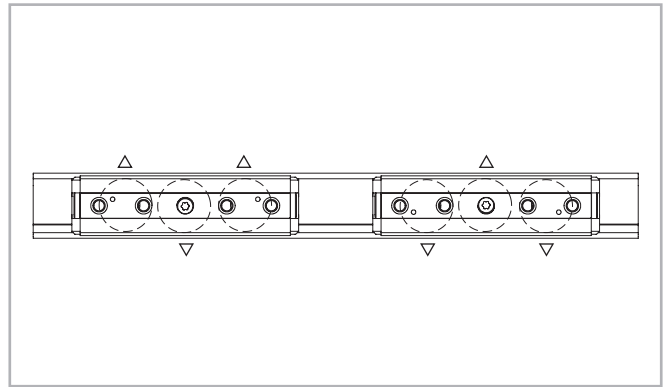

Fig. 17

Arrangement DA

Standard arrangement if no other information is given. This arrangement is recommended if the load point is located within the two outside points of the sliders.

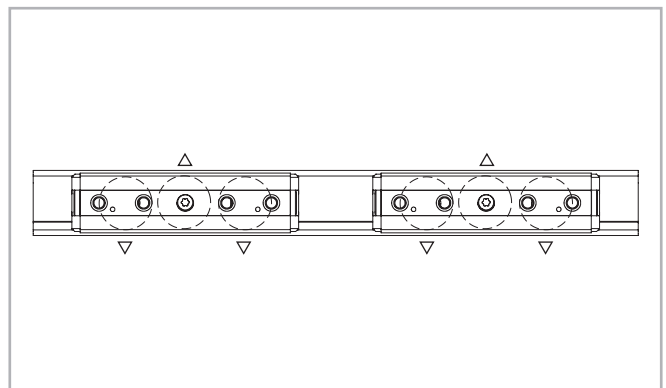

Fig. 18

> Load capacities

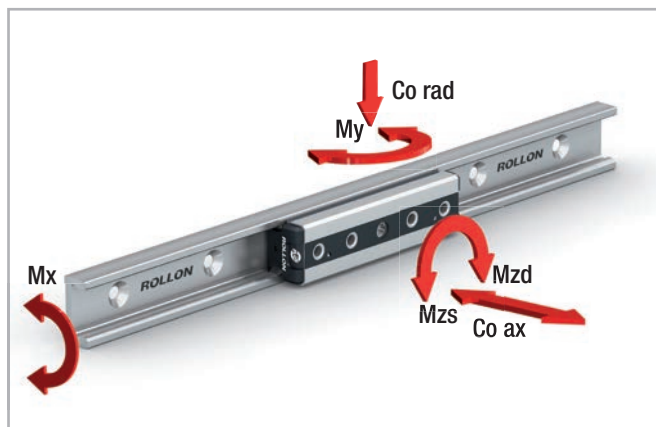

Fig. 19

The load capacities in the following table apply for one slider.

The functional characteristic is related to the nominal floating capacity, for more information see pg. CR-22, CR-23.

Type	Number of rollers	Load capacities and moments							Weight [kg]
		C [N]	Co _{rad} [N]	Co _{ax} [N]	M _x [Nm]	M _y [Nm]	M _z [Nm]		
							M _{zd}	M _{zs}	
RVG18-3	3	3300	1600	690	3	8.3	14.4	14.4	0.055
RVG18-4A	4	3300	1600	920	6	13.8	16	48	0.073
RVG18-4B	4	3300	1600	920	6	13.8	48	16	0.073
RVG18-5	5	4455	2160	1150	6	18.4	48	48	0.087
RVG18-6A	6	4455	2160	1380	9	23	48	80	0.105
RVG18-6B	6	4455	2160	1380	9	23	80	48	0.105
RAG18-3	3	3300	1600	460	0	8.3	14.4	14.4	0.055
RAG18-4A	4	3300	1600	460	0	13.8	16	48	0.073
RAG18-4B	4	3300	1600	460	0	13.8	48	16	0.073
RAG18-5	5	4455	2160	690	0	18.4	48	48	0.087
RAG18-6A	6	4455	2160	690	0	23	48	80	0.105
RAG18-6B	6	4455	2160	690	0	23	80	48	0.105
RPG18-3	3	3300	1600	0	0	0	14.4	14.4	0.055
RPG18-4A	4	3300	1600	0	0	0	16	48	0.073
RPG18-4B	4	3300	1600	0	0	0	48	16	0.073
RPG18-5	5	4455	2160	0	0	0	48	48	0.087
RPG18-6A	6	4455	2160	0	0	0	48	80	0.105
RPG18-6B	6	4455	2160	0	0	0	80	48	0.105
RUG18-3	3	2300	1120	0	0	0	10.1	10.1	0.052
RUG18-4A	4	2300	1120	0	0	0	11.2	33.6	0.070
RUG18-4B	4	2330	1120	0	0	0	33.6	11.2	0.070
RUG18-5	5	3105	1512	0	0	0	33.6	33.6	0.084
RUG18-6A	6	3105	1512	0	0	0	33.6	56	0.1
RUG18-6B	6	3105	1512	0	0	0	56	33.6	0.1

Tab. 1

Type	Number of rollers	Load capacities and moments							Weight [kg]
		C [N]	Co _{rad} [N]	Co _{ax} [N]	M _x [Nm]	M _y [Nm]	M _z [Nm]		
							M _{zd}	M _{zs}	
RV28G-3	3	6000	3200	1380	9.2	25.3	44	44	0.24
RV28G-4A	4	6000	3200	1840	18.4	34.5	40	120	0.29
RV28G-4B	4	6000	3200	1840	18.4	34.5	120	40	0.29
RV28G-5	5	8100	4320	2300	18.4	46	120	120	0.36
RV28G-6A	6	8100	4320	2760	27.6	57.5	120	200	0.4
RV28G-6B	6	8100	4320	2760	27.6	57.5	200	120	0.4
RA28G-3	3	6000	3200	920	0	25.3	44	44	0.24
RA28G-4A	4	6000	3200	920	0	34.5	40	120	0.29
RA28G-4B	4	6000	3200	920	0	34.5	120	40	0.29
RA28G-5	5	8100	4320	1380	0	46	120	120	0.36
RA28G-6A	6	8100	4320	1380	0	57.5	120	200	0.4
RA28G-6B	6	8100	4320	1380	0	57.5	200	120	0.4
RP28G-3	3	6000	3200	0	0	0	44	44	0.24
RP28G-4A	4	6000	3200	0	0	0	40	120	0.29
RP28G-4B	4	6000	3200	0	0	0	120	40	0.29
RP28G-5	5	8100	4320	0	0	0	120	120	0.36
RP28G-6A	6	8100	4320	0	0	0	120	200	0.4
RP28G-6B	6	8100	4320	0	0	0	200	120	0.4
RU28G-3	3	4200	2240	0	0	0	30.8	30.8	0.24
RU28G-4A	4	4200	2240	0	0	0	28	84	0.27
RU28G-4B	4	4200	2240	0	0	0	84	28	0.27
RU28G-5	5	5670	3024	0	0	0	84	84	0.33
RU28G-6A	6	5670	3024	0	0	0	84	140	0.39
RU28G-6B	6	5670	3024	0	0	0	140	84	0.39
RDV28G-3A	3	6000	3200	1380	9.2	25.3	44	44	0.28
RDV28G-3B	3	6000	3200	1380	9.2	25.3	44	44	0.28
RDV28G-5A	5	8100	4320	2300	18.4	46	120	120	0.41
RDV28G-5B	5	8100	4320	2300	18.4	46	120	120	0.41
RDA28G-3A	3	6000	3200	920	0	25.3	44	44	0.39
RDA28G-3B	3	6000	3200	920	0	25.3	44	44	0.39
RDA28G-5A	5	8100	4320	1380	0	46	120	120	0.41
RDA28G-5B	5	8100	4320	1380	0	46	120	120	0.41
RDP28G-3A	3	6000	3200	0	0	0	44	44	0.39
RDP28G-3B	3	6000	3200	0	0	0	44	44	0.39
RDP28G-5A	5	8100	4320	0	0	0	120	120	0.41
RDP28G-5B	5	8100	4320	0	0	0	120	120	0.41
RDU28G-3A	3	4200	2240	0	0	0	30.8	30.8	0.25
RDU28G-3B	3	4200	2240	0	0	0	30.8	30.8	0.25
RDU28G-5A	5	5670	3024	0	0	0	84	84	0.38
RDU28G-5B	5	5670	3224	0	0	0	84	84	0.38

Tab. 2

Type	Number of rollers	Load capacities and moments							Weight [kg]
		C [N]	Co _{rad} [N]	Co _{ax} [N]	M _x [Nm]	M _y [Nm]	M _z [Nm]		
							M _{zd}	M _{zs}	
RV43G-3	3	15200	8000	3570	36.9	97.6	164	164	0.77
RV43G-4A	4	15200	8000	4760	73.8	135.7	152	456	0.99
RV43G-4B	4	15200	8000	4760	73.8	135.7	456	152	0.99
RV43G-5	5	20520	10800	5950	73.8	195.2	452.4	452.4	1.19
RV43G-6A	6	20520	10800	7140	110.7	224.3	452.4	754	1.42
RV43G-6B	6	20520	10800	7140	110.7	224.3	754	452.4	1.42
RA43G-3	3	15200	8000	2380	0	97.6	164	164	0.77
RA43G-4A	4	15200	8000	2380	0	135.7	152	456	0.99
RA43G-4B	4	15200	8000	2380	0	135.7	456	152	0.99
RA43G-5	5	20520	10800	3570	0	195.2	452.4	452.4	1.19
RA43G-6A	6	20520	10800	3570	0	224.3	452.4	754	1.42
RA43G-6B	6	20520	10800	3570	0	224.3	754	452.4	1.42
RP43G-3	3	15200	8000	0	0	0	164	164	0.77
RP43G-4A	4	15200	8000	0	0	0	152	456	0.99
RP43G-4B	4	15200	8000	0	0	0	456	152	0.99
RP43G-5	5	20520	10800	0	0	0	452.4	452.4	1.19
RP43G-6A	6	20520	10800	0	0	0	452.4	754	1.42
RP43G-6B	6	20520	10800	0	0	0	754	452.4	1.42
RU43G-3	3	11400	5600	0	0	0	114.8	114.8	0.75
RU43G-4A	4	11400	5600	0	0	0	106.4	319.2	0.96
RU43G-4B	4	11400	5600	0	0	0	319.2	106.4	0.96
RU43G-5	5	15390	7560	0	0	0	316.7	316.7	1.16
RU43G-6A	6	15390	7560	0	0	0	316.7	527.8	1.38
RU43G-6B	6	15390	7560	0	0	0	527.8	316.7	1.38
RDV43G-3A	3	15200	8000	3570	36.9	97.6	164	164	0.85
RDV43G-3B	3	15200	8000	3570	36.9	97.6	164	164	0.85
RDV43G-5A	5	20520	10800	5950	74.8	95.2	452.4	452.4	1.3
RDV43G-5B	5	20520	10800	5950	74.8	95.2	452.4	452.4	1.3
RDA43G-3A	3	15200	8000	2380	0	97.6	164	164	0.85
RDA43G-3B	3	15200	8000	2380	0	97.6	164	164	0.85
RDA43G-5A	5	20520	10800	3570	0	95.2	452.4	452.4	1.3
RDA43G-5B	5	20520	10800	3570	0	95.2	452.4	452.4	1.3
RDP43G-3A	3	15200	8000	0	0	0	164	164	0.85
RDP43G-3B	3	15200	8000	0	0	0	164	164	0.85
RDP43G-5A	5	20520	10800	0	0	0	452.4	452.4	1.3
RDP43G-5B	5	20520	10800	0	0	0	452.4	452.4	1.3
RDU43G-3A	3	11400	5600	0	0	0	114.8	114.8	0.83
RDU43G-3B	3	11400	5600	0	0	0	114.8	114.8	0.83
RDU43G-5A	5	15390	7560	0	0	0	316.7	316.7	1.27
RDU43G-5B	5	15390	7560	0	0	0	316.7	316.7	1.27

Tab. 3

Product dimensions 

> TG / TMG -rail

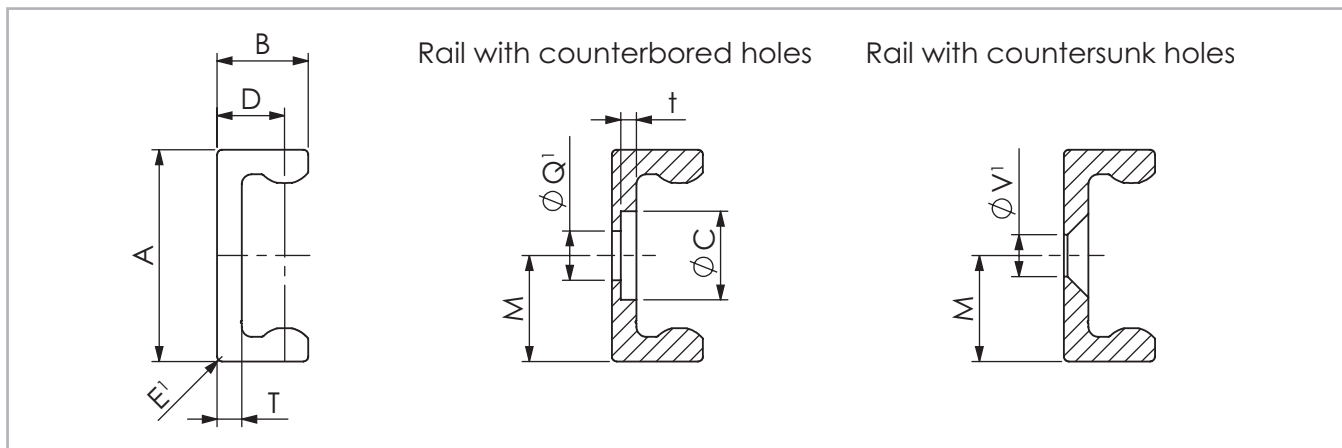

Fig. 20

Q' Fixing holes for Torx® screws with low head (custom design) included in scope of supply
 V' Fixing holes for countersunk head screws according to DIN 7991

Type	Size	A [mm]	B [mm]	M [mm]	E' [mm]	T [mm]	C [mm]	D [mm]	Weight [Kg/m]	t [mm]	Q' [mm]	V' [mm]
TMGC TMGV	18	18	9.5	9	1	2.9	9	7.1	0.68	1.9	M4	M4
TGC TGV	28	28	11.3	14	1	3	11	8.2	1.25	2	M5	M5
	43	43	18.5	21.5	1	5	18	13.7	2.9	3.2	M8	M8

Tab. 4

> Rail length

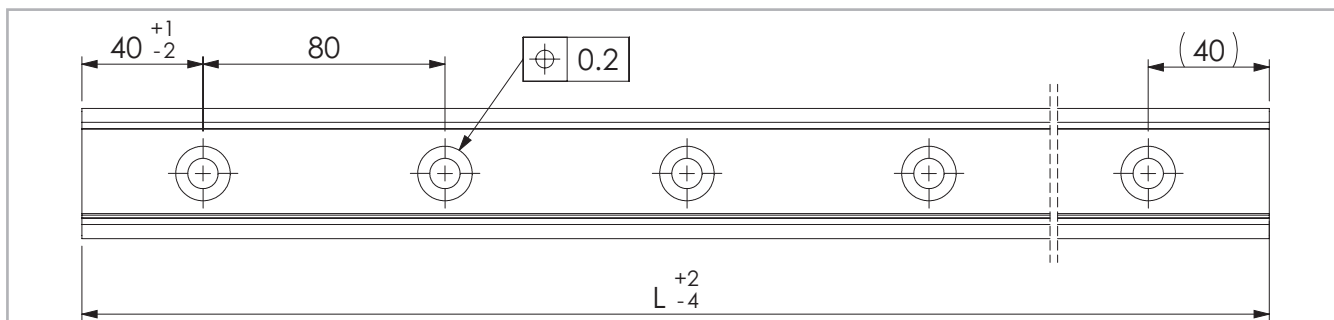

Fig. 21

Type	Size	Min length [mm]	Max length [mm]	Available standard lengths L [mm]
TMGC TMGV	18	240	2960	160 - 240 - 320 - 400 - 480 - 560 - 640 - 720 - 800 - 880 - 960 - 1040 - 1120 - 1200 - 1280 - 1360 - 1440 - 1520 - 1600 - 1680 - 1760 - 1840
TGC TGV	28	160	3600	- 1920 - 2000 - 2080 - 2160 - 2240 - 2320 - 2400 - 2480 - 2560 - 2640
	43	160	3600	- 2720 - 2800 - 2880 - 2960 - 3040 - 3120 - 3200 - 3360 - 3440 - 3520 - 3600

Longer single rails up to max. 4080 mm on request for sizes 28 and 43
 Longer rail systems see pg. CR-43 Joined rails

Tab. 5

> R-version slider

R-series

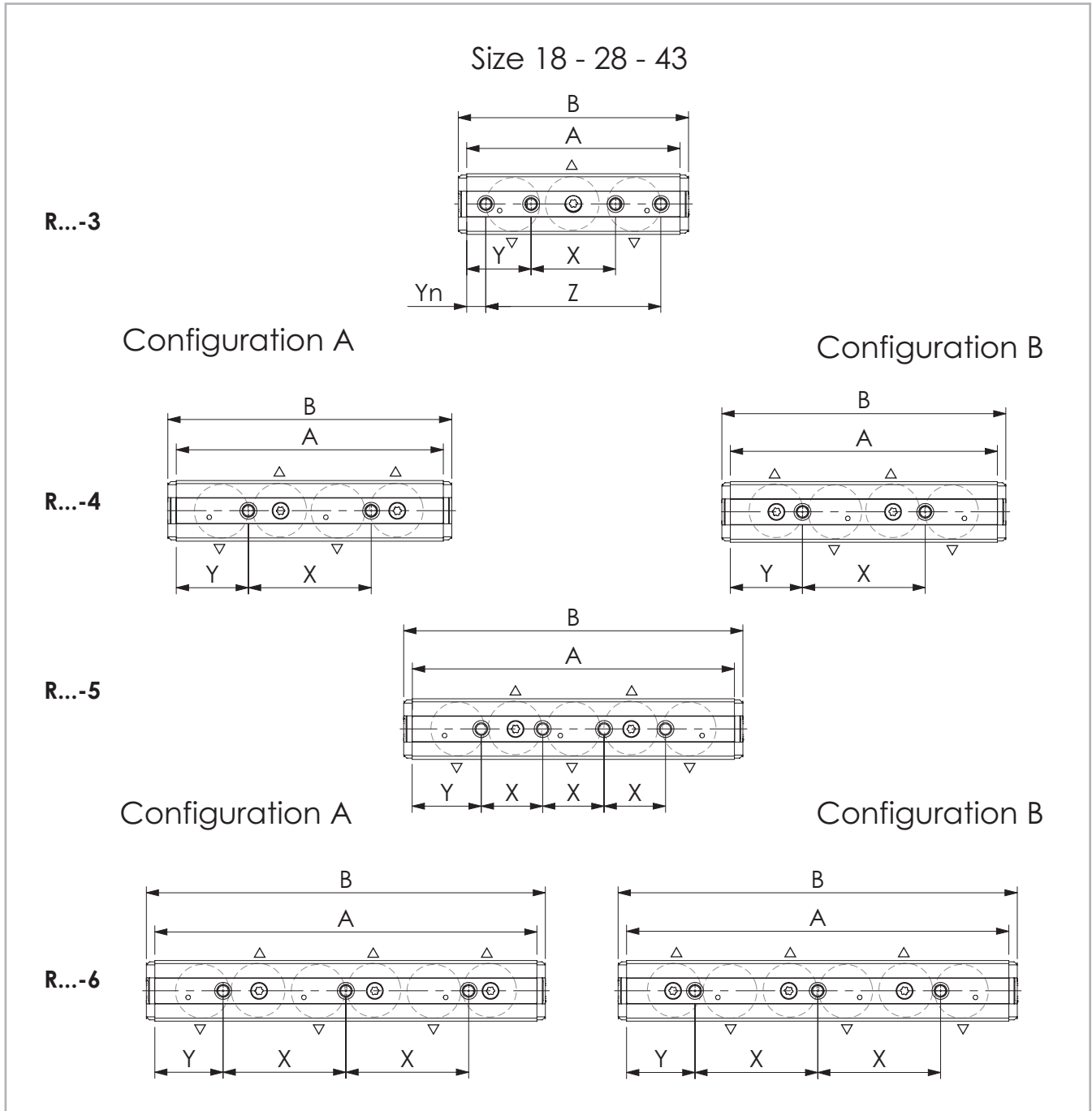

Fig. 22

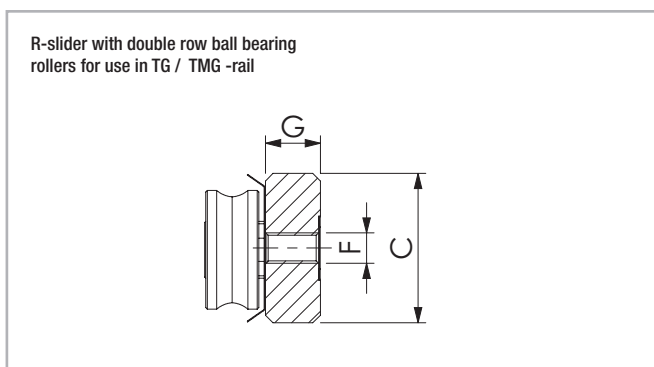

Fig. 23

Type	Size	No. of rollers	A [mm]	B [mm]	C [mm]	G [mm]	F [mm]	X [mm]	Y [mm]	Yn [mm]	Z [mm]	No. of holes
RVG... RAG... RPG... RUG...	18	3	70	78	16	4.8	M5	20	25	9	52	4
		4	92	100				40	26	-	-	2
		5	112	120				20	26	-	-	4
		6	132	140				40	26	-	-	3
RV...G RA...G RP...G RU...G	28	3	97	108	24.9	9.7	M5	35	31	9.5	78	4
		4	117	128				50	33.5	-	-	2
		5	142	153				25	33.5	-	-	4
		6	167	178				50	33.5	-	-	3
	43	3	139	150	39.5	14.5	M8	55	42	12.5	114	4
		4	174	185				80	47	-	-	2
		5	210	221				40	45	-	-	4
		6	249	260				80	44.5	-	-	3

For information about the roller sliders configuration, see pg. CR-22 and CR-23.
For information about the roller type, see pg. CR-18, tab. 10.

Tab. 6

> **RD-version slider**

RD-series

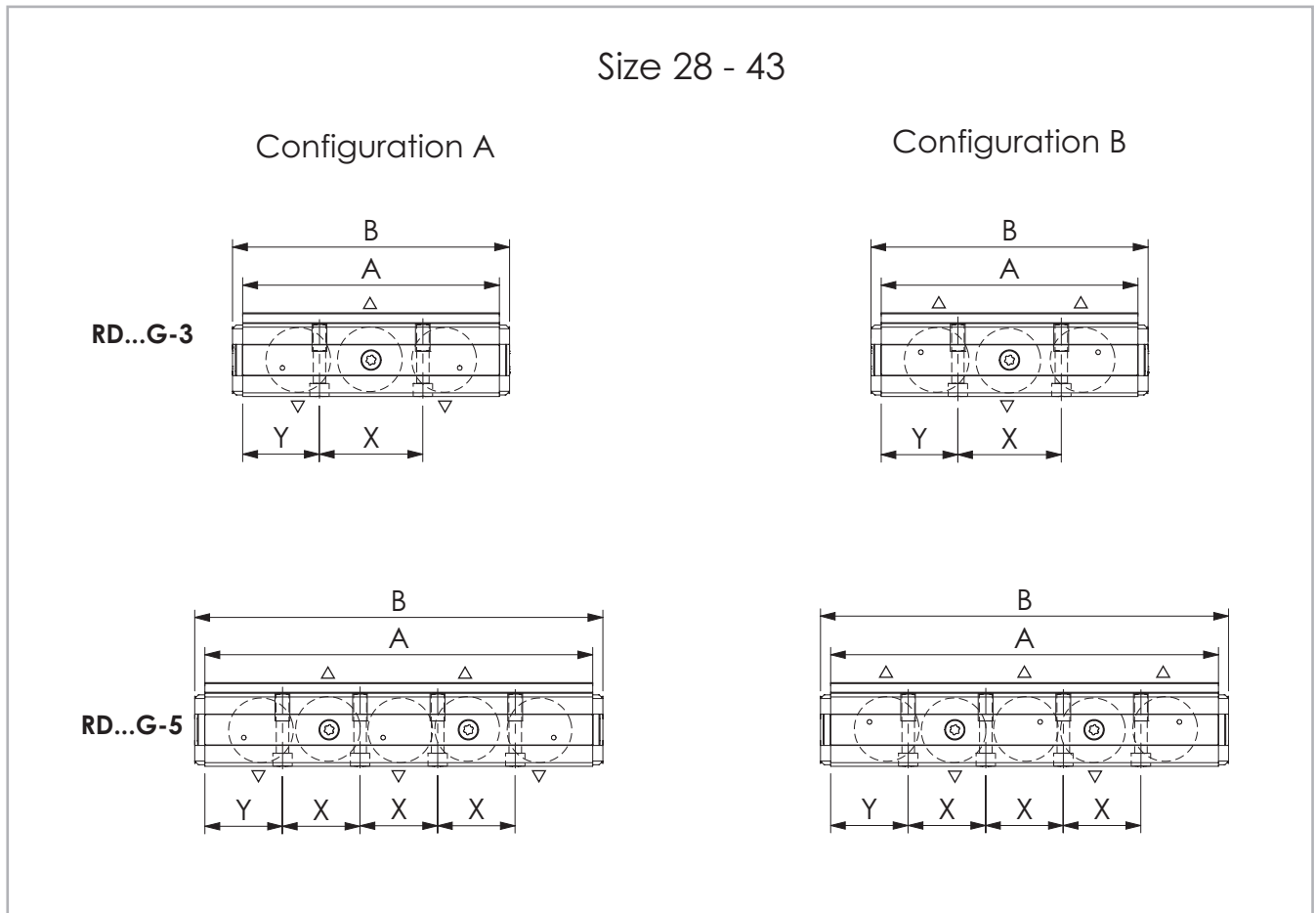

Fig. 24

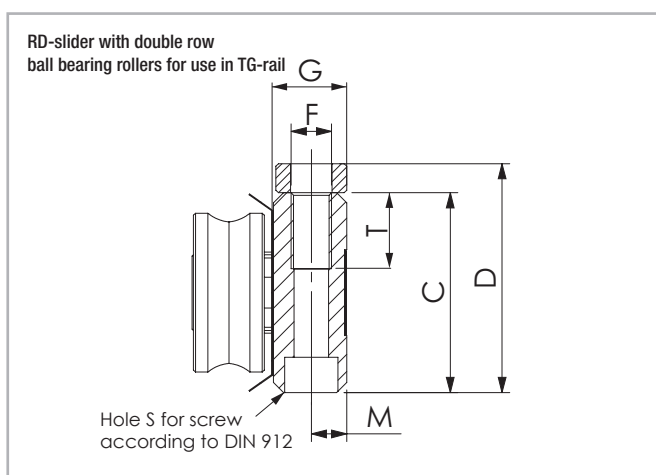

Fig. 25

Type	Size	No. of rollers	A [mm]	B [mm]	C [mm]	D [mm]	T [mm]	M [mm]	S	G [mm]	F	X [mm]	Y [mm]	No. of holes
RDV...G RDA...G RDP...G RDU...G	28	3	97	108	24.9	30.45	15	4.7	M5	9.7	M6	36	30.5	2
		5	142	153								27	30.5	4
	43	3	139	150	39.5	45.25	15	7	M6	14.5	M8	56	41.5	2
		5	210	221								42	42	4

For information about the roller sliders configuration, see pg. CR-22 and CR-23.
 For information about the roller type, see pg. CR-18, tab. 10.

Tab. 7

C
R

> TG / TMG -rail with sliders

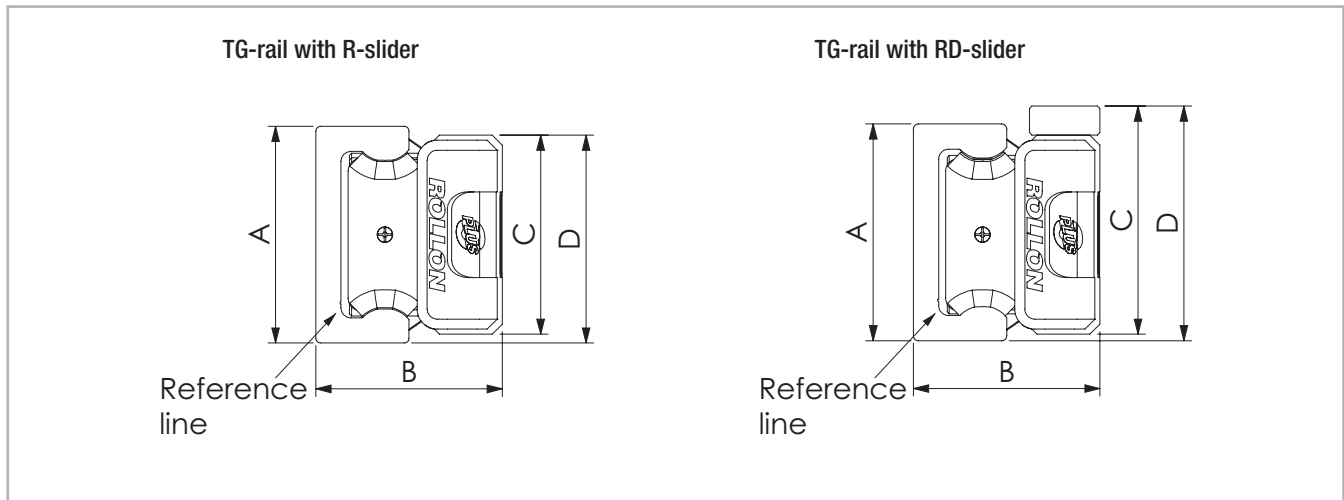

Fig. 26

Configuration	Size	A [mm]		B [mm]		C [mm]		D [mm]	
TMG... / R...G	18	18	+0.2 -0.10	16.5	±0.15	16	0 -0.2	17	+0.2 -0.4
TG... / R...G	28	28	+0.2 -0.10	24	±0.15	24.9	0 -0.2	26.45	+0.2 -0.4
	43	43	+0.3 -0.10	37	±0.15	39.5	0 -0.2	41.25	+0.2 -0.4
TG... / RD...G	28	28	+0.2 -0.10	24	±0.15	24.9	0 -0.2	32	+0.2 -0.4
	43	43	+0.3 -0.10	37	±0.15	39.5	0 -0.2	47	+0.2 -0.4

Tab. 8

> Offset of fixing holes

Principle representation of offset

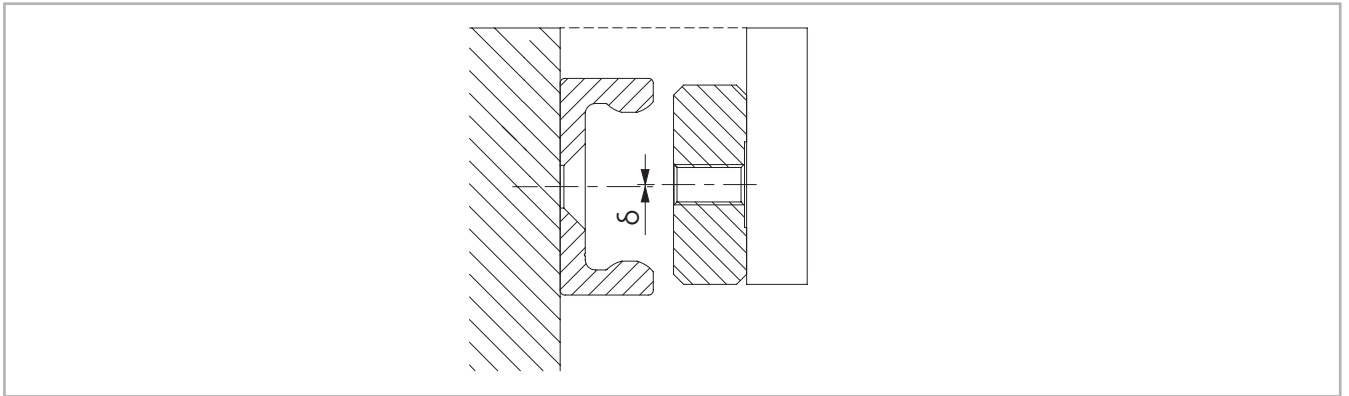

Fig. 27

Configuration	Size	δ nominal [mm]	δ maximum [mm]	δ minimum [mm]
TMG... / R...G	18	0	-0.25	+0.25
TG... / R...G	28			
	43			
TG... / RD...G	28			
	43			

Tab. 9

Accessories 

> Rollers

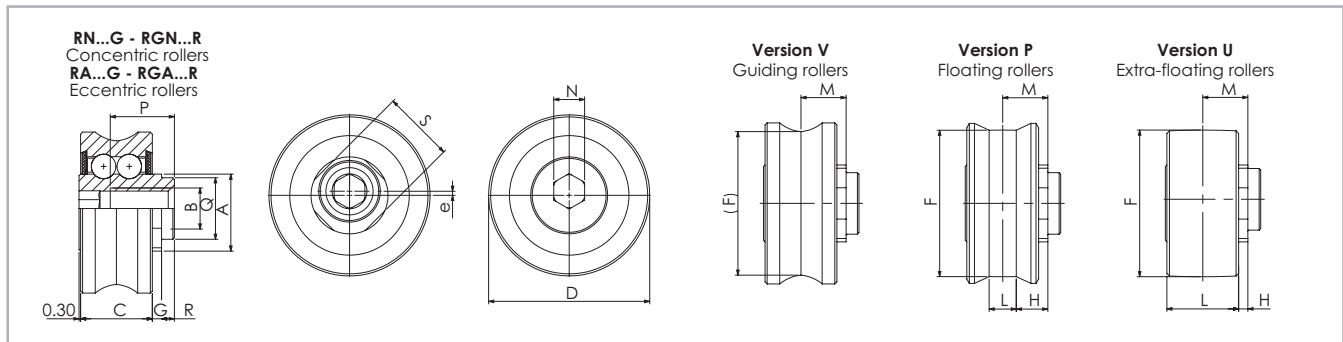

Seals: 2RS splash proof seal.
Note: the rollers are lubricated for life.

Fig. 28

Type		e [mm]	D [mm]	C [mm]	M [mm]	G [mm]	A [mm]	B [mm]	P [mm]	F [mm]	L [mm]	H [mm]	R [mm]	Q [mm]	S	N	C [N]	Co _{rad} [N]	Co _{ax} [N]	Weight [kg]
Steel	Inox																			
RNVG18	-	-	13.2							-	-	-					1650	800	230	0.01
RNPG18	-	-	13.2							11.96	2.5	3.35					1650	800	0	
RNUG18	-	-	11.95							11.95	6	1.6					1150	560	0	
RAVG18	-	-	13.2	7	4.6	1.1	6.8	M4	5.4	-	-	-	-	-	-	3	1650	800	230	
RAPG18	-	0.4	13.2							11.96	2.5	3.35					1650	800	0	
RAUG18	-	-	11.95							11.95	6	1.6					1150	560	0	
RGNV28R	RGNVX28R	-	20.75							-	-	-					3000	1600	460	0.02
RGNP28R	RGNPX28R	-	20.75							18.81	4	4.1					3000	1600	0	
RGNU28R	RGNUX28R	-	18.81							18.81	8	2.1		1.5	8 h7	10	2300	1120	0	
RGAV28R	RGAVX28R	-	20.75	9	6.1	1.6	10.8	M5	8	-	-	-				4	3000	1600	460	
RGAP28R	RGAPX28R	0.6	20.75							11.96	4	4.1					3000	1600	0	
RGAU28R	RG AUX28R	-	18.81							11.95	8	2.1					2300	1120	0	
RGNV43R	RGNVX43R	-	31.4							-	-	-					7600	4000	1190	0.05
RGNP43R	RGNPX43R	-	31.2							28.59	5.3	6.15					7600	4000	0	
RGNU43R	RGNUX43R	-	28.59							28.59	13	2.3		2.5	11 h7	14	5700	2800	0	
RGAV43R	RGAVX43R	-	31.4	14	8.8	1.8	15	M8	12.5	-	-	-				6	7600	4000	1190	
RGAP43R	RGAPX43R	0.8	31.2							28.59	5.3	6.15					7600	4000	0	
RGAU43R	RG AUX43R	-	28.59							28.59	13	2.3					5700	2800	0	

Rollers size 18 are without protruding pin.

Tab. 10

> Wipers

Pair of wipers WR for R- / RD- slider

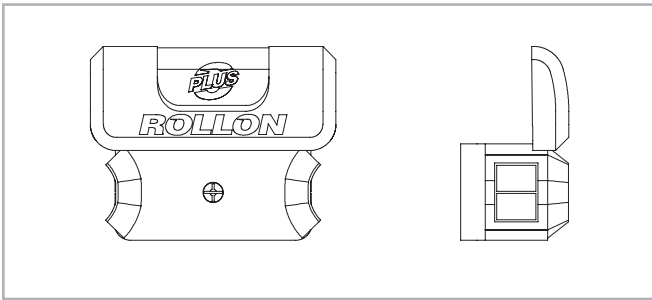

Fig. 29

Rail size	Pair of wipers
18	ZK-WR18G
28	ZK-WR28G
43	ZK-WR43G

Tab. 11

> Alignment fixtures

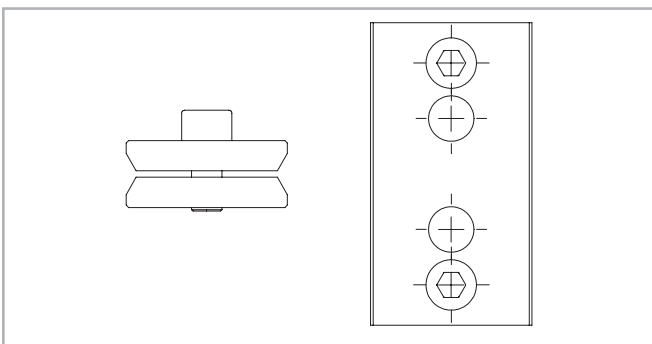

Fig. 30

Rail size	Alignment fixture
18	ATMG18
28	ATG28
43	ATG43

Tab. 12

> Fixing screws

When a rail with counterbored holes is delivered, the Torx® screws are provided in the right quantity.

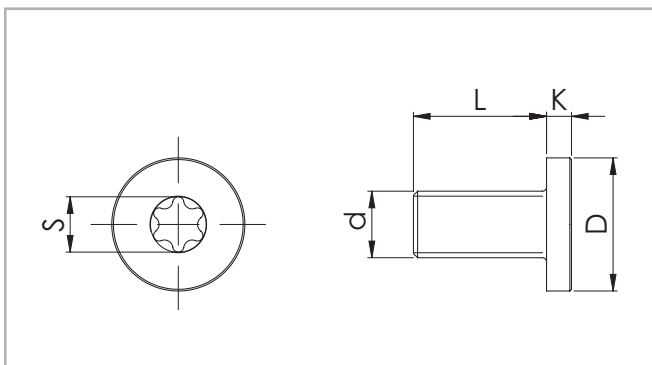

Fig. 31

Rail size	d	D [mm]	L [mm]	K [mm]	S	Tightening torque [Nm]
18	M4 x 0.7	8	8	2	T20	3
28	M5 x 0.8	10	10	2	T25	9
43	M8 x 1.25	16	16	3	T40	22

Tab. 13

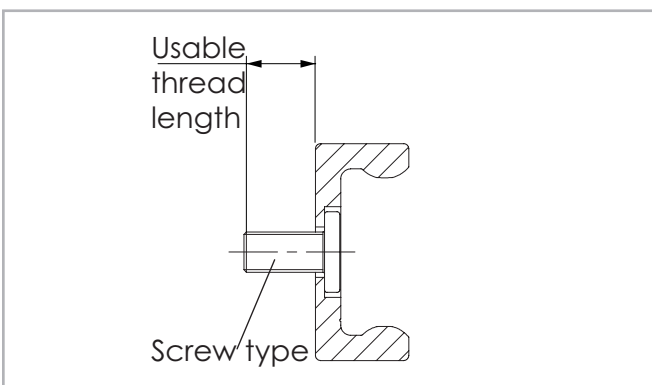

Fig. 32

Rail size	Screw type	Usable thread length [mm]
18	M4 x 8	7.2
28	M5 x 10	9
43	M8 x 16	14.6

Tab. 14

Technical Instructions



> Linear accuracy

Linear accuracy is defined as the maximum deviation of the slider in the rail based on the side and support surface during straight line movement.

The linear accuracy, depicted in the graphs below, applies to rails that are carefully installed with all the provided screws on a level and rigid foundation.

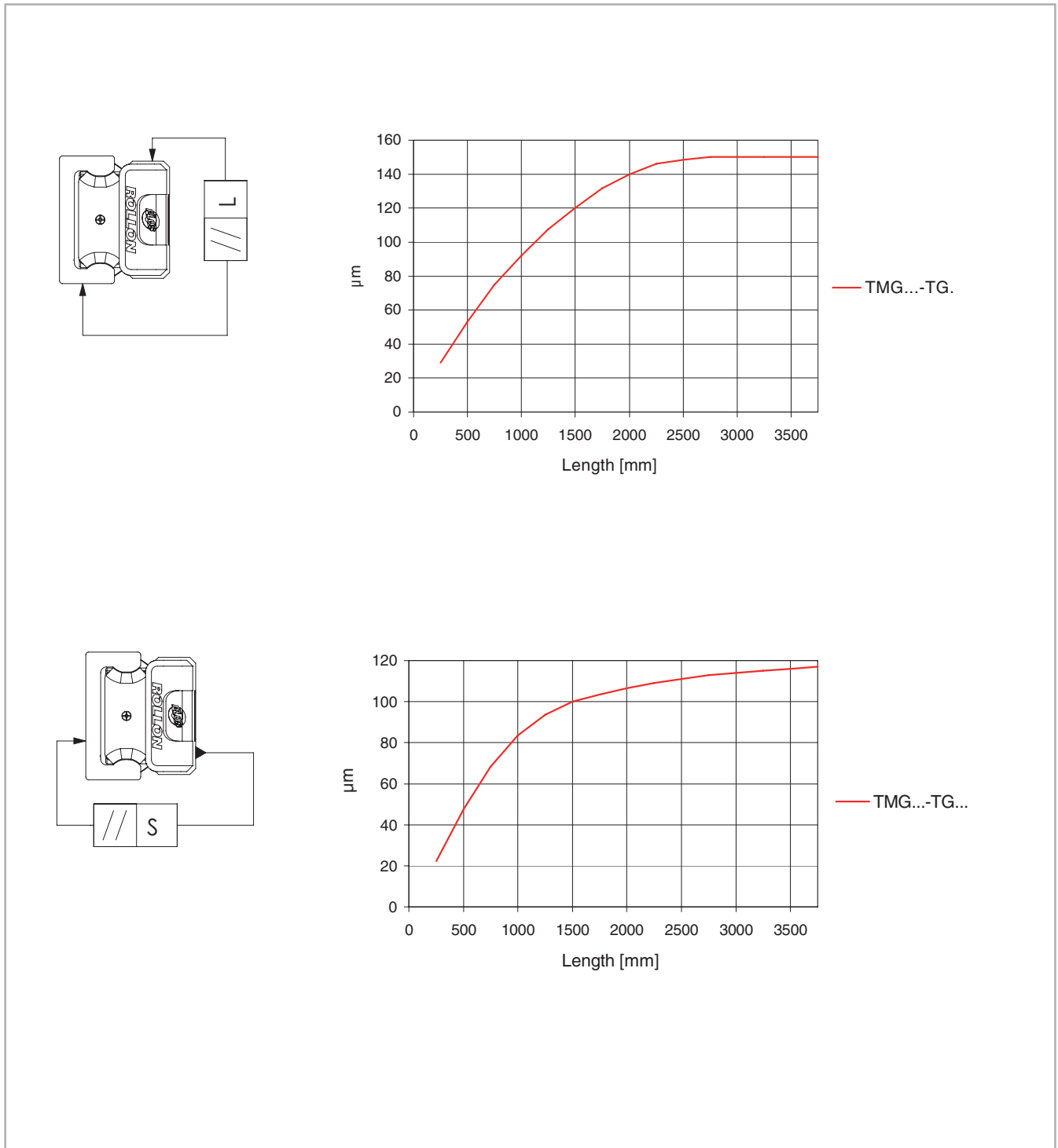
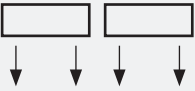
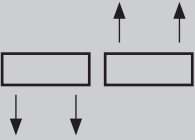

Fig. 33

Deviation of accuracy with two 3 roller sliders in one rail

Type	
ΔL [mm] Slider with equal arrangement 	0.2
ΔL [mm] Slider with opposite arrangement 	1.0
ΔS [mm]	0.05

Tab. 15

> Points of contact between rollers and raceways

Guiding rollers (Version V)

The guiding rollers have two contact points with the raceways. This creates a well constrained movement of rollers on the raceway, in both radial and axial direction.

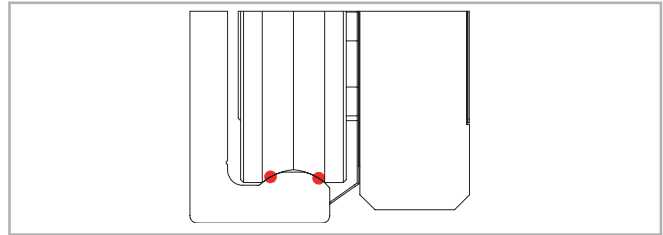

Fig. 34

Floating rollers (Version P)

The floating rollers engage only the peak of the raceway. They are constrained radially but allowed to float in the axial direction between the two shoulders. The rollers can also rotate a little.

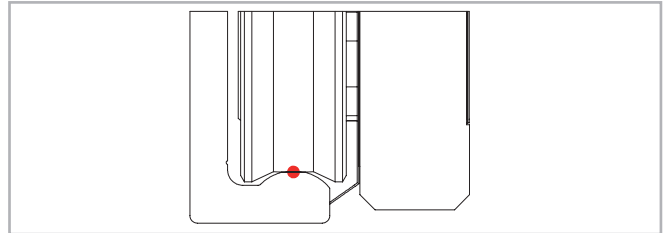

Fig. 35

Extra-floating rollers (Version U)

The extra-floating rollers engage only the peak of the raceway. They are constrained radially but allowed to float in the axial direction without limitation. The completely flat surface of the rollers allows an axial travel wider than the floating rollers, and they can also rotate a little.

(Note: being free from lateral shoulders, extra-floating rollers could run out of the rail or against the bottom rail when exceeding the nominal floating capacity)

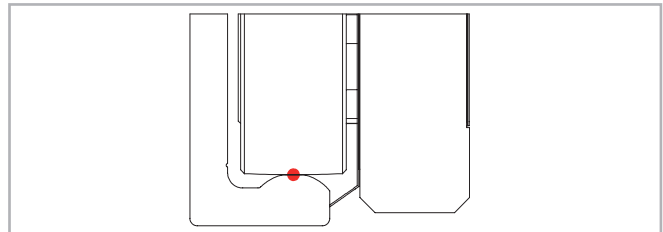

Fig. 36

> Sliders composition

Guiding sliders (RV -slider)

Guiding sliders are built only with guiding rollers. For this reason, they are completely constrained and can support loads and moments in all directions, especially the radial ones.

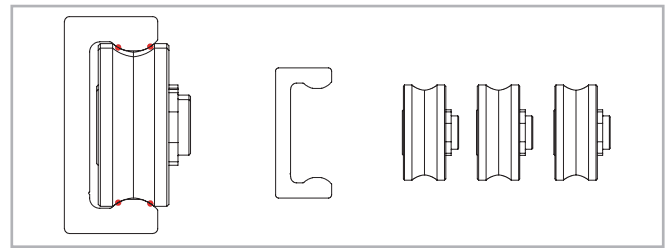

Fig. 37

Floating sliders (RP -slider)

Floating sliders are built only with floating rollers. They are able to slightly travel axially and to rotate a bit without affecting the preload or the smooth running quality.

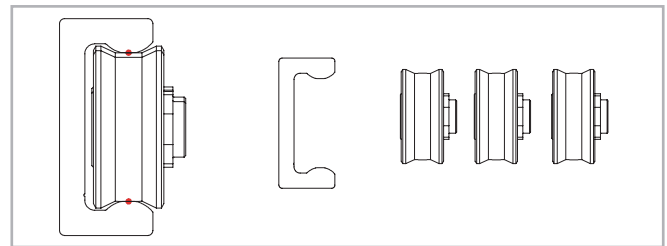

Fig. 38

Extra-floating sliders (RU -slider)

Extra-floating sliders are built only with extra-floating rollers. They are able to fully travel axially and to rotate a bit without affecting the preload or the smooth running quality. (Note: being free from lateral shoulders, extra-floating sliders could run out of the rail or against the bottom rail when exceeding the nominal floating capacity).

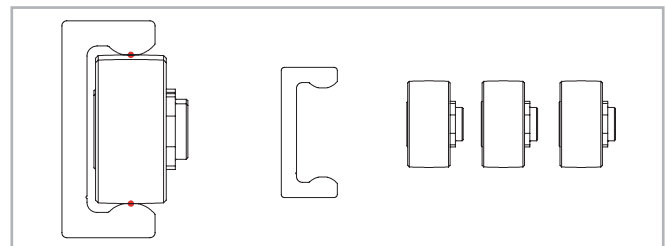

Fig. 39

Rotating sliders (RA -slider)

Rotating sliders are built mixing guiding and floating rollers. They are able to carry full radial load and retain the ability to guide the payload as it travels, while also rotating a bit without affecting the preload or the smooth running quality. Rotating sliders are used to absorb angular errors in the mounting surfaces.

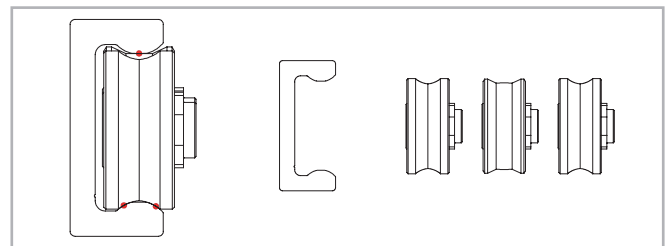

Fig. 40

> V+P/U-system tolerance compensation

Axial deviations in parallelism

This problem occurs fundamentally by insufficient precision in the axial parallelism of the mounting surfaces, which results in an excessive load on the slider and thus causes drastically reduced service life.

The combination of two rails, one featuring a RV-slider and one featuring a RP-slider or RU-slider, creates a system that allows to compensate large axial misalignment errors. The limit is set by the axial misalignment permitted by the RP- or RU-slider.

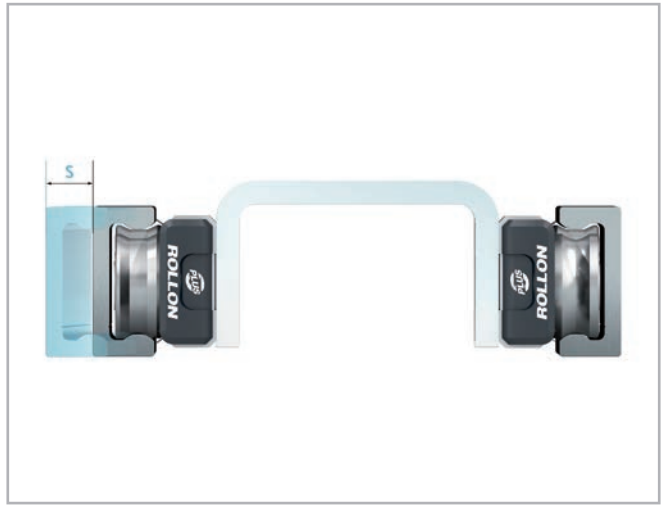

Fig. 41

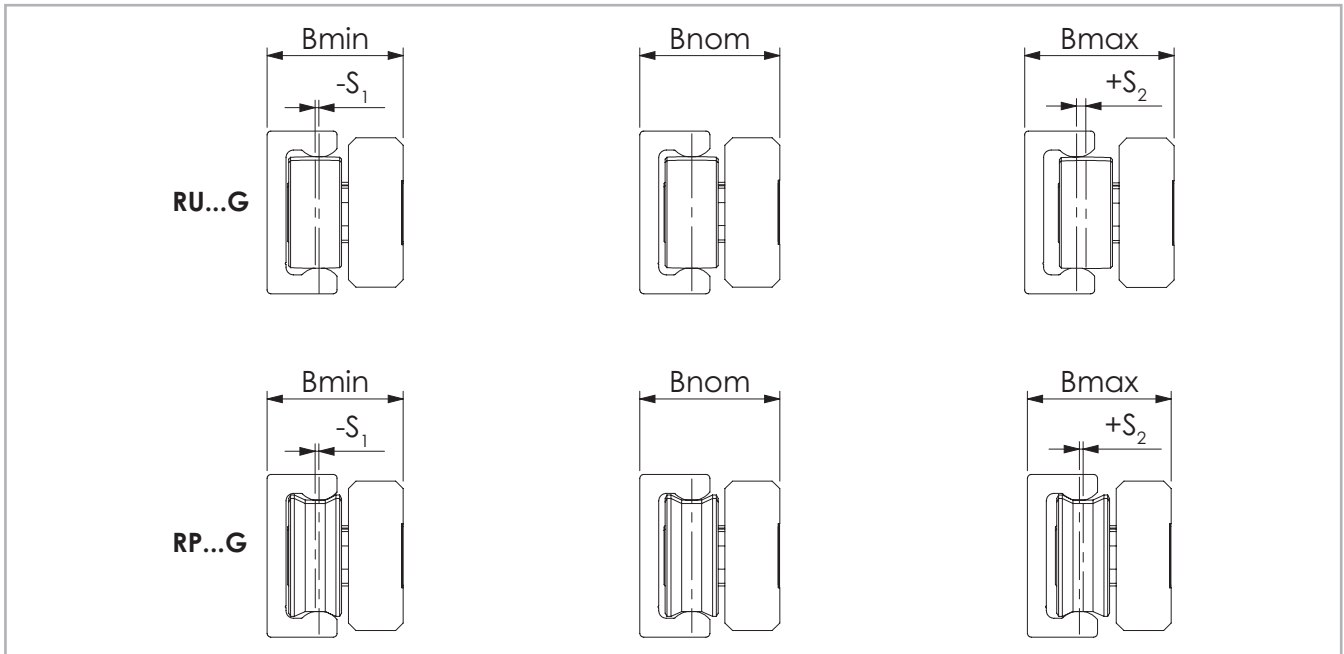

Fig. 16

Maximum offset

RP-sliders feature floating rollers that are able to slightly travel axially between the two shoulders, while RU-sliders feature extra-floating rollers that are able to fully travel axially without constraints. The maximum axial offset that can be compensated is made up of the combined values S_1 and S_2 listed in table 16. Considered from a nominal value B_{nom} as the starting point, S_1 indicates the maximum offset into the rail, while S_2 represents the maximum offset towards the outside of the rail.

Slider type	S_1 [mm]	S_2 [mm]	B_{min} [mm]	B_{nom} [mm]	B_{max} [mm]
RPG18	0.4	0.4	16.1	16.5	16.9
RP28G RDP28G	0.4	0.4	23.6	24	24.4
RP43G RDP43G	1	1	36	37	38
RUG18	0.4	1	16.1	16.5	17.5
RU28G RDU28G	0.4	2	23.6	24	26
RU43G RDU43G	1	2.5	36	37	39.5

Tab. 16

The application example in the adjacent drawing (see fig. 44) shows that the V+P/U-system implements a problem-free function of the slider even with an angled offset in the mounting surfaces.

If the length of the guide rails is known, the maximum allowable angle deviation of the screwed surfaces can be determined using this formula (the floating slider moves here from the innermost position S_1 to outermost position S_2):

$\alpha = \arctan \frac{S^*}{L}$	$S^* = \text{Sum of } S_1 \text{ and } S_2$ $L = \text{Length of rail}$
----------------------------------	--

Fig. 43

The following table (tab. 17) contains guidelines for this maximum angle deviation α , achievable with the longest guide rail from one piece.

Size	Rail length [mm]	Offset S [mm]	Angle α [°]
RPG18	2960	0.8	0.015
RP28G	3600	0.8	0.012
RP43G	3600	2	0.031
RUG18	2000	1.4	0.040
RU28G	3600	2.4	0.038
RU43G	3600	3.5	0.055

Tab. 17

The V+P/U-system can be designed in different arrangements (see fig. 45). A TG-rail with RV-slider accepts the vertical components of load A TG-rail with RP-slider or RU-slider slider attached underneath the component to be guided prevents the vertical panel from swinging and is used as moment support. In addition, a vertical offset in the structure, as well as possible existing unevenness of the support surface, is compensated.

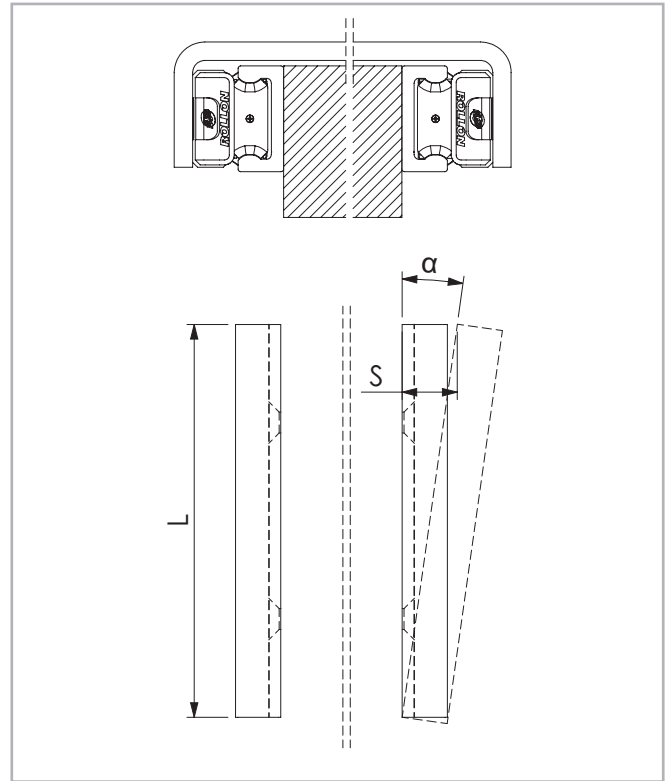

Fig. 44



Fig. 45

> A+P/U-system tolerance compensation

Deviations in parallelism in two planes

The A+P/U-system, like the V+P/U, can compensate for axial deviations in parallelism. The RP- or RU-slider allows to correct the longitudinal parallelism error and, additionally, the RA-slider can rotate in the rail, to compensate for other deviations in parallelism, e.g. height offset.

RA-sliders are built mixing guiding and floating rollers. They carry the full radial load and retain the ability to guide the payload as it travels, while being able to rotate in the rail without affecting the preload or the smooth running quality. The combination of two rails, one featuring a RA-slider and one featuring a RP- or RU-slider, can be used to absorb both axial and angular errors in the mounting surfaces.

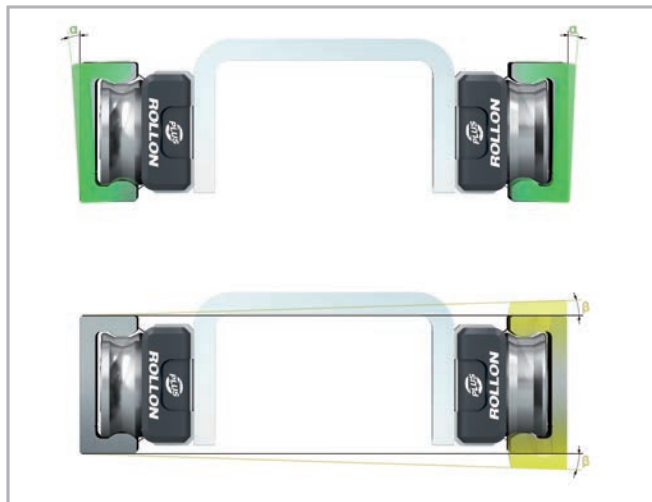

Fig. 46

The maximum allowable rotation angle of the RA-sliders are shown in the following table 18 and figure 47. α_1 is the maximum rotation angle counterclockwise, α_2 is clockwise.

Slider type	α_1 [°]	α_2 [°]
RAG18	1	1
RA28G RDA28G	0.85	0.85
RA43G RDA43G	1.3	1.3

Tab. 18

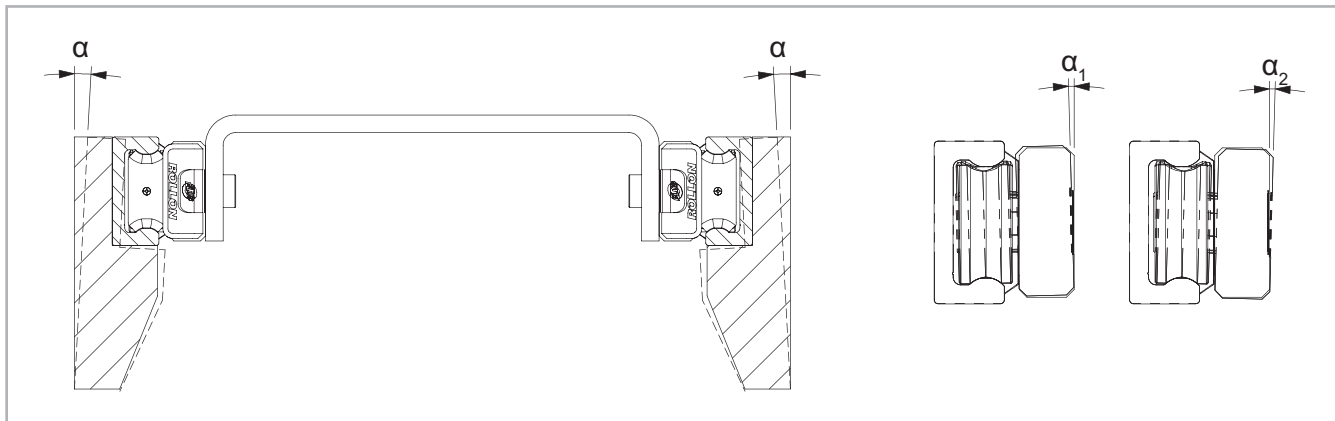

Fig. 47

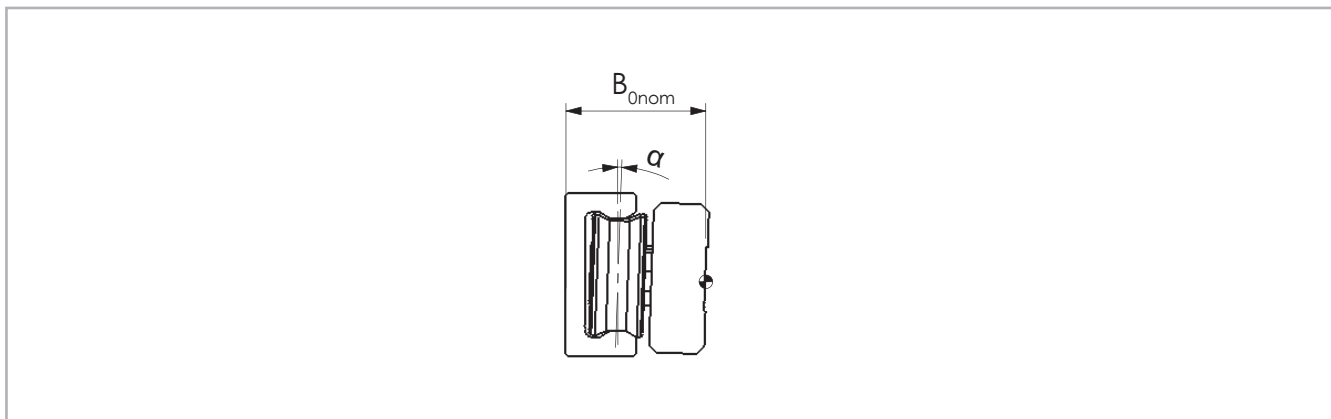

Fig. 48

Maximum offset

It must be noted that the RP- or RU-slider in one rail will turn during the movement and rotation of the RA-slider in the other to allow an axial offset. During the combined effect of these movements, you must not exceed the maximum values (see tab. 19). B_{0nom} is a recommended nominal starting value for the position of a RP- or RU-slider when part of a tolerance compensation system.

Slider type	B_{0nom} [mm]	Angle α [°]
RPG18	16.5	1°
RP28G RDP28G	24	1.7°
RP43G RDP43G	37	2.6°
RUG18	16.5	1°
RU28G RDU28G	24	1.7°
RU43G RDU43G	37	2.6°

Tab. 19

If a RA-slider is used in combination with a RP- or RU-slider with guaranteed problem-free running and without extreme slider load, a pronounced height difference between the two rails can also be compensated. The following illustration shows the maximum height offset b of the mounting surfaces in relation to the distance a of the rails (see fig. 49).

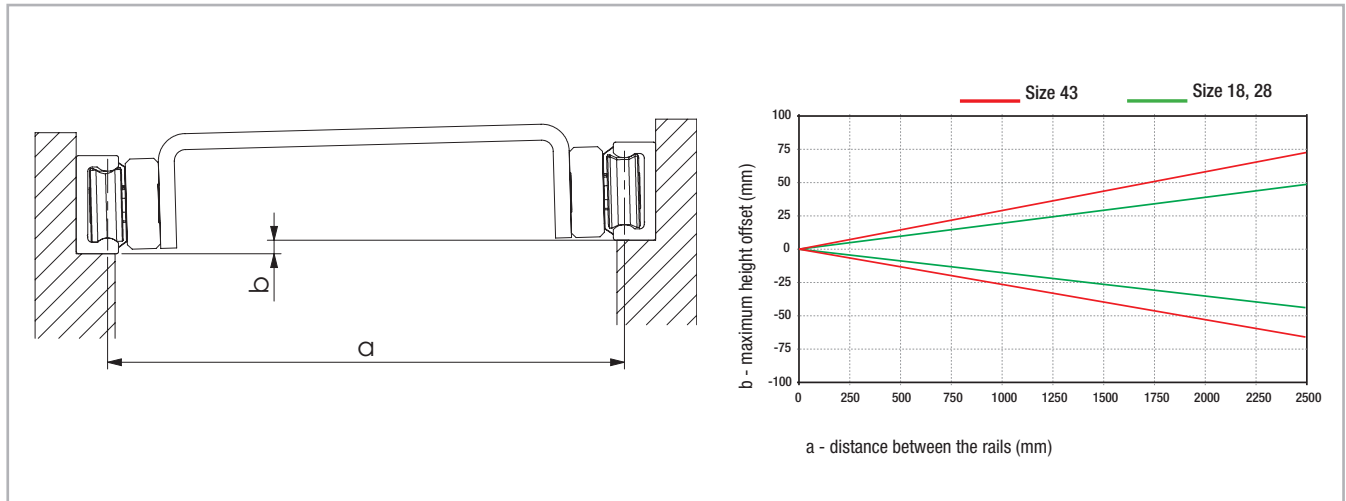

Fig. 49

Even the A+P/U-system can be used in different arrangements. If the same example as with the V+P/U-system is observed (see pg. CR-25, fig. 45), this solution, in addition to the prevention of vibrations and moments, also enables the compensation of larger deviations in parallelism in the vertical direction, without negative consequences to the guide. This is particularly important for longer strokes as it is more difficult to obtain a correct vertical parallelism.



Fig. 50

> Preload

Preload classes

The factory installed systems, consisting of rails and sliders, are available in two preload classes:

Standard preload K1 means a rail-slider combination with minimum preload which means the rollers are adjusted free of clearance for optimal running properties.

Usually preload K2 is used for rail-slider systems for increasing the rigidity. When using a system with K2 preload a reduction of the loading capacities and service life must be taken into consideration (see tab. 20).

Preload class	Reduction y
K1	-
K2	0.1

Tab. 20

This coefficient y is used in the calculation formula for checking the static load and lifetime (see pg. CR-95, fig. 172 and pg. CR 99, fig. 189).

The interference is the difference between the contact lines of the rollers and the raceways of the rail.

Preload class	Interference* [mm]	Rail size
K1	0.01	all
K2	0.03	18
	0.04	28
	0.06	43

* Measured on the largest interior dimension between the raceways Tab. 21

> Drive force

Frictional resistance

The drive force required for moving the slider is determined by the combined resistance of the rollers, wipers and seals.

The ground raceways and rollers have a minimal coefficient of friction, which remains almost the same in both the static and dynamic state. The wiper and longitudinal seals are designed for an optimum protection of the system, without a significant negative influence on the quality of motion. The overall friction of the Compact Rail also depends on external factors such as lubrication, preload and additional forces. Table 22 below contains the coefficients of friction for each slider type.

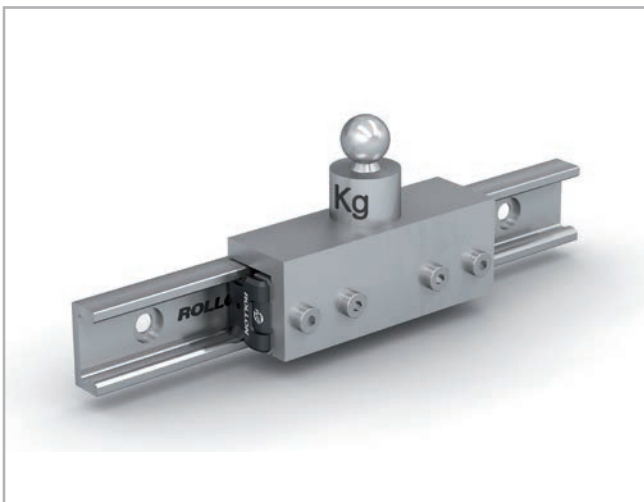

Fig. 51

Size	μ Roller friction	μ_w Wiper friction	μ_s Friction of longitudinal seals
18	0.003	$\frac{\ln(m \cdot 1000)^*}{0.98 \cdot m \cdot 1000}$	0.0015
28	0.003	$\frac{\ln(m \cdot 1000)^*}{0.06 \cdot m \cdot 1000}$	$\frac{\ln(m \cdot 1000)^*}{0.15 \cdot m \cdot 1000}$
43	0.005		

* Kilograms must be used for load m

Tab. 22

The values given in Table 22 apply to external loads, which, with sliders with three rollers, are at least 10 % of the maximum load rating. For calculating the driving force for lower loads, please contact Rollon technical support.

Calculation of drive force

The minimum required drive force for the slider is determined with the coefficients of friction (see tab. 22) and the following formula (see fig. 52):

$F = (\mu + \mu_w + \mu_s) \cdot m \cdot g$	<p>m = mass (kg) g = 9.81 m/s²</p>
---	---

Fig. 52

Example calculation:

If a R...43G slider is used with a radial load of 100 kg, the result is $\mu = 0.005$; from the formula the following is calculated:

$$\mu_s = \frac{\ln(100000)}{0.15 \cdot 100000} = 0.00076$$

$$\mu_w = \frac{\ln(100000)}{0.06 \cdot 100000} = 0.0019$$

Fig. 53

This is the minimum drive force for this example:

$$F = (0.005 + 0.0019 + 0.00076) \cdot 100 \cdot 9.81 = 7.51 \text{ N}$$

Fig. 54

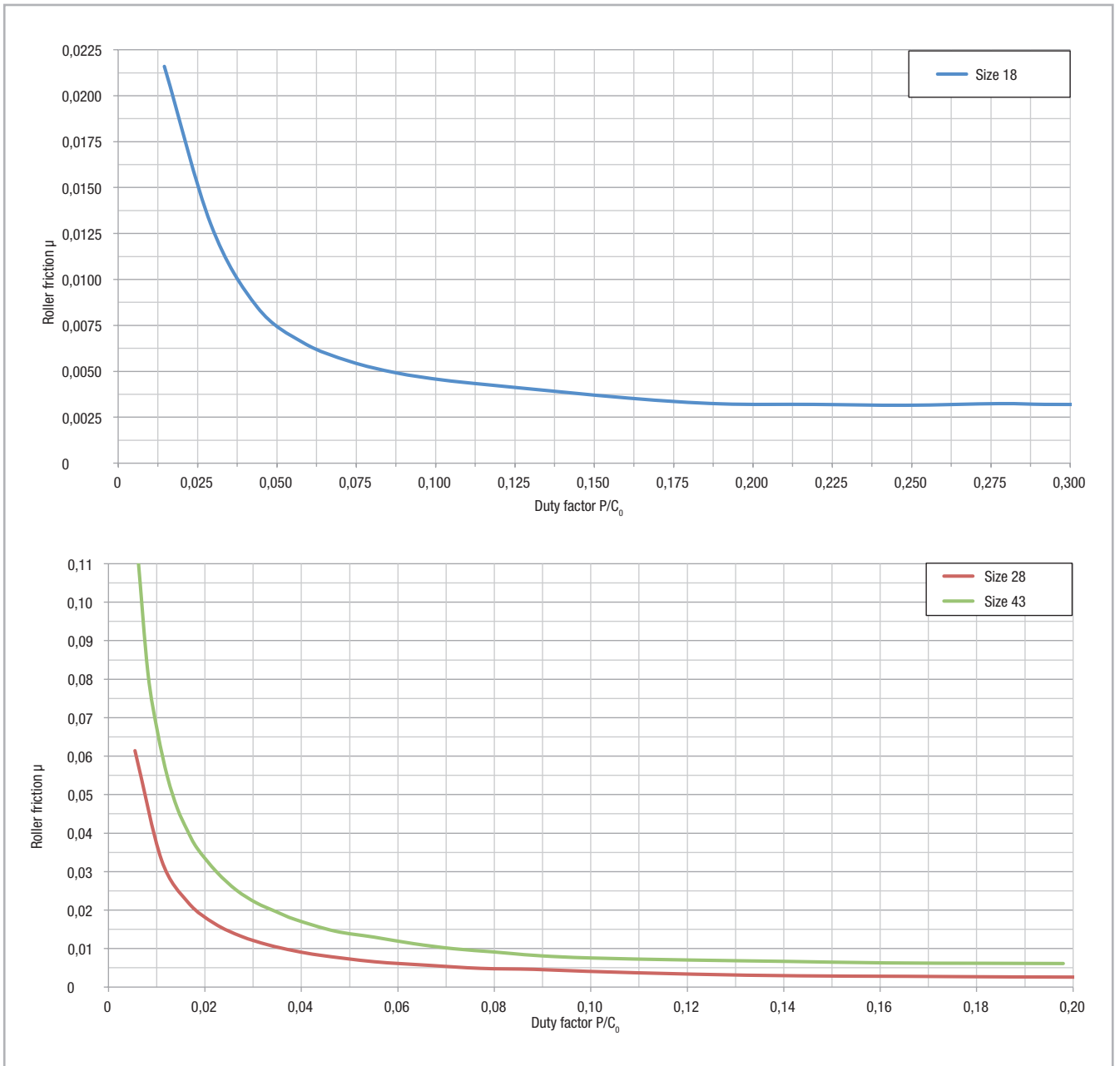

Fig. 55

> Lubrication

Roller pin lubrication

The bearings inside the rollers are lubricated for life. To reach the calculated service life (see pg. CR-107), a film of lubricant should always be

present between the raceway and roller, this also serves to protect against corrosion of the ground raceways.

Lubrication of the raceways

Proper lubrication during normal conditions:

- reduces friction
- reduces wear
- reduces the load of the contact surfaces through elastic deformations
- reduces running noise

> Slider lubrication

The sliders are equipped with wiper heads that include lubricated felts which slowly release oil on the raceways for a long time. The wiper heads can be recharged from the front through a dedicated access hole by means of an oiling syringe.

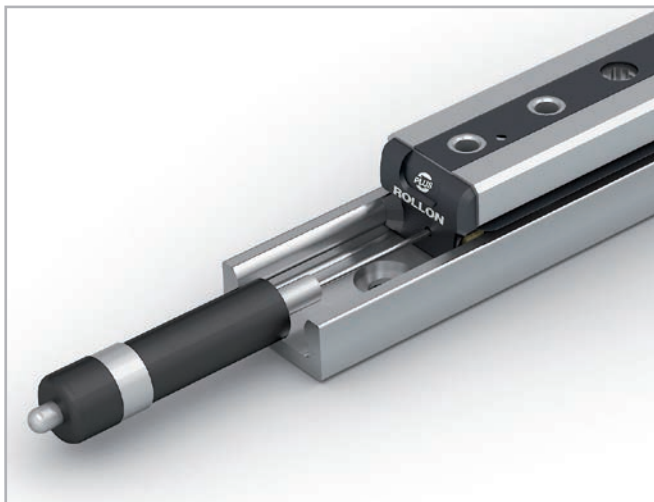

Fig. 56

The durability of the lubrication delivered by the wiper heads depends on the conditions of use. In the normal clean indoor applications, it is suggested to refill the oil every 0.5 million of cycles, 1000 km or 1 year of use whichever comes first. In different conditions, it could be necessary to refill more often, depending on the level of environment criticality. In case of severe dust and dirt conditions, it is suggested to change the entire wiper head with a new one.

When refilling the oil or the substituting the wiper heads, it is recommended to clean the raceways of the guide.

Lubricant	Thickening agent	Temperature range [°C]	Kinematic viscosity 40°C [mm ² /s]
Mineral oil	Lithium soap	-20... to +120	approx 110

Tab. 23

> Corrosion protection

All rails and slider bodies have a standard corrosion protection system by means of electrolytic-zinc plating according to ISO 2081, except for size 18 rails where the standard treatment is Rollon-Nox hardening. If increased corrosion protection is required, application-specific surface treatments are available upon request for rails and slider bodies sizes 28

and 43, e.g. approved nickel plated for use in the food industry. In this case, the chosen treatment must be specified in the order for both rails and sliders using the appropriate code shown in the table below. For more information contact Rollon technical support.

Treatment	Characteristics
Rollon-Nox	Patented high depth nitride hardening and black oxidation treatment that provides good durability under high loads or frequencies and good corrosion resistance. It is standard for rails size 18 and it's not available for other sizes.
Zinc Plating ISO 2081	Standard treatment for rails sizes 28-43 and all slider bodies, it is ideal for indoor applications. When applied to the rail, it is removed from the raceways by the subsequent grinding process. Zinc-plated sliders are supplied with steel rollers. Not available for size 18.
ZincNickel ISO19598 (Z)	Ideal for outdoor applications. Sliders ordered with Rollon Alloy treatment are supplied with stainless steel rollers to further increase the corrosion resistance. Not available for size 18.
Rollon E-coating (K)	As zinc-plated version with additional electro painting that provides a fine black finishing to the entire rail. When applied to the rail, the slider can partially remove the coating from the raceways on the running contact point after a period of use. Sliders ordered with Rollon E-Coating are supplied with stainless steel rollers to further increase the corrosion resistance.
Nickel Plating (N)	Provides high resistance to chemical corrosion and is ideal for applications in medical or food related environments. When applied to the rail, raceways are coated too. Sliders ordered with Nickel Plating treatment are supplied with stainless steel rollers to further increase the corrosion resistance. Not available for size 18.

Tab. 24

> Speed and acceleration

The Compact Rail product family is suitable for high operating speeds and accelerations.

Size	Speed [m/s]	Acceleration [m/s ²]
18	3	10
28	5	15
43	7	15

Tab. 25

> Operating temperatures

The temperature range for continuous operation is: -20 °C / +120 °C with occasional peaks up to +150 °C.

Installation instructions

> Fixing holes

V-holes with 90° bevels

The selection of rails with 90° countersunk holes is based on the precise alignment of the threaded holes for installation. Here the complex alignment of the rail to an external reference is omitted, since the rail aligns during installation by the self-centering of the countersunk screws on the existing hole pattern.

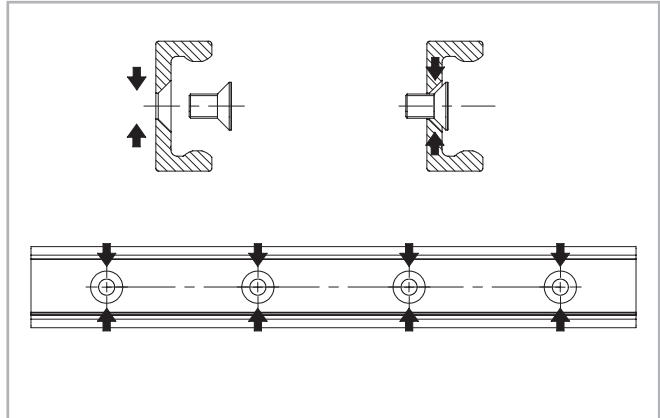

Fig. 57

C-holes with cylindrical counterbore

When a rail with counterbored holes is delivered, the Torx® screws are provided in the right quantity. The cylindrical screw has, as shown, some play in the countersunk fixing hole, so that an optimum alignment of the rail can be achieved during installation (see fig. 58).

The area T is the diameter of the possible offset, in which the screw center point can move during the precise alignment.

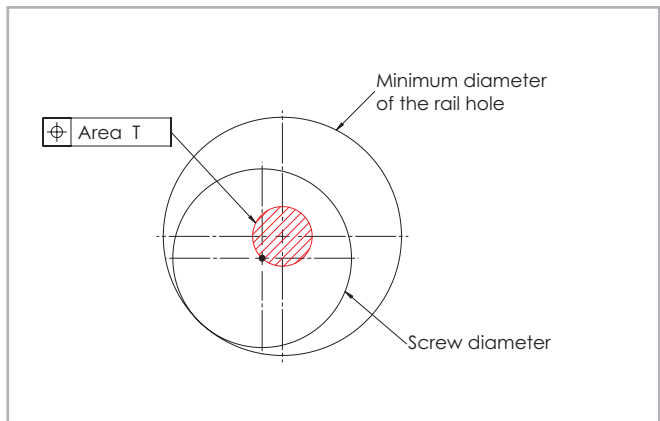

Fig. 58

Rail type	Area T [mm]
TMGC18	Ø 1.0
TGC28	Ø 1.0
TGC43	Ø 2.0

Tab. 26

Chamfers

Chamfers must be realized for both C-holes and V-holes rails. The minimum chamfers on the fixing threads are listed on the table below.

Size	Chamfer C-holes [mm]	Chamfer V-holes [mm]
18	0.5 x 45°	0.5 x 45°
28	0.6 x 45°	1 x 45°
43	1 x 45°	1 x 45°

Tab. 27

Example for fixing with Torx® screws (custom design)

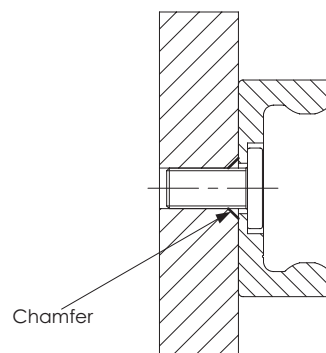

Example for fixing with countersunk screws

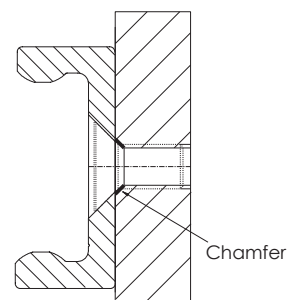

Fig. 59

> Adjusting the sliders

If requested in the order, rails and sliders are delivered as a system with factory adjustment. If rails and sliders are supplied separately or if the slider is to be mounted in another rail, the bearings will need to be adjusted. For sections 28 and 43, the preload can be calibrated using one of the following procedures. For section 18, the only suitable approach is to use the hexagonal spanner.

Common preliminary operations:

- (1) Check that the raceways are clean and remove the wipers, to increase sensitivity for proper preload.
- (2) Place the slider in the rail. It may be necessary to align the bearings to be adjusted with those fixed, to facilitate insertion. Excessive offset may make insertion difficult. Use a flat or hexagonal spanner.
- (3) Use a medium threadlocking adhesive in the screws.
- (4) Lightly tighten the upper bearing screw without over-tightening. Vice versa if the screw has already been previously tightened, loosen the bearing fixing screws slightly. The bearing must be able to rotate but should not be completely free. Only adjust the eccentric bearings (without the center marked).

With flat spanner

- (5) Position the slider at one end of the rail to simplify insertion of the flat spanner.
- (6) Insert the flat spanner supplied to the side, between the rail and the slider. Take care to insert it from the end of the slider, sliding it under the side seal until it reaches the bearing (Fig. 60). Use the flat spanner to engage the hexagon of the eccentric bearing.
- (7) Turn the flat adjustment spanner clockwise so that the eccentric bearing contacts the raceway opposite the factory-set fixed bearings, thus reducing the slider clearance to zero. Avoid applying a high preload, which would cause high wear and reduce service life.
- (8) While holding the rolling pin in the correct position with the flat adjustment spanner, tighten the fixing screw to ensure that the pin is first locked in position.
- (9) Run the slider and check the preload over the entire length of the rail. The movement must be smooth. If any oscillation/clearance or excessive force is observed, repeat the adjustment operation. Preload is optimized when the slider runs smoothly and without play.
- (10) For sliders with more than 3 bearings, repeat this procedure for each one to be adjusted. Ensure that all bearings have uniform contact with the raceways.
- (11) While maintaining the angular position of the pin with the flat spanner, tighten the adjusted bearing fixing screw with a torque spanner. The prescribed tightening torque is shown in table 28.
- (12) Reinstall the wipers.

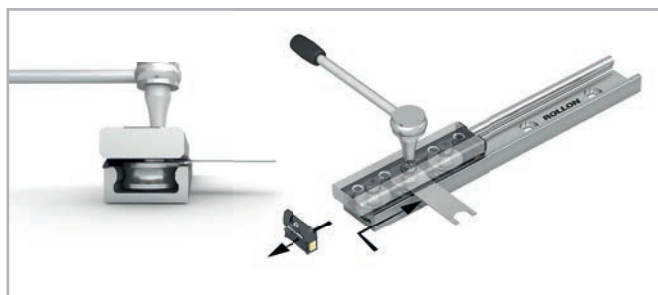

Fig. 60

Slider type	Tightening torque [Nm]
R...18G	3
R...28G	9
R...43G	22

Tab. 28

With hexagonal spanner

- (5) Lock the rail on a stable support so that your hands are free.
- (6) Insert the hexagonal spanner into the pin, passing it through a hole in the track. Turn the hexagonal key slightly so that the eccentric bearing contacts the raceway opposite the factory-set fixed bearings, thus reducing the slider clearance to zero. When turning, support the upper screw by turning in the same direction with the second hexagonal spanner to prevent loosening or changes in preload settings.
- (7) While firmly holding the hexagonal spanner inserted in the off-center pin with one hand, use the other hexagonal spanner to turn and tighten the upper sealing screw of the bearing. Do not lock or unlock the off-center bearing by rotating the pin. Always turn the top screw to lock or loosen the bearing.
- (8) Slide the slider and check the preload over the entire length of the rail. The movement must be smooth. If any oscillation/clearance or excessive force is observed, repeat the adjustment operation. Preload is optimized when the slider runs smoothly and without play.
- (9) Preload values can be checked by slowly inserting the slider at the end of the rail. The insertion force is proportional to the preload. Normally a good setting corresponds to the following min/max forces shown in table 29.
- (10) For sliders with more than 3 bearings, repeat this procedure for each one to be adjusted. Ensure that all bearings have uniform contact with the raceways.
- (11) Tighten the rolling pin/screw definitively precisely using a torque spanner to ensure the correct tightening torque, in accordance with the values in table 28, while holding the hexagonal spanner to the pin, to avoid variations in the preload parameters. Always turn the top screw to lock or loosen the bearing.
- (12) Reinstall the wipers.

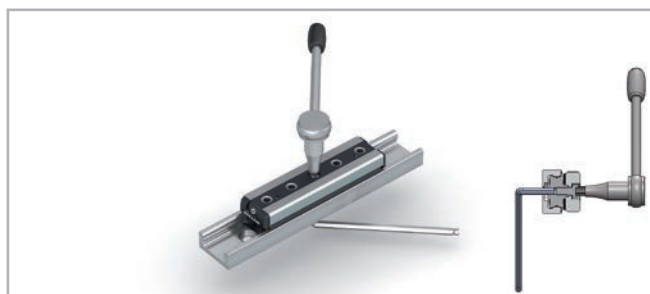

Fig. 61

Slider type	Inserting force	
	F _{min} [N]	F _{max} [N]
R...G18	0,5	2
R...28G	1	5
R...43G	2	10

Tab. 29

> Use of radial ball bearing rollers

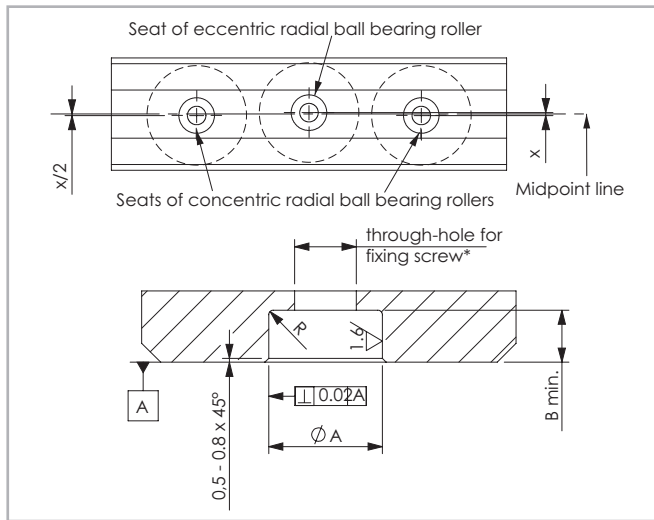

Fig. 62

Slider size	X [mm]	ϕA [mm]	B min. [mm]	Radius R [mm]
18	0.30	-	-	-
28	0.44	$8 + 0.05/+0.02$	2	0.5
43	0.90	$11 + 0.05/+0.02$	3	0.5

Tab. 30

If purchasing "Radial ball bearing rollers" to install on your own structure (see p. CR-18) we advise:

- Using a maximum of 2 concentric radial ball bearing rollers
- Offset the seats of the concentric radial ball bearing rollers with respect to those of the eccentric radial ball bearing rollers according to the table 30.

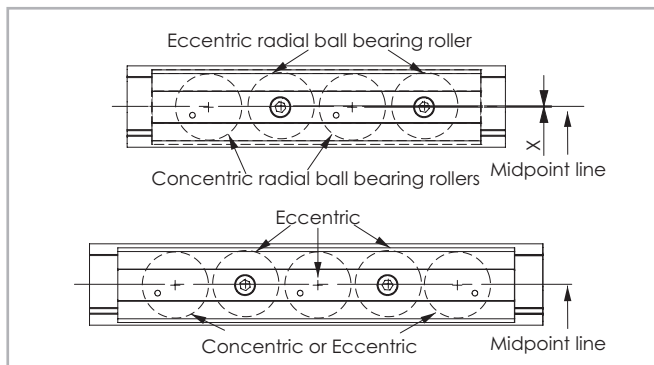

Fig. 63

> Installing the single rail

The rails can be installed in two positions relative to the external force. For axial loading of the slider (fig. 64 pos. 2), the load capacity is reduced because of the decline in contact area caused by the change in position. Therefore, the rails should be installed in such a way that the load on the rollers acts in the radial direction (fig. 64, pos. 1). The number of fixing holes in the rail in combination with screws of property class 10.9 is dimensioned in accordance with the load capacity values. For critical applications with vibrations or higher demand for rigidity, a support of the rail (fig. 64, pos. 3) is advantageous.

This reduces deformation of the sides and the load on the screws. The installation of a rail with counterbored holes requires an external reference for alignment. This reference can also be used simultaneously as rail support if required. All information in this section on alignment of the rails, refers to rails with counterbored holes. Rails with countersunk holes self-align using the specified fixing hole pattern (see pg. CR-34, fig. 57).

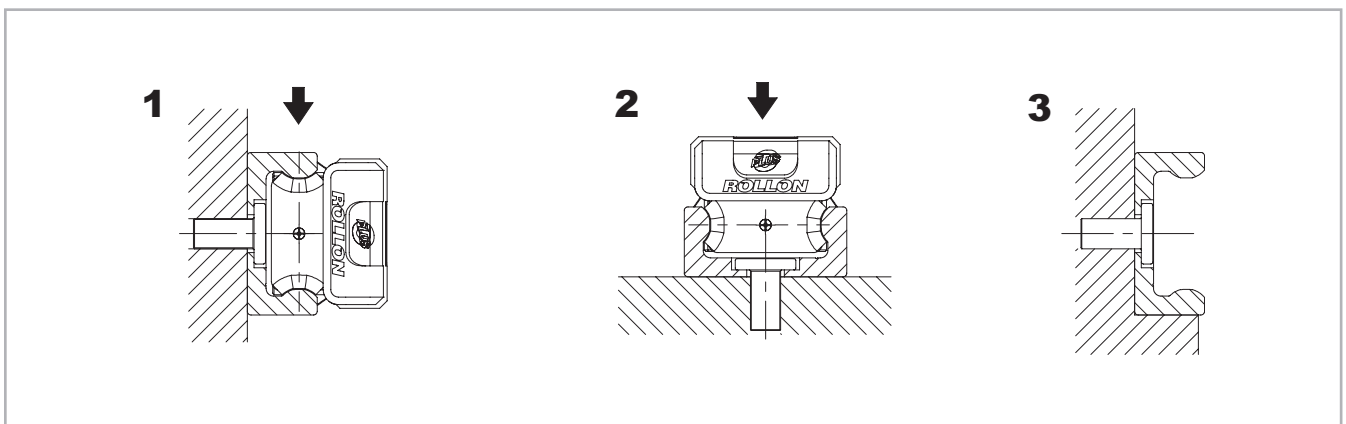

Fig. 64

Rail installation with reference surface as support

- (1) Remove unevenness, burrs and dirt from the support surface.
- (2) Press the rail against the support surface and insert all screws without tightening them.
- (3) Start tightening the fixing screws to the specified torque on one end of the rail while continuing to hold pressure on the rail against the support surface.

Screw type	Torx® tightening torque [Nm]	Countersunk tightening torque [Nm]
M4 (TMG...18)	3	3
M5 (TG...28)	9	6
M8 (TG...43)	22	25

Tab. 31

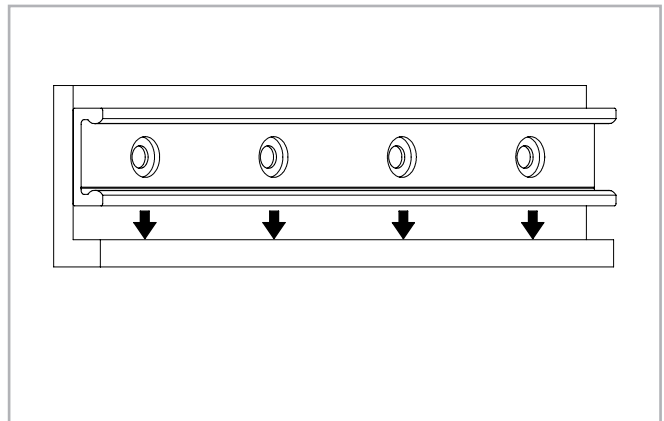

Fig. 65

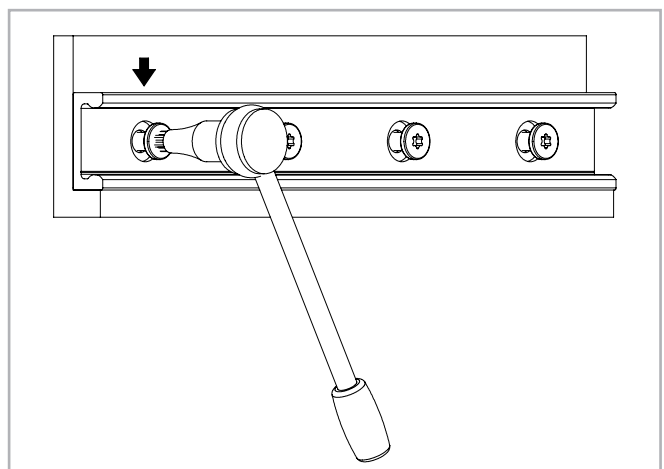

Fig. 66

Rail installation without support

(1) Carefully lay the guide rail with installed slider on the mounting surface and slightly tighten the fixing screws so that the guide rail lightly touches the mounting surface.

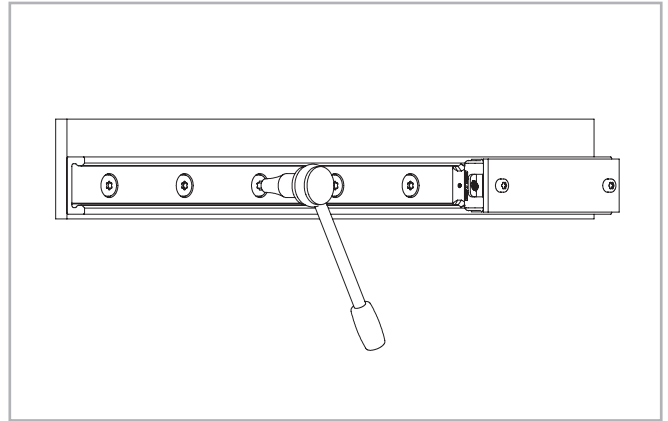

Fig. 67

(2) Install a dial indicator so that the offset of the rail to a reference line can be measured. Now position the slider in the center of the rail and set the dial indicator to zero. Move the slider back and forth between each two hole spacings and carefully align the rail. Fasten the three center screws of this area now with the specified tightening torque, see fig. 68.

(3) Now position the slider on one end of the rail and carefully align the rail to zero on the dial indicator.

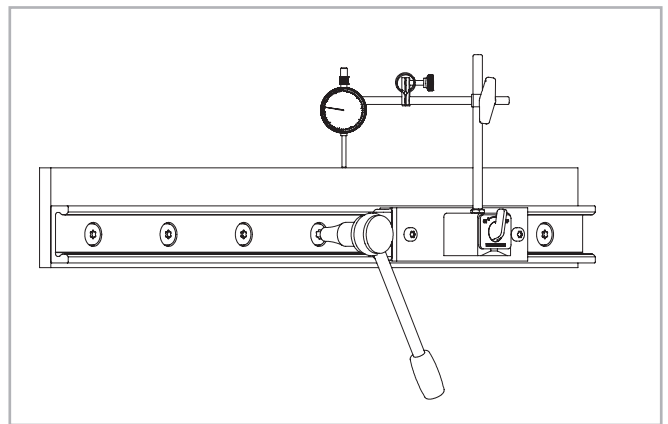

Fig. 68

(4) Begin to tighten the screws as specified while moving the slider together with the dial indicator. Make sure that it does not show any significant deflection. Repeat this procedure from the other end of the rail.

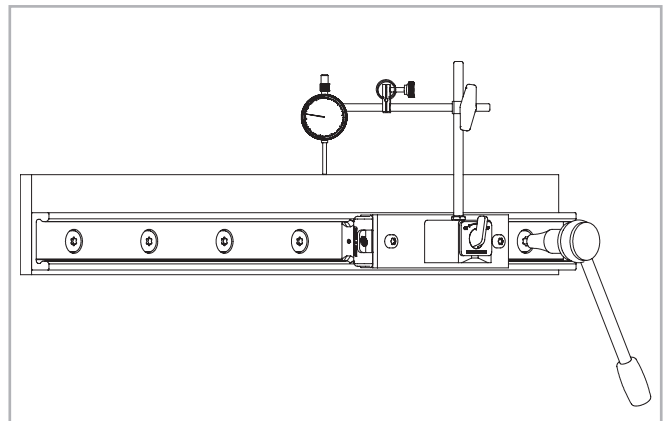

Fig. 69

> **Parallel installation of two rails**

When two rails with guiding sliders RV, a V+P system or a V+U system are installed the height difference of the two rails must not exceed a certain value (obtainable from the table below) in order to ensure proper guiding. These maximum values result from the maximum allowable twisting angle of the rollers in the raceways (see tab. 32). These values account for a load capacity reduction of 30% on the rail and must absolutely be maintained in every case.

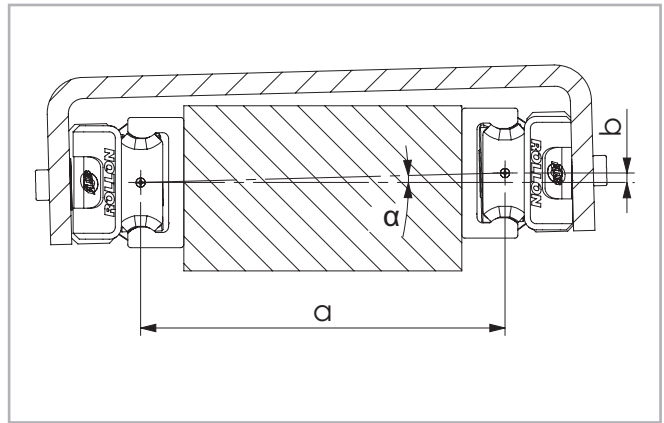

Fig. 70

Size	α
18	1 mrad (0.057°)
28	2.5 mrad (0.143°)
43	3 mrad (0.171°)

Tab. 32

When using two rails, the maximum parallelism deviation must not be exceeded (see tab. 33). Otherwise stresses can occur, which can result in a reduction in load capacity and service life.

Rail size	K1	K2
18	0.03	0.02
28	0.04	0.03
43	0.05	0.04

Tab. 33

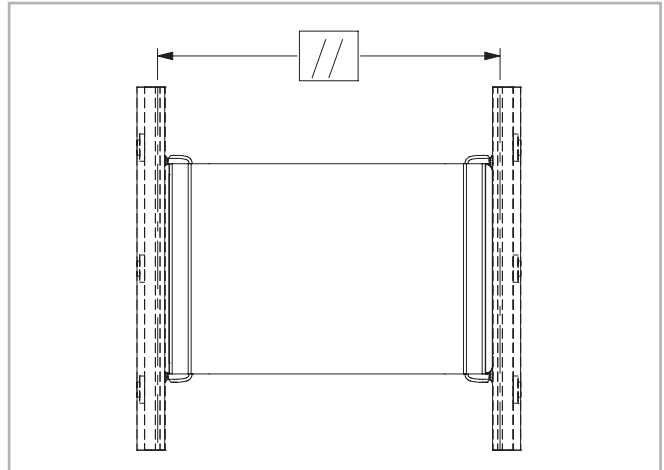

Fig. 71

Note: For parallelism problems, it is recommended to use a V+P/U or A+P/U system, since these combinations compensate for inaccuracies (see pg. CR-24, or CR-26).

Parallel installation of two rails

(1) Clean chips and dirt from the prepared mounting surfaces and fasten the first rail as described in the section on installation of a single rail.

(2) Fasten the second rail on the ends and the center. Tighten the screws in Position A and measure the distance between the raceways of the two rails.

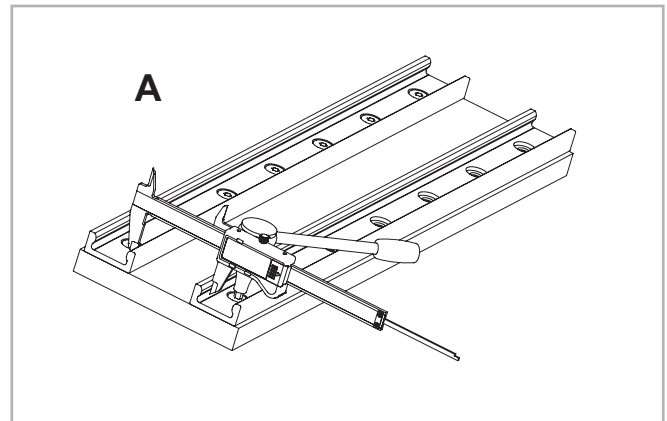

Fig. 72

(3) Fasten the rail in Position B so that the distance between the raceways does not exceed the measured values in Position A while maintaining the tolerances (see pg. CR-30, tab. 22) for parallel rail installation.

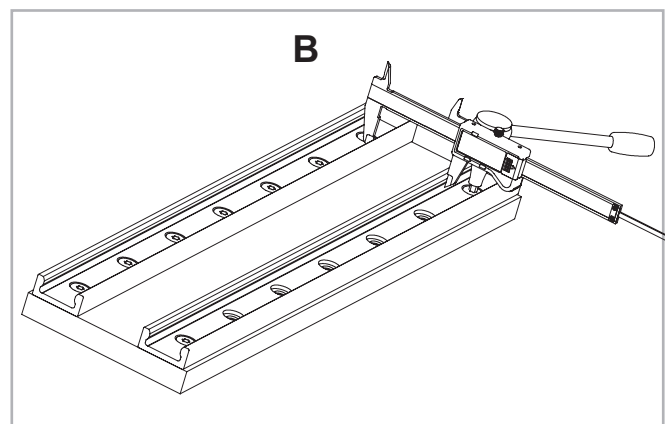

Fig. 73

(4) Fasten the screw in Position C so that the distance of the raceways is as close to an average between the two values from A and B as possible.

(5) Fasten all other screws and check the specified tightening torque of all fixing screws (see pg. CR-38, tab. 31).

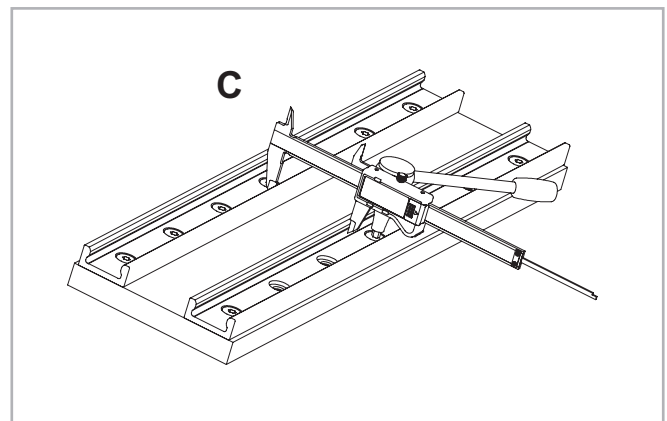

Fig. 74

> Installation of the self-aligning systems

When using a two-track parallel linear guide we recommend the use of a misalignment compensation system: the combination of a V+P/U sliders to compensate for deviations in parallelism or A+P/U sliders to compensate for deviations in parallelism in two planes.

Installation steps

(1) For a compensating system, the rail with the guiding slider RV is always installed first. This is then used as a reference for the compensating bearing rail.

Then proceed as described in the section on installation of a single rail (see pg. CR-37).

(2) Install the other bearing rail and only tighten the fixing screws slightly.

(3) Insert the sliders in the rails and install the element to be moved, without tightening its screws.

(4) Insert the element in the center of the rails and tighten it, use screws class 10.9.

(5) Tighten the center rail fixing screws to the specified torque (see pg.CR-38, tab. 31).

(6) Move the element to one end of the rail and start tightening the rest of the screws in the direction away from the slider.

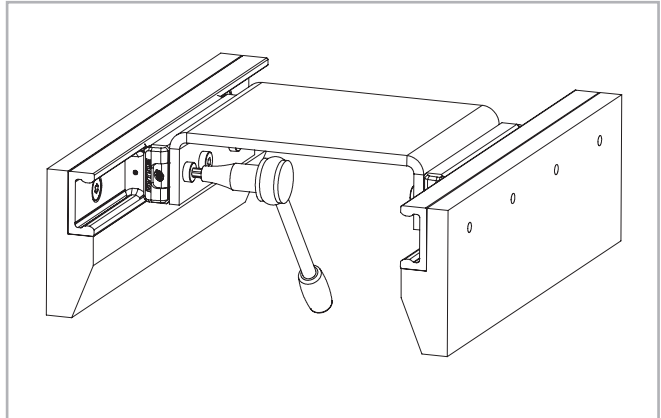

Fig. 75

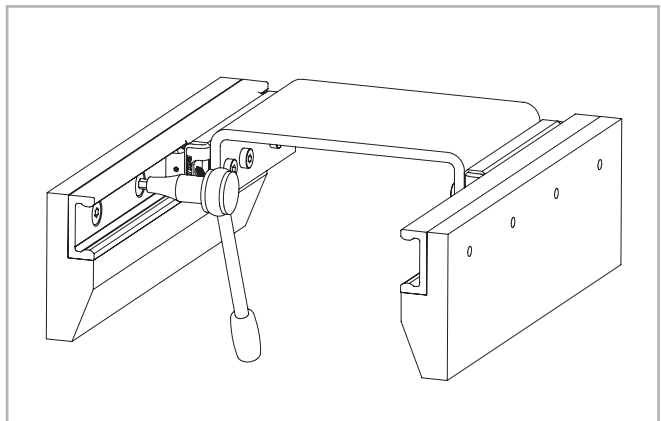

Fig. 76

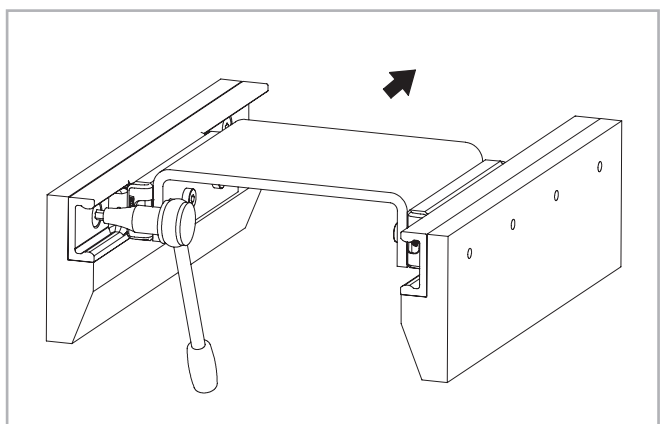

Fig. 77

> Joined Rails

If long guide rails are required, two or more rails can be joined to the desired length. When putting guide rails together, be sure that the register marks shown in fig. 78 are positioned correctly.

For applications with parallel joined guide rails we suggest them to be fabricated asymmetric.

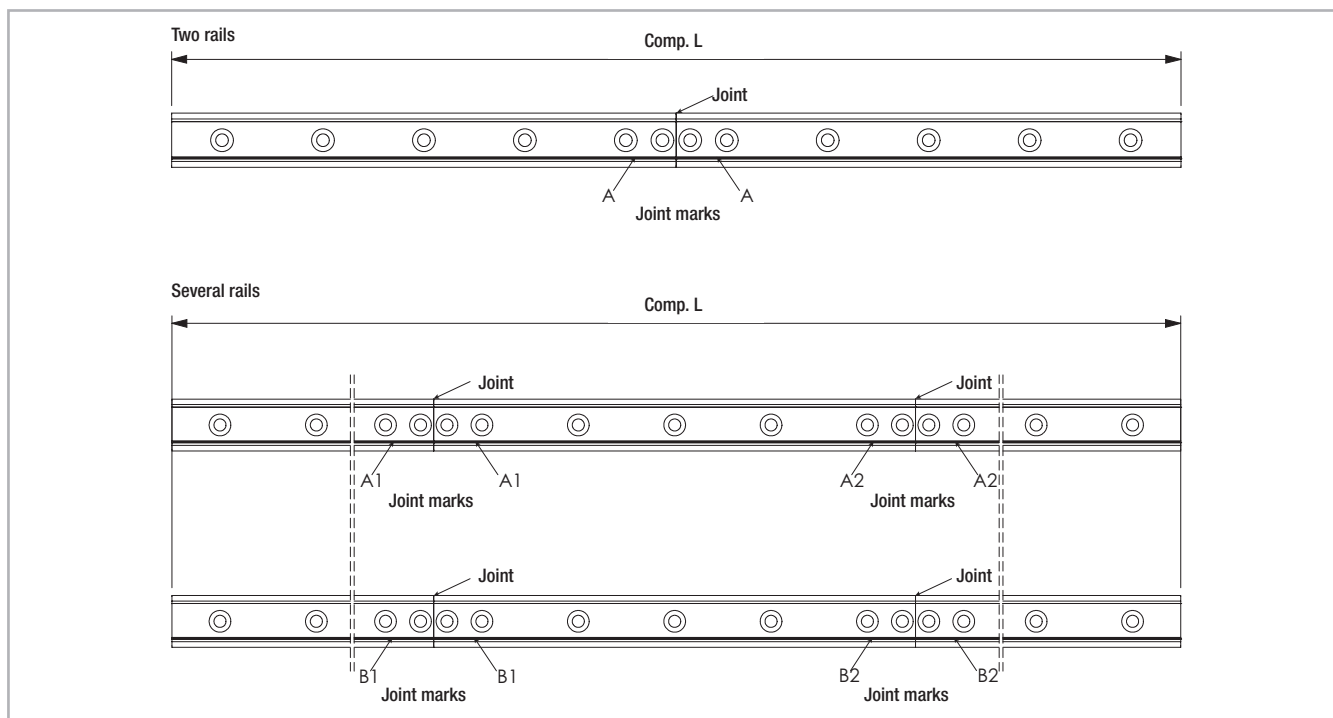

Fig. 78

General information

The maximum available rail length in one piece is indicated in table 5 on page CR-11. Longer lengths are achieved by joining two or more rails (joined rails).

Rollon then machines the rail ends at a right angle to the impact surfaces and marks them. Additional fixing screws are included with the delivery, which ensure a problem-free transition of the slider over the joints, if the following installation procedures are followed. Two additional threaded holes (see fig. 79) are required in the load-bearing structure. The included end fixing screws correspond to the installation screws for the rails for cylindrical counterbores (see pg. CR-34).

The alignment fixture for aligning the rail joint can be ordered using the designation given in the table (see pg. CR-19, tab. 11).

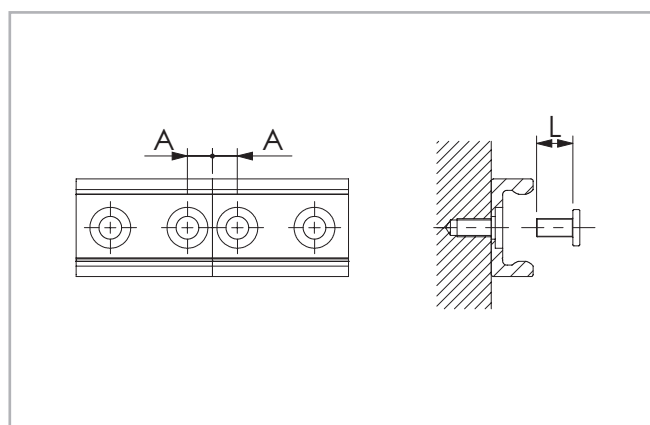

Fig. 79

Rail type	A [mm]	Threaded hole (load-bearing structure)	Screw type	L [mm]	Alignment fixture
TMGC18 - TMGV18	7	M4	see pg. CR-19	8	ATMG18
TGC28 - TGV28	8	M5		10	ATG28
TGC43 - TGV43	11	M8		16	ATG43

Tab. 34

> Installation of joined rails

After the fixing holes for the rails are made in the load-bearing structure, the joined rails can be installed according to the following procedure:

- (1) Fix the individual rails on the mounting surface by tightening all screws except for each last one on the rail joint.
- (2) Install the end fixing screws without tightening them (see fig. 80).

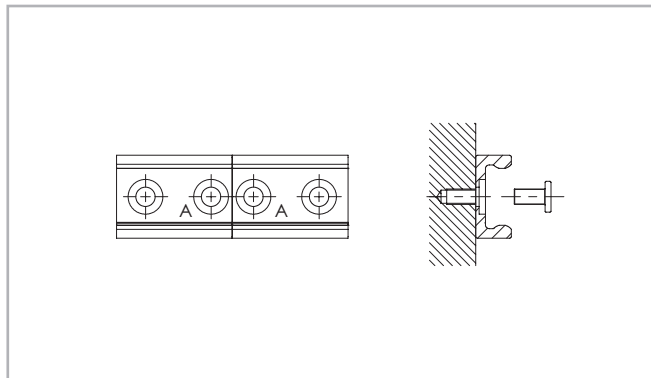

Fig. 80

- (3) Place the alignment fixture on the rail joint and tighten both set screws uniformly, until the raceways are aligned (see fig. 81).
- (4) After the previous step (3) it must be checked if both rail backs lie evenly on the mounting surface. If a gap has formed there, this must be shimmed.

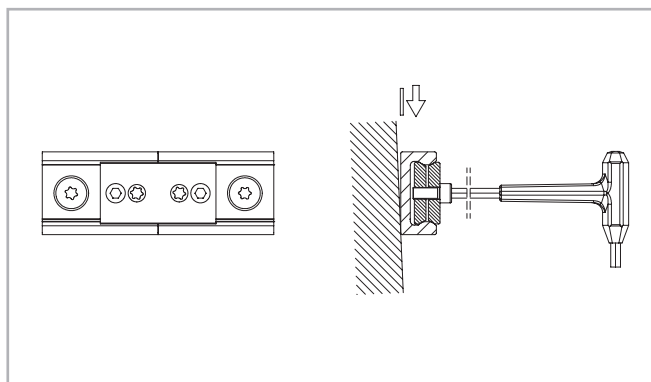

Fig. 81

- (5) The bottom of the rails should be supported in the area of the transition. Here a possible existing gap must be looked for, which must be closed for correct support of the rail ends by shims.

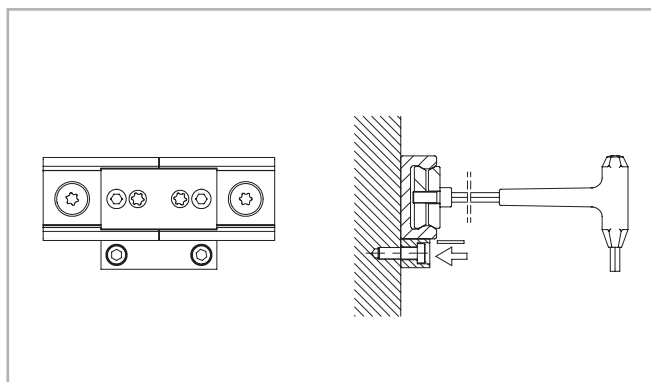

Fig. 82

- (6) Insert the key through the holes in the alignment fixture and tighten the screws on the rail ends.
- (7) For rails with 90° countersunk holes, tighten the remaining screws starting from the rail joint in the direction of the rail center. For rails with cylindrical counter-sunk holes, first adjust the rail to an external reference, then proceed as described above.
- (8) Remove the alignment fixture from the rail.

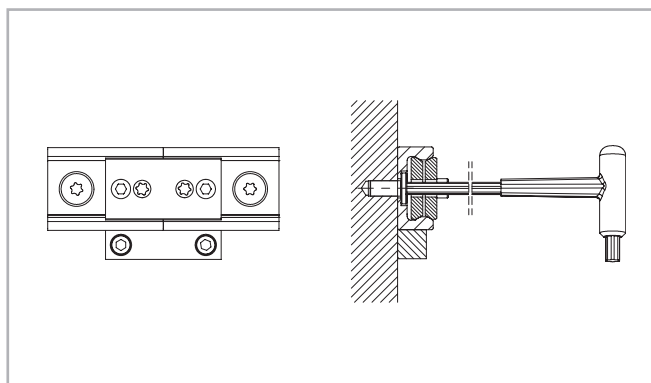

Fig. 83

Ordering key

Note on ordering: rails length codes are always 5 digits, sliders length codes are always 3 digits. Use zeroes as a prefix when lengths are shorter.

> Rail / slider system

TGV	-03600	/2/	RV	43G	-4	A	-N	
								Surface protection (if different from Standard) see pg. CR-33, tab. 24
								Configuration depending on type of slider see pg. CR-12 and CR-14
								Number of rollers see pg. CR-8, tab. 1
								Size see from pg. CR-11
								Slider type see pg. CR-12
								Number of sliders in one rail
								Rail length in mm see pg. CR-11, tab. 5
								Rail type see pg. CR-11, tab. 4

Ordering example: TGV-03600/2/RV43G-4A-N

> Rail

TGV	-43	-03600	-N	
				Surface protection (if different from Standard ISO 2081) see pg. CR-33, tab. 24
				Rail length in mm see pg. CR-11, tab. 5
				Size see pg. CR-11
				Rail type see pg. CR-11, tab. 5

Ordering examples: TGV-43-03600-N (single rail); TGV-43-05680-N (joined rails)

Rail composition: 1x880+2x2400 (only for joint processed rails)

Hole pattern: 40-10x80-40//40-29x80-40//40-29x80-40 (please always specify the hole pattern separately)

> Slider

RV	43G	-4	A	-N	
					Surface protection (if different from Standard) see pg. CR-33, tab. 24
					Configuration depending on type of slider see pgs. CR-12 and CR-14
					Number of rollers see pg. CR-8
					Size see pg. CR-11
					Slider type see pg. CR-12

Ordering example: RV43G-4A-N

> Wipers

ZK-WR	43G	
	Size	
		Wiper type see pg. CR-19

Ordering example: ZK-WR43G

Note on ordering: every kit contains a pair of wipers. Two wipers per slider are always required.