

ALMOTION

ROLLON®
BY TIMKEN

X-Rail



NEW

New X-Rail

A versatile linear guide in zinc-plated steel, stainless steel or hardened steel. It simplifies the project, improves the performance and reduces the application cost: **6 main advantages**



1

Self-aligning system

- Select the most suitable structure for your project
- Avoid machining the mounting surface
- Reduce the assembly time

Up to 3.5 mm
with T+U rails

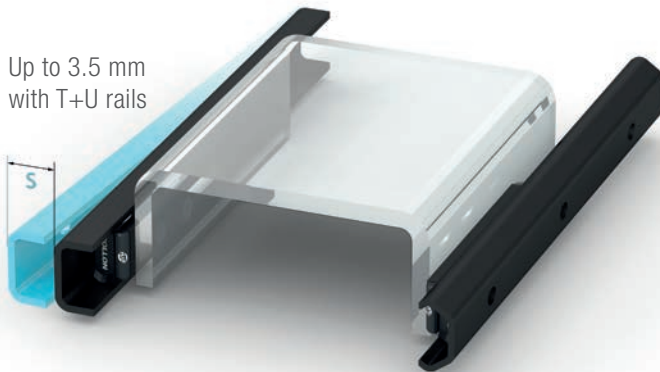

2

Cost effective rolled steel profile

High quality low carbon cold rolled steel profile with high yield strength



3

Resistant to corrosion

Different surface treatments and materials make X-Rail reliable in different application environments

- **Indoor applications:** zinc-plating ISO 2081, Rollon Nox
- **Outdoor applications:** stainless steel AISI 316L

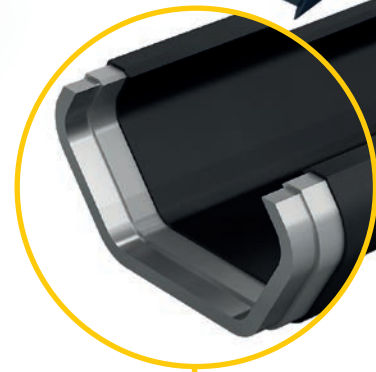



The best-performing series PLUS

Steel rails hardened with **Rollon-Nox treatment** of deep nitriding and oxidation for a longer lifetime and higher load capacities.

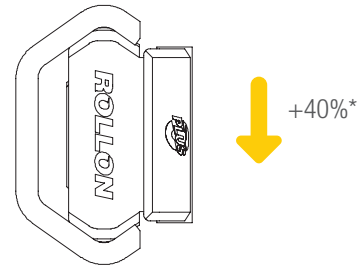

* Example referred to size 30.



4

Easy assembly

Easily mount the guide on non-machined structures, reducing total assembly time

Simple roller adjustment to regulate the sliding force perception in assembly phase



5

Optimal reliability in dirty environments

Newly designed polymer heads for an optimal cleaning of the raceways

Also available with slow release lubricating felt for low maintenance



6

Strength and sturdiness

Thanks to steel slider body

Product explanation



- > **X-Rail: linear bearings in stainless steel, zinc-plated steel or hardened steel with Rollon-Nox process.**



Fig. 1

X-Rail is the product family of roller embossed guide rails for applications in which an economical price to performance ratio and high corrosion resistance are required.

X-Rail linear guides features a rolled C-profile (0 degrees of axial play) or U-profile (1 degree of axial play) and are available in three versions: hardened with Rollon-Nox patented process of deep nitriding and oxidation (N/P-series), zinc-plated steel ISO 2081 (S-series) and stainless steel (X-series). Sizes range from 20 to 45 mm depending on the material of the guide and the type of profile. Every option features dedicated sliders, with compact or solid body.

The most important characteristics:

- Corrosion resistant, FDA/USDA compliant materials
- Compensates for deviations in mounting structure parallelism
- Optimal reliability in dirty environments thanks to internal raceways
- Wide range of operating temperature
- Easy adjustment of sliders

Preferred areas of application of the X-Rail product family:

- Construction and machine technology (e.g., safety doors, washing bay accessories)
- Medical technology (e.g., hospital accessories, medical equipment)
- Transport (e.g., rail transport, naval, automotive industry)
- Food and beverage industry (e.g., packaging, food processing)
- Building technology
- Energy technology (e.g., industrial furnaces, boilers)

N/P-series

Linear guides and sliders made of hardened steel. The Rollon-Nox hardening process provides the guide with long life and resistance to wear, in addition to a black surface resistant to flame and abrasion. Sliders feature newly designed polymer heads with slow release lubricating felt for low maintenance and an optimal cleaning of the raceways.



Fig. 2

S-series

Linear guides and sliders made of zinc-plated steel. They offer a simple and economical solution for a wide range of applications where high frequency is not required.

Good load capacity/size ratio, tailored designed sliders and ease of assembly are the features that make this product a winning choice compared to self-built or other similar solutions on the market.



Fig. 3

X-series

Linear guides and sliders in stainless steel AISI 316L (1.4404) and bearings in AISI 440 (1.4125). They offer a simple and practical solution for all applications where high corrosion resistance is required, in particular for food industry, chemical, pharmaceutical and medical industries. The product is easily washable for applications subject to frequent cleaning.

For applications in severe marine environments is available the electro-polished version for very high corrosion resistances.



Fig. 4

System (T+U-System)

T and U-rail can be used together for compensating deviations in parallelism and tolerances in the mounting structure. The T-rail (fixed rail) bears the main load while the U-rail with flat raceways (compensating rail) allows the bearings to travel axially without constraints.



Fig. 5

Rollers

Concentric and eccentric radial ball bearings made of stainless or roller bearing steel are available for each slider. Roller sealing is dependent on the material: 2RS rubber seals or 2Z steel shields. All rollers are lubricated for life.



Fig. 6

Technical data



Example of S-series / X-series

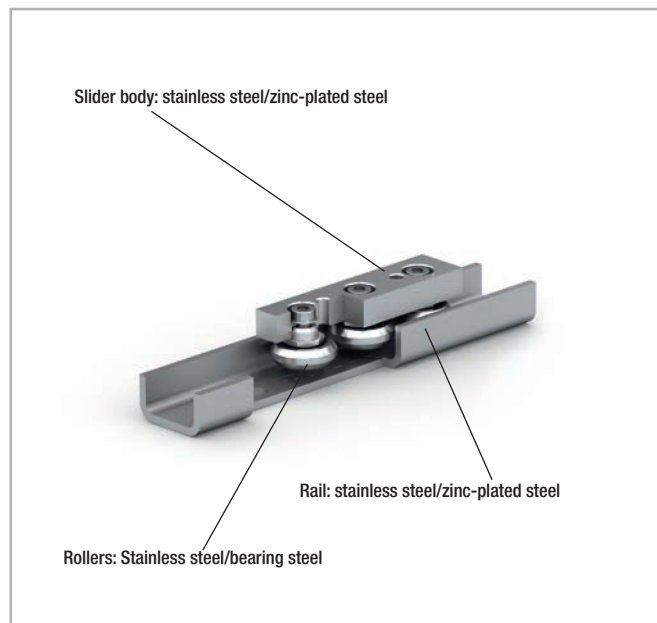

Fig. 7

Example of N/P-series

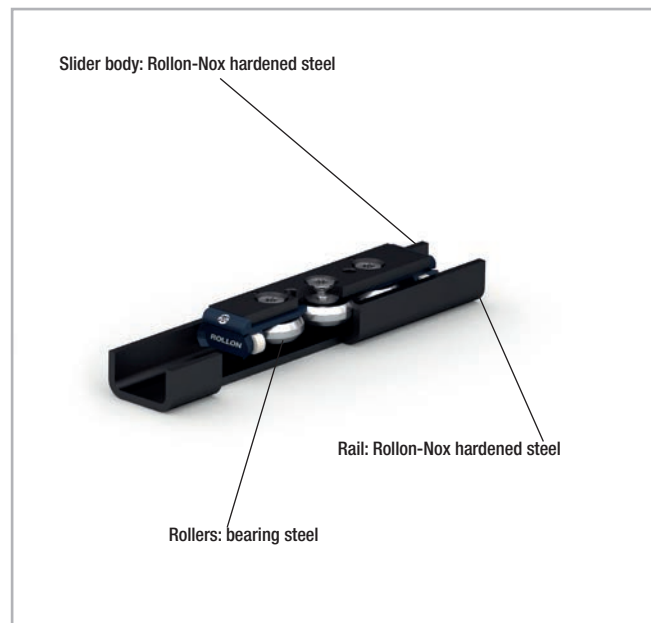

Fig. 8

Performance characteristics:

- Max. slider operating speeds in the linear bearing rails: 1.5 m/s (59 in/s) (depending on application)
- Max. acceleration: 2 m/s² (78 m/s²) (depending on application)
- Available rail lengths: from 160 mm to 4000 mm (from 6,3 in to 157 in) in 80 mm increments (3,15 in).
- Rollers lubricated for life

N/P-Series

- Available sizes: 26-30-40 type T, 30-40 type U
- Max. radial load capacity: 3240 N
- Operating temperature range: -20 °C to +120 °C (-4°F to +248°F)
- Rail material: S420MC steel hardened with Rollon-Nox patented process
- Rollers material: carbon steel with 2Z shield (dust cover seal)

S-Series

- Available sizes: 20-26-30-40-45 type T, 30-40-45 type U
- Max. radial load capacity: 1740 N
- Operating temperature range: -20 °C to +120 °C (-4°F to +248°F)
- Rail material: S420MC (size 26-30-40) or S355MD (size 20-45) zinc-plated steel ISO 2081
- Rollers material: carbon steel with 2Z shield (dust cover seal)

X-Series

- Available sizes: 20-26-30-40-45 type T, 30-40-45 type U
- Max. radial load capacity: 1600 N
- Operating temperature range: -20 °C to +100°C (-4 °F to +212 °F)
- Rail material: stainless steel AISI 316L (1.4404)
- Rollers material: stainless steel AISI 440 (1.4125) with 2RS shield (splashproof seal)

Remarks:

- The sliders are equipped with rollers that are in alternating contact with both sides of the raceway. Markings on the body around the outer roller pins indicate the correct arrangement of the rollers to the external load.
- All the rails are engraved with a tracking code that identifies the production batch.
- With a simple adjustment of the eccentric roller, clearance or the desired preload can be set on the rail and slider.
- Different sliders are available depending on the type and the size of the linear guide. Refer to every chapter for details.
- We do not recommend combining (join together) the rails.
- Recommended fixing screws: ISO 7380 with low head height (special TORX® screws are available on request).
- Do not use in applications with high number of cycles. For further information, please contact Rollon Technical Department.

> Load capacities

Fixed bearings type T

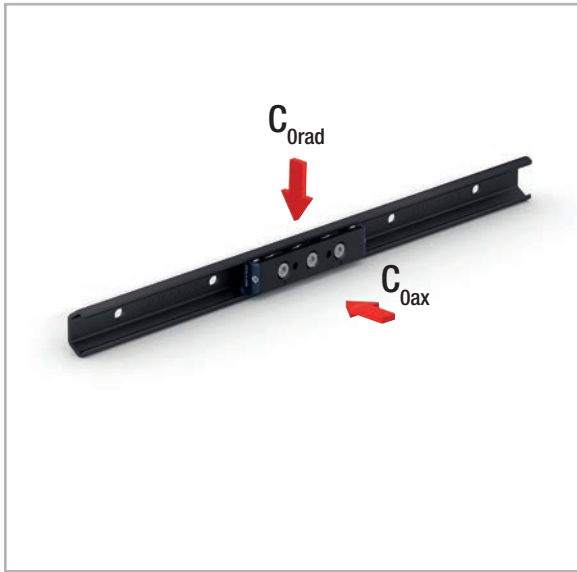

Fig. 9

Rail type	Configuration	No. of rollers	C_{Orad} [N]	C_{Oax} [N]	Dynamic coefficient C [N]
TEN/TEP	TEN26 - CEN26-92T	3	1120	380	1280
	TEN26 - CEN26-142T	5	1520	540	1730
	TEP30 - CEP30-3T	3	1200	420	1360
	TEP30 - CEP30-5T	5	1620	580	1830
	TEN40 - CEN40-135T	3	2400	820	2720
	TEN40 - CEN40-195T	5	3240	1150	3670
TES	TES20 - CES20-...	3	326	185	-
	TES26 - CES26-80	3	800	400	-
	TES30 - CES30...	3	870	435	-
	TES40 - CES40-135	3	1600	800	-
	TES45 - CES45...	3	1740	935	-
TEX	TEX20 - CEX20-...	3	300	170	-
	TEX26 - CEX26-80	3	740	370	-
	TEX30 - CEX30...	3	800	400	-
	TEX40 - CEX40-135	3	1470	740	-
	TEX45 - CEX45...	3	1600	860	-

Resulting moment loads must be absorbed through the use of two sliders

Tab. 1

Compensating bearings type U

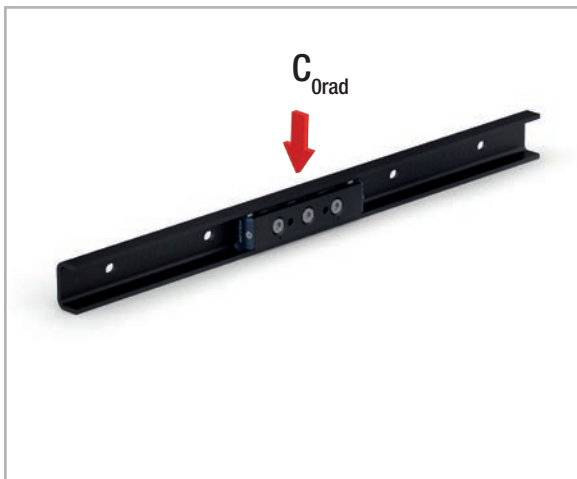

Fig. 10

Rail type	Configuration	No. of rollers	C_{Orad} [N]	Dynamic coefficient C [N]
UEN/UEP	UEP30 - CEP30-3T	3	1200	1360
	UEP30 - CEP30-5T	5	1620	1830
	UEN40 - CEN40-135T	3	1900	2720
	UEN40 - CEN40-195T	5	2560	3670
UES	UES30 - CESU30-80	3	870	-
	UES40 - CES40-135	3	1600	-
	UES45 - CESU45-120	3	1740	-
UEX	UEX30 - CEXU30-80	3	800	-
	UEX40 - CEX40-135	3	1180	-
	UEX45 - CEXU45-120	3	1600	-

Tab. 2

Product dimensions



TEN/TEP - Rollon-Nox hardened steel guides with shaped raceways

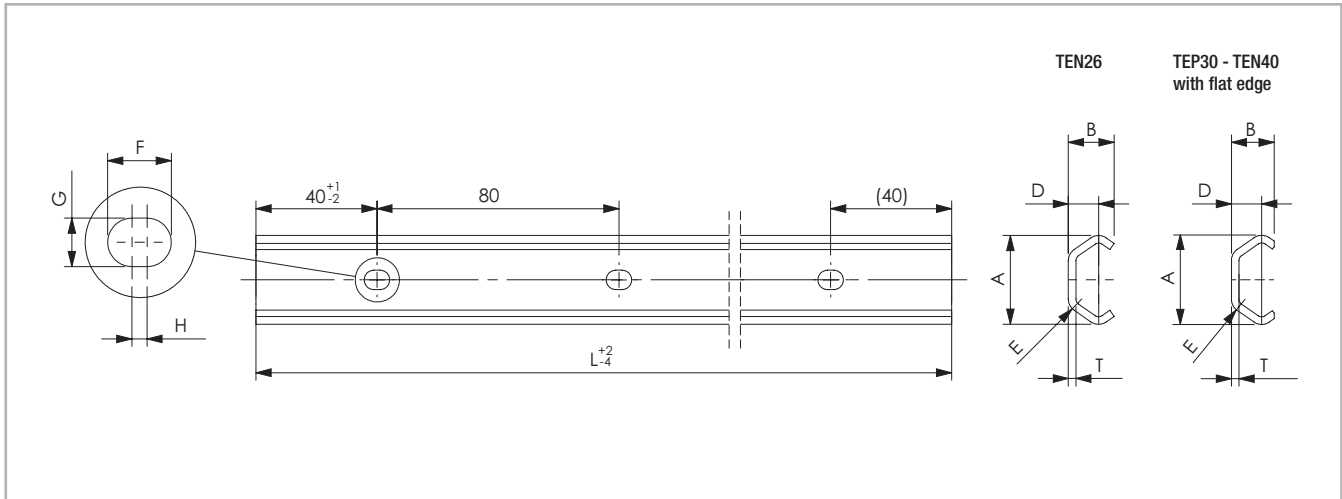

Fig. 11

Rail type	Size	A [mm]	B [mm]	T [mm]	D [mm]	E [mm]	F [mm]	G [mm]	H [mm]	Holes for screws	Weight [kg/m]
TEN	26	26.1	14	2.5	9.5	4.5	11	6	5	M5	0.80
TEP	30	29.5	14.1	2.5	10	4.5	11	6	5	M5	0.95
TEN	40	39.5	20	3	13	6	13	9	4	M8	1.55

Tab. 3

Rail type	Size	Min length [mm]	Max length [mm]	Standard length L [mm]
TEN	26	160	4000	160 - 240 - 320 - 400 - 480 - 560 - 640 - 720 - 800 - 880 - 960 - 1040 - 1120 - 1200 - 1280 - 1360 - 1440 - 1520 - 1600 - 1680 - 1760 - 1840 - 1920 - 2000 - 2080 - 2160 - 2240 - 2320 - 2400 - 2480 - 2560 - 2640 - 2720 - 2800 - 2880 - 2960 - 3040 - 3120 - 3200 - 3280 - 3360 - 3440 - 3520 - 3600 - 3680 - 3760 - 3840 - 3920 - 4000
TEP	30	160	4000	
TEN	40	160	4000	

Please specify hole pattern separately
 Special lengths or pitches available upon request, please contact the sales department
 The highlighted rail length are available from stock

Tab. 4

CEN26 slider for rail TEN26

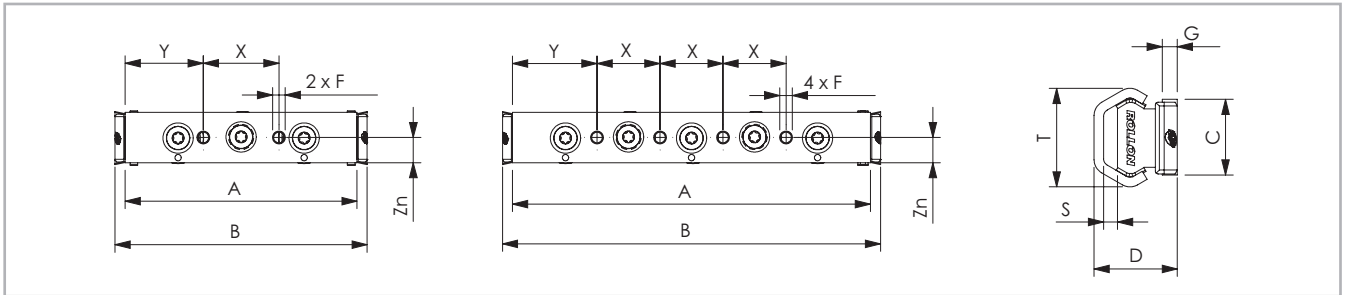

Fig. 12

Slider type	No. of rollers	A [mm]	B [mm]	C [mm]	D [mm]	F	G [mm]	S [mm]	T [mm]	X [mm]	Y [mm]	Zn [mm]	Weight [kg]
CEN26-92T	3	92	100	20	22	M5	4	3.7	26.1	30	31	10	0.11
CEN26-142T	5	142	150							33.5	25		0.15

Tab. 5

CEP30 slider for rail TEP 30

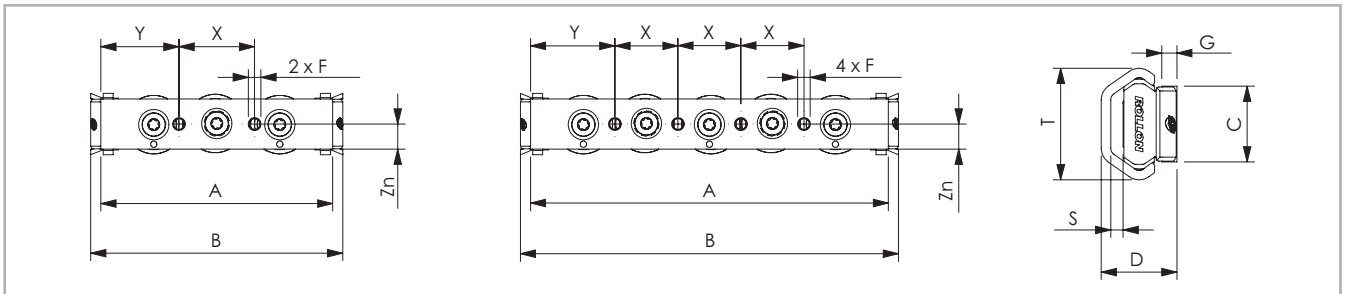

Fig. 13

Slider type	No. of rollers	A [mm]	B [mm]	C [mm]	D [mm]	F	G [mm]	S [mm]	T [mm]	X [mm]	Y [mm]	Zn [mm]	Weight [kg]
CEP30-3T	3	92	100	20	20	M5	4	3.3	29.5	30	31	10	0.13
CEP30-5T	5	142	150							25	33.5		0.17

Tab. 6

CEN40 slider for rail TEN40

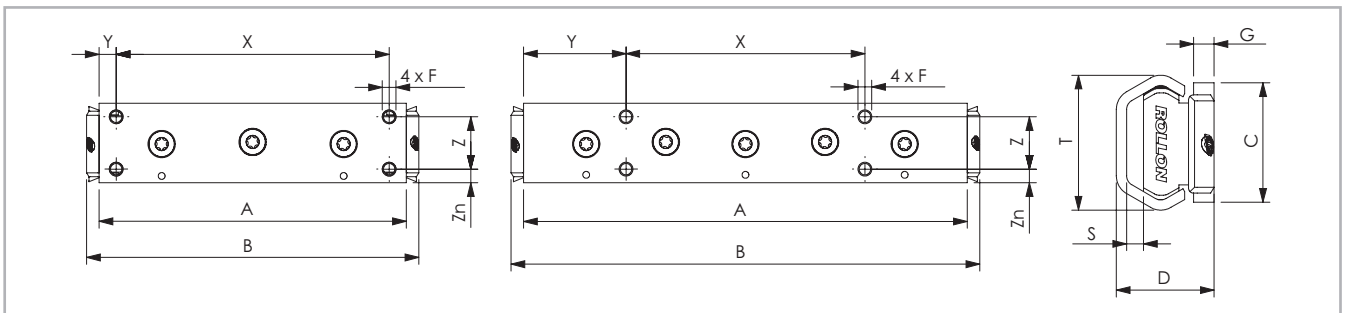

Fig. 14

Slider type	No. of rollers	A [mm]	B [mm]	C [mm]	D [mm]	F	G [mm]	S [mm]	T [mm]	X [mm]	Y [mm]	Z [mm]	Zn [mm]	Weight [kg]
CEN40-135T	3	135	146	35	28.65	M6	6	5	39.5	120	7.5	23	6	0.45
CEN40-195T	5	195	206							105	45			0.62

Tab. 7

> UEN/UEP - Rollon-Nox hardened steel guides with flat raceways

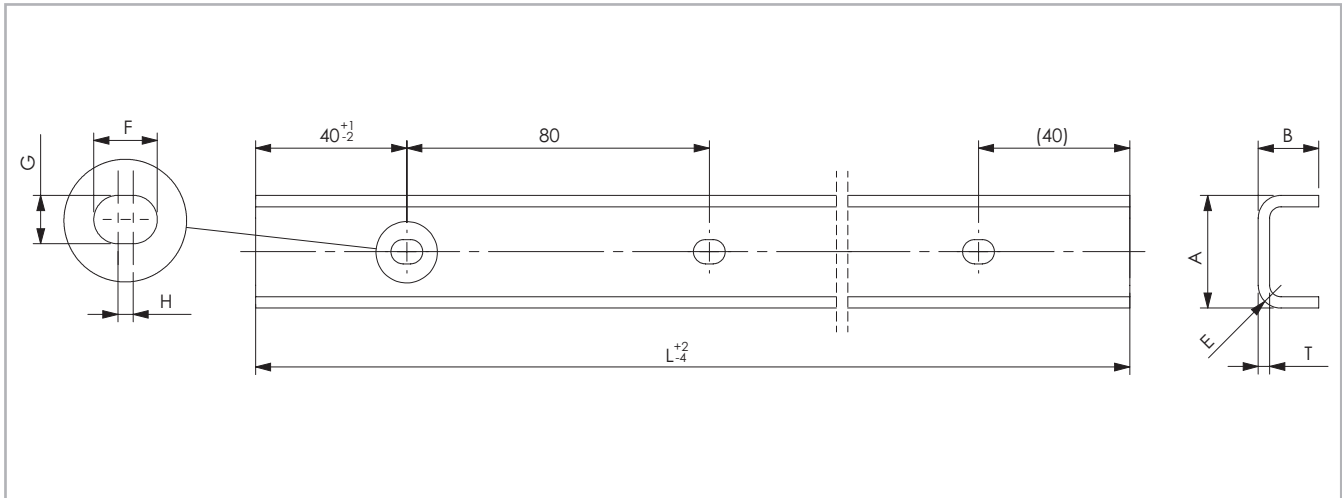

Fig. 15

Rail type	Size	A [mm]	B [mm]	T [mm]	E [mm]	F [mm]	G [mm]	H [mm]	Holes for screws	Weight [kg/m]
UEP	30	29.8	16	3	6	11	6	5	M5	1.19
UEN	40	38.5	21	3	6	13	9	4	M8	1.70

Tab. 8

Rail type	Size	Min length [mm]	Max length [mm]	Standard length L [mm]
UEP	30	160	4000	160 - 240 - 320 - 400 - 480 - 560 - 640 - 720 - 800 - 880 - 960 - 1040 - 1120 - 1200 - 1280 - 1360 - 1440 - 1520 - 1600 - 1680 - 1760 - 1840 - 1920 - 2000 - 2080 - 2160 - 2240 - 2320 - 2400 - 2480 - 2560 - 2640
UEN	40	160	4000	- 2720 - 2800 - 2880 - 2960 - 3040 - 3120 - 3200 - 3280 - 3360 - 3440 - 3520 - 3600 - 3680 - 3760 - 3840 - 3920 - 4000

Please specify hole pattern separately
 Special lengths or pitches available upon request, please contact the sales department
 The highlighted rail lengths are available from stock

Tab. 9

CEP30 slider for rail UEP30

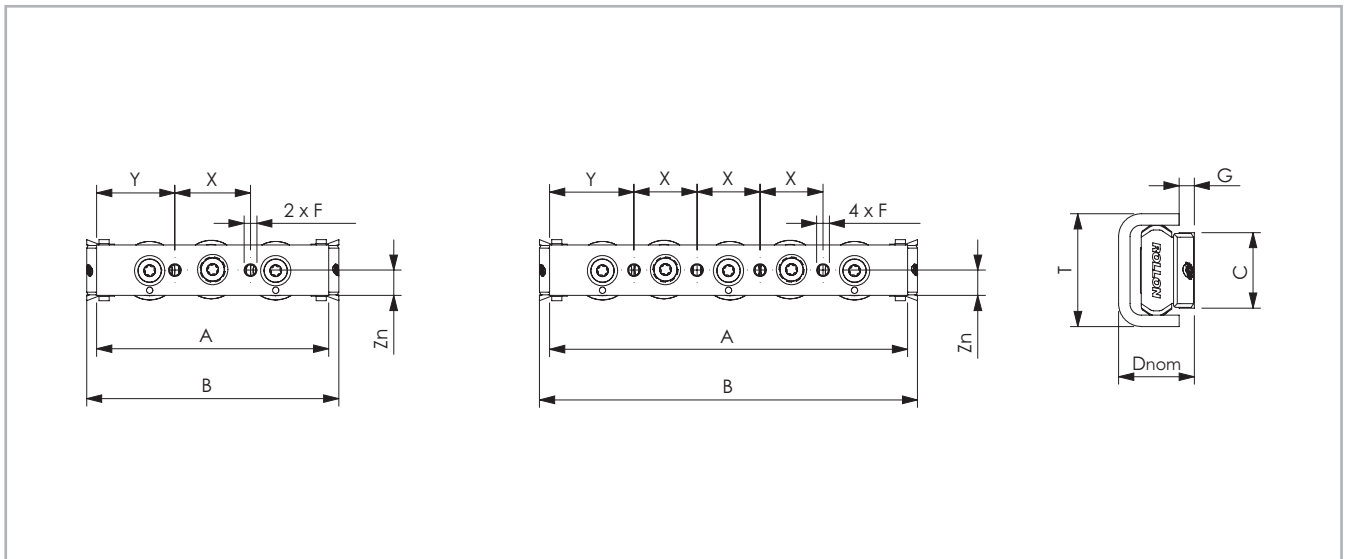

Fig. 16

Slider type	No. of rollers	A [mm]	B [mm]	C [mm]	D _{nom} [mm]	F	G [mm]	T [mm]	X [mm]	Y [mm]	Zn [mm]	Weight [kg]
CEP30-3T	3	92	100	20	21.1 ±0.6	M5	4	29.8	30	31	10	0.13
CEP30-5T	5	142	150						25	33.5		0.17

Tab. 10

CEN40 slider for rail UEN40

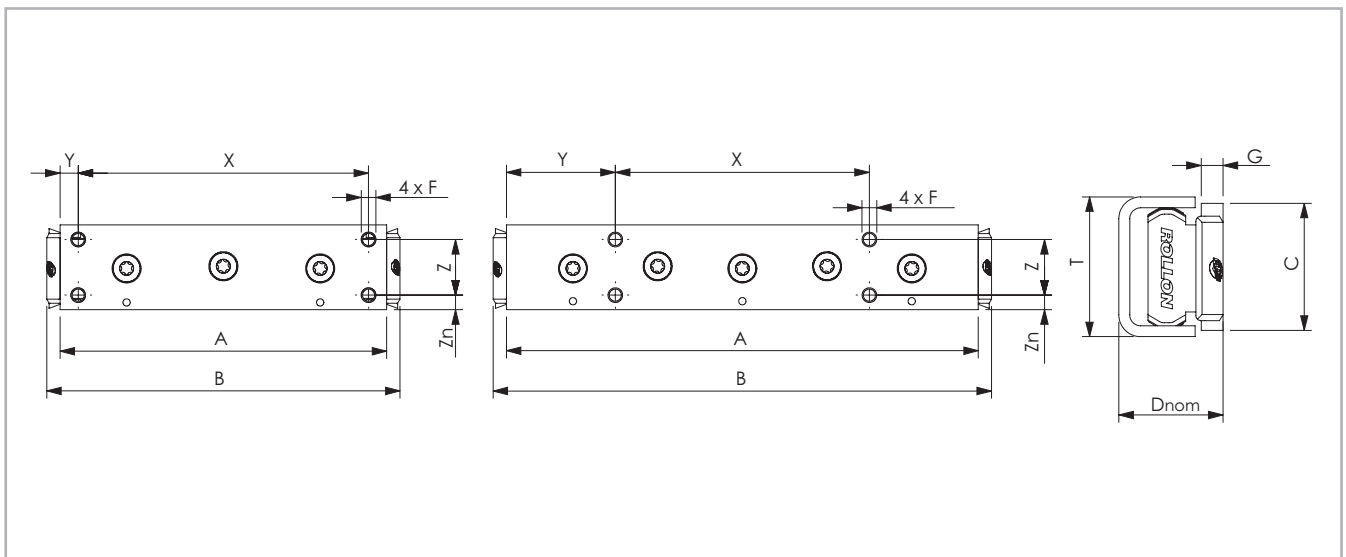

Fig. 17

Slider type	No. of rollers	A [mm]	B [mm]	C [mm]	D _{nom} [mm]	F	G [mm]	T [mm]	X [mm]	Y [mm]	Z [mm]	Zn [mm]	Weight [kg]
CEN40-135T	3	135	146	35	29.95 ±1.6	M6	6	38.5	120	7.5	23	6	0.45
CEN40-195T	5	195	206						105	45			0.62

Tab. 11

X
R

> TES - Zinc-plated steel guides with shaped raceways

TES rail in zinc-plated steel

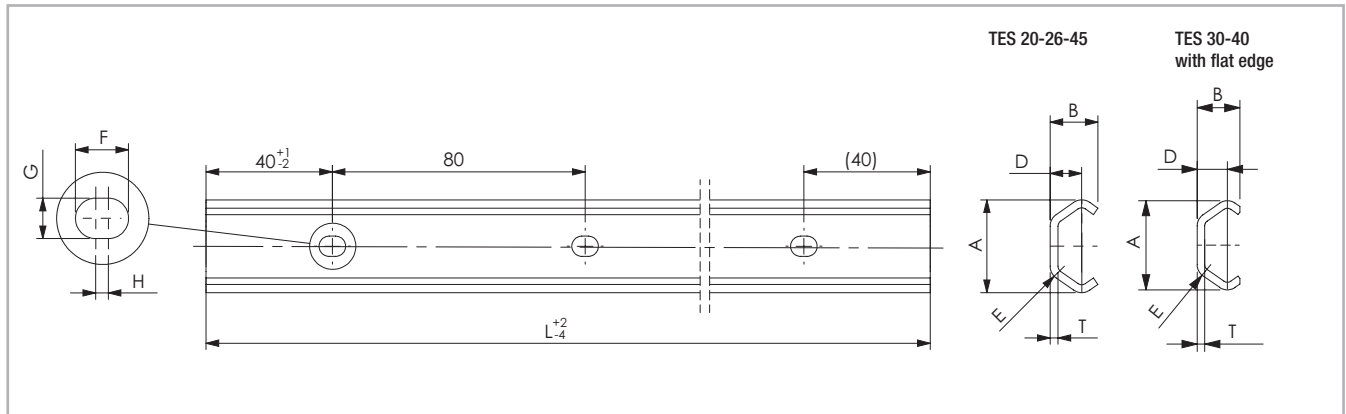

Fig. 18

Rail type	Size	A [mm]	B [mm]	T [mm]	D [mm]	E [mm]	F [mm]	G [mm]	H [mm]	Holes for screws	Weight [kg/m]
TES	20	19.2	10.2	2	6.9	3	7	4.5	2.5	M4	0.47
	26	26.1	14	2.5	9.5	4.5	11	6	5	M5	0.80
	30	29.5	14.1	2.5	10	4.5	11	6	5	M5	0.90
	40	39.5	20	3	13	6	13	9	4	M8	1.55
	45	46.4	24	4	15.5	6.5	11	9	2	M8	2.29

Tab. 12

Rail type	Size	Min length [mm]	Max length [mm]	Standard length L [mm]
TES	20	160	3120	160 - 240 - 320 - 400 - 480 - 560 - 640 - 720 - 800 - 880 - 960 - 1040 - 1120 - 1200 - 1280 - 1360 - 1440 - 1520 - 1600 - 1680 - 1760 - 1840 - 1920 - 2000 - 2080 - 2160 - 2240 - 2320 - 2400 - 2480 - 2560 - 2640 - 2720 - 2800 - 2880 - 2960 - 3040 - 3120 - 3200 - 3280 - 3360 - 3440 - 3520 - 3600 - 3680 - 3760 - 3840 - 3920 - 4000
	26	160	4000	
	30	160	4000	
	40	160	4000	
	45	320	4000	

Please specify hole pattern separately
 Special lengths or pitches available upon request, please contact the sales department
 The highlighted rail lengths are available from stock (3120 only for TES 20)

Tab. 13

CES20 slider for rail TES 20

CES20-80 with compact body and wipers

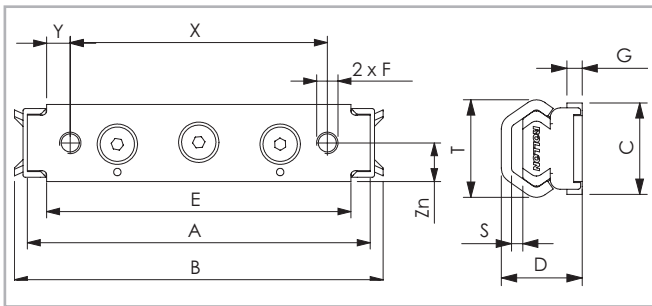

Fig. 19

CES20-60 with solid body (wipers on request)

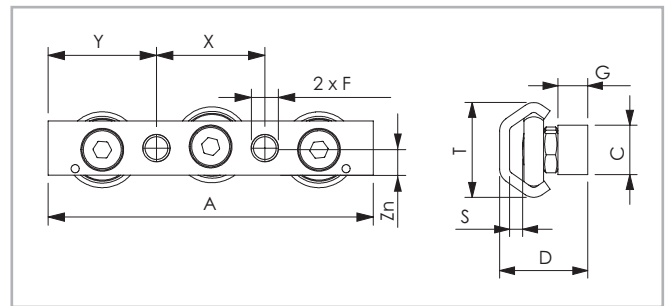

Fig. 20

Slider type	No. of rollers	A [mm]	B [mm]	C [mm]	D [mm]	E [mm]	F	G [mm]	S [mm]	T [mm]	Zn [mm]	X [mm]	Y [mm]	Weight [kg]
CES20-80	3	80	86	18	15.9	71	M5	5.5	2.2	19.2	9	60	5.5	0.05
CES20-60		60	-	10	17.8	-	M5	6	2.6	19.2	5	20	20	0.04

Tab. 14

CES26 slider for rail TES 26

CES26-80 with compact body (wipers not available)

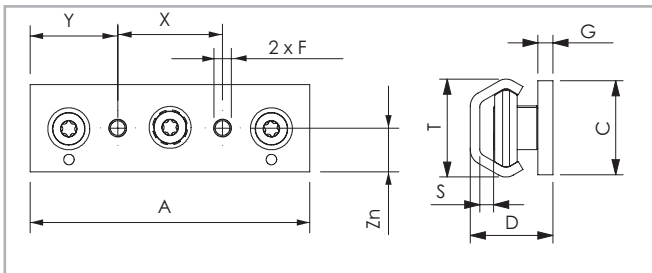

Fig. 21

Slider type	No. of rollers	A [mm]	C [mm]	D [mm]	F	G [mm]	S [mm]	T [mm]	X [mm]	Y [mm]	Zn [mm]	Weight [kg]
CES26-80	3	80	25	22	M5	4	3.7	26.1	30	25	12.5	0.095

Tab. 15

CES30 slider for rail TES 30

CES30-88 with compact body and wipers

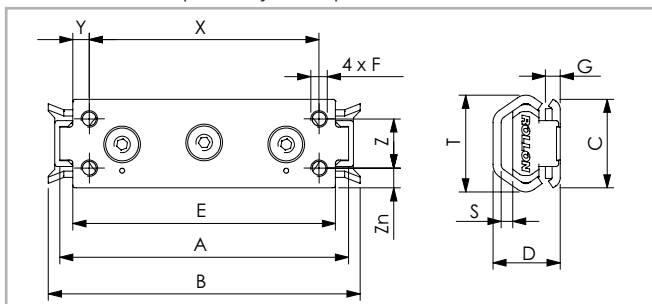

Fig. 22

CES30-80 with solid body (wipers on request)

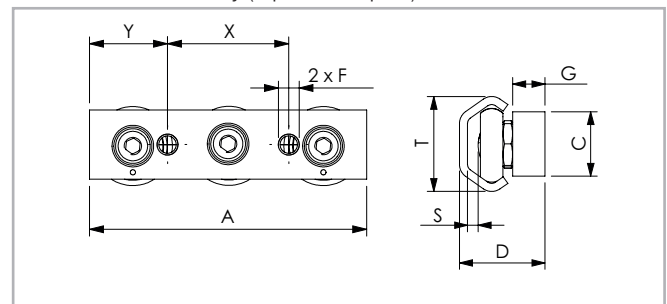

Fig. 23

Slider type	No. of rollers	A [mm]	B [mm]	C [mm]	D [mm]	E [mm]	F	G [mm]	S [mm]	T [mm]	Z [mm]	Zn [mm]	X [mm]	Y [mm]	Weight [kg]
CES30-88	3	88	95	27	20.5	80	M5	4.5	3.5	29.5	15	6	70	5	0.11
CES30-80		80	-	20	26.5	-	M6	10	3.3	29.5	-	10	35	22.5	0.17

Tab. 16

3 Product dimensions

CES40 slider for rail TES 40

CES40-135 with compact body (wipers on request)

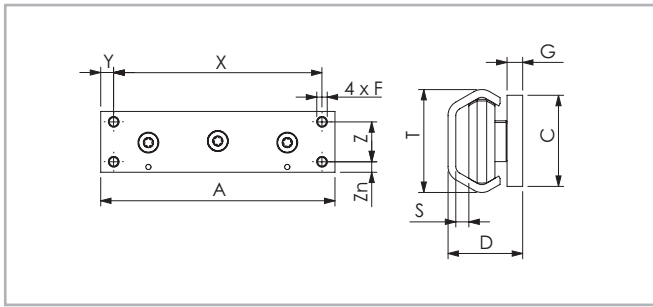

Fig. 24

Slider type	No. of rollers	A [mm]	C [mm]	D [mm]	F	G [mm]	S [mm]	T [mm]	X [mm]	Y [mm]	Z [mm]	Zn [mm]	Weight [kg]
CES40-135	3	135	35	28.65	M6	6	5	39.5	120	7.5	23	6	0.450

Tab. 17

CES45 slider for rail TES 45

CES45-150 with compact body and wipers

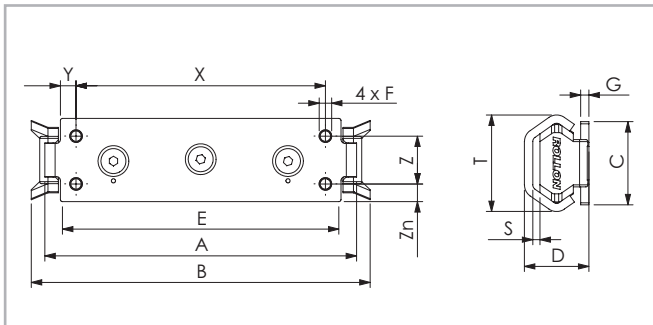

Fig. 25

CES45-120 with solid body (wipers on request)

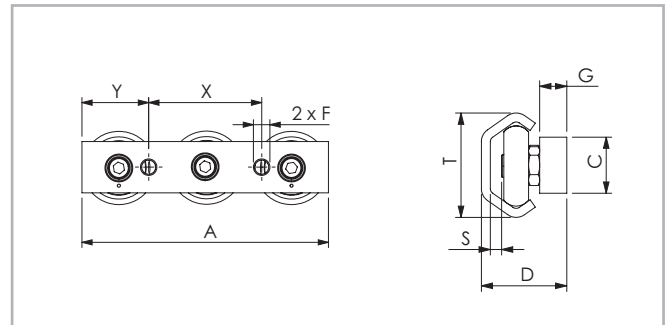

Fig. 26

Slider type	No. of rollers	A [mm]	B [mm]	C [mm]	D [mm]	E [mm]	F	G [mm]	S [mm]	T [mm]	Z [mm]	Zn [mm]	X [mm]	Y [mm]	Weight [kg]
CES45-150	3	150	160	40	31	135	M6	4	5	46.4	23	8.5	120	7.5	0.40
CES45-120		120	-	25	38	-	M8	12	5.7	46.4	-	12.5	55	32.5	0.45

Tab. 18

> UES - Zinc-plated steel guides with flat raceways

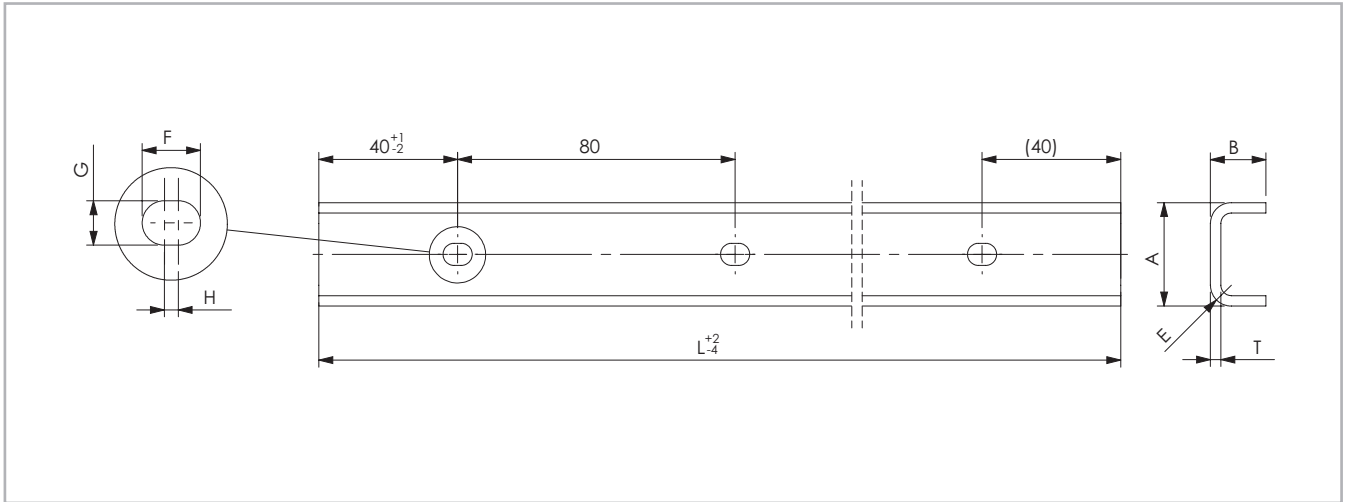

Fig. 27

Rail type	Size	A [mm]	B [mm]	T [mm]	E [mm]	F [mm]	G [mm]	H [mm]	Holes for screws	Weight [kg/m]
UES	30	29.8	16	3	6	11	6	5	M5	1.39
	40	38.5	21	3	6	13	9	4	M8	1.7
	45	43.8	24.5	4	9	11	9	2	M8	2.79

Tab. 19

Rail type	Size	Min length [mm]	Max length [mm]	Standard length L [mm]
UES	30	160	4000	160 - 240 - 320 - 400 - 480 - 560 - 640 - 720 - 800 - 880 - 960 - 1040 - 1120 - 1200 - 1280 - 1360 - 1440 - 1520 - 1600 - 1680 - 1760 - 1840 - 1920 - 2000 - 2080 - 2160 - 2240 - 2320 - 2400 - 2480 - 2560 - 2640 - 2720 - 2800 - 2880 - 2960 - 3040 - 3120 - 3200 - 3280 - 3360 - 3440 - 3520 - 3600 - 3680 - 3760 - 3840 - 3920 - 4000
	40	160	4000	
	45	320	4000	

Please specify hole pattern separately
 Special lengths or pitches available upon request, please contact the sales department
 The highlighted rail lengths are available from stock

Tab. 20

3 Product dimensions

CESU30 slider for rail UES 30

CESU30-80 with solid body (wipers on request)

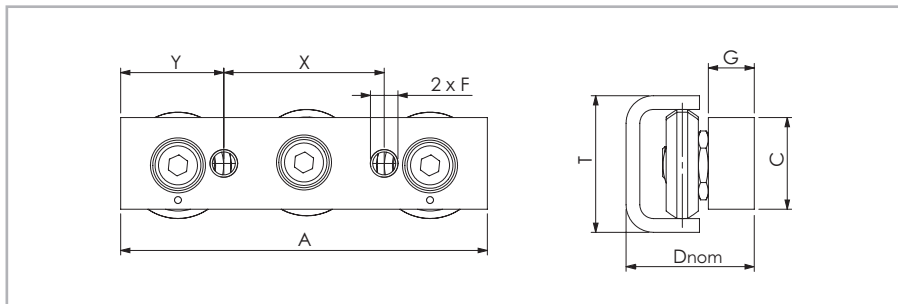

Fig. 28

Slider type	No. of rollers	A [mm]	C [mm]	D _{nom} [mm]	F	G [mm]	T [mm]	X [mm]	Y [mm]	Weight [kg]
CESU30-80	3	80	20	27.95 ± 0.6	M6	10	29.8	35	22.5	0.16

Tab. 21

CES40 slider for rail UES 40

CES40-135 with compact body (wipers on request)

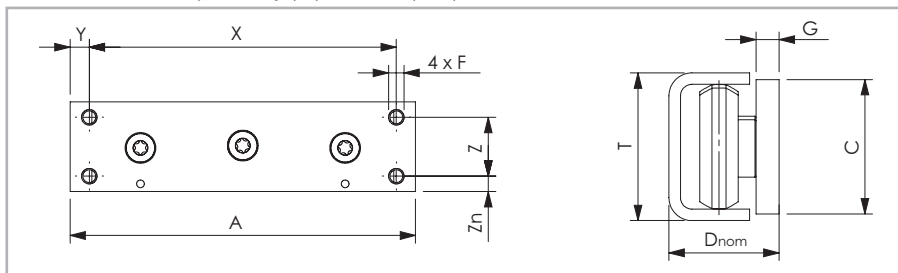

Fig. 29

Slider type	No. of rollers	A [mm]	C [mm]	D _{nom} [mm]	F	G [mm]	T [mm]	Z [mm]	Zn [mm]	X [mm]	Y [mm]	Weight [kg]
CES40-135	3	135	35	29.95 ± 1.6	M6	6	38.5	23	8	120	7.5	0.45

Tab. 22

CESU45 slider for rail UES 45

CESU45-120 with solid body (wipers on request)

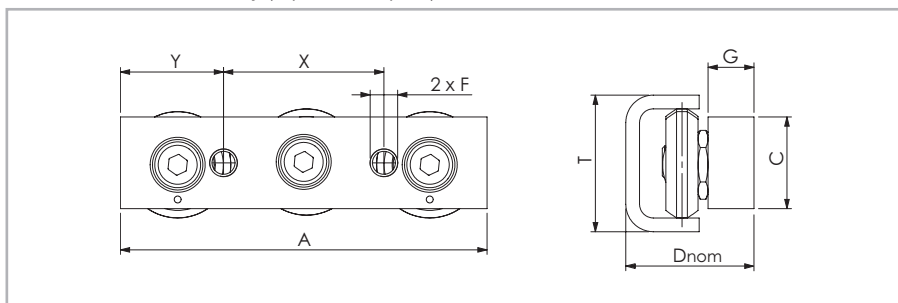

Fig. 30

Slider type	No. of rollers	A [mm]	C [mm]	D _{nom} [mm]	F	G [mm]	T [mm]	X [mm]	Y [mm]	Weight [kg]
CESU45-120	3	120	25	37.25 ± 1.75	M8	12	43.8	55	32.5	0.45

Tab. 23

> **TEX - Stainless steel guides with shaped raceways**

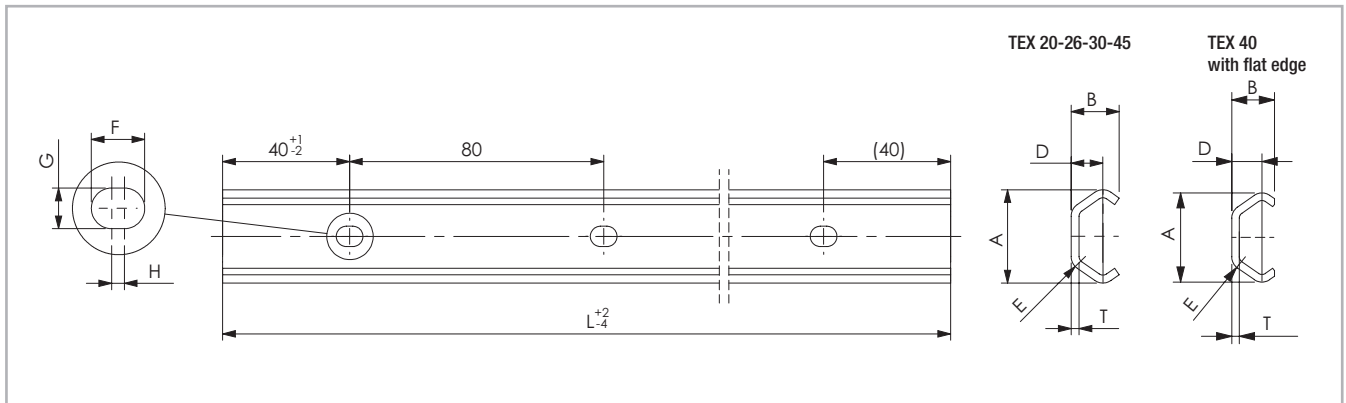

Fig. 31

Rail type	Size	A [mm]	B [mm]	T [mm]	D [mm]	E [mm]	F [mm]	G [mm]	H [mm]	Holes for screws	Weight [kg/m]
TEX	20	19.2	10.2	2	6.9	3	7	4.5	2.5	M4	0.47
	26	26.1	14	2.5	9.5	4.5	11	6	5	M5	0.80
	30	29.5	15	2.5	10	4.5	11	6	5	M5	0.90
	40	39.5	20	3	13	6	13	9	4	M8	1.55
	45	46.4	24	4	15.5	6.5	11	9	2	M8	2.29

Tab. 24

Rail type	Size	Min length [mm]	Max length [mm]	Standard length L [mm]
TEX	20	160	3120	160 - 240 - 320 - 400 - 480 - 560 - 640 - 720 - 800 - 880 - 960 - 1040 - 1120 - 1200 - 1280 - 1360 - 1440 - 1520 - 1600 - 1680 - 1760 - 1840 - 1920 - 2000 - 2080 - 2160 - 2240 - 2320 - 2400 - 2480 - 2560 - 2640 - 2720 - 2800 - 2880 - 2960 - 3040 - 3120 - 3200 - 3280 - 3360 - 3440 - 3520 - 3600 - 3680 - 3760 - 3840 - 3920 - 4000
	26	160	4000	
	30	160	4000	
	40	160	4000	
	45	320	4000	

Please specify hole pattern separately
 Special lengths or pitches available upon request, please contact the sales department
 The highlighted rail lengths are available from stock (3120 only for TES 20)

Tab. 25

X
R

3 Product dimensions

CEX20 slider for rail TEX 20

CEX20-80 with compact body and wipers

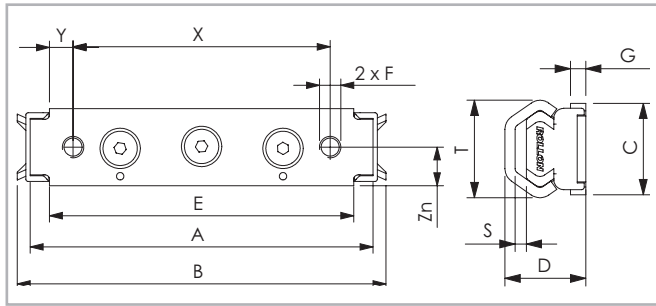

Fig. 32

CEX20-60 with solid body (wipers on request)

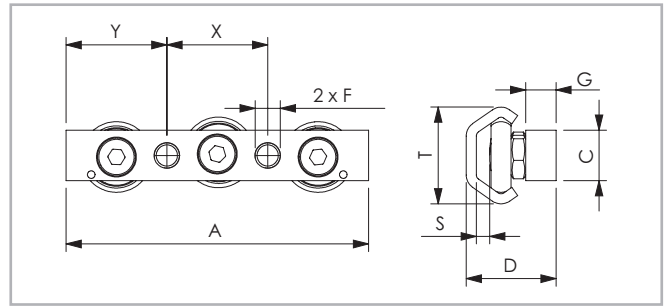

Fig. 33

Slider type	No. of rollers	A [mm]	B [mm]	C [mm]	D [mm]	E [mm]	F	G [mm]	S [mm]	T [mm]	Zn [mm]	X [mm]	Y [mm]	Weight [kg]
CEX20-80	3	80	86	18	15.9	71	M5	5.5	2.2	19.2	9	60	5.5	0.05
CEX20-60		60	-	10	17.8	-	M5	6	2.6	19.2	5	20	20	0.04

Tab. 26

CEX26 slider for rail TEX 26

CEX26-80 with compact body (wipers not available)

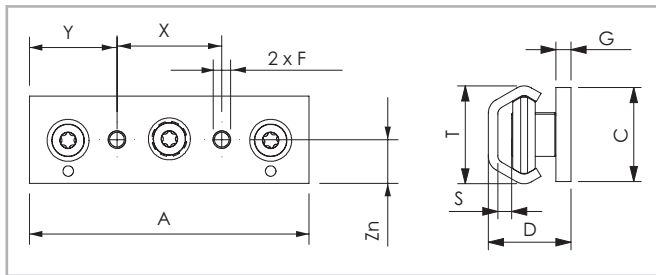

Fig. 34

Slider type	No. of rollers	A [mm]	C [mm]	D [mm]	F	G [mm]	S [mm]	T [mm]	X [mm]	Y [mm]	Zn [mm]	Weight [kg]
CEX26-80	3	80	25	22	M5	4	3.7	26.1	30	25	12.5	0.095

Tab. 27

CEX30 slider for rail TEX 30

CEX30-88 with compact body and wipers

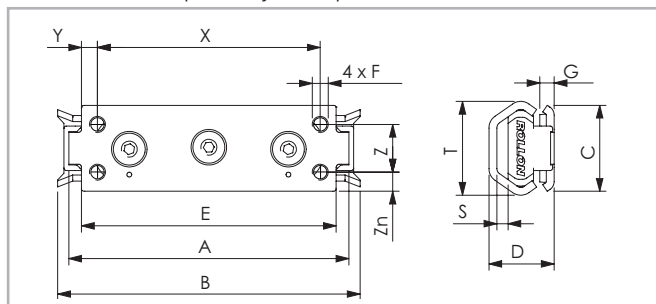

Fig. 35

CEX30-80 with solid body (wipers on request)

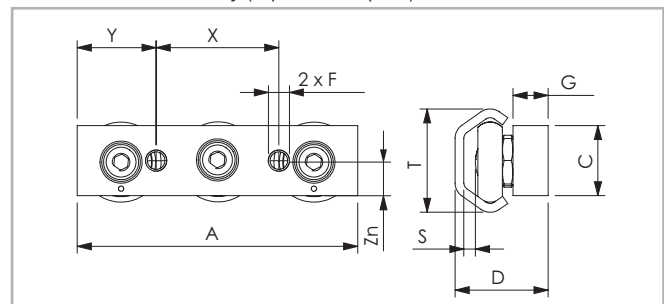

Fig. 36

Slider type	No. of rollers	A [mm]	B [mm]	C [mm]	D [mm]	E [mm]	F	G [mm]	S [mm]	T [mm]	Z [mm]	Zn [mm]	X [mm]	Y [mm]	Weight [kg]
CEX30-88	3	88	95	27	20.5	80	M5	4.5	3.5	29.5	15	6	70	5	0.11
CEX30-80		80	-	20	26.5	-	M6	10	3.3	29.5	-	10	35	22.5	0.17

Tab. 28

CEX40 slider for rail TEX 40

CEX40-135 with compact body (wipers on request)

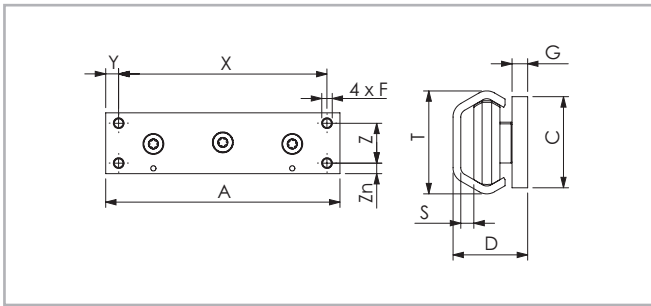

Fig. 37

Slider type	No. of rollers	A [mm]	C [mm]	D [mm]	F	G [mm]	S [mm]	T [mm]	X [mm]	Y [mm]	Z [mm]	Zn [mm]	Weight [kg]
CEX40-135	3	135	35	28.65	M6	6	5	39.5	120	7.5	23	6	0.450

Tab. 29

CEX45 slider for rail TEX 45

CEX45-150 with compact body and wipers

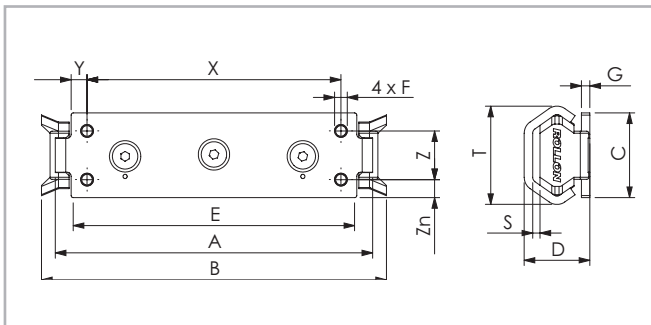

Fig. 38

CEX45-120 with solid body (wipers on request)

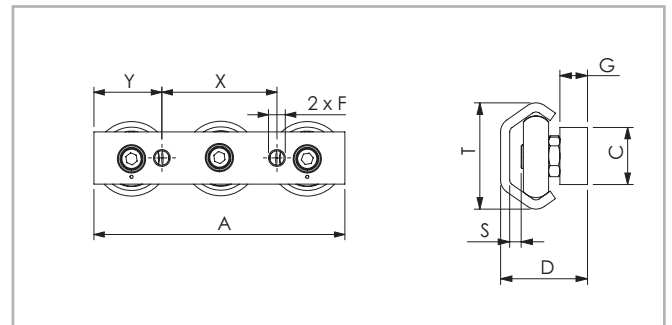

Fig. 39

Slider type	No. of rollers	A [mm]	B [mm]	C [mm]	D [mm]	E [mm]	F	G [mm]	S [mm]	T [mm]	Z [mm]	Zn [mm]	X [mm]	Y [mm]	Weight [kg]
CEX45-150	3	150	160	40	31	135	M6	4	5	46.4	23	8.5	120	7.5	0.40
CEX45-120		120	-	25	38	-	M8	12	5.7	46.4	-	12.5	55	32.5	4.47

Tab. 30

> UEX - Stainless steel guides with flat raceways

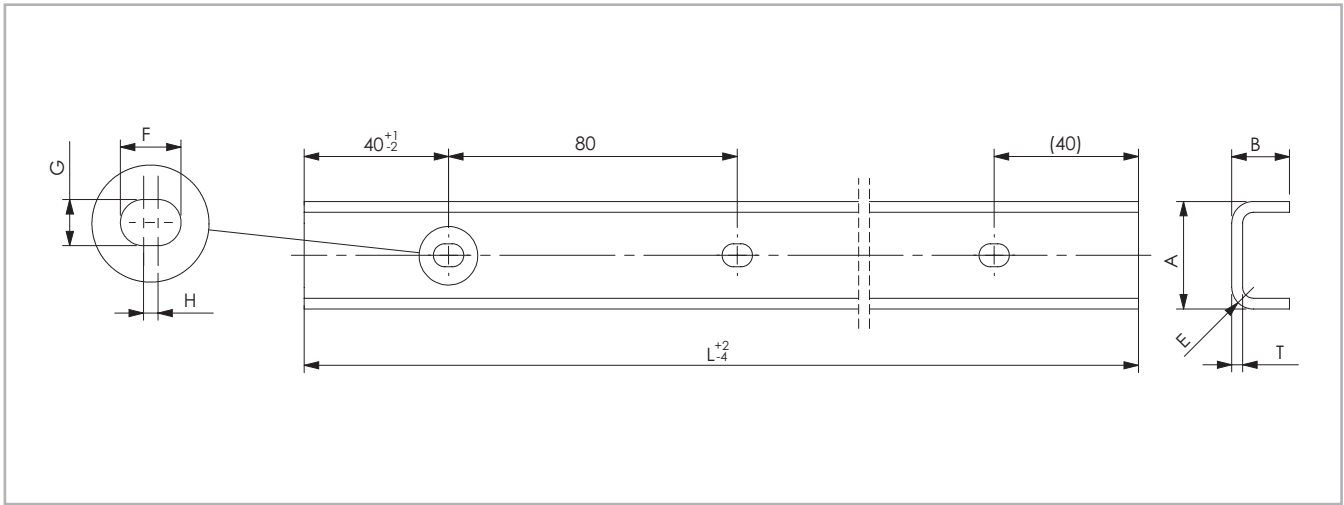

Fig. 40

Rail type	Size	A [mm]	B [mm]	T [mm]	E [mm]	F [mm]	G [mm]	H [mm]	Holes for screws	Weight [kg/m]
UEX	30	29.8	16	3	6	11	6	5	M5	1.39
	40	38.5	21	3	6	13	9	4	M8	1.7
	45	43.8	24.5	4	9	11	9	2	M8	2.79

Tab. 31

Rail type	Size	Min length [mm]	Max length [mm]	Standard length L [mm]
UEX	30	160	4000	160 - 240 - 320 - 400 - 480 - 560 - 640 - 720 - 800 - 880 - 960 - 1040 - 1120 - 1200 - 1280 - 1360 - 1440 - 1520 - 1600 - 1680 - 1760 - 1840 - 1920 - 2000 - 2080 - 2160 - 2240 - 2320 - 2400 - 2480 - 2560 - 2640 - 2720 - 2800 - 2880 - 2960 - 3040 - 3120 - 3200 - 3280 - 3360 - 3440 - 3520 - 3600 - 3680 - 3760 - 3840 - 3920 - 4000
	40	160	4000	
	45	320	4000	

Please specify hole pattern separately
 Special lengths or pitches available upon request, please contact the sales department
 The highlighted rail lengths are available from stock

Tab. 32

CEXU30 slider for rail UEX 30

CEXU30-80 with solid body (wipers on request)

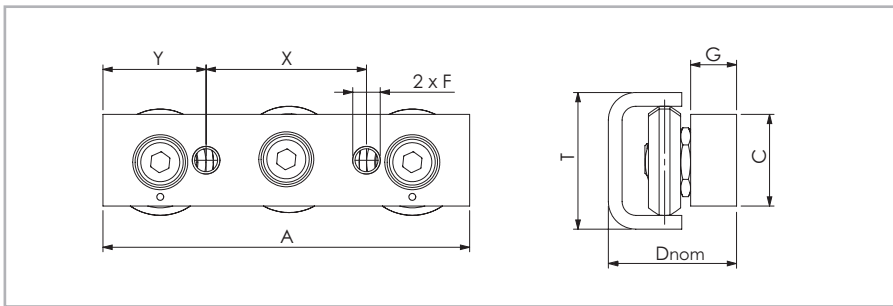

Fig. 41

Slider type	No. of rollers	A [mm]	C [mm]	D _{nom} [mm]	F	G [mm]	T [mm]	X [mm]	Y [mm]	Weight [kg]
CEXU30-80	3	80	20	27.95 ± 0.6	M6	10	31.8	35	22.5	0.16

Tab. 33

CEX40 slider for rail UEX 40

CEX40-135 with compact body (wipers on request)

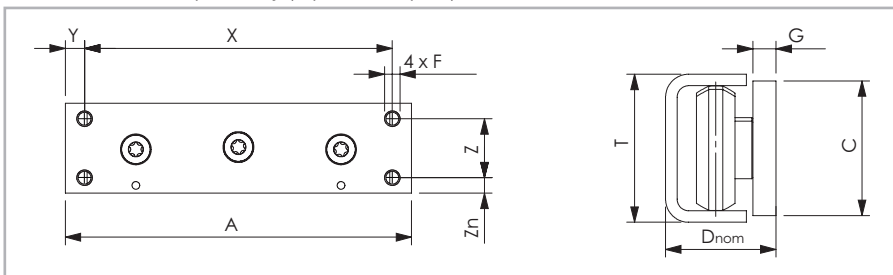

Fig. 42

Slider type	No. of rollers	A [mm]	C [mm]	D _{nom} [mm]	F	G [mm]	T [mm]	Z [mm]	Zn [mm]	X [mm]	Y [mm]	Weight [kg]
CEX40-135	3	135	35	29.95 ± 1.6	M6	6	38.5	23	8	120	7.5	0.45

Tab. 34

CEXU45 slider for rail UEX 45

CEXU45-120 with solid body (wipers on request)

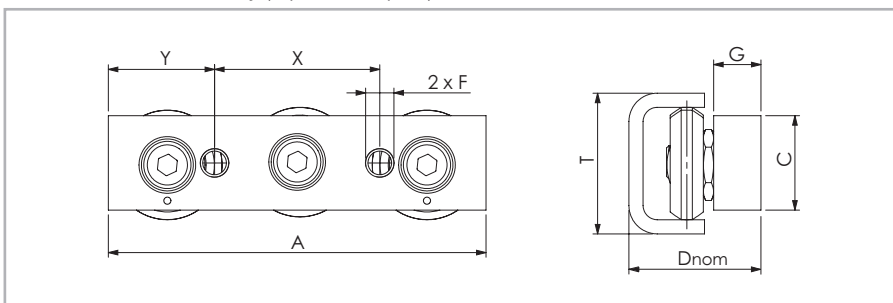

Fig. 43

Slider type	No. of rollers	A [mm]	C [mm]	D _{nom} [mm]	F	G [mm]	T [mm]	X [mm]	Y [mm]	Weight [kg]
CEXU45-120	3	120	25	37.25 ± 1.75	M8	12	44.8	55	32.5	0.45

Tab. 35

Accessories 

> Rollers

RLN / RLA

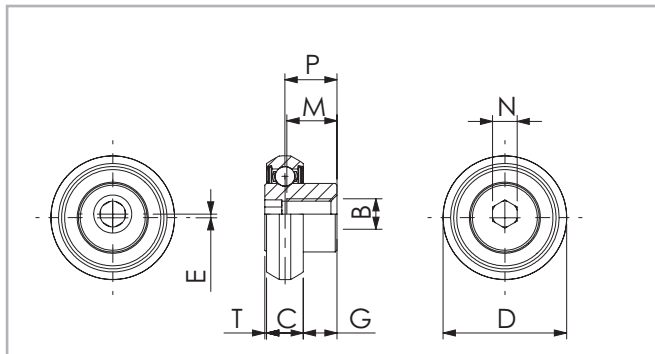

Fig. 44

Roller	Type	For rail	For slider	B [mm]	C [mm]	D [mm]	E [mm]	G [mm]	M [mm]	P [mm]	T [mm]	N Key	C _{Orad} [N]	Weight [Kg]
RLN26	Conc.	TEN 26	CES 26-80	M5	6	20.2	-	5.5	8.2	8.5	0.3	4	560	0.013
RLA26	Ecc.	TES 26	CES 26-80	M5	6	20.2	0.6	5.5	8.2	8.5	0.3	4	560	0.013
RLN40	Conc.	TEN 40	CEN 40-...	M6	10	31.5	-	4.65	9.65	10	-	5	1200	0.048
RLA40	Ecc.	TES 40	CES 40-135	M6	10	31.5	0.7	4.65	9.65	10	-	5	(950*)	0.048

2Z (dust cover seal)
*If used in U-Rail.

Tab. 36

RLNX / RLAX

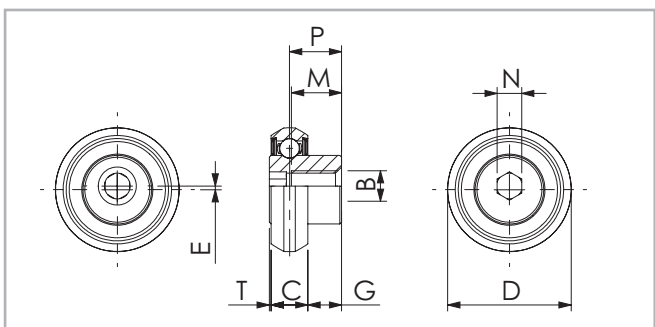

Fig. 45

Roller	Type	For rail	For slider	B [mm]	C [mm]	D [mm]	E [mm]	G [mm]	M [mm]	P [mm]	T [mm]	N Key	C _{Orad} [N]	Weight [Kg]
RLNX26	Conc.	TEX 26	CEX 26-80	M5	6	20.2	-	5.5	8.2	8.5	0.3	4	370	0.013
RLAX26	Ecc.	TEX 26	CEX 26-80	M5	6	20.2	0.6	5.5	8.2	8.5	0.3	4	370	0.013
RLNX40	Conc.	TEX 40	CEX 40-135	M6	10	31.5	-	4.65	9.65	10	-	5	735	0.048
RLAX40	Ecc.	UEX 40	CEX 40-135	M6	10	31.5	0.7	4.65	9.65	10	-	5	(590*)	0.048

2RS (splashproof seal)
*If used in U-Rail.

Tab. 37

CRPN / CRPA

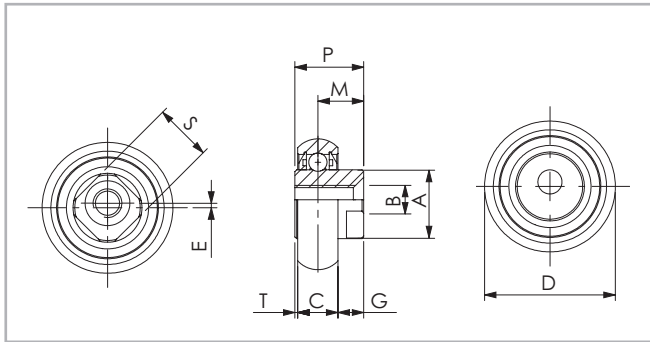

Fig. 46

Roller	Type	For rail	For slider	A [mm]	B [mm]	C [mm]	D [mm]	E [mm]	G [mm]	M [mm]	P [mm]	S [mm]	T [mm]	Key*	C _{brad} [N]	Weight [kg]
CRPN20-2Z	Conc.	TES 20	CES 20-80	8	M4	4	14	-	4	6	8.2	6	0.2	CK20	163	0.006
CRPA20-2Z	Ecc.							0.5								
CRPN30-2Z	Conc.	TES 30	CES 30-88	12	M5	7	22.8	-	4.5	8	12	10	0.5	CK30	435	0.002
CRPA30-2Z	Ecc.							0.8								
CRPN45-2Z	Conc.	TES 45	CES 45-150	16	M6	11	35.6	-	6	11.5	17.3	13	0.3	CK28	870	0.068
CRPA45-2Z	Ecc.							0.8								

2Z (dust cover seal)

* The key must be ordered separately.

Tab. 38

CRPNX / CRPAX

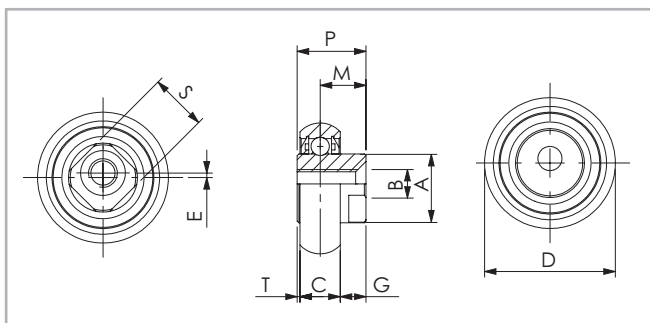

Fig. 47

Roller	Type	For rail	For slider	A [mm]	B [mm]	C [mm]	D [mm]	E [mm]	G [mm]	M [mm]	P [mm]	S [mm]	T [mm]	Key*	C _{brad} [N]	Weight [kg]
CRPNX20-2RS	Conc.	TEX 20	CEX 20-80	8	M4	4	14	-	4	6	8.2	6	0.2	CK20	150	0.006
CRPAX20-2RS	Ecc.							0.5								
CRPNX30-2RS	Conc.	TEX 30	CEX 30-88	12	M5	7	22.8	-	4.5	8	12	10	0.5	CK30	400	0.02
CRPAX30-2RS	Ecc.							0.8								
CRPNX45-2RS	Conc.	TEX 45	CEX 45-150	16	M6	11	35.6	-	6	11.5	17.3	13	0.3	CK28	800	0.068
CRPAX45-2RS	Ecc.							0.8								

2RS (splashproof seal)

* The key must be ordered separately.

Tab. 39

CRN / CRA

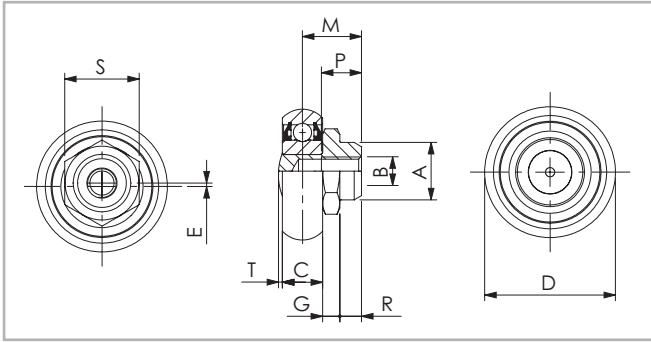

Fig. 48

Roller	Type	For rail	For slider	A [mm]	B [mm]	C [mm]	D [mm]	E [mm]	G [mm]	M [mm]	P [mm]	R [mm]	S [mm]	T [mm]	Key*	C _{Orad} [N]	Weight [kg]
CRN20-2Z	Conc.	TES 20	CES 20-60	6	M4	4	14	-	2.9	6.7	6	1.8	8	0.25	CK18	163	0.006
CRA20-2Z	Ecc.							0.5									
CRN30-2Z	Conc.	TES 30	CES 30-80	10	M5	7	22.8	-	3	10.3	9	3.8	13	0.7	CK28	435	0.002
CRA30-2Z	Ecc.							0.6									
CRN45-2Z	Conc.	TES 45	CES 45-120	12	M6	11	35.6	-	5	15	14.5	4.5	15	1	CK43	870	0.068
CRA45-2Z	Ecc.							0.8									

2Z (dust cover seal)

* The key must be ordered separately.

Tab. 40

CRNX / CRAX

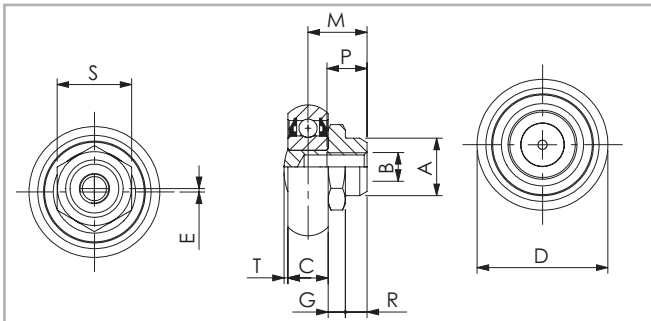

Fig. 49

Roller	Type	For rail	For slider	A [mm]	B [mm]	C [mm]	D [mm]	E [mm]	G [mm]	M [mm]	P [mm]	R [mm]	S [mm]	T [mm]	Key*	C _{Orad} [N]	Weight [kg]
CRNX20-2RS	Conc.	TEX 20	CEX 20-60	6	M4	4	14	-	2.9	6.7	6	1.8	8	0.25	CK18	150	0.006
CRAX20-2RS	Ecc.							0.4									
CRNX30-2RS	Conc.	TEX 30	CEX 30-80	10	M5	7	22.8	-	3	10.3	9	3.8	13	0.7	CK28	400	0.022
CRAX30-2RS	Ecc.							0.6									
CRNX45-2RS	Conc.	TEX 45	CEX 45-120	12	M6	11	35.6	-	5	15	14.5	4.5	15	1	CK43	800	0.07
CRAX45-2RS	Ecc.							0.8									

2RS (splashproof seal)

* The key must be ordered separately.

Tab. 41

CPN / CPA

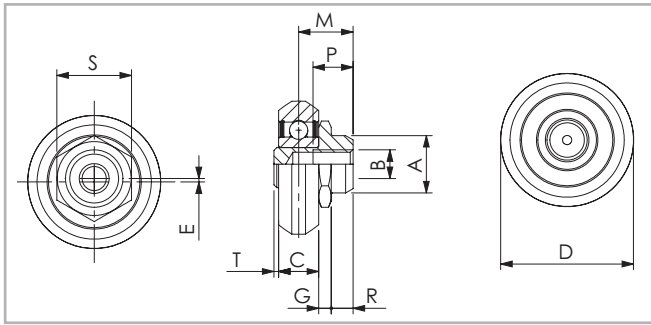

Fig. 50

Roller	Type	For rail	For slider	A [mm]	B [mm]	C [mm]	D [mm]	E [mm]	G [mm]	M [mm]	P [mm]	R [mm]	S [mm]	T [mm]	Key*	C _{Orad} [N]	Weight [kg]
CPN30-2Z	Conc.	UES 30	CESU 30-80	10	M5	7	23.2	-	2.2	9.5	7	3.8	13	0.7	CK28	435	0.018
CPA30-2Z	Ecc.							0.6									
CPN45-2Z	Conc.	UES 45	CESU 45-120	12	M6	11	35	-	2.5	12.5	12	4.5	15	0.9	CK43	870	0.06
CPA45-2Z	Ecc.							0.8									

2Z (dust cover seal)

* The key must be ordered separately.

Tab. 42

CPNX / CPAX

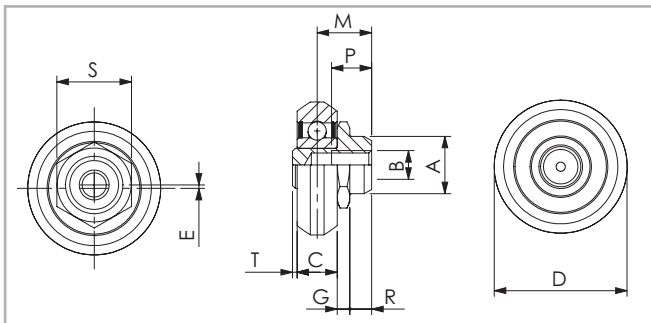

Fig. 51

Roller	Type	For rail	For slider	A [mm]	B [mm]	C [mm]	D [mm]	E [mm]	G [mm]	M [mm]	P [mm]	R [mm]	S [mm]	T [mm]	Key*	C _{Orad} [N]	Weight [kg]
CPNX30-2RS	Conc.	UEX 30	CEXU 30-80	10	M5	7	23.2	-	2.2	9.5	7	3.8	13	0.7	CK28	400	0.018
CPAX30-2RS	Ecc.							0.6									
CPNX45-2RS	Conc.	UEX 45	CEXU 45-120	12	M6	11	35	-	2.5	12.5	12	4.5	15	0.9	CK43	800	0.06
CPAX45-2RS	Ecc.							0.8									

2RS (splashproof seal)

* The key must be ordered separately.

Tab. 43

CPN...Z / CPA...Z

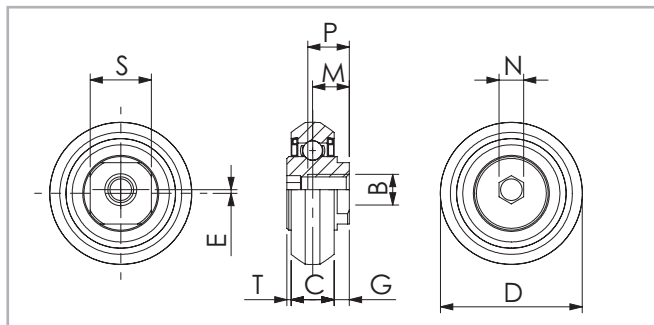

Fig. 52

Roller	Type	For rail	For slider	B [mm]	C [mm]	D [mm]	E [mm]	G [mm]	M [mm]	P [mm]	S [mm]	T [mm]	Key*	C _{Grad} [N]	Weight [kg]
CPN30Z-55	Conc.	TEP 30	CEP 30-...	M5	7	23.2	-	2.5	6	6.8	10	0.3	CK30	600	0.020
CPA30Z-55	Ecc.	UEP 30					0.6						4		

2RS (splashproof seal)

* The CK30 key must be ordered separately.

Tab. 44

> Wipers

For wipers indicated as „on request“ from pag. XR-10 to XR-19 please contact our Technical Department.

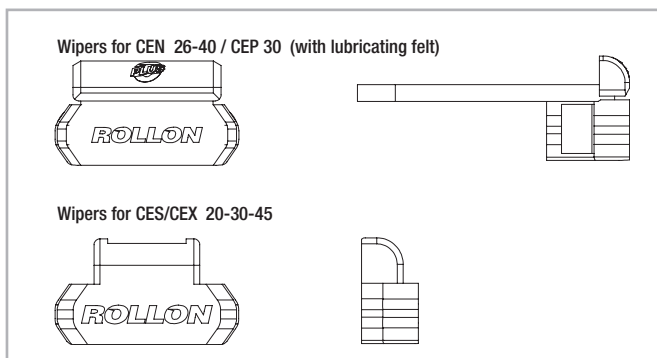

Fig. 53

Slider type	Ordering code (for a pair of wipers)
CEN26-...	ZK-WCEN26
CEP30-...	ZK-WCEP30
CEN40-...	ZK-WCEN40
CES20-80 - CEX20-80	ZK-WCES20
CES30-88 - CEX30-88	ZK-WCES30
CES45-150 - CEX45-150	ZK-WCES45

Tab. 45

> Fixing screws

We recommend fixing screws according to ISO 7380 with low head height or TORX® screws (see fig. 54) on request.

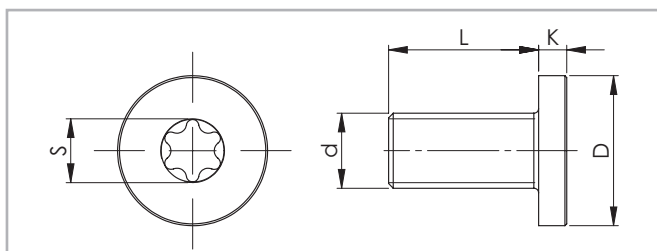

Fig. 54

Rail size	Screw type	d	D [mm]	L [mm]	K [mm]	S	Tightening torque [Nm]
20	M4 x 8	M4 x 0.7	8	8	2	T20	3
26	M5 x 10	M5 x 0.8	10	10	2	T25	9
30	M5 x 10	M5 x 0.8	10	10	2	T25	9
40	M8 x 16	M8 x 1.25	16	16	3	T40	20
45	M8 x 16	M8 x 1.25	16	16	3	T40	22

Technical instructions



> Lubrication

All sliders CEN/CEP are supplied with high quality thermoplastic elastomer wipers with optimized lips and a synthetic felt soaked in lubricating oil, which releases a thin lubricating film on the raceways and ensures proper operation. The period of self-lubrication depends on the conditions of use and the level of environmental cleanliness. In normal conditions, the self-lubricating wipers can last up to 1000 km, then they need to be replaced with a new pair. New wipers can be ordered from Rollon using the codes shown on pag. XR-24. To replace them, simply extract the old ones and insert the new ones frontally. The rollers are lubricated for life with grease lithium soaps and feature 2Z lateral seals.

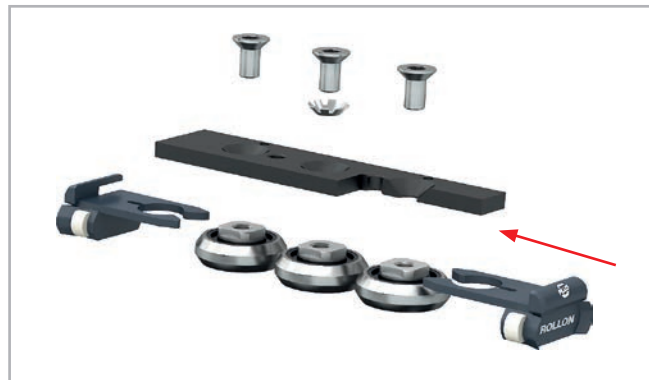

Fig. 55

Other sliders can be supplied with wipers in high quality thermoplastic elastomer, without lubricating felt. Please check the availabilities from pag. XR-10 to XR-19, and contact our Technical Department for wipers indicated as „on request“. In this case it is advisable to lubricate the raceways with specific bearing grease. The interval between lubrication treatments depends mainly on environmental conditions, bearing speed and temperature. Under normal conditions, it is advisable to lubricate locally after 100 km of use or after six months of service. In case of critical applications, lubrication treatments should be more frequent. Before lubricating, remember to clean the raceway surfaces carefully. We advise using a lithium grease of medium consistency for rolling-element bearings. The rollers are lubricated for life with grease lithium soaps and feature 2RS or 2Z lateral seals.



Fig. 56

Different lubricants are available on request for special applications:

- FDA-approved lubricant for use in the food industry
- specific lubricant for clean rooms
- specific lubricant for the marine technology sector
- specific lubricant for high and low temperatures

For specific information, contact Rollon technical support.

Under normal conditions, correct lubrication:

- reduces friction
- reduces wear
- reduces stress on contact surfaces due to elastic deformation
- reduces noise during operation
- increases the regularity of the rolling movement

> T+U-System

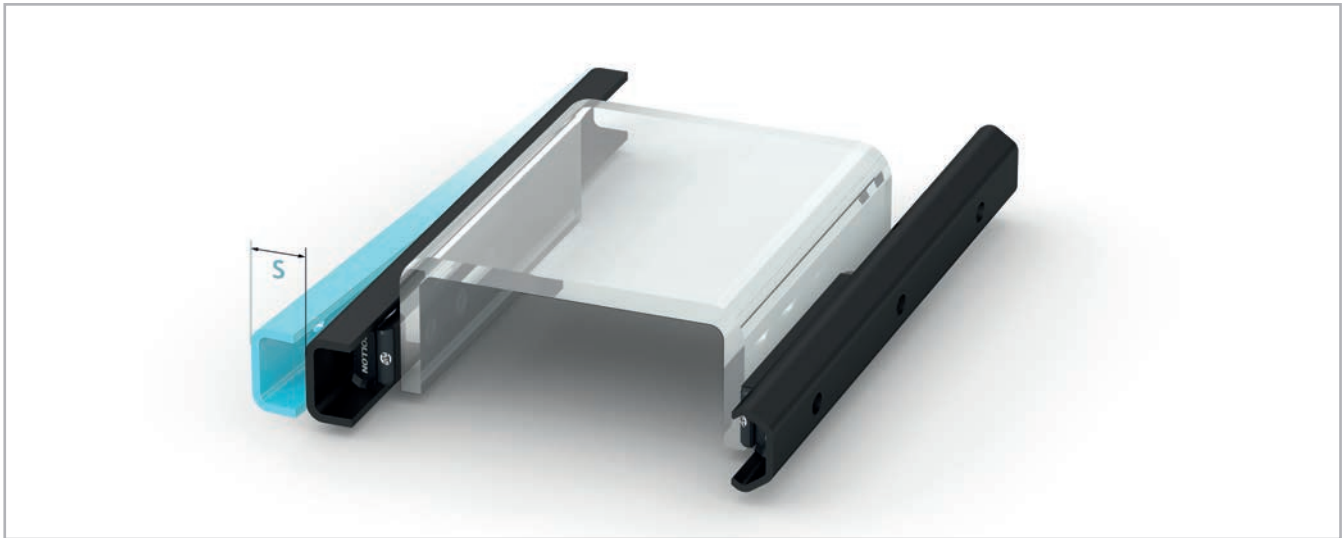

Fig. 57

Solves axial deviations in parallelism

Mounting two linear bearing rails in a parallel manner is always important but rarely easy. Distortions in axial alignment can drastically reduce the life of the rails. These distortions can bind and overload sliders. Combining shaped and flat raceways it is possible to compensate axial deviation in parallelism of the mounting surfaces without additional modifications of those surfaces. T+U rails easily address these alignment issues to create an economical parallel rail system.

In a T+U-System, the slider in the T rail carries axial and radial loads and guides the movement of the U, which has lateral freedom.

U rails have flat parallel raceways that allow free lateral movement of the sliders. The maximum freedom a slider in the U rail can offer can be calculated using the values S_1 and S_2 (see fig. 58, tab. 47 and the formula in fig. 59). With nominal value B_{nom} as the starting point, S_1 indicates the maximum allowed movement into the rail, while S_2 represents the maximum offset towards the outside of the rail.

If the length of the guide rail is known, the maximum allowable angle deviation of the mounting surface (fig. 60 and tab. 48) can be calculated. In this case the slider in the U rail has the freedom to travel from the innermost position S_1 to the outermost position S_2 .

Maximum offset

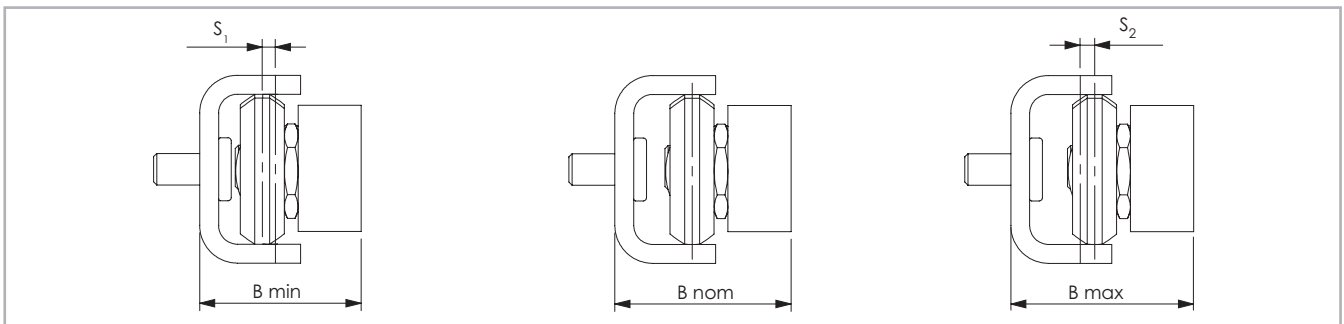

Fig. 58

Slider type	S_1 [mm]	S_2 [mm]	B_{min} [mm]	B_{nom} [mm]	B_{max} [mm]
CESU30 / CEXU30	0.6	0.6	27.35	27.95	28.55
CEP30	0.6	0.6	20.5	21.1	21.7
CEN40 / CES40 / CEX40	1.6	1.6	28.35	29.95	31.55
CESU45 / CEXU45	1.75	1.75	35.50	37.25	39

Tab. 47

Guideline for the maximum angle deviation α , achievable with the longest guide rail

$\alpha = \arctan \frac{S^*}{L}$	$S^* = \text{sum of } S_1 \text{ and } S_2$ $L = \text{length of the rail}$
----------------------------------	--

Fig. 59

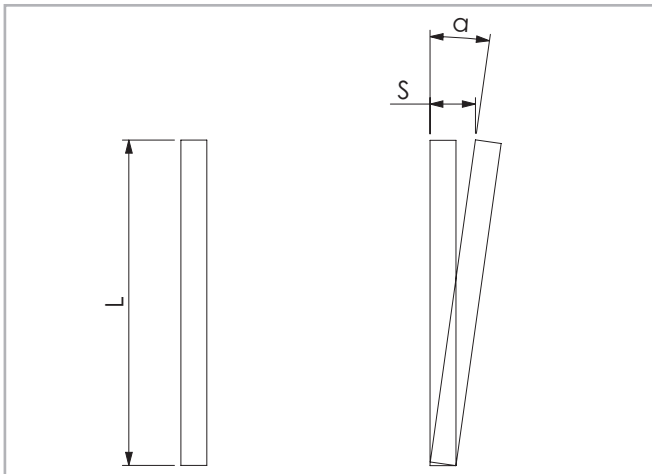

Fig. 60

Size	Rail length [mm]	Offset S* [mm]	Angle α [°]
30	4000	2	0.028
40	4000	3.4	0.048
45	4000	3.5	0.050

Tab. 48

X
R

> **Service life calculation for N/P-series**

The calculation of service life can be done only for rails with nitrided raceways, for which the dynamic load capacity C is given. The dynamic load capacity C is a conventional variable that corresponds to a nominal

service life of 100 km. For values of the individual slider see pg. XR-5. The following formula (see fig. 61) links the calculated theoretical service life to the dynamic load capacity and the equivalent load:

$$L_{km} = 100km \cdot \left(\frac{C}{P} \cdot \frac{f_c}{f_i} \cdot f_h \right)^3$$

L_{km} = theoretical service life (km)
 C = dynamic load capacity (N)
 P = effective equivalent load (N)
 f_c = contact factor
 f_i = application coefficient
 f_h = stroke factor

Fig. 61

The equivalent load P corresponds in its effects to the sum of the forces working simultaneously on a slider. If these different load components are known, P results as follows:

$$P = P_r + \left(\frac{P_a}{C_{0ax}} \right) \cdot C_{0rad}$$

Fig. 62

Here the external loads are assumed as constant in time. Brief loads, which do not exceed the maximum load capacities, do not have any relevant effect on the service life and can therefore be neglected.

The contact factor f_c refers to applications in which several sliders pass the same rail section. If two or more sliders move over the same point of a rail, the contact factor according to table 49 to be taken into account in the formula for calculation of the service life.

Number of sliders	1	2	3	4
f_c	1	0.8	0.7	0.63

Tab. 49

The application coefficient f_i takes into account the operational conditions in the service life calculation. It is calculated as described in the following table:

f_i	
Neither shocks nor vibrations, smooth and low-frequency direction change; clean operating conditions; low speeds (<1 m/s)	1 - 1.5
Slight vibrations, average speeds (1 - 1.5 m/s) and average frequency of direction change	1.5 - 2
Shocks and vibrations, high speeds (> 1.5 m/s) and high-frequency direction change; extreme dirt contamination	2 - 3.5

Tab. 50

The stroke factor f_h takes into account the higher load of the raceways and rollers during short strokes on the same total length of run. The corresponding values are taken from the following graph (for strokes longer than 1 m, $f_h = 1$):

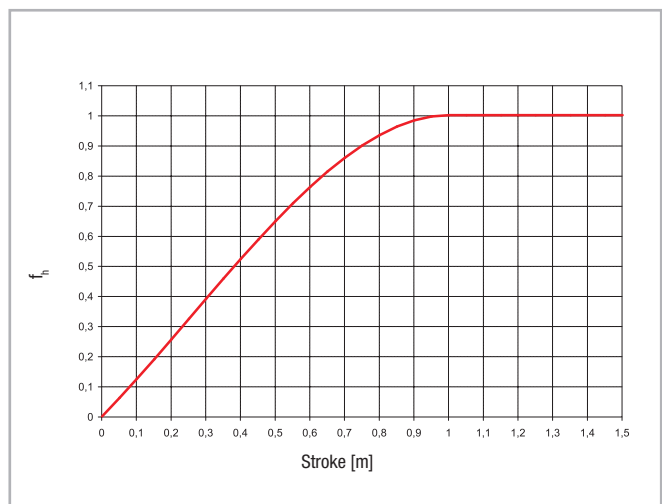

Fig. 63

> **Static load**

The radial load capacity rating, C_{Orad} , the axial load capacity rating C_{Oax} , indicate the maximum permissible values of the load (see pg. XR-5), higher loads will have a detrimental effect on the running quality. A safety factor, S_0 , is used to check the static load, which takes into account the basic parameters of the application and is defined more in detail in the following table:

Safety factor S_0

No shock nor vibration, smooth and low-frequency reverse, high assembly accuracy, no elastic deformations	1 - 1.5
Normal installation conditions	1.5 - 2
Shock and vibration, high-frequency reverse, significant elastic deformation	2 - 3.5

Fig. 64

The ratio of the actual load to maximum permissible load may be as large as the reciprocal of the accepted safety factor, S_0 , at the most.

$$\frac{P_{Orad}}{C_{Orad}} \leq \frac{1}{S_0} \quad \frac{P_{Oax}}{C_{Oax}} \leq \frac{1}{S_0}$$

Fig. 65

The above formulas are valid for a single load case.

If two or more forces are acting simultaneously, please check the following formula:

$$\frac{P_{Orad}}{C_{Orad}} + \frac{P_{Oax}}{C_{Oax}} \leq \frac{1}{S_0}$$

P_{Orad} = effective radial load (N)
 C_{Orad} = permissible radial load (N)
 P_{Oax} = effective axial load (N)
 C_{Oax} = permissible axial load (N)

Fig. 66

The safety factor S_0 can lie on the lower given limit if the occurring forces can be determined with sufficient precision. If shock and vibration are present, the higher value should be selected. For dynamic applications higher safety is required. Please contact Rollon technical support.

> Adjusting the slider

If requested in the order, rails and sliders are delivered as a system with factory adjustment. If rails and sliders are supplied separately or if the slider is to be mounted in another rail, the bearings will need to be adjusted. The suitable approach is the hexagonal spanner for sliders size 26, 40 and the flat spanner for sliders size 20,30,45. CEP30 slider can be adjusted in both ways.

Common preliminary operations:

- (1) Check that the raceways are clean and remove the wipers, to increase sensitivity for proper preload.
- (2) Place the slider in the rail. It may be necessary to align the bearings to be adjusted with the fixed ones to facilitate insertion, since excessive offset may make insertion difficult. Use a flat or hexagonal spanner.
- (3) Use a medium threadlocking adhesive in the screws.
- (4) Lightly tighten the upper bearing screw without over-tightening. Vice versa if the screw has already been previously tightened, loosen it slightly. The bearing must be able to rotate but should not be completely free. Only adjust the eccentric bearings (without the center marked).

With flat spanner

- (5) For the U-rails there must be a thin support (e.g. set key) under the ends of the slider body to ensure the horizontal alignment of the slider in the rail raceways.
- (6) The adjustment can take place at any point on the rail. If possible, position the slider at one end of the rail to simplify insertion of the flat spanner.
- (7) Insert the flat spanner supplied to the side and use it to engage the hexagonal or square shaft of the eccentric pin to be adjusted (see fig. 67).
- (8) Turn the flat adjustment spanner clockwise so that the eccentric bearing contacts the raceway opposite the factory-set fixed bearings, thus reducing the slider clearance to zero. Avoid applying a too high preload, which would cause high wear and reduce service life.
- (9) While holding the pin in the correct position with the flat adjustment spanner, tighten the fixing screw to ensure that the pin is locked in position.
- (10) Run the slider and check the preload over the entire length of the rail. The movement must be smooth. If any oscillation/clearance or excessive force is observed, repeat the adjustment operation. Preload is optimized when the slider runs smoothly and without play.
- (11) Preload values can be checked by slowly inserting the slider at the end of the rails. The insertion force is proportional to the preload. Preload is optimized when the slider runs smoothly and without play.
- (12) For sliders with more than 3 bearings, repeat this procedure for each one to be adjusted. Ensure that all bearings have uniform contact with the raceways.
- (13) While maintaining the angular position of the pin with the flat spanner, tighten the adjusted bearing fixing screw with a torque spanner. The prescribed tightening torque is shown in table 51.
- (14) Reinstall the wipers.

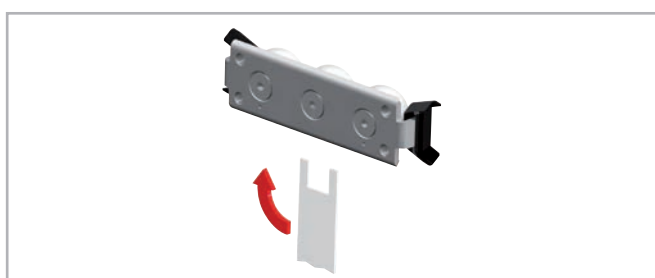

Fig. 67

With hexagonal spanner

- (5) Lock the rail on a stable support so that your hands are free.
- (6) Insert the hexagonal spanner into the eccentric pin, passing it through one of the fixing holes in the rail.
- (7) Turn the hexagonal key slightly so that the eccentric bearings contacts the raceway opposite the factory-set fixed bearings, thus reducing the slider clearance to zero. When turning, support the upper screw by turning in the same direction with a second hexagonal spanner to prevent loosening or changes in preload settings.
- (8) While firmly holding the hexagonal spanner inserted in the eccentric bearing with one hand, use the other hexagonal spanner to turn and tighten the upper screw of the pin. Do not lock or unlock the eccentric bearing by rotating the pin: always turn the top screw.
- (9) Run the slider and check the preload over the entire length of the rail. The movement must be smooth. If any oscillation/clearance or excessive force is observed, repeat the adjustment operation. Preload is optimized when the slider runs smoothly and without play.
- (10) Preload values can be checked by slowly inserting the slider at the end of the rails. The insertion force is proportional to the preload. Preload is optimized when the slider runs smoothly and without play.
- (11) For sliders with more than 3 bearings, repeat this procedure for each one to be adjusted. Ensure that all bearings have uniform contact with the raceways.
- (11) Tighten the pin/screw definitively using a torque spanner to ensure the correct tightening torque, in accordance with the values in table 51, while holding the hexagonal spanner to the pin, to avoid variations in the preload parameters. Always turn the top screw to lock or loosen the bearing.
- (12) Reinstall the wipers.



Fig. 68

Size	Tightening torque [Nm]
20	3
26	7
30	7
40	10
45	12

Tab. 51

> Use of radial ball bearing rollers

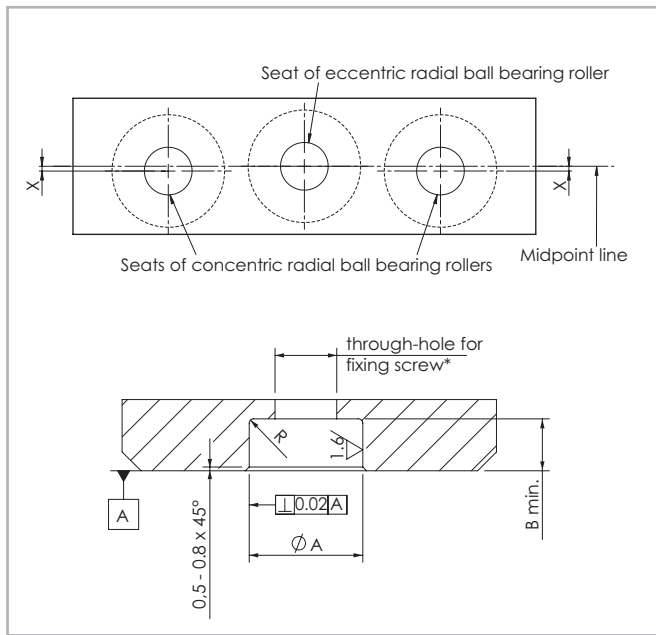

Fig. 69

Slider size	X [mm]	Ø A [mm]	B min. [mm]	Radius R [mm]
20	0.60	6 +0.01/+0.03	2.1	0.5
26	0.40	-	-	-
30 (CES.../CEX...)	0.63	10 +0.01/+0.03	4.1	0.5
30 (CEP...)	0.40	-	-	-
40	0.90	-	-	-
45	0.60	12 +0.01/+0.03	5	1

Tab. 52

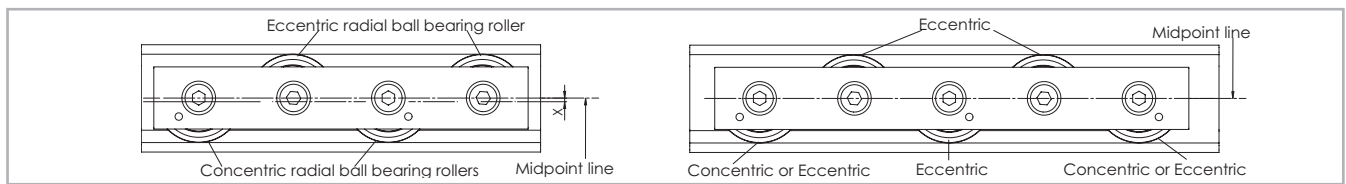

Fig. 70

If purchasing "Radial ball bearing rollers" to install on your own structure (see from p. XR-20 to XR-24) we advise:

- Using a maximum of 2 concentric radial ball bearing rollers
- Offset the seats of the concentric radial ball bearing rollers with respect to those of the eccentric radial ball bearing rollers according to the table (tab. 52).
- To install rollers type CPN/CPA, CPNX/CPAX, CRN/CRA, CRNX/CRAX it is necessary to make a slot in the structure according to the dimensions shown on Fig. 69.

> Anticorrosion treatments

N/P-series

Treatment	Characteristics
Rollon-Nox	Patented high depth nitride hardening and black oxidation treatment that provides good durability under high loads or frequencies and good corrosion resistance. It is standard for all sizes.

Tab. 53

S-series

Treatment	Characteristics
Zinc Plating ISO 2081	Ideal for outdoor applications. Telescopic rails with this treatment are supplied with stainless steel rollers to further increase the corrosion resistance.
Rollon E-coating (K)	As zinc-plated version with additional electro painting that provides a fine black finishing to the entire rail. It can be partially removed from the raceways on the running contact point of the rollers after a period of use. Rails with Rollon E-Coating are supplied with stainless steel rollers to further increase the corrosion resistance.

Tab. 54

X-series

As standard, rails are made of in AISI316L with rollers in hardened AISI440.

Treatment	Characteristics
Electro-polish (X)	Rails are completely electro-polished for further improved corrosion resistance. The electro-polishing treatment also gives the product a very shiny surface.

Tab. 55

Ordering key 

> Rail / slider system

TEX-	960	/1/	CEX20-60	-2RS	X	
						Surface treatments (if different from standard) <i>see pg X-33</i>
				Roller seal		<i>see pg. XR-4 Performance characteristics</i>
				Slider type		<i>see pg. XR-7, XR-9, XR-11 and 12, XR-14, XR-16 and 17, XR-19</i>
				Number of sliders in one rail		
	Rail length in mm <i>see pg. XR-6, XR-8, XR-10, XR-13, XR-15, XR-18</i>					
Rail type <i>see pg. XR-6, XR-8, XR-10, XR-13, XR-15, XR-18</i>						

Ordering example: TEX-00960/1/CEX20-060-2RS

Hole pitch: 40-11 x 80-40

Notes on ordering: The rail length codes are always 5 digits, the slider length codes are always 3 digits; use zeroes as a prefix when lengths are shorter

> Rail

TEX-	30-	960	X	
				Surface treatments (if different from standard) <i>see pg X-33</i>
		Rail length in mm <i>see pg. XR-6, XR-8, XR-10, XR-13, XR-15, XR-18</i>		
	Size <i>see pg. XR-6, XR-8, XR-10, XR-13, XR-15, XR-18</i>			
Rail type <i>see pg. XR-6, XR-8, XR-10, XR-13, XR-15, XR-18</i>				

Ordering example: TEX-30-00960

Hole pattern: 40-11 x 80-40

Notes on ordering: The rail length codes are always 5 digits; use zeroes as a prefix when lengths are shorter

> Slider

CES30-80	-2Z	K	
			Surface treatments (if different from standard) <i>see pg X-33</i>
	Roller seal <i>see pg. XR-4 Performance characteristics</i>		
Slider type <i>see pg. XR-7, XR-9, XR-11 and 12, XR-14, XR-16 and 17, XR-19</i>			

Ordering example: CES30-080-2Z

Notes on ordering: The slider length codes are always 3 digits; use zeroes as a prefix when lengths are shorter

> Accessories

Roller pins

CRPAX	45	-2RS	
		Roller seal	see pg. XR-20 to XR-24
	Size	see pg. XR-20 to XR-24	
Roller type	see pg. XR-20 to XR-24		

Ordering example: CRPAX45-2RS

CK	30	
	Size	see pg. XR-20 to XR-24

Fixing screws

Rail type	Size	Ordering description
TEN/TEP UEN/UEP	26	TORX® screw TC 28 M5x10
	30	TORX® screw TC 28 M5x10
	40	TORX® screw TC 43 M8x16
TES / UES	20	TORX® screw TC 18 M4x8
	26	TORX® screw TC 28 M5x10
	30	TORX® screw TC 28 M5x10
	40	TORX® screw TC 43 M8x16
TEX / UEX	45	TORX® screw TC 43 M8x16
	26	TORX® screw TC 28 M5x10 NIC
	30	TORX® screw TC 28 M5x10 NIC
	40	TORX® screw TC 43 M8x16 NIC
	45	TORX® screw TC 43 M8x16 NIC

see pg. XR-24, fig. 54, tab. 46