

**ROLLON**<sup>®</sup>  
BY TIMKEN

*Prismatic Rail*

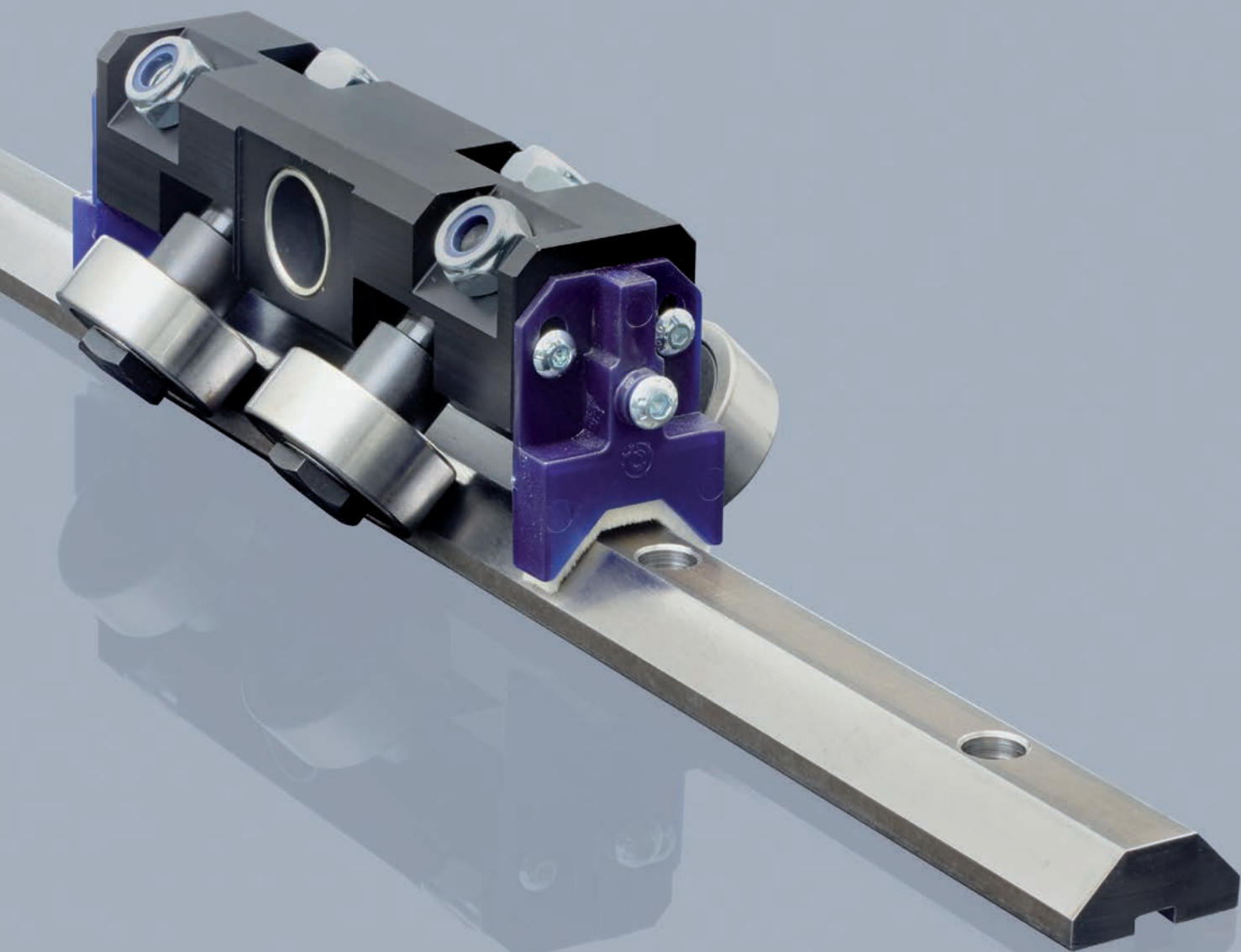

## Product explanation



### > Prismatic Rail: with cylindrical or V-shaped rollers



Fig. 1

The Prismatic Rail product family is composed of roller sliders sliding on V-shaped rails made of hardened steel. These linear guides also have high self-alignment properties.

V-shaped rails are induction hardened and polished, available in three sizes: 28, 35 and 55 mm. Rails can be machined with two straight cuts, one straight and one slanting cut or two slanting cuts. These options allow to create joinable versions, and thus obtaining longer strokes.

The aluminium slider can be configured with a variable number of rollers with steel pins, ranging from 3 to 6. Rollers are in turn available in two variants, cylindrical or V-shaped, with variable diameter from  $\varnothing 30$  a  $\varnothing 62$  depending on rail size.

#### The most important characteristics:

- Long life thanks to hardened raceways
- Optimal reliability in dirty environments
- Self-aligning system
- Simple mounting
- High dynamics

#### Preferred areas of application:

- Robot and handling systems
- Industrial automation
- Logistics
- Packaging machines

**Drilled guide rails with straight cut:**

Machining provided for guide rails with no joint.

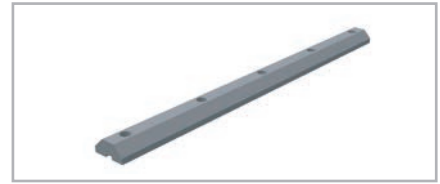

Fig. 2

**Drilled guide rails with one straight and one slanting cut:**

Machining provided for the crop down sizes of guide rail ends with joints.



Fig. 3

**Drilled guide rails with 2 slanting cuts:**

Machining provided for the intermediate crop down sizes of guide rail ends with multiple joints.



Fig. 4

**Sliders with rollers Ø30 - Ø40:**

Floating and fixed sliders with rollers Ø30 (guide size 28) and Ø40 (guide size 35).



Fig. 5

**Sliders with rollers Ø52- Ø62:**

Floating and fixed sliders with rollers Ø52 and Ø62 (guide size 55).

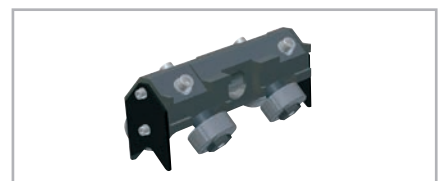

Fig. 6

**Assembly pins:**

Steel pins.



Fig. 7

## Technical data

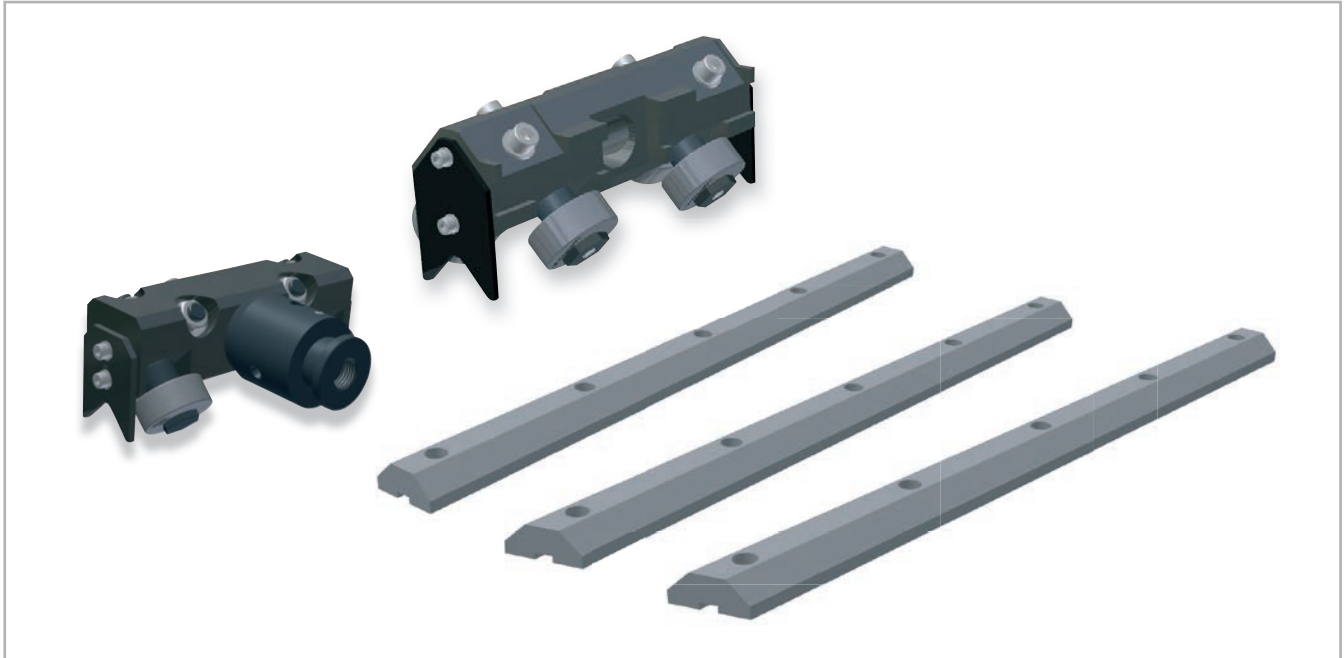

Fig. 8

### Performance characteristics:

- Sizes available: 28,35 and 55 mm.
- Rollers dimensions: Ø30 - Ø40 - Ø52 - Ø62.
- V-shaped rollers in hardened C45 steel available for sizes 28 and 35.
- Aluminum sliders, floating and fixed, with 3, 4 or 6 rollers.
- Max. speed: 7 m/s (depending on application).
- Max. acceleration: 20 m/s<sup>2</sup> (depending on application).
- Max. radial load capacity: 15000 (per slider).
- Max. axial load capacity: 15000 (per slider).
- Operating temperature: from -10°C to +80°C.
- Induction hardened and polished rails.
- Max. rail length: 4100 mm.
- Steel assembly pins.

### Notes:

- Longer stroke achievable with joinable versions.
- V-shaped rails available in drilled or non-drilled versions.
- Please follow the diagrams in every slider section to ensure correct assembly.
- For applications with high projecting loads, the sliders' rollers must be adjusted so that the load is supported by the maximum possible number of them.

# Product dimensions

## > Steel V-shaped rails

Material: high-performance alloy steel: R > 900 MPa  
 Hardened and tempered: core hardness 240 HB.

Induction-hardened and polished. Track hardness > 58 HRC

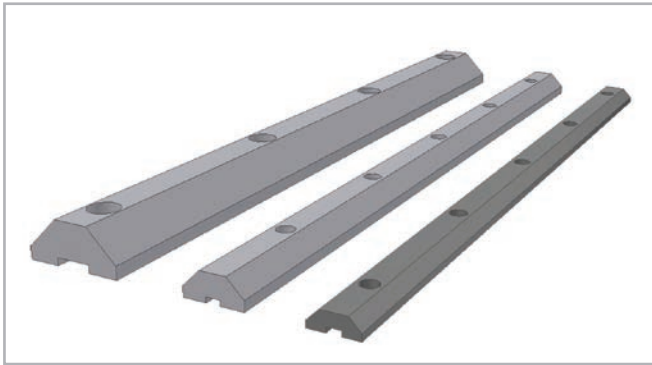

Fig. 9

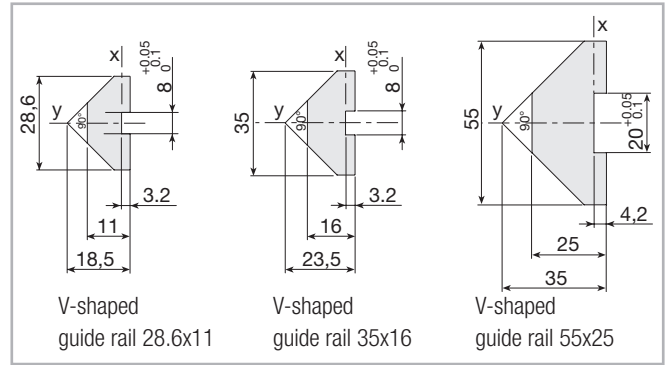

Fig. 10

Features	Moment of inertia Ix [mm <sup>4</sup> ]	Moment of inertia Iy [mm <sup>4</sup> ]	Weight [Kg/m]
28.6x11	2148	14490	2
35x16	7932	36405	3.5
55x25	41906	194636	7.8

Tab. 1

## > Machining: drilled guide rails with straight cut

P\_ \_ -.....F V-shaped guide rails, length L, drilled

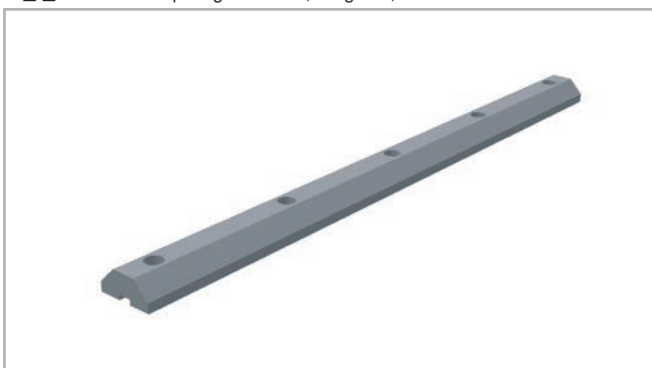

Fig. 11

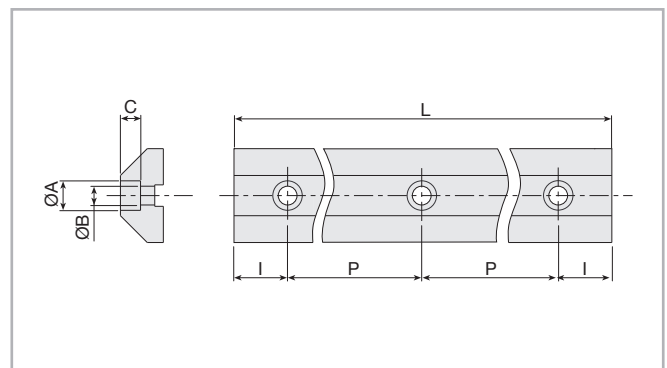

Fig. 12

Size	Treatment	L. max [mm]	P [mm]	I [mm]	A [mm]	B [mm]	C [mm]	Code
28.6x11	Induction-hardened	3980	150	40	11	7	5	P28...
35x16	Induction-hardened	4100	100	50	11	7	7.5	P35...
55x25	Induction-hardened	4100	150	25	18	11	11.5	P55...

Tab. 2

P  
R

> Machining: drilled guide rails with 1 straight and 1 slanting cut

P\_\_ -.....FX V-shaped guide rails with 1 slanting cut, length L, drilled



Fig. 13

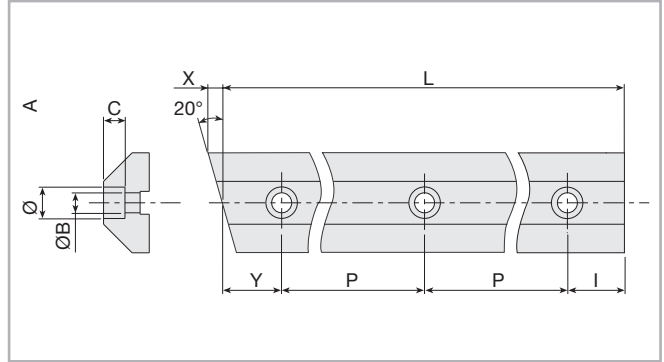

Fig. 14

Size	Treatment	L. max [mm]	P [mm]	Y [mm]	I [mm]	A [mm]	B [mm]	C [mm]	Code
28.6x11	Induction-hardened	3700	150	50	50	11	7	5	P28...
35x16	Induction-hardened	4000	100	50	50	11	7	7.5	P35...
55x25	Induction-hardened	3950	150	25	25	18	11	11.5	P55...

Tab. 3

> Machining: drilled guide rails with 2 slanting cuts

P\_\_ -.....FXX V-shaped guide rails with 2 slanting cuts, length L, drilled



Fig. 15

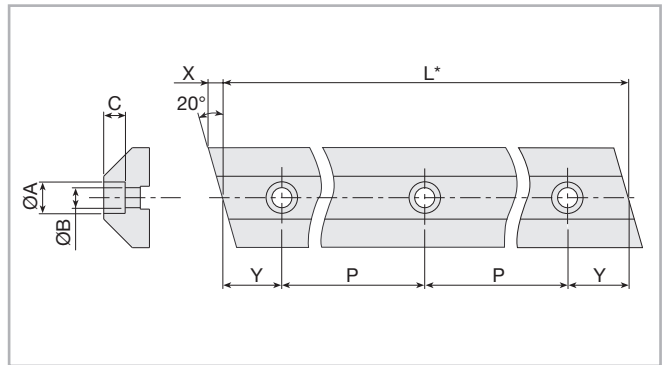

Fig. 16

\*in order to maintain a constant hole pitch, arrange the guide rails so that the length "L" is equal to:  $n \cdot P + 2 \cdot Y$

Size	Treatment	L. max [mm]	P [mm]	Y [mm]	A [mm]	B [mm]	C [mm]	Code
28.6x11	Induction-hardened	3700	150	50	11	7	5	P28...
35x16	Induction-hardened	3900	100	50	11	7	7.5	P35...
55x25	Induction-hardened	3950	150	25	18	11	11.5	P55...

Tab. 4

> **Tilting roller slides with 4 rollers Ø30 for V-shaped guide rails 28x11**

Use the roller slide eccentric pin to adjust the backlash along the plane between the guide rails.

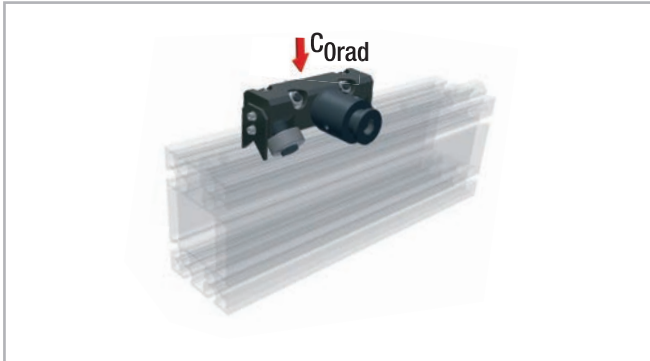

Important: remove the space washers to enable self-alignment of the roller slide Fig. 17

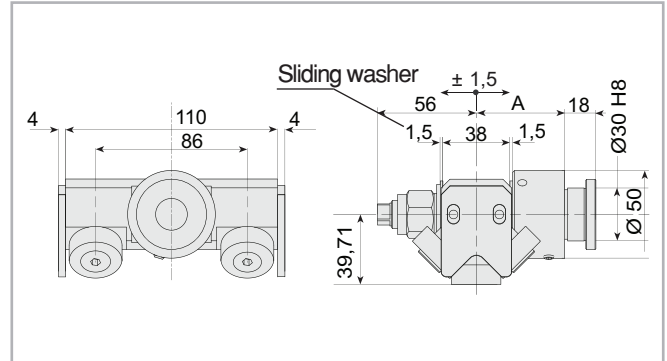

Fig. 18

	A [mm]	Load capacity C <sub>Orad</sub> [N]	Weight [Kg]	Code
Roller slide with concentric pin	75	3818	1.8	204.0052
Roller slide with eccentric pin (±1 mm)	75	3818	1.8	204.0053
Roller slide with concentric pin	50	3818	1.4	204.0054
Roller slide with eccentric pin (±1 mm)	50	3818	1.4	204.0055

Tab. 5

Spare parts	A [mm]	Code
Complete body with rollers		204.0050
Concentric pin	75	236.0010
Eccentric pin (±1 mm)	75	236.0011
Concentric pin	50	236.0014
Eccentric pin (±1 mm)	50	236.0015

Tab. 6

> **Tilting roller slides with 4 rollers Ø40 for V-shaped guide rails 35x16**

Use the roller slide eccentric pin to adjust the backlash along the plane between the guide rails.

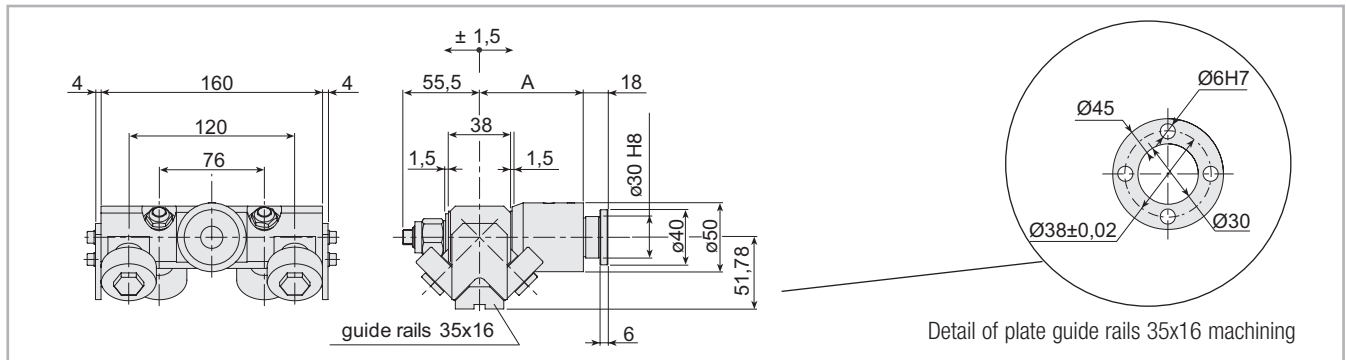

**Important:** remove the spacer washers to enable self-alignment of the roller slide

Fig. 19

	A [mm]	Load capacity C <sub>0rad</sub> [N]	Weight [Kg]	Code
Slide with eccentric pin (±1 mm)	75	7071	2.2	204.0016
Slide with eccentric pin (±1 mm)	50	7071	1.8	204.0033

Tab. 7

Spare parts	A [mm]	Code
Complete body with rollers		204.0013
Eccentric pin (±1 mm)	75	236.0011
Eccentric pin (±1 mm)	75	236.0015

Tab. 8

All pins are eccentric, but are made concentric by inserting the pin in the specific hole on the plate, in order to determine the required preload.



> **Type G roller slides (roller Ø52) and H type (roller Ø62) for V-shaped guide rails 55x25**

Tilting 4-roller slides Suitable for assembly pins: Type 9

Use the roller slide eccentric pin to adjust the backlash along the plane between the guide rails.

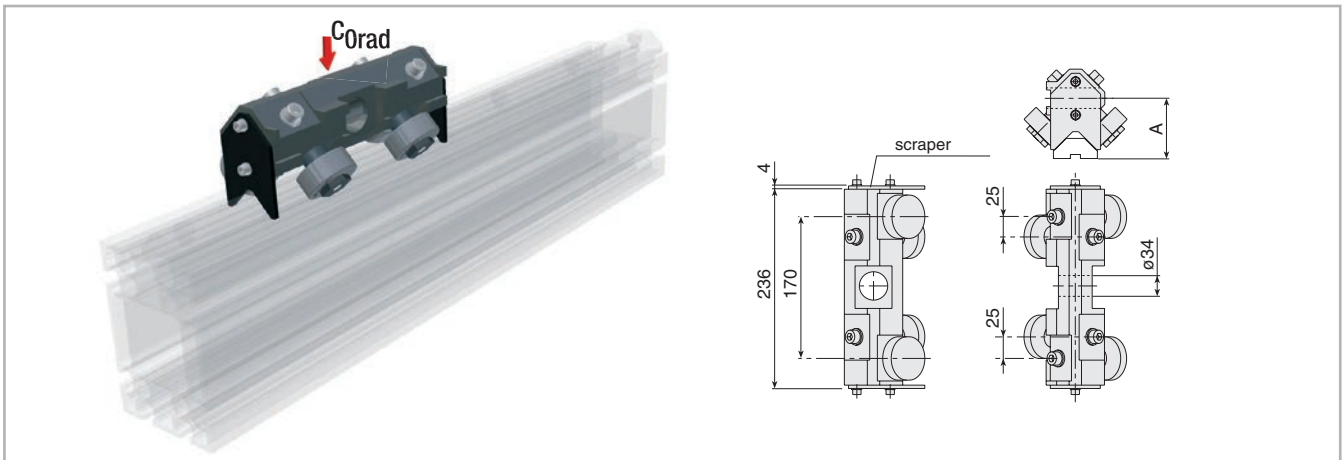

Fig. 20

Ø Rollers	A
Rollers Ø52	71.75
Rollers Ø62	78.85

Tab. 9

Technical characteristics	Ø52	Ø62
Load capacity [N]	12021	14991
N° roller	4	4
Weight [Kg]	3.2	3.8
Spare parts code	204.1520	204.1521

Tab. 10

**> I-type roller slides (roller Ø52) and L-type (roller Ø62) for V-shaped guide rails V 55x25**

Tilting 6-roller slides Suitable for assembly pins: Type 9

Use the roller slide eccentric pin to adjust the backlash along the plane between the guide rails.

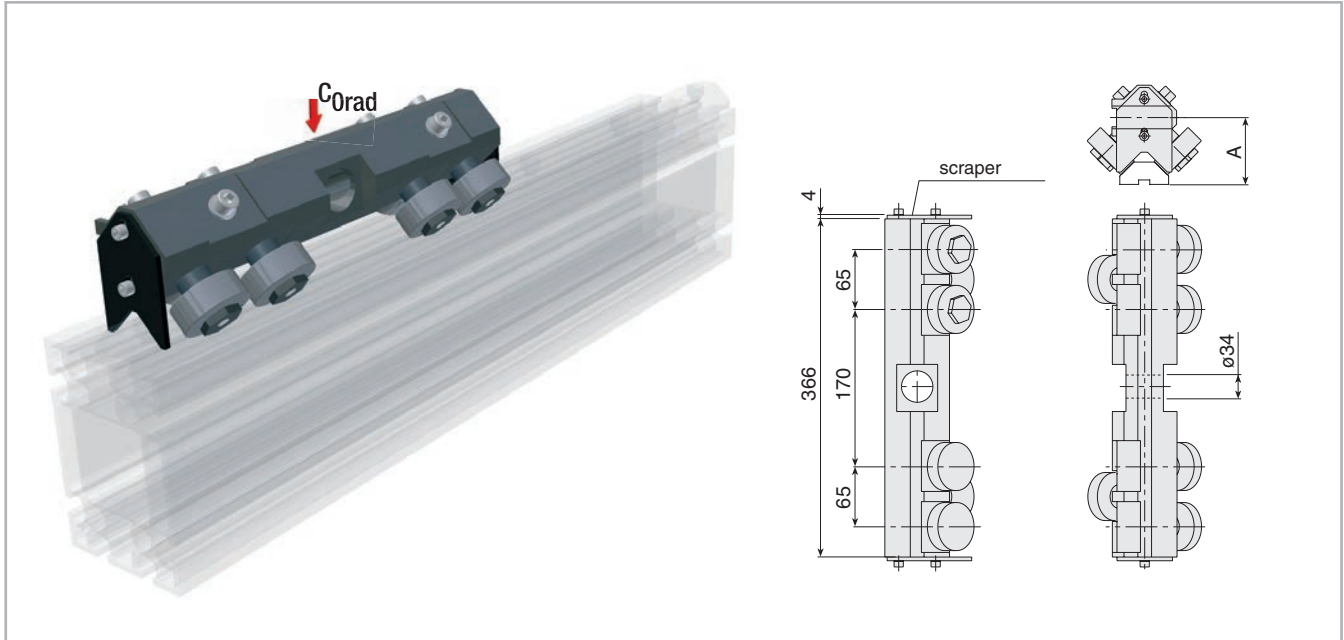

Fig. 21

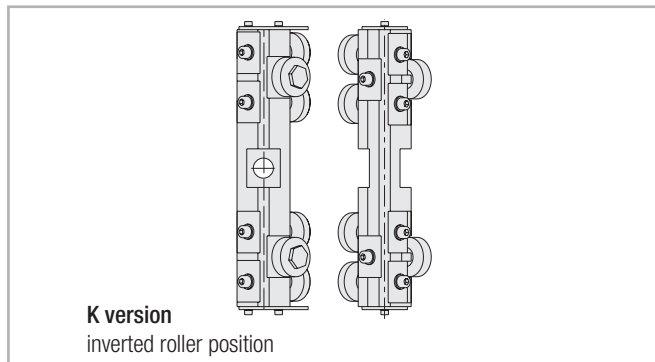

Fig. 22

Ø Roller	A
Roller Ø52	71.75
Roller Ø62	78.85

Tab. 11

Technical characteristics	Ø52	Ø62
Load capacity [N]	12021	14991
N° rollers	6	6
Weight [Kg]	4.9	5.9
Spare parts code	204.1522	204.1523

Tab. 12

# Accessories ✓

## > V-shaped rollers (Guide Rails 28.6 x 11) anti-oxidized version

Shaped rollers with radial bearings with 2RS sealing (medium version).

\* **IMPORTANT:** upon request, spacers can be supplied to increase the centre-distance between the guide rail and the roller supporting surface. In addition to the roller code, please indicate the required centre-distance (L). e.g. 205.0013.L



Fig. 23

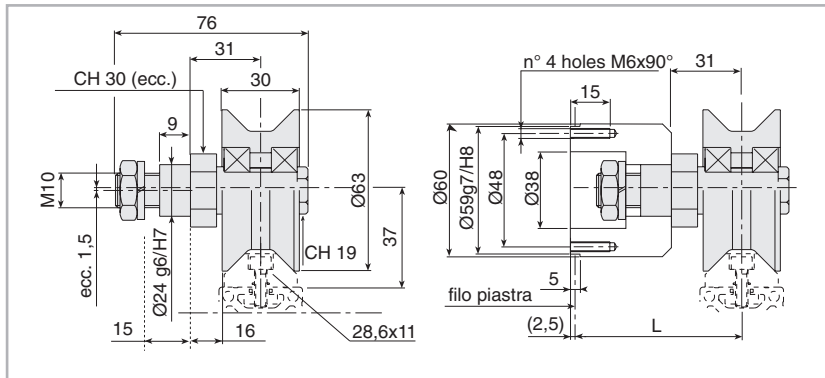

Fig. 24

Type	Bearing	C	C0w	PR [N]	PA [N]	Speed [m/s]	Weight [Kg]	Code
Conc.	radial bearing	9500	4540	1400	600	2.5	0.8	205.0013
Exc.	radial bearing	9500	4540	1400	600	2.5	0.8	205.0014

Tab. 13

## > V-shaped rollers [rails 35 x 16]

Shaped rollers with two rows of angular contact ball bearings. With bilateral sliding sealing rings. Accuracy class P6.

They support loads along the axis of the pin provided  $P_a \text{ eff} < 0.4 P_r \text{ eff}$ .

\* **IMPORTANT:** upon request, spacers can be supplied to increase the centre-distance between the guide rail and the roller supporting surface. In addition to the roller code, please indicate the required centre-distance (L). e.g. 205.0011.L



Fig. 25

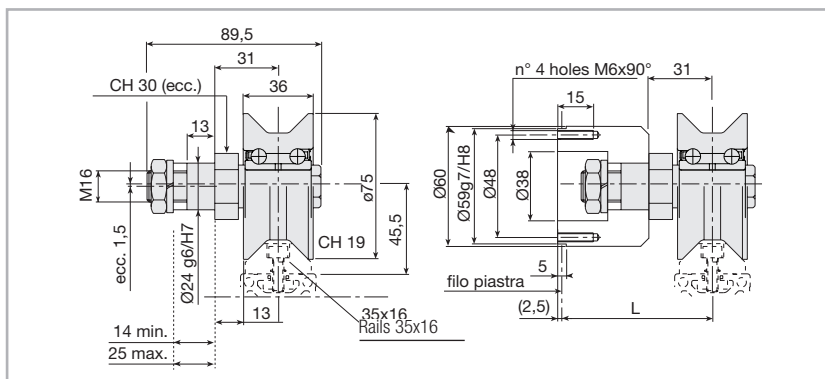

Fig. 26

Type	Bearing	C	C0w	PR [N]	PA [N]	Speed [m/s]	Weight [Kg]	Code
Conc.	angular contact	21000	13900	4500	1800	2.5	1	205.0011
Exc.	angular contact	21000	13900	4500	1800	2.5	1	205.0012

Tab. 14

> Spare roller with pin

Make sure that all the components are locked in place with the appropriate screws. The recommended tightening torque for pin locking screws and nuts is 50 Nm.



Fig. 27

Max. load factors for induction-hardened guides

Roller	Cw [N]	COw [N]	Fr amm. [N]	V max.
Ø30	5100	3100	1350	7 m/s
Ø40	10000	7000	2500	7 m/s
Ø52	16700	10700	4250	6 m/s
Ø62	21500	14500	5300	5 m/s

Tab. 15

Spare roller with pin	Weight [Kg]	Code
Ø30 Concentric	0.02	205.0465
Ø40 Concentric	0.22	205.0464
Ø40 Eccentric (± 0.75 mm)	0.25	205.0463
Ø52 Concentric	0.4	205.0163
Ø62 Concentric	0.55	205.0165

Tab. 16

> **Assembly Pins**

Material: burnished steel (Rs=800 N/mm<sup>2</sup>). Special variants upon request. 8-9 are complete with self-lubricating bushings to make roller slide self-adjustments easier.  
 AISI 303 stainless steel versions are available upon request. Types 0-7-

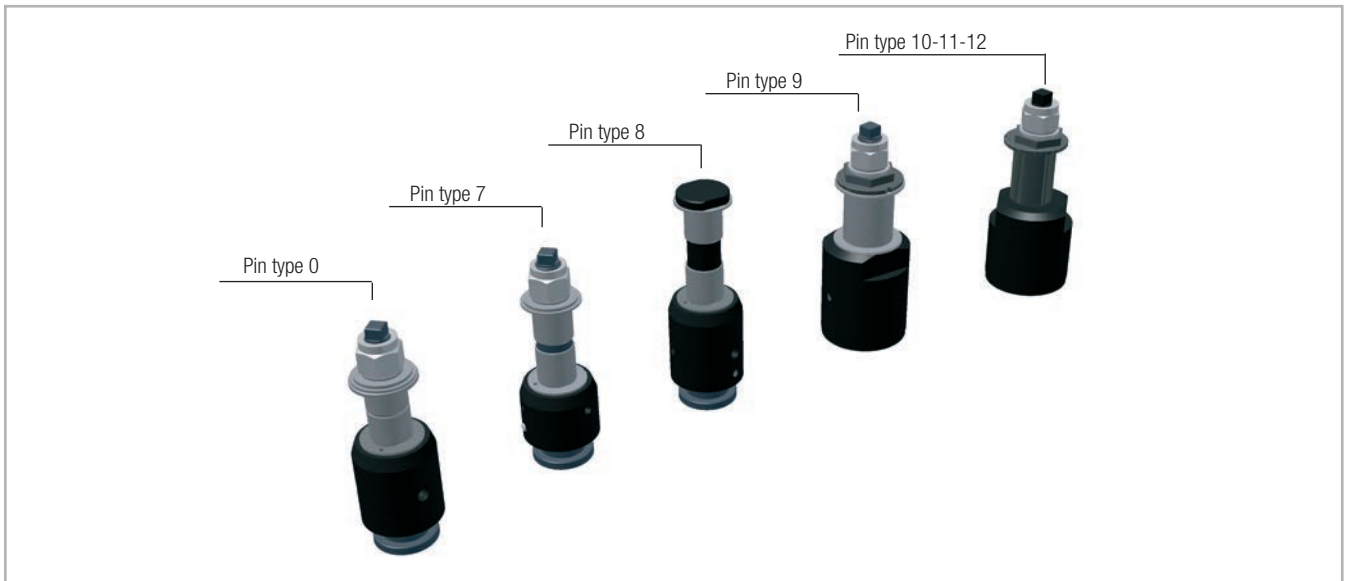

Fig. 28

> **Type 0 assembly pins suitable for roller slide Ø30 and Ø40**

\* **Important:** machine the pin clamping plate as shown in Fig. A

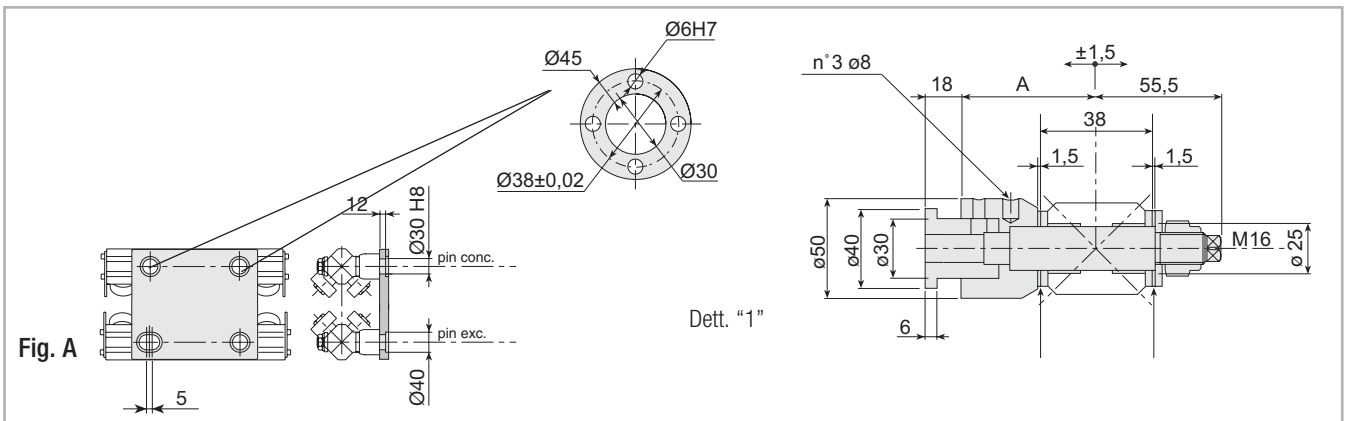

Fig. 29



Fig. 30

**Important:** remove the spacer washers to enable self-alignment of the roller slide

Technical characteristics	A [mm]	
Weight [Kg]		1.1 approx.
Eccentric code (±0.75 mm)	75	236.0011
Eccentric code (±0.75 mm)	50	236.0015

Tab. 17

> Type 7 assembly pins suitable for roller slide E-F

\* Important: machine the pin clamping plate as shown in Fig. A

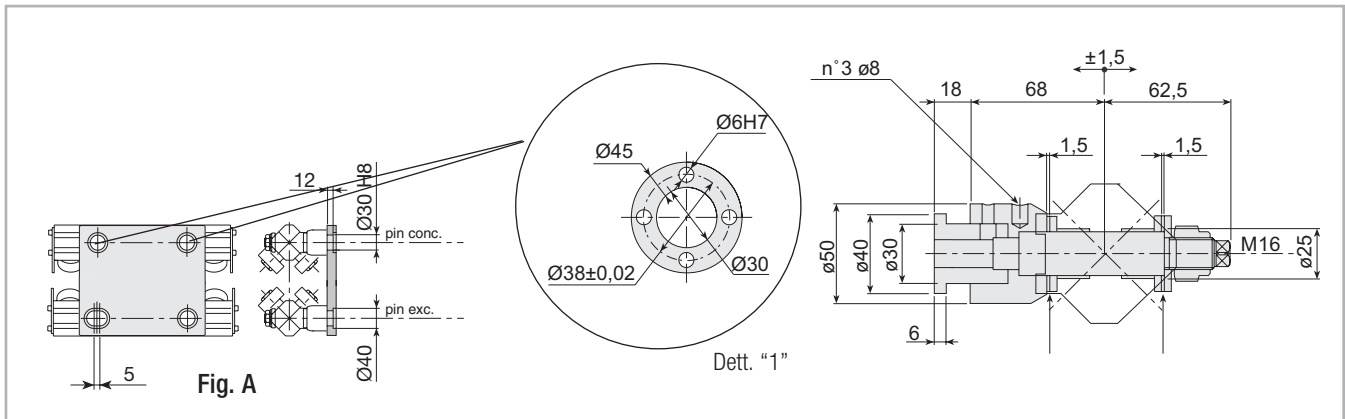

Fig. 31



Fig. 32

Important: remove the spacer washers to enable self-alignment of the roller slide

Technical characteristics	
Weight [Kg]	1.1 approx.
Eccentric code (± 1 mm)	236.1689

Tab. 18

> Assembly pins type 8 suitable for carriage E-F

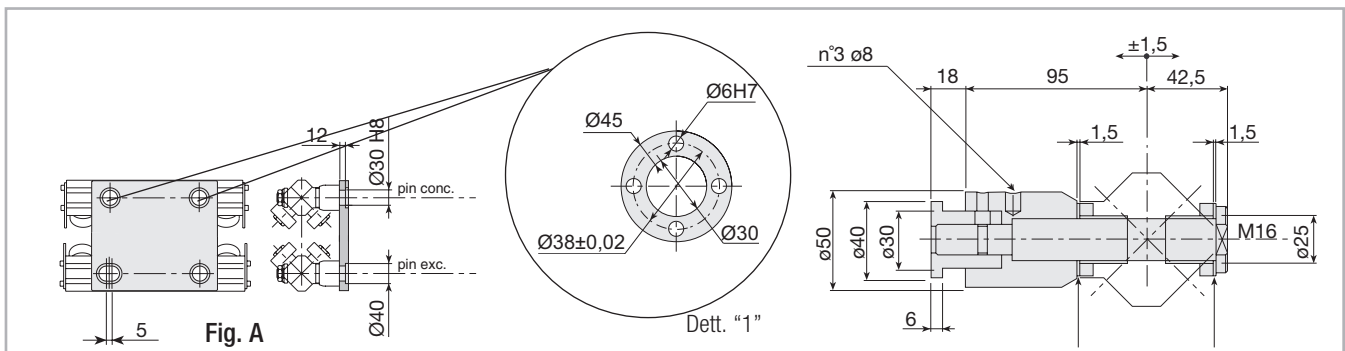

Fig. 33



Fig. 34

Important: remove the spacer washers to enable self-alignment of the roller slide

Technical characteristics	
Weight [Kg]	1.8 approx.
Eccentric code (±1 mm)	236.1691

Tab. 19

> Type 9 assembly pins suitable for tilting roller slides G-H / I-L



Fig. 35

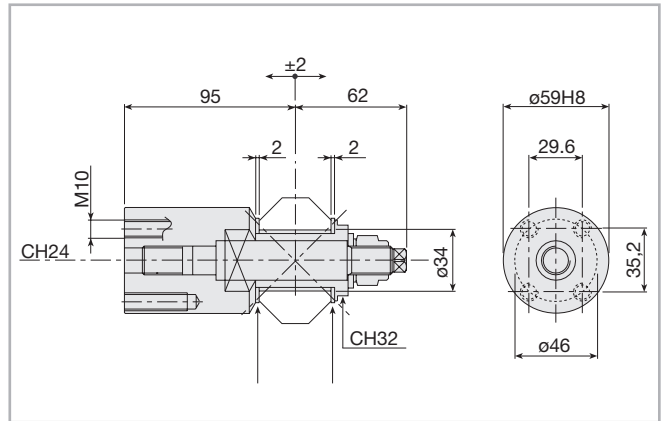

Fig. 36

**Important:** remove the spacer washers to enable self-alignment of the roller slide

Technical characteristics	
Weight [Kg]	2 approx.
Concentric code	236.2076
Eccentric code (± 1.5 mm)	236.2079

Tab. 20

> V-shaped guide rail assembly inserts

Material: C40 galvanized steel.

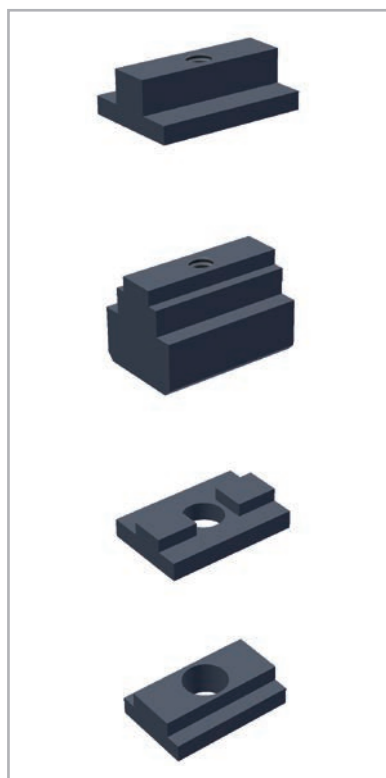

Fig. 37

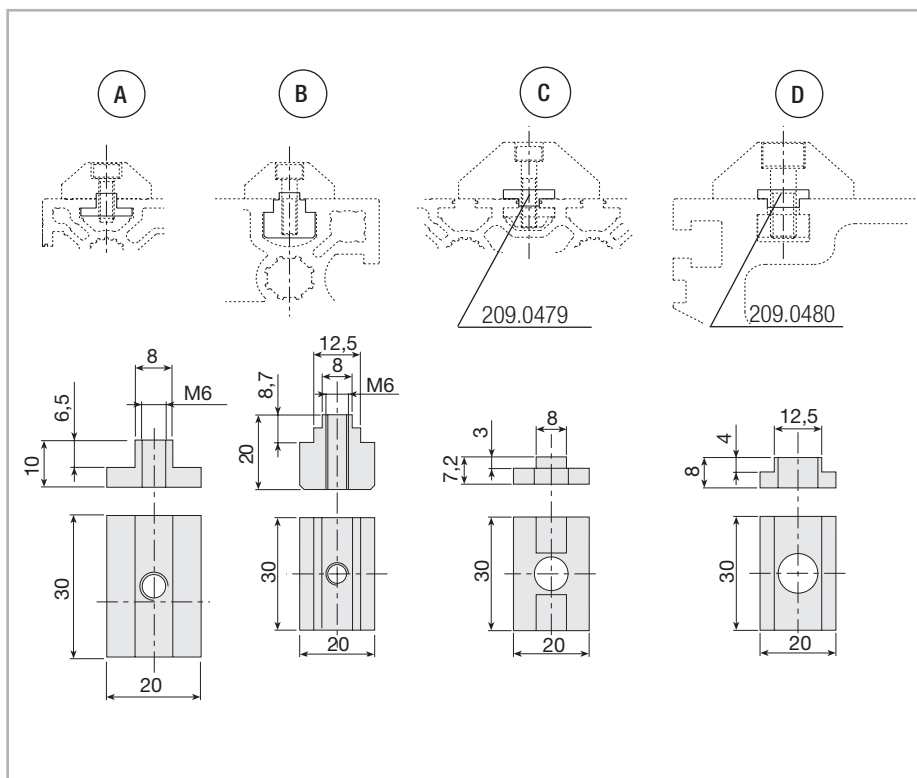

Fig. 38

Guide rails	Slot side	Screw	Code
A 35x16/28.6x11	8	M6x20	209.0298
B 35x16	12.5	M6x25	209.1855
C 55x25	8	M8x30	209.0479
D 55x25	12.5	M10x30	209.0480

Tab. 21



# Technical instructions

## > Rollers and V-shaped guide rails 28.6x11 and 35x16

Material: Hardened and burnished C45 steel covering; burnished steel pins and bolts. Rollers with shaped plastic cover are available upon request.  
 Rollers with longer centre-distance L can be supplied.

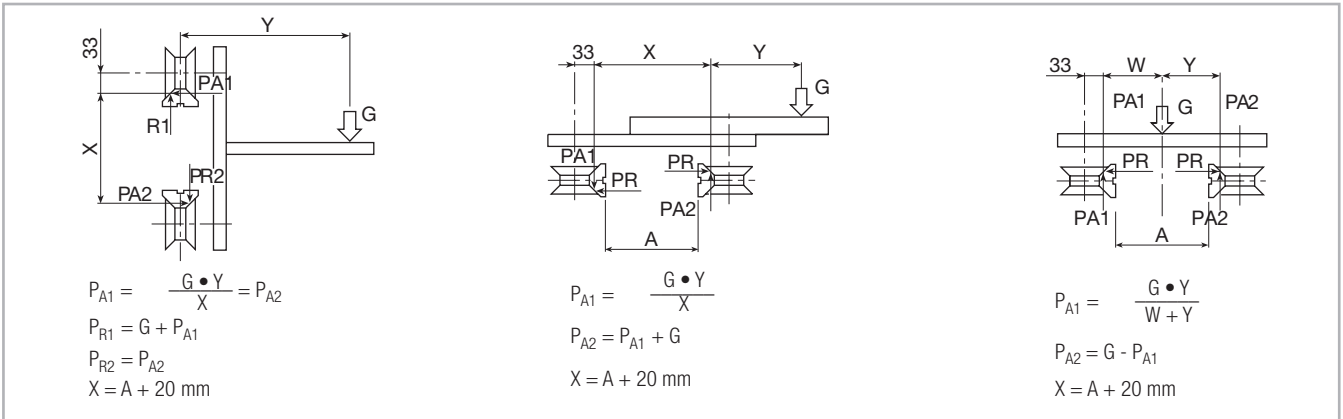
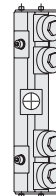
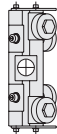
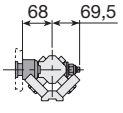
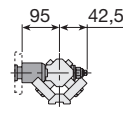
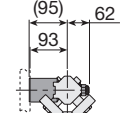
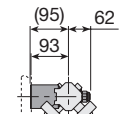
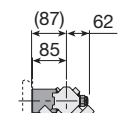
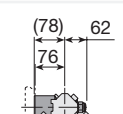

Fig. 39

Ordering key 

> Identification codes for roller slides and pins



	PIN	Roller sl.	G (Ø 52)	H (Ø 62)	I (Ø 52)	L (Ø 62)
	7	conc	-	-	-	-
		exc.	-	-	-	-
	8	conc				
		exc.				
	9	conc	204.2092	204.2093	204.2094	204.2095
		exc.	204.2102	204.2103	204.2104	204.2105
	10	conc	-	-	-	-
		exc.	-	-	-	-
	11	conc	-	-	-	-
		exc.	-	-	-	-
	12	conc	-	-	-	-
		exc.	-	-	-	-

Tab. 22

> Identification codes for Prismatic Rail guide

P	28	J	1100	F	XX	
	35				X = Single slanting cut	
	55				XX w= Double slanting cut	
					Drilled	
			Length			
		J = jointed rails (only when required)				
	Size					
Linear guides series Prismatic Rail						

Ordering example: P55-2750FX, P55-2600FXX, P55-J5200FC01

Notes on ordering: the rail length codes are always 4 digits; use zeroes as a prefix when lengths are shorter.

In case of jointed rails it is necessary to send the segmentation order.

> Assembly of standard carriages / K version carriages

**IMPORTANT:** for applications with high projecting loads, the rollers of the slides must be adjusted so that the load is supported by the maximum possible number of rollers. If this means arranging the rollers symmetrically with respect to the standard roller slide version, please add the letter K at the end of the code when filling in the order form. However, the roller assembly can also be inverted at a later date, by disassembling the pins and rollers and then reassembling them in the opposite way.

Example:

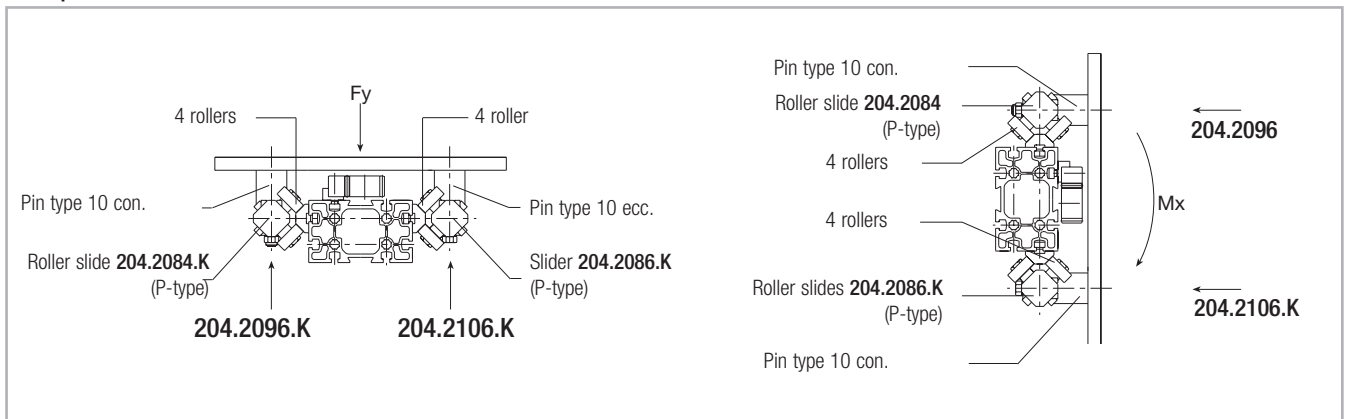

Fig. 40

P  
R